



**THE DATASHEET OF
MC100EP16VTDTG**



MC100EP16VT

3.3V / 5V ECL Differential Receiver/Driver with Variable Output Swing and Internal Input Termination

The MC100EP16VT is a differential receiver functionally equivalent to the 100EP16 with input pins controlling the amplitude of the outputs (pin 1) and providing an internal termination network (pin 4).

The V_{CTRL} input pin controls the output amplitude of the EP16VT and is referenced to V_{CC} . (See Figure 4.) The operational range of the V_{CTRL} input is from $\leq V_{BB}$ (a supply at $V_{CC}-1.42$ V, maximum output amplitude) to V_{CC} (minimum output amplitude). V_{BB} is an externally supplied voltage equal to $V_{CC}-1.42$ V (See Figures 2 and 3). A variable resistor between V_{CC} and V_{BB} , with the wiper driving V_{CTRL} , can control the output amplitude. Typical application circuits and a V_{CTRL} Voltage vs. Output Amplitude graph are described in this data sheet. When left open, the V_{CTRL} pin will be internally pulled down to V_{EE} and operate as a standard EP16, with 100% output amplitude.

The V_{TT} input pin offers an internal termination network for a 50 ohm line impedance environment, shown in Figure 1. For further reference, see Application Note AND8020, Termination of ECL Logic Devices. Input considerations are required for D and \bar{D} under no signal conditions to prevent instability.

Special considerations are required for differential inputs under No Signal conditions to prevent instability.

- 220 ps Propagation Delay
- Maximum Frequency > 4 GHz Typical (See Graph)
- The 100 Series Contains Temperature Compensation
- PECL Mode Operating Range: $V_{CC} = 3.0$ V to 5.5 V with $V_{EE} = 0$ V
- NECL Mode Operating Range: $V_{CC} = 0$ V with $V_{EE} = -3.0$ V to -5.5 V
- Open Input Default State
- 50 Ω Internal Termination Resistor



ON Semiconductor™

<http://onsemi.com>

MARKING DIAGRAMS*

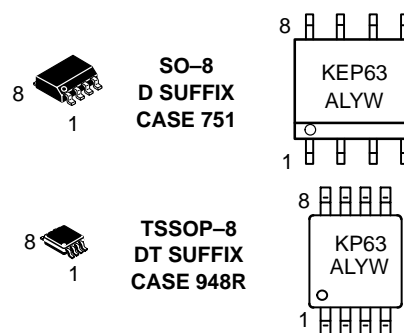

K = MC100
 A = Assembly Location
 L = Wafer Lot
 Y = Year
 W = Work Week

*For additional information, see Application Note AND8002/D

ORDERING INFORMATION

Device	Package	Shipping
MC100EP16VTD	SO-8	98 Units/Rail
MC100EP16VTDR2	SO-8	2500 Tape & Reel
MC100EP16VTDTD	TSSOP-8	100 Units/Rail
MC100EP16VTDTR2	TSSOP-8	2500 Tape & Reel

MC100EP16VT

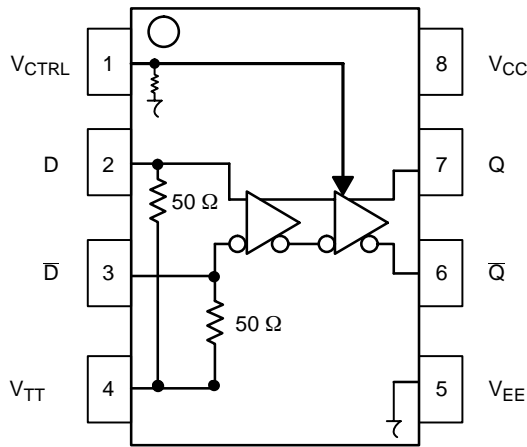

PIN DESCRIPTION

PIN	FUNCTION
D, \bar{D}	ECL Data Inputs
Q, \bar{Q}	ECL Data Outputs
V _{CTRL} *	Output Swing Control
V _{TT}	Termination Supply
V _{CC}	Positive Supply
V _{EE}	Negative Supply

* Pin will default LOW when left open.

Figure 1. 8-Lead Pinout (Top View) and Logic Diagram

ATTRIBUTES

Characteristics	Value
Internal Input Pulldown Resistor	75 k Ω
Internal Input Pullup Resistor	N/A
ESD Protection	Human Body Model Machine Model Charged Device Model
	> 4 kV > 200 V > 2 kV
Moisture Sensitivity, Indefinite Time Out of Drypack (Note 1.)	Level 1
Flammability Rating Oxygen Index	UL-94 code V-0 A 1/8" 28 to 34
Transistor Count	140 Devices
Meets or exceeds JEDEC Spec EIA/JESD78 IC Latchup Test	

1. For additional information, see Application Note AND8003/D.

MAXIMUM RATINGS (Note 2.)

Symbol	Parameter	Condition 1	Condition 2	Rating	Units
V _{CC}	PECL Mode Power Supply	V _{EE} = 0 V		6	V
V _{EE}	NECL Mode Power Supply	V _{CC} = 0 V		-6	V
V _I	PECL Mode Input Voltage NECL Mode Input Voltage	V _{EE} = 0 V V _{CC} = 0 V	V _I \leq V _{CC} V _I \geq V _{EE}	6 -6	V V
I _{out}	Output Current	Continuous Surge		50 100	mA mA
T _A	Operating Temperature Range			-40 to +85	$^{\circ}$ C
T _{stg}	Storage Temperature Range			-65 to +150	$^{\circ}$ C
θ_{JA}	Thermal Resistance (Junction to Ambient)	0 LFPM 500 LFPM	8 SOIC 8 SOIC	190 130	$^{\circ}$ C/W $^{\circ}$ C/W
θ_{JC}	Thermal Resistance (Junction to Case)	std bd	8 SOIC	41 to 44	$^{\circ}$ C/W
θ_{JA}	Thermal Resistance (Junction to Ambient)	0 LFPM 500 LFPM	8 TSSOP 8 TSSOP	185 140	$^{\circ}$ C/W $^{\circ}$ C/W
θ_{JC}	Thermal Resistance (Junction to Case)	std bd	8 TSSOP	41 to 44 \pm 5%	$^{\circ}$ C/W
T _{sol}	Wave Solder	<2 to 3 sec @ 248 $^{\circ}$ C		265	$^{\circ}$ C

2. Maximum Ratings are those values beyond which device damage may occur.

MC100EP16VT

DC CHARACTERISTICS, PECL $V_{CC} = 3.3\text{ V}$, $V_{EE} = 0\text{ V}$ (Note 3.)

Symbol	Characteristic	-40°C			25°C			85°C			Unit
		Min	Typ	Max	Min	Typ	Max	Min	Typ	Max	
I_{EE}	Power Supply Current	30	36	42	31	38	44	32	40	48	mA
V_{OH}	Output HIGH Voltage (Max Swing) (Note 4.) $V_{CC} \geq V_{CTRL} \geq V_{EE}$	2155		2405	2155		2405	2155		2405	mV
V_{OL}	Output LOW Voltage (Max Swing) (Note 4.) $V_{CTRL} \leq V_{BB}$	1355	1490	1605	1355	1520	1605	1355	1520	1605	mV
	$V_{CC} \geq V_{CTRL} > V_{BB}$		See Fig.2			See Fig.2		See Fig.2			
	$V_{CTRL} = V_{CC}$ (Min Swing)	2105	2230	2355	2095	2220	2345	2065	2190	2315	
V_{IH}	D, \bar{D} Input HIGH Voltage (Single Ended)	2075		2420	2075		2420	2075		2420	mV
V_{IL}	D, \bar{D} Input LOW Voltage (Single Ended)	1490		1675	1490		1675	1490		1675	mV
V_{CTRL}	Input Voltage (V_{CTRL})	V_{EE}		V_{CC}	V_{EE}		V_{CC}	V_{EE}		V_{CC}	mV
V_{IHCMR}	Input HIGH Voltage Common Mode Range (Differential) (Note 5.)	2.0		2.9	2.0		2.9	2.0		2.9	V
I_{IH}	Input HIGH Current (V_{TT} Open)			150			150			150	μA
I_{IL}	Input LOW Current (V_{TT} Open)	-150			-150			-150			μA

NOTE: EP circuits are designed to meet the DC specifications shown in the above table after thermal equilibrium has been established. The circuit is in a test socket or mounted on a printed circuit board and transverse airflow greater than 500 lfm is maintained.

3. Input and output parameters vary 1:1 with V_{CC} . V_{EE} can vary +0.3 V to -2.2 V.

4. All loading with 50 ohms to V_{CC} -2.0 volts. V_{OH} does not change with V_{CTRL} . V_{OL} changes with V_{CTRL} . V_{CTRL} is referenced to V_{CC} .

5. V_{IHCMR} min varies 1:1 with V_{EE} . V_{IHCMR} max varies 1:1 with V_{CC} . The V_{IHCMR} range is referenced to the most positive side of the differential input signal.

DC CHARACTERISTICS, PECL $V_{CC} = 5.0\text{ V}$, $V_{EE} = 0\text{ V}$ (Note 6.)

Symbol	Characteristic	-40°C			25°C			85°C			Unit
		Min	Typ	Max	Min	Typ	Max	Min	Typ	Max	
I_{EE}	Power Supply Current	30	36	42	31	38	44	32	40	48	mA
V_{OH}	Output HIGH Voltage (Note 7.) $V_{CC} > V_{CTRL} > V_{EE}$	3855	3980	4105	3855	3980	4105	3855	3980	4105	mV
V_{OL}	Output LOW Voltage (Max Swing) (Note 7.) $V_{CTRL} \leq V_{BB}$	3055	3190	3305	3055	3220	3305	3055	3220	3305	mV
	$V_{CC} \geq V_{CTRL} > V_{BB}$		See Fig.2			See Fig.2		See Fig.2			
	$V_{CTRL} = V_{CC}$ (Min Swing)	3805	3930	4055	3795	3920	4045	3765	3890	4015	
V_{IH}	D, \bar{D} Input HIGH Voltage (Single Ended)	3775		4120	3775		4120	3775		4120	mV
V_{IL}	D, \bar{D} Input LOW Voltage (Single Ended)	3190		3375	3190		3375	3190		3375	mV
V_{CTRL}	Input Voltage (V_{CTRL})	V_{EE}		V_{CC}	V_{EE}		V_{CC}	V_{EE}		V_{CC}	mV
V_{IHCMR}	Input HIGH Voltage Common Mode Range (Differential) (Note 8.)	2.0		4.6	2.0		4.6	2.0		4.6	V
I_{IH}	Input HIGH Current (V_{TT} Open)			150			150			150	μA
I_{IL}	Input LOW Current (V_{TT} Open)	-150			-150			-150			μA

NOTE: EP circuits are designed to meet the DC specifications shown in the above table after thermal equilibrium has been established. The circuit is in a test socket or mounted on a printed circuit board and transverse airflow greater than 500 lfm is maintained.

6. Input and output parameters vary 1:1 with V_{CC} . V_{EE} can vary +2.0 V to -0.5 V.

7. All loading with 50 ohms to V_{CC} -2.0 volts. V_{OH} does not change with V_{CTRL} . V_{OL} changes with V_{CTRL} . V_{CTRL} is referenced to V_{CC} .

8. V_{IHCMR} min varies 1:1 with V_{EE} . V_{IHCMR} max varies 1:1 with V_{CC} . The V_{IHCMR} range is referenced to the most positive side of the differential input signal.

MC100EP16VT

DC CHARACTERISTICS, NECL $V_{CC} = 0\text{ V}$; $V_{EE} = -5.5\text{ V}$ to -3.0 V (Note 9.)

Symbol	Characteristic	-40°C			25°C			85°C			Unit
		Min	Typ	Max	Min	Typ	Max	Min	Typ	Max	
I_{EE}	Power Supply Current	30	36	42	31	38	44	32	40	48	mA
V_{OH}	Output HIGH Voltage (Note 10.) $V_{CC} > V_{CTRL} > V_{EE}$	-1145	-1020	-895	-1145	-1020	-895	-1145	-1020	-895	mV
V_{OL}	Output LOW Voltage (Max Swing) (Note 10.) $V_{CTRL} \leq V_{BB}$	-1945	-1810	-1695	-1945	-1780	-1695	-1945	-1780	-1695	mV
	$V_{CC} \geq V_{CTRL} > V_{BB}$		See Fig.2			See Fig.2			See Fig.2		
	$V_{CTRL} = V_{CC}$ (Min Swing)	-1195	-1070	-945	-1205	-1080	-955	-1235	-1110	-985	
V_{IH}	D, \bar{D} Input HIGH Voltage (Single Ended)	-1225		-880	-1225		-880	-1225		-880	mV
V_{IL}	D, \bar{D} Input LOW Voltage (Single Ended)	-1810		-1625	-1810		-1625	-1810		-1625	mV
V_{CTRL}	Input Voltage (V_{CTRL})	V_{EE}		V_{CC}	V_{EE}		V_{CC}	V_{EE}		V_{CC}	mV
V_{IHCMR}	Input HIGH Voltage Common Mode Range (Differential) (Note 11.)	$V_{EE}+2.0$		-0.4	$V_{EE}+2.0$		-0.4	$V_{EE}+2.0$		-0.4	V
I_{IH}	Input HIGH Current (V_{TT} Open)			150			150			150	μA
I_{IL}	Input LOW Current (V_{TT} Open)	-150			-150			-150			μA

NOTE: EP circuits are designed to meet the DC specifications shown in the above table after thermal equilibrium has been established. The circuit is in a test socket or mounted on a printed circuit board and transverse airflow greater than 500 lfm is maintained.

9. Input and output parameters vary 1:1 with V_{CC} .

10. All loading with 50 ohms to $V_{CC}-2.0$ volts. V_{OH} does not change with V_{CTRL} . V_{OL} changes with V_{CTRL} . V_{CTRL} is referenced to V_{CC} .

11. V_{IHCMR} min varies 1:1 with V_{EE} , V_{IHCMR} max varies 1:1 with V_{CC} . The V_{IHCMR} range is referenced to the most positive side of the differential input signal.

AC CHARACTERISTICS $V_{CC} = 0\text{ V}$; $V_{EE} = -3.0\text{ V}$ to -5.5 V or $V_{CC} = 3.0\text{ V}$ to 5.5 V ; $V_{EE} = 0\text{ V}$ (Note 12.)

Symbol	Characteristic	-40°C			25°C			85°C			Unit
		Min	Typ	Max	Min	Typ	Max	Min	Typ	Max	
f_{max}	Maximum Toggle Frequency (See Figure 8. $F_{max}/JITTER$)		> 4			> 4			> 4		GHz
t_{PLH} , t_{PHL}	Propagation Delay to Output Differential Max Swing Min Swing	250 200	300 250	350 300	250 200	300 250	350 300	250 200	300 250	350 300	ps
t_{SKEW}	Duty Cycle Skew (Note 13.)		5.0	20		5.0	20		5.0	20	ps
t_{JITTER}	Cycle-to-Cycle Jitter (See Figure 8. $F_{max}/JITTER$)		0.2	< 1		0.2	< 1		0.2	< 1	ps
V_{PP}	Input Voltage Swing (Differential) (Note 14.)	150	800	1200	150	800	1200	150	800	1200	mV
t_r , t_f	Output Rise/Fall Times Max Swing Q Min Swing	70 30	120 80	170 130	80 20	130 70	180 120	100 20	150 70	200 120	ps

12. Measured using a 750 mV source, 50% duty cycle clock source. All loading with 50 ohms to $V_{CC}-2.0\text{ V}$.

13. Skew is measured between outputs under identical transitions. Duty cycle skew is defined only for differential operation when the delays are measured from the cross point of the inputs to the cross point of the outputs.

14. $V_{PP}(\text{min})$ is minimum input swing for which AC parameters are guaranteed.

MC100EP16VT

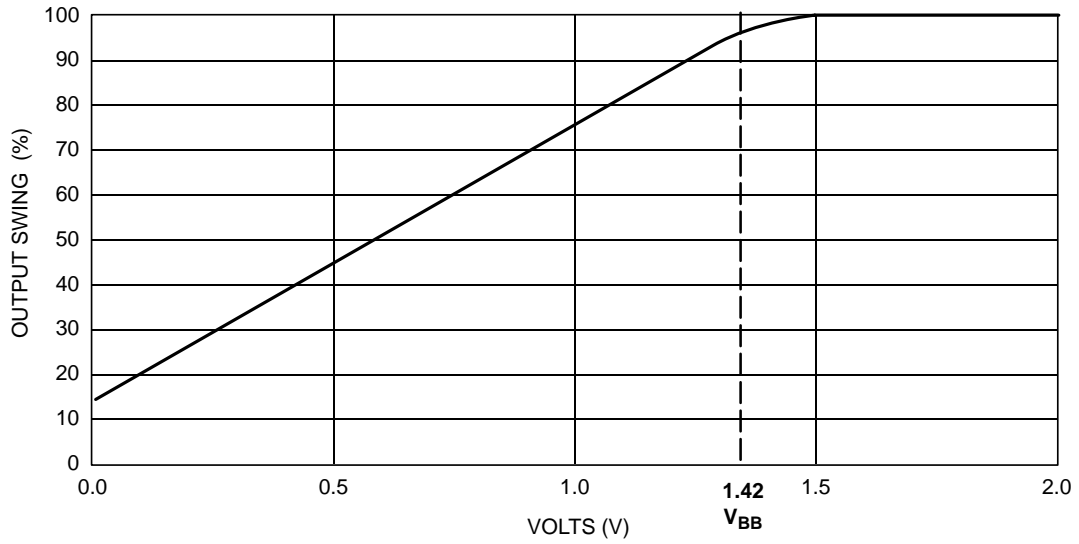

Figure 2. V_{CC} - V_{CTRL} (pin #1)

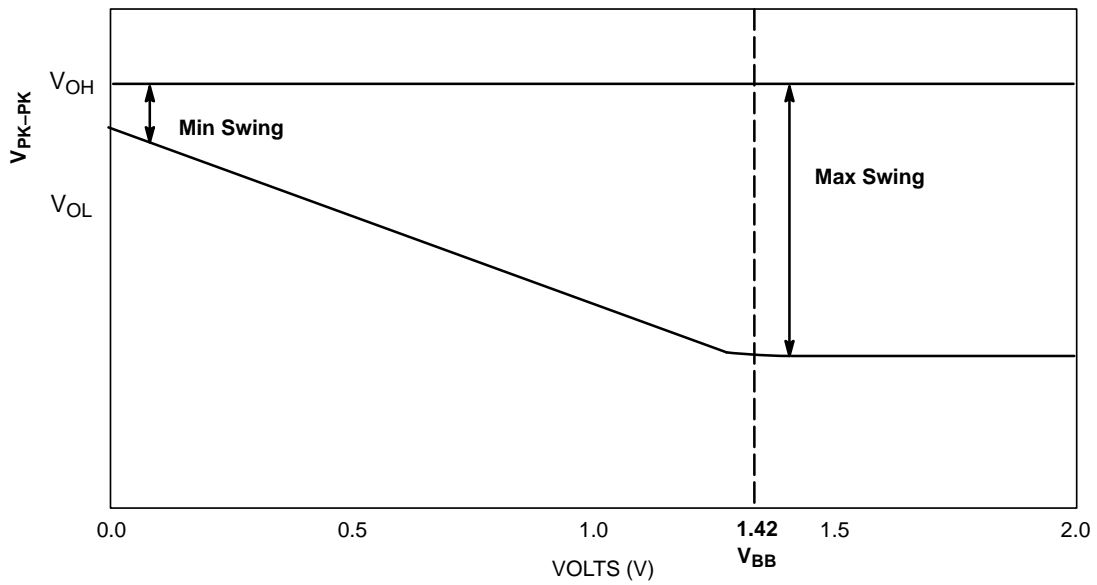

Figure 3. V_{CC} - V_{CTRL}

MC100EP16VT

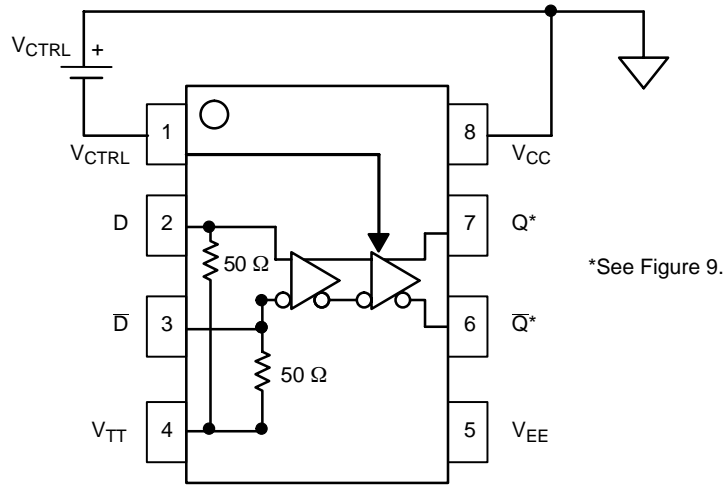

Figure 4. Voltage Source Implementation, V_{CTRL} Pin 1

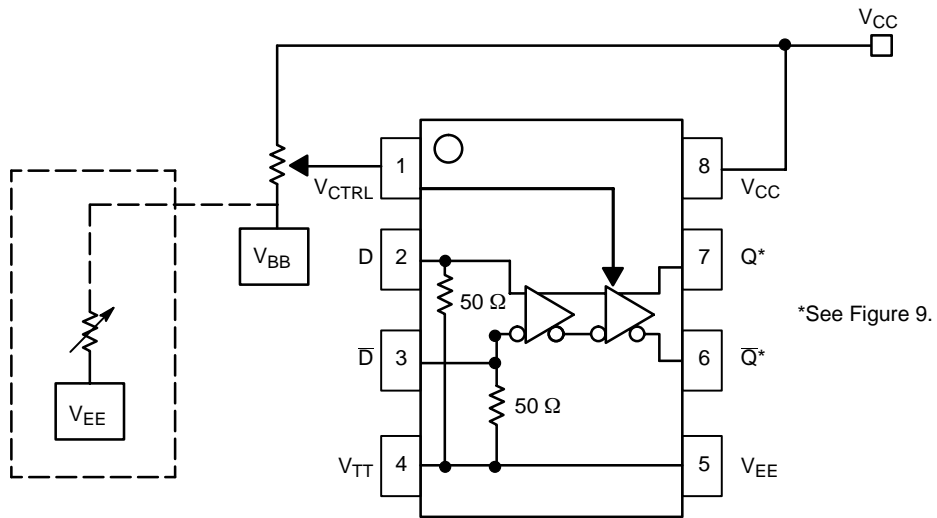

Figure 5. Alternative Implementations, V_{CTRL} Pin 1

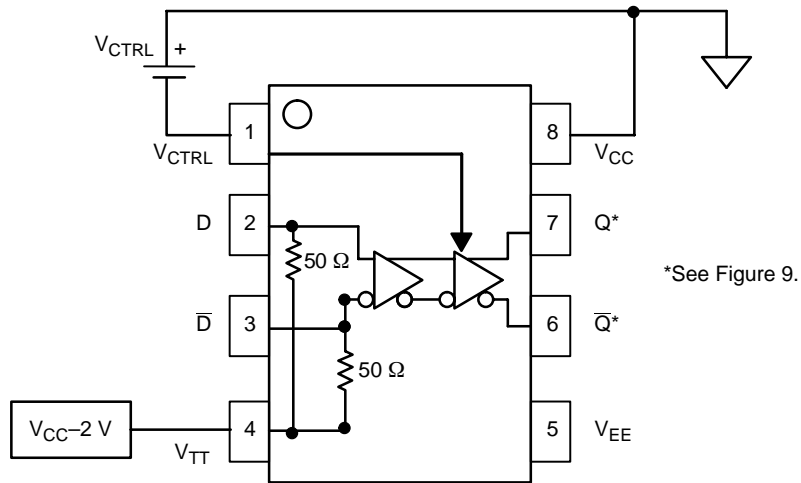

Figure 6. Standard Termination Method, V_{TT} Pin 4

MC100EP16VT

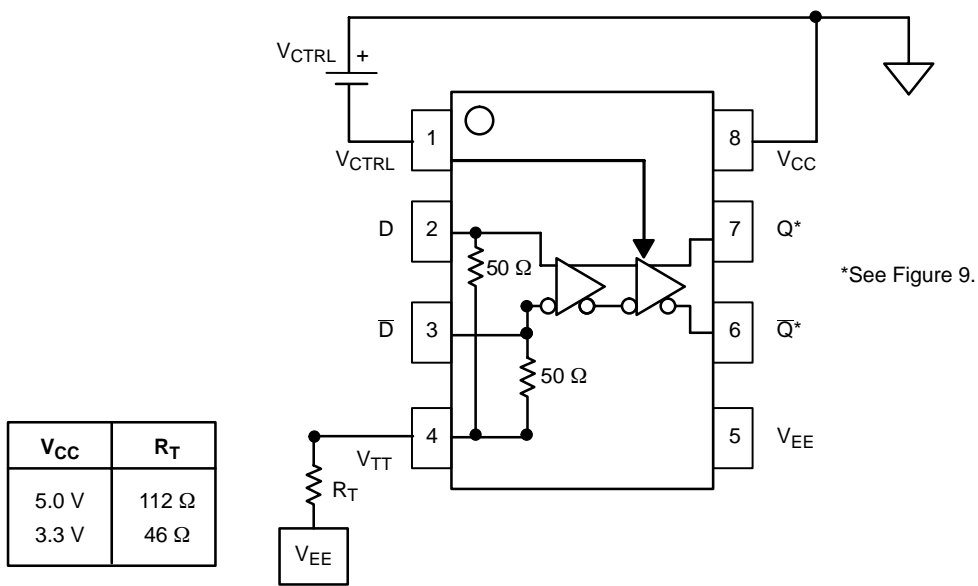

Figure 7. Alternate "Y" Termination Method, V_{TT} Pin 4

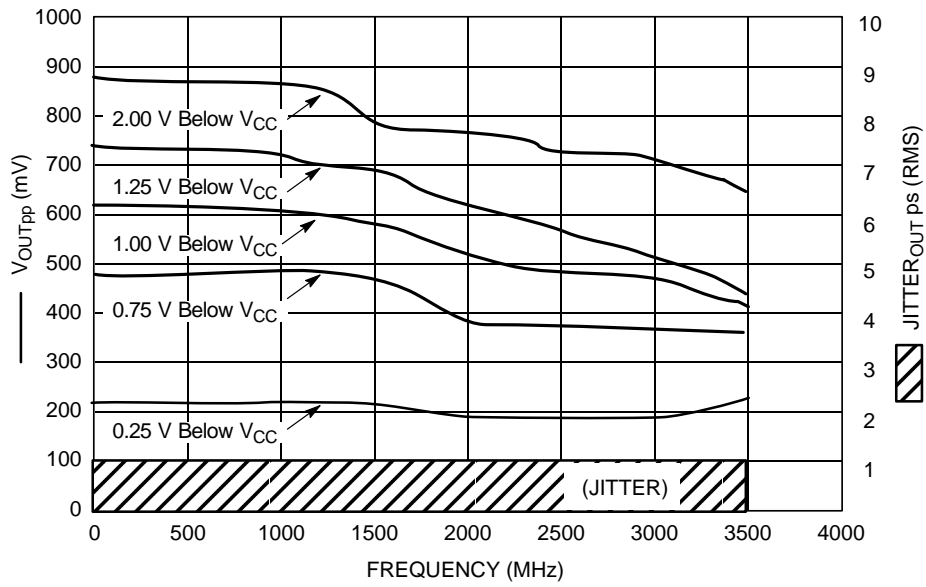
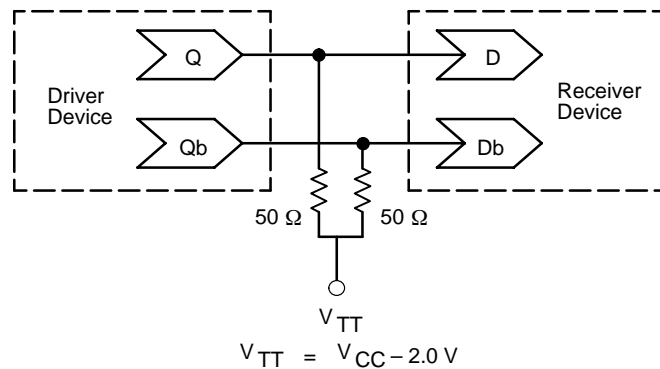

Figure 8. F_{max}/Jitter

MC100EP16VT



**Figure 9. Typical Termination for Output Driver and Device Evaluation
(See Application Note AND8020 – Termination of ECL Logic Devices.)**

Resource Reference of Application Notes

- AN1404** – ECLinPS Circuit Performance at Non-Standard V_{IH} Levels
- AN1405** – ECL Clock Distribution Techniques
- AN1406** – Designing with PECL (ECL at +5.0 V)
- AN1504** – Metastability and the ECLinPS Family
- AN1568** – Interfacing Between LVDS and ECL
- AN1650** – Using Wire-OR Ties in ECLinPS Designs
- AN1672** – The ECL Translator Guide
- AND8001** – Odd Number Counters Design
- AND8002** – Marking and Date Codes
- AND8009** – ECLinPS Plus Spice I/O Model Kit
- AND8020** – Termination of ECL Logic Devices

For an updated list of Application Notes, please see our website at <http://onsemi.com>.

MC100EP16VT

PACKAGE DIMENSIONS

SO-8 D SUFFIX PLASTIC SOIC PACKAGE CASE 751-07 ISSUE W

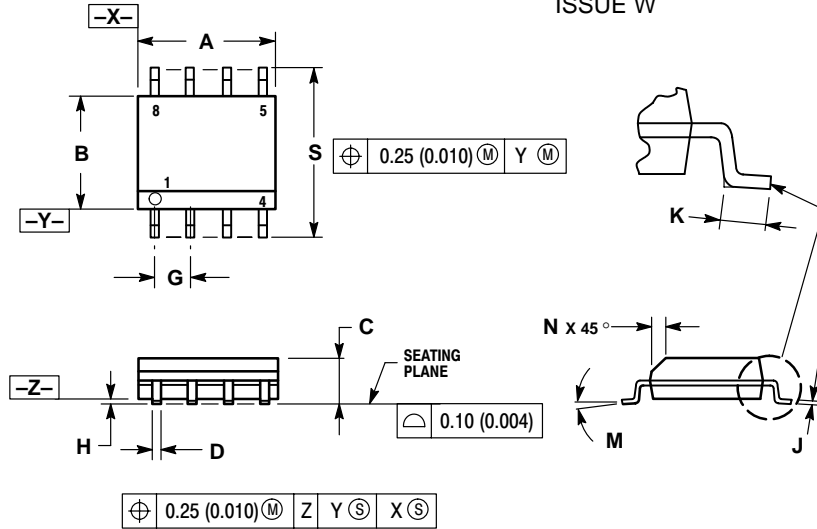

NOTES:

1. DIMENSIONING AND TOLERANCING PER ANSI Y14.5M, 1982.
2. CONTROLLING DIMENSION: MILLIMETER.
3. DIMENSION A AND B DO NOT INCLUDE MOLD PROTRUSION.
4. MAXIMUM MOLD PROTRUSION 0.15 (0.006) PER SIDE.
5. DIMENSION D DOES NOT INCLUDE DAMBAR PROTRUSION. ALLOWABLE DAMBAR PROTRUSION SHALL BE 0.127 (0.005) TOTAL IN EXCESS OF THE D DIMENSION AT MAXIMUM MATERIAL CONDITION.

DIM	MILLIMETERS		INCHES	
	MIN	MAX	MIN	MAX
A	4.80	5.00	0.189	0.197
B	3.80	4.00	0.150	0.157
C	1.35	1.75	0.053	0.069
D	0.33	0.51	0.013	0.020
G	1.27 BSC		0.050 BSC	
H	0.10	0.25	0.004	0.010
J	0.19	0.25	0.007	0.010
K	0.40	1.27	0.016	0.050
M	0°	8°	0°	8°
N	0.25	0.50	0.010	0.020
S	5.80	6.20	0.228	0.244

TSSOP-8 DT SUFFIX PLASTIC TSSOP PACKAGE CASE 948R-02 ISSUE A

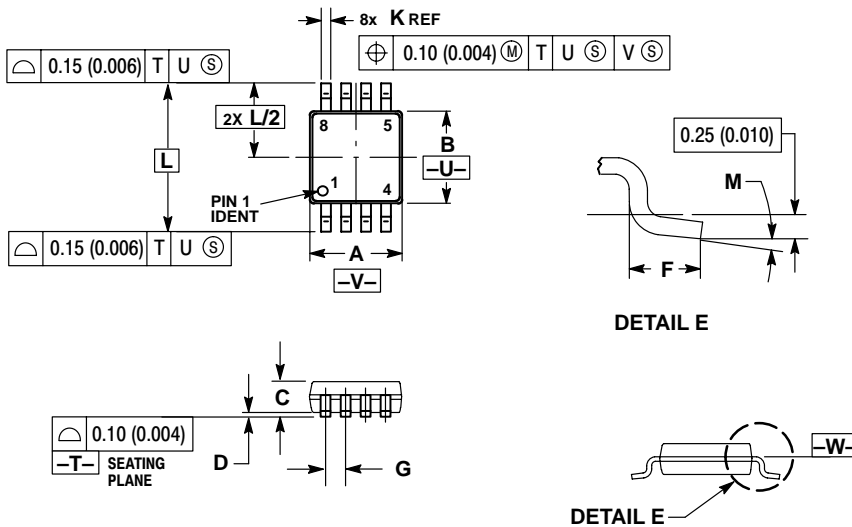

NOTES:

1. DIMENSIONING AND TOLERANCING PER ANSI Y14.5M, 1982.
2. CONTROLLING DIMENSION: MILLIMETER.
3. DIMENSION A DOES NOT INCLUDE MOLD FLASH, PROTRUSIONS OR GATE BURRS. MOLD FLASH OR GATE BURRS SHALL NOT EXCEED 0.15 (0.006) PER SIDE.
4. DIMENSION B DOES NOT INCLUDE INTERLEAD FLASH OR PROTRUSION. INTERLEAD FLASH OR PROTRUSION SHALL NOT EXCEED 0.25 (0.010) PER SIDE.
5. TERMINAL NUMBERS ARE SHOWN FOR REFERENCE ONLY.
6. DIMENSION A AND B ARE TO BE DETERMINED AT DATUM PLANE -W-.

DIM	MILLIMETERS		INCHES	
	MIN	MAX	MIN	MAX
A	2.90	3.10	0.114	0.122
B	2.90	3.10	0.114	0.122
C	0.80	1.10	0.031	0.043
D	0.05	0.15	0.002	0.006
F	0.40	0.70	0.016	0.028
G	0.65 BSC		0.026 BSC	
K	0.25	0.40	0.010	0.016
L	4.90 BSC		0.193 BSC	
M	0°	6°	0°	6°

Notes

Notes

MC100EP16VT

ON Semiconductor and  are trademarks of Semiconductor Components Industries, LLC (SCILLC). SCILLC reserves the right to make changes without further notice to any products herein. SCILLC makes no warranty, representation or guarantee regarding the suitability of its products for any particular purpose, nor does SCILLC assume any liability arising out of the application or use of any product or circuit, and specifically disclaims any and all liability, including without limitation special, consequential or incidental damages. "Typical" parameters which may be provided in SCILLC data sheets and/or specifications can and do vary in different applications and actual performance may vary over time. All operating parameters, including "Typicals" must be validated for each customer application by customer's technical experts. SCILLC does not convey any license under its patent rights nor the rights of others. SCILLC products are not designed, intended, or authorized for use as components in systems intended for surgical implant into the body, or other applications intended to support or sustain life, or for any other application in which the failure of the SCILLC product could create a situation where personal injury or death may occur. Should Buyer purchase or use SCILLC products for any such unintended or unauthorized application, Buyer shall indemnify and hold SCILLC and its officers, employees, subsidiaries, affiliates, and distributors harmless against all claims, costs, damages, and expenses, and reasonable attorney fees arising out of, directly or indirectly, any claim of personal injury or death associated with such unintended or unauthorized use, even if such claim alleges that SCILLC was negligent regarding the design or manufacture of the part. SCILLC is an Equal Opportunity/Affirmative Action Employer.

PUBLICATION ORDERING INFORMATION

NORTH AMERICA Literature Fulfillment:

Literature Distribution Center for ON Semiconductor
P.O. Box 5163, Denver, Colorado 80217 USA
Phone: 303-675-2175 or 800-344-3860 Toll Free USA/Canada
Fax: 303-675-2176 or 800-344-3867 Toll Free USA/Canada
Email: ONlit@hibbertco.com
Fax Response Line: 303-675-2167 or 800-344-3810 Toll Free USA/Canada

N. American Technical Support: 800-282-9855 Toll Free USA/Canada

EUROPE: LDC for ON Semiconductor – European Support

German Phone: (+1) 303-308-7140 (Mon-Fri 2:30pm to 7:00pm CET)
Email: ONlit-german@hibbertco.com
French Phone: (+1) 303-308-7141 (Mon-Fri 2:00pm to 7:00pm CET)
Email: ONlit-french@hibbertco.com
English Phone: (+1) 303-308-7142 (Mon-Fri 12:00pm to 5:00pm GMT)
Email: ONlit@hibbertco.com

EUROPEAN TOLL-FREE ACCESS*: 00-800-4422-3781

*Available from Germany, France, Italy, UK, Ireland

CENTRAL/SOUTH AMERICA:

Spanish Phone: 303-308-7143 (Mon-Fri 8:00am to 5:00pm MST)
Email: ONlit-spanish@hibbertco.com
Toll-Free from Mexico: Dial 01-800-288-2872 for Access –
then Dial 866-297-9322

ASIA/PACIFIC: LDC for ON Semiconductor – Asia Support

Phone: 303-675-2121 (Tue-Fri 9:00am to 1:00pm, Hong Kong Time)
Toll Free from Hong Kong & Singapore:
001-800-4422-3781

Email: ONlit-asia@hibbertco.com

JAPAN: ON Semiconductor, Japan Customer Focus Center

4-32-1 Nishi-Gotanda, Shinagawa-ku, Tokyo, Japan 141-0031
Phone: 81-3-5740-2700
Email: r14525@onsemi.com

ON Semiconductor Website: <http://onsemi.com>

For additional information, please contact your local Sales Representative.

Looking for pricing, stock, or lifecycle information?

Click below to explore more details on WIN SOURCE:

 [View MC100EP16VTDTG on WIN SOURCE](#)

 [ON Semiconductor](#) Information

Optimize Your Supply Chain with WIN SOURCE Solutions

-  Global Sourcing Solution
-  Obsolete Management
-  Cost Control Management
-  Shortage Management
-  Alternative Solution
-  Excess Inventory Management