



**THE DATASHEET OF  
BQ27421YZFR-G1A**



# bq27421-G1 System-Side Impedance Track™ Fuel Gauge With Integrated Sense Resistor

## 1 Features

- Single-Cell Li-Ion Battery Fuel Gauge
  - Resides on System Board
  - Supports Embedded or Removable Batteries
  - Powered Directly from Battery with Integrated LDO
  - Low-Value Integrated Sense Resistor (7 mΩ, Typical)
- Easy-to-Configure Fuel Gauging Based on Patented Impedance Track™ Technology
  - Reports Remaining Capacity and State-of-Charge (SOC) with Smoothing Filter
  - Automatically Adjusts for Battery Aging, Self-Discharge, Temperature, and Rate Changes
  - Battery State-of-Health (Aging) Estimation
- Microcontroller Peripheral Supports:
  - 400-kHz I<sup>2</sup>C Serial Interface
  - Configurable SOC Interrupt or Battery Low Digital Output Warning
  - Internal Temperature Sensor or Host-Reported Temperature

## 2 Applications

- Smartphones, Feature Phones, and Tablets
- Digital Still and Video Cameras
- Handheld Terminals
- MP3 or Multimedia Players

## 3 Description

The Texas Instruments bq27421-G1 fuel gauge is a minimally configured microcontroller peripheral that provides system-side fuel gauging for single-cell Li-Ion batteries. The device requires very little user configuration and system microcontroller firmware development.

The bq27421-G1 fuel gauge uses the patented Impedance Track™ algorithm for fuel gauging, and provides information such as remaining battery capacity (mAh), state-of-charge (%), and battery voltage (mV).

Battery fuel gauging with the bq27421-G1 fuel gauge requires connections only to PACK+ (P+) and PACK– (P–) for a removable battery pack or embedded battery circuit. The tiny 9-ball, 1.62 mm × 1.58 mm, 0.5-mm pitch NanoFree™ chip scale package (DSBGA) is ideal for space-constrained applications.

### Device Information<sup>(1)</sup>

PART NUMBER	PACKAGE	BODY SIZE (NOM)
bq27421-G1	YZF (9)	1.62 mm × 1.58 mm

(1) For all available packages, see the orderable addendum at the end of the data sheet.

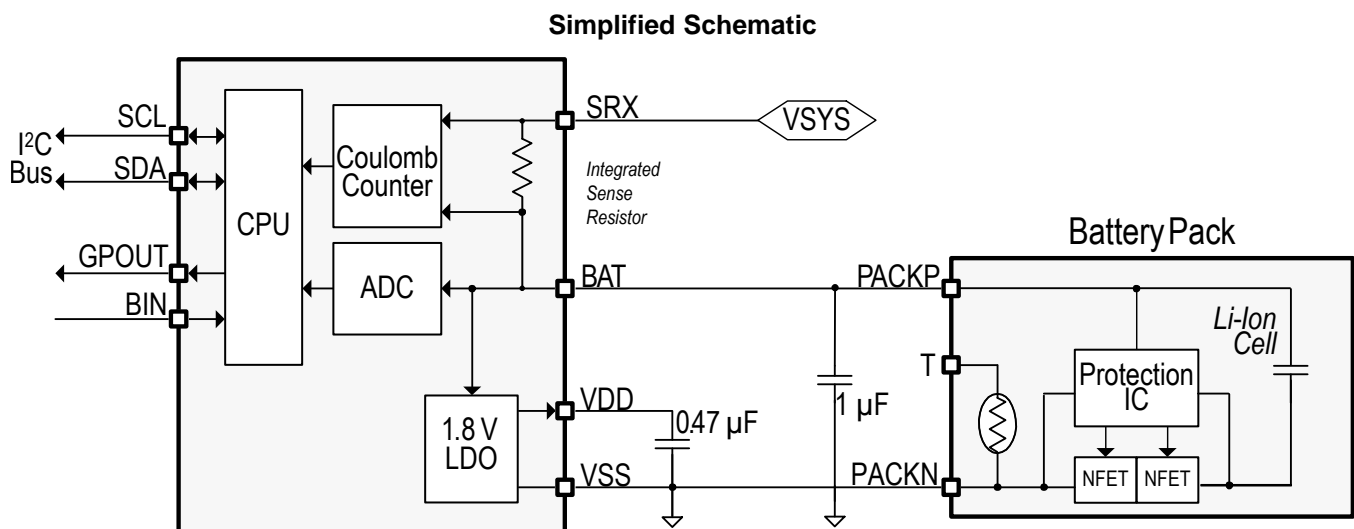

## Table of Contents

<b>1 Features</b> .....	<b>1</b>	7.13 Typical Characteristics .....	<b>8</b>
<b>2 Applications</b> .....	<b>1</b>	<b>8 Detailed Description</b> .....	<b>9</b>
<b>3 Description</b> .....	<b>1</b>	8.1 Overview .....	<b>9</b>
<b>4 Revision History</b> .....	<b>2</b>	8.2 Functional Block Diagram .....	<b>9</b>
<b>5 Device Comparison Table</b> .....	<b>3</b>	8.3 Feature Description .....	<b>9</b>
<b>6 Pin Configuration and Functions</b> .....	<b>3</b>	8.4 Device Functional Modes .....	<b>10</b>
<b>7 Specifications</b> .....	<b>4</b>	8.5 Programming .....	<b>10</b>
7.1 Absolute Maximum Ratings .....	<b>4</b>	<b>9 Applications and Implementation</b> .....	<b>14</b>
7.2 ESD Ratings .....	<b>4</b>	9.1 Application Information .....	<b>14</b>
7.3 Recommended Operating Conditions .....	<b>4</b>	9.2 Typical Applications .....	<b>15</b>
7.4 Thermal Information .....	<b>5</b>	<b>10 Power Supply Recommendation</b> .....	<b>18</b>
7.5 Supply Current .....	<b>5</b>	10.1 Power Supply Decoupling .....	<b>18</b>
7.6 Digital Input and Output DC Characteristics .....	<b>5</b>	<b>11 Layout</b> .....	<b>19</b>
7.7 LDO Regulator, Wake-Up, and Auto-Shutdown DC Characteristics .....	<b>5</b>	11.1 Layout Guidelines .....	<b>19</b>
7.8 ADC (Temperature and Cell Measurement) Characteristics .....	<b>6</b>	11.2 Layout Example .....	<b>19</b>
7.9 Integrating ADC (Coulomb Counter) Characteristics .....	<b>6</b>	<b>12 Device and Documentation Support</b> .....	<b>20</b>
7.10 Integrated Sense Resistor Characteristics, –40°C to 85°C .....	<b>6</b>	12.1 Documentation Support .....	<b>20</b>
7.11 Integrated Sense Resistor Characteristics, –40°C to 70°C .....	<b>6</b>	12.2 Community Resources .....	<b>20</b>
7.12 I <sup>2</sup> C-Compatible Interface Communication Timing Characteristics .....	<b>6</b>	12.3 Trademarks .....	<b>20</b>
		12.4 Electrostatic Discharge Caution .....	<b>20</b>
		12.5 Glossary .....	<b>20</b>
		<b>13 Mechanical, Packaging, and Orderable Information</b> .....	<b>20</b>

## 4 Revision History

### Changes from Revision D (July 2015) to Revision E Page

• Changed <a href="#">Pin Configuration and Functions</a> .....	<b>3</b>
• Changed <a href="#">Mechanical, Packaging, and Orderable Information</a> .....	<b>20</b>

### Changes from Revision C (December 2014) to Revision D Page

• Changed the <a href="#">Integrated Sense Resistor Characteristics, –40°C to 85°C</a> specifications .....	<b>6</b>
• Changed the <a href="#">Integrated LDO Capacitor</a> section .....	<b>16</b>
• Added <a href="#">Community Resources</a> .....	<b>20</b>

### Changes from Revision B (November 2014) to Revision C Page

• Changed simplified schematic by adding 1-μF capacitor .....	<b>1</b>
• Added description for connecting a 1-μF capacitor .....	<b>3</b>
• Added information for connecting GPOUT .....	<b>3</b>
• Changed connection description for BAT pin .....	<b>18</b>
• Changed "recommend" to "required" .....	<b>19</b>

## 5 Device Comparison Table

PART NUMBER	BATTERY TYPE	CHEM_ID <sup>(1)</sup>	PACKAGE <sup>(2)</sup>	COMMUNICATION FORMAT
bq27421YZFR-G1A	LiCoO <sub>2</sub> (4.2 V maximum charge)	0x128	CSP-9	I <sup>2</sup> C
bq27421YZFT-G1A				
bq27421YZFR-G1B	LiCoO <sub>2</sub> (4.3 V to 4.35 V maximum charge)	0x312		
bq27421YZFT-G1B				
bq27421YZFR-G1D	LiCoO <sub>2</sub> (4.3 V to 4.4 V maximum charge)	0x3142		
bq27421YZFT-G1D				

(1) See the *CHEM\_ID* subcommand to confirm the battery chemistry type.

(2) For the most current package and ordering information see the Package Option Addendum at the end of this document or see the TI website at [www.ti.com](http://www.ti.com).

## 6 Pin Configuration and Functions

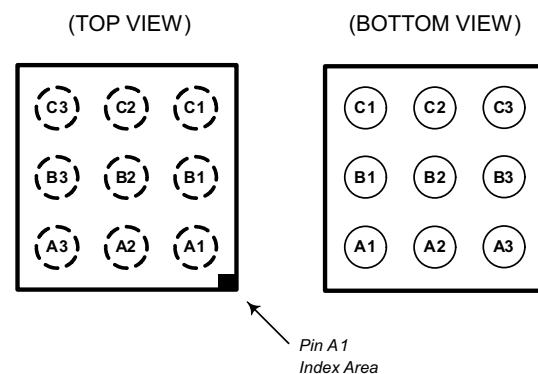

**Pin Functions**

PIN		TYPE <sup>(1)</sup>	DESCRIPTION
NAME	NUMBER		
BAT	C3	PI, AI	LDO regulator input, battery voltage input, and coulomb counter input typically connected to the PACK+ terminal. Connect a capacitor (1 $\mu$ F) between BAT and V <sub>SS</sub> . Place the capacitor close to the gauge.
BIN	B1	DI	Battery insertion detection input. If <b>Operation Configuration</b> bit [ <b>BIE</b> ] = 1 (default), a logic low on the pin is detected as battery insertion. For a removable pack, the BIN pin can be connected to V <sub>SS</sub> through a pull-down resistor on the pack, typically the 10-k $\Omega$ thermistor; the system board should use a 1.8-M $\Omega$ pullup resistor to V <sub>DD</sub> to ensure the BIN pin is high when a battery is removed. If the battery is embedded in the system, it is recommended to leave [ <b>BIE</b> ] = 1 and use a 10-k $\Omega$ pull-down resistor from BIN to V <sub>SS</sub> . If [ <b>BIE</b> ] = 0, then the host must inform the gauge of battery insertion and removal with the <i>BAT_INSERT</i> and <i>BAT_REMOVE</i> subcommands. A 10-k $\Omega$ pull-down resistor should be placed between BIN and V <sub>SS</sub> , even if this pin is unused. <b>NOTE:</b> The BIN pin must not be shorted directly to V <sub>CC</sub> or V <sub>SS</sub> and any pullup resistor on the BIN pin must be connected only to V <sub>DD</sub> and not an external voltage rail.
GPOUT	A1	DO	This open-drain output can be configured to indicate BAT_LOW when the <b>Operation Configuration</b> [ <b>BATLOWEN</b> ] bit is set. By default [ <b>BATLOWEN</b> ] is cleared and this pin performs an interrupt function (SOC_INT) by pulsing for specific events, such as a change in State of Charge. Signal polarity for these functions is controlled by the [ <b>GPIOPOL</b> ] configuration bit. This pin should not be left floating, even if unused, so a 10-k $\Omega$ pullup resistor is recommended. If the device is in SHUTDOWN mode, then toggling GPOUT will make the gauge exit SHUTDOWN. Therefore, it is recommended to connect GPOUT to a GPIO of the host MCU.
SCL	A3	DIO	Slave I <sup>2</sup> C serial bus for communication with system (Master). Open-drain pins. Use with external 10-k $\Omega$ pullup resistors (typical) for each pin. If the external pullup resistors will be disconnected from these pins during normal operation, it is recommended to use external 1-M $\Omega$ pull-down resistors to V <sub>SS</sub> at each pin to avoid floating inputs.
SDA	A2	DIO	
SRX	C2	AI	Integrated high-side sense resistor and coulomb counter input typically connected to system power rail VSYS.

(1) IO = Digital input-output, AI = Analog input, P = Power connection

### Pin Functions (continued)

PIN		TYPE <sup>(1)</sup>	DESCRIPTION
NAME	NUMBER		
V <sub>DD</sub>	B3	PO	1.8-V Regulator Output. Decouple with 0.47- $\mu$ F ceramic capacitor to V <sub>SS</sub> . This pin is not intended to provide power for other devices in the system.
V <sub>SS</sub>	B2, C1	PI	Ground pins. The center pin B2 is the actual device ground pin while pin C1 is floating internally and therefore C1 may be used as a bridge to connect to the board ground plane without requiring a via under the device package. It is recommended to route the center pin B2 to the corner pin C1 using a top-layer metal trace on the board. Then route the corner pin C1 to the board ground plane.

## 7 Specifications

### 7.1 Absolute Maximum Ratings

Over-operating free-air temperature range (unless otherwise noted)<sup>(1)</sup>

		MIN	MAX	UNIT
V <sub>BAT</sub>	BAT pin input voltage range	-0.3	6	V
V <sub>SRX</sub>	SRX pin input voltage range	V <sub>BAT</sub> - 0.3	V <sub>BAT</sub> + 0.3	V
V <sub>DD</sub>	V <sub>DD</sub> pin supply voltage range (LDO output)	-0.3	2	V
V <sub>IOD</sub>	Open-drain IO pins (SDA, SCL, GPOUT)	-0.3	6	V
V <sub>IOPP</sub>	Push-pull IO pins (BIN)	-0.3	V <sub>DD</sub> + 0.3	V
T <sub>A</sub>	Operating free-air temperature range	-40	85	°C
T <sub>stg</sub>	Storage temperature	-65	150	°C

(1) Stresses beyond those listed under "absolute maximum ratings" may cause permanent damage to the device. These are stress ratings only, and functional operation of the device at these or any other conditions beyond those indicated under "recommended operating conditions" is not implied. Exposure to absolute-maximum-rated conditions for extended periods may affect device reliability.

### 7.2 ESD Ratings

		VALUE	UNIT
V <sub>(ESD)</sub>	Electrostatic discharge	Human-body model (HBM), per ANSI/ESDA/JEDEC JS-001 <sup>(1)</sup>	±1500
		Charged-device model (CDM), per JEDEC specification JESD22-C101 <sup>(2)</sup>	±250

(1) JEDEC document JEP155 states that 500-V HBM allows safe manufacturing with a standard ESD control process.

(2) JEDEC document JEP157 states that 250-V CDM allows safe manufacturing with a standard ESD control process.

### 7.3 Recommended Operating Conditions

T<sub>A</sub> = 30°C and V<sub>REGIN</sub> = V<sub>BAT</sub> = 3.6V (unless otherwise noted)

		MIN	NOM	MAX	UNIT
C <sub>BAT</sub> <sup>(1)</sup>	External input capacitor for internal LDO between BAT and V <sub>SS</sub>	Nominal capacitor values specified. A 5% ceramic X5R-type capacitor located close to the device is recommended.		0.1	$\mu$ F
C <sub>LDO18</sub> <sup>(1)</sup>	External output capacitor for internal LDO between V <sub>DD</sub> and V <sub>SS</sub>			0.47	$\mu$ F
V <sub>PU</sub> <sup>(1)</sup>	External pull-up voltage for open-drain pins (SDA, SCL, GPOUT)	1.62		3.6	V

(1) Specified by design. Not production tested.

## 7.4 Thermal Information

THERMAL METRIC <sup>(1)</sup>		bq27421-G1		UNIT
		YZF (DSBGA)		
		9 PINS		
R <sub>θJA</sub>	Junction-to-ambient thermal resistance	107.8		°C/W
R <sub>θJctop</sub>	Junction-to-case (top) thermal resistance	0.7		°C/W
R <sub>θJB</sub>	Junction-to-board thermal resistance	60.4		°C/W
ψ <sub>JT</sub>	Junction-to-top characterization parameter	3.5		°C/W
ψ <sub>JB</sub>	Junction-to-board characterization parameter	60.4		°C/W
R <sub>θJcbot</sub>	Junction-to-case (bottom) thermal resistance	NA		°C/W

(1) For more information about traditional and new thermal metrics, see the IC Package Thermal Metrics application report, [SPRA953](#).

## 7.5 Supply Current

T<sub>A</sub> = 30°C and V<sub>REGIN</sub> = V<sub>BAT</sub> = 3.6 V (unless otherwise noted)

PARAMETER	TEST CONDITIONS	MIN	TYP	MAX	UNIT
I <sub>CC</sub> <sup>(1)</sup>	NORMAL mode current I <sub>LOAD</sub> > <b>Sleep Current</b> <sup>(2)</sup>		93		μA
I <sub>SLP</sub> <sup>(1)</sup>	SLEEP mode current I <sub>LOAD</sub> < <b>Sleep Current</b> <sup>(2)</sup>		21		μA
I <sub>HIB</sub> <sup>(1)</sup>	HIBERNATE mode current I <sub>LOAD</sub> < <b>Hibernate Current</b> <sup>(2)</sup>		9		μA
I <sub>SD</sub> <sup>(1)</sup>	SHUTDOWN mode current Fuel gauge in host commanded SHUTDOWN mode (LDO regulator output disabled)		0.6		μA

(1) Specified by design. Not production tested.

(2) Wake Comparator Disabled.

## 7.6 Digital Input and Output DC Characteristics

T<sub>A</sub> = –40°C to 85°C, typical values at T<sub>A</sub> = 30°C and V<sub>REGIN</sub> = 3.6 V (unless otherwise noted)

PARAMETER	TEST CONDITIONS	MIN	TYP	MAX	UNIT
V <sub>IH(OD)</sub>	Input voltage, high <sup>(2)</sup> External pullup resistor to V <sub>PU</sub>	V <sub>PU</sub> × 0.7			V
V <sub>IL</sub>	Input voltage, low <sup>(2) (3)</sup>			0.6	V
V <sub>OL</sub>	Output voltage, low <sup>(2)</sup>			0.6	V
I <sub>OH</sub>	Output source current, high <sup>(2) (3)</sup>			0.5	mA
I <sub>OL(OD)</sub>	Output sink current, low <sup>(2)</sup>			–3	mA
C <sub>IN</sub> <sup>(1)</sup>	Input capacitance <sup>(2) (3)</sup>			5	pF
I <sub>lkg</sub>	Input leakage current (SCL, SDA, BIN)			0.1	μA
	Input leakage current (GPOUT)			1	

(1) Specified by design. Not production tested.

(2) Open Drain pins: (SCL, SDA, GPOUT)

(3) Push-pull pin: (BIN)

## 7.7 LDO Regulator, Wake-Up, and Auto-Shutdown DC Characteristics

T<sub>A</sub> = –40°C to 85°C, typical values at T<sub>A</sub> = 30°C and V<sub>REGIN</sub> = 3.6 V (unless otherwise noted)

PARAMETER	TEST CONDITIONS	MIN	TYP	MAX	UNIT
V <sub>BAT</sub>	BAT pin regulator input	2.45		4.5	V
V <sub>DD</sub>	Regulator output voltage		1.8		V
UVLO <sub>IT+</sub>	V <sub>BAT</sub> undervoltage lockout LDO wake-up rising threshold		2		V
UVLO <sub>IT–</sub>	V <sub>BAT</sub> undervoltage lockout LDO auto-shutdown falling threshold		1.95		V

(1) Specified by design. Not production tested.

## 7.8 ADC (Temperature and Cell Measurement) Characteristics

 $T_A = -40^{\circ}\text{C}$  to  $85^{\circ}\text{C}$ ; typical values at  $T_A = 30^{\circ}\text{C}$  and  $V_{\text{REGIN}} = 3.6\text{ V}$  (unless otherwise noted)

PARAMETER		TEST CONDITIONS	MIN	TYP	MAX	UNIT
$V_{\text{IN(BAT)}}$	BAT pin voltage measurement range.	Voltage divider enabled.	2.45		4.5	V
$t_{\text{ADC\_CONV}}$	Conversion time			125		ms
	Effective resolution			15		bits

(1) Specified by design. Not tested in production.

## 7.9 Integrating ADC (Coulomb Counter) Characteristics

 $T_A = -40^{\circ}\text{C}$  to  $85^{\circ}\text{C}$ ; typical values at  $T_A = 30^{\circ}\text{C}$  and  $V_{\text{REGIN}} = 3.6\text{ V}$  (unless otherwise noted)

PARAMETER		TEST CONDITIONS	MIN	TYP	MAX	UNIT
$V_{\text{SR}}$	Input voltage range from BAT to SRX pins			BAT $\pm$ 25		mV
$t_{\text{SR\_CONV}}$	Conversion time	Single conversion		1		s
	Effective Resolution	Single conversion		16		bits

(1) Assured by design. Not tested in production.

## 7.10 Integrated Sense Resistor Characteristics, $-40^{\circ}\text{C}$ to $85^{\circ}\text{C}$

 $T_A = -40^{\circ}\text{C}$  to  $85^{\circ}\text{C}$ ; typical values at  $T_A = 30^{\circ}\text{C}$  and  $V_{\text{REGIN}} = 3.6\text{ V}$  (unless otherwise noted)

PARAMETER		TEST CONDITIONS	MIN	TYP	MAX	UNIT
$\text{SRX}_{\text{RES}}$ <sup>(1)</sup>	Resistance of Integrated Sense Resistor from SRX to BAT	$T_A = 30^{\circ}\text{C}$		7		$\text{m}\Omega$
$I_{\text{SRX}}$ <sup>(2)</sup>	Recommended Sense Resistor input current	Long term RMS, average device utilization			2000	mA
		Peak RMS current, 10% device utilization <sup>(3)</sup>			2500	mA
		Peak pulsed current, 250 ms maximum, 1% device utilization, <sup>(3)</sup>			3500	mA

(1) Firmware compensation applied for temperature coefficient of resistor.

(2) Specified by design. Not tested in production.

(3) Device utilization is the long-term usage profile at a specific condition compared to the average condition.

## 7.11 Integrated Sense Resistor Characteristics, $-40^{\circ}\text{C}$ to $70^{\circ}\text{C}$

 $T_A = -40^{\circ}\text{C}$  to  $70^{\circ}\text{C}$ ; typical values at  $T_A = 30^{\circ}\text{C}$  and  $V_{\text{REGIN}} = 3.6\text{ V}$  (unless otherwise noted)

PARAMETER		TEST CONDITIONS	MIN	TYP	MAX	UNIT
$\text{SRX}_{\text{RES}}$ <sup>(1)</sup>	Resistance of Integrated Sense Resistor from SRX to BAT	$T_A = 30^{\circ}\text{C}$		7		$\text{m}\Omega$
$I_{\text{SRX}}$ <sup>(2)</sup>	Recommended Sense Resistor input current	Long term RMS, average device utilization			2000	mA
		Peak RMS current, 10% device utilization <sup>(3)</sup>			3500	mA
		Peak pulsed current, 250 ms maximum, 1% device utilization, <sup>(3)</sup>			4500	mA

(1) Firmware compensation applied for temperature coefficient of resistor.

(2) Specified by design. Not tested in production.

(3) Device utilization is the long-term usage profile at a specific condition compared to the average condition.

## 7.12 I<sup>2</sup>C-Compatible Interface Communication Timing Characteristics

 $T_A = -40^{\circ}\text{C}$  to  $85^{\circ}\text{C}$ ; typical values at  $T_A = 30^{\circ}\text{C}$  and  $V_{\text{REGIN}} = 3.6\text{ V}$  (unless otherwise noted)

	MIN	NOM	MAX	UNIT
<b>STANDARD Mode (100 kHz)</b>				

(1) Specified by design. Not production tested.

**I<sup>2</sup>C-Compatible Interface Communication Timing Characteristics (continued)**

T<sub>A</sub> = -40°C to 85°C; typical values at T<sub>A</sub> = 30°C and V<sub>REGIN</sub> = 3.6 V (unless otherwise noted)

		MIN	NOM	MAX	UNIT
t <sub>d(STA)</sub>	Start to first falling edge of SCL	4			µs
t <sub>w(L)</sub>	SCL pulse duration (low)	4.7			µs
t <sub>w(H)</sub>	SCL pulse duration (high)	4			µs
t <sub>su(STA)</sub>	Setup for repeated start	4.7			µs
t <sub>su(DAT)</sub>	Data setup time	250	Host drives SDA		ns
t <sub>h(DAT)</sub>	Data hold time	0	Host drives SDA		ns
t <sub>su(STOP)</sub>	Setup time for stop	4			µs
t <sub>(BUF)</sub>	Bus free time between stop and start	66	Includes Command Waiting Time		µs
t <sub>f</sub>	SCL or SDA fall time <sup>(1)</sup>			300	ns
t <sub>r</sub>	SCL or SDA rise time <sup>(1)</sup>			300	ns
f <sub>SCL</sub>	Clock frequency <sup>(2)</sup>			100	kHz
<b>FAST Mode (400 kHz)</b>					
t <sub>d(STA)</sub>	Start to first falling edge of SCL	600			ns
t <sub>w(L)</sub>	SCL pulse duration (low)	1300			ns
t <sub>w(H)</sub>	SCL pulse duration (high)	600			ns
t <sub>su(STA)</sub>	Setup for repeated start	600			ns
t <sub>su(DAT)</sub>	Data setup time	100	Host drives SDA		ns
t <sub>h(DAT)</sub>	Data hold time	0	Host drives SDA		ns
t <sub>su(STOP)</sub>	Setup time for stop	600			ns
t <sub>(BUF)</sub>	Bus free time between stop and start	66	Includes Command Waiting Time		µs
t <sub>f</sub>	SCL or SDA fall time <sup>(1)</sup>			300	ns
t <sub>r</sub>	SCL or SDA rise time <sup>(1)</sup>			300	ns
f <sub>SCL</sub>	Clock frequency <sup>(2)</sup>			400	kHz

(2) If the clock frequency (f<sub>SCL</sub>) is > 100 kHz, use 1-byte write commands for proper operation. All other transactions types are supported at 400 kHz. (See and )

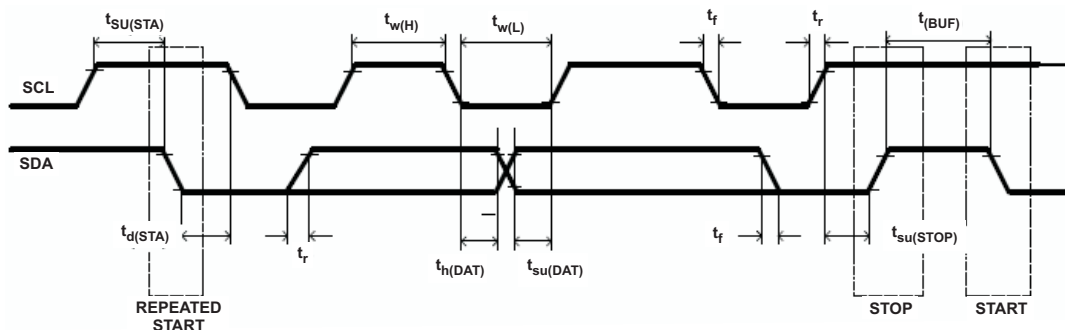

**Figure 1. I<sup>2</sup>C-Compatible Interface Timing Diagrams**

### 7.13 Typical Characteristics

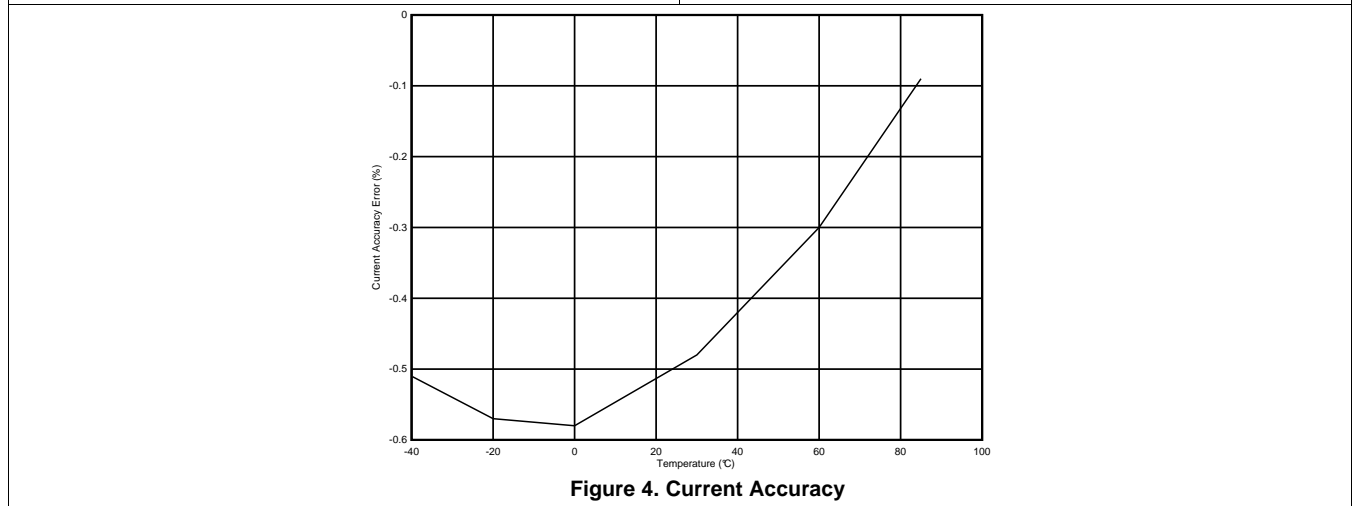
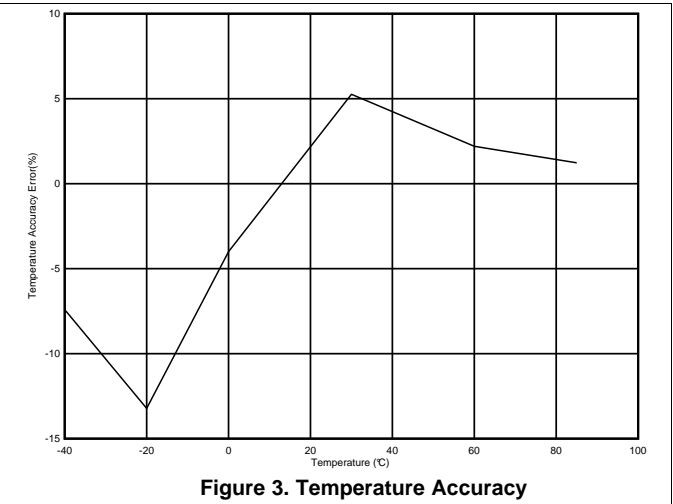
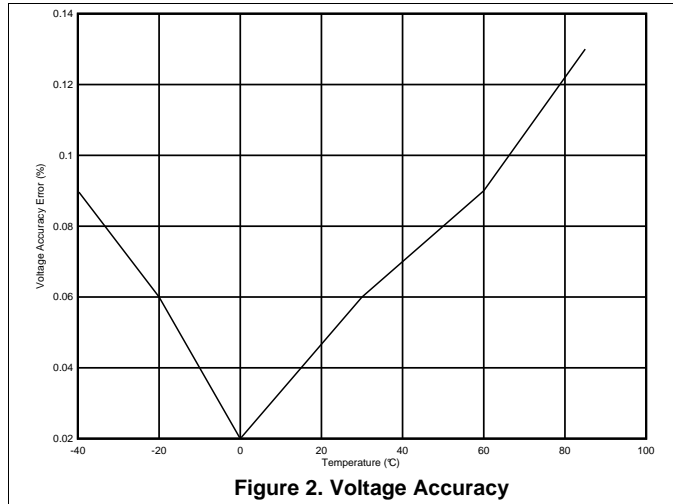

## 8 Detailed Description

### 8.1 Overview

The fuel gauge accurately predicts the battery capacity and other operational characteristics of a single Li-based rechargeable cell. It can be interrogated by a system processor to provide cell information, such as state-of-charge (SOC).

#### NOTE

The following formatting conventions are used in this document:

**Commands:** *italics* with parentheses() and no breaking spaces, for example, *Control()*

**Data Flash:** *italics*, **bold**, and breaking spaces, for example, ***Design Capacity***

**Register bits and flags:** *italics* with brackets [ ], for example, *[TDA]*

**Data Flash bits:** *italics*, **bold**, and brackets [ ], for example, ***[LED1]***

**Modes and states:** ALL CAPITALS, for example, UNSEALED mode

### 8.2 Functional Block Diagram

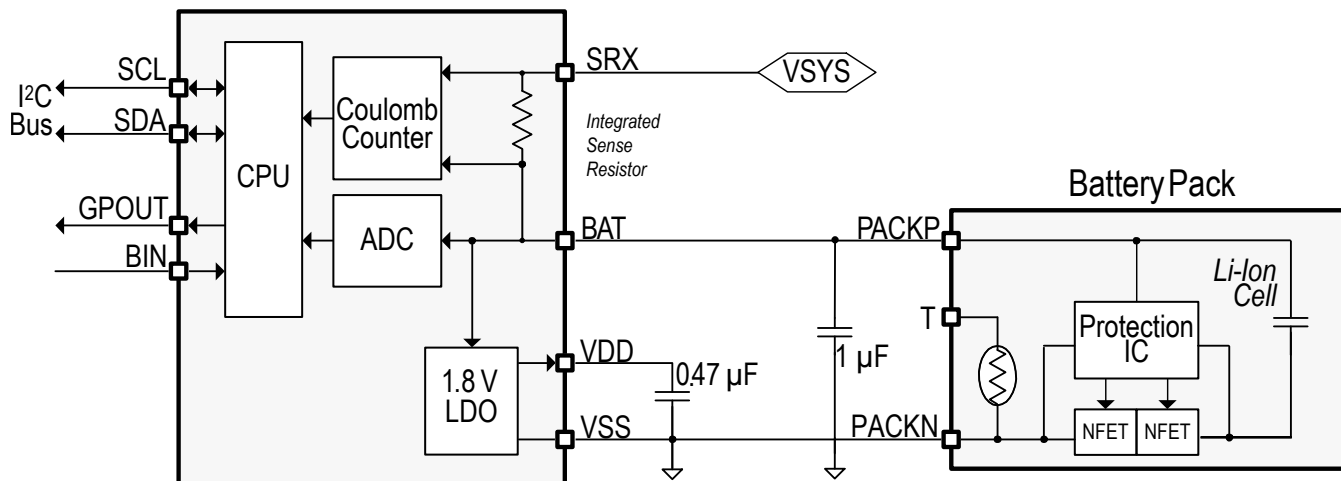

### 8.3 Feature Description

Information is accessed through a series of commands, called *Standard Commands*. Further capabilities are provided by the additional *Extended Commands* set. Both sets of commands, indicated by the general format *Command()*, are used to read and write information contained within the control and status registers, as well as its data locations. Commands are sent from system to gauge using the I<sup>2</sup>C serial communications engine, and can be executed during application development, system manufacture, or end-equipment operation.

The key to the high-accuracy gas gauging prediction is Texas Instruments proprietary Impedance Track™ algorithm. This algorithm uses cell measurements, characteristics, and properties to create state-of-charge predictions that can achieve high-accuracy across a wide variety of operating conditions and over the lifetime of the battery.

The fuel gauge measures the charging and discharging of the battery by monitoring the voltage across a small-value sense resistor. When a cell is attached to the fuel gauge, cell impedance is computed, based on cell current, cell open-circuit voltage (OCV), and cell voltage under loading conditions.

The fuel gauge uses an integrated temperature sensor for estimating cell temperature. Alternatively, the host processor can provide temperature data for the fuel gauge.

## Feature Description (continued)

The *bq27421-G1 Technical Reference Manual* ([SLUUAC5](#)) provides more details.

### 8.4 Device Functional Modes

To minimize power consumption, the fuel gauge has several power modes: INITIALIZATION, NORMAL, SLEEP, HIBERNATE, and SHUTDOWN. The fuel gauge passes automatically between these modes, depending upon the occurrence of specific events, though a system processor can initiate some of these modes directly. See the *bq27421-G1 Technical Reference Manual* ([SLUUAC5](#)) for more details.

### 8.5 Programming

#### 8.5.1 Standard Data Commands

The fuel gauge uses a series of 2-byte standard commands to enable system reading and writing of battery information. Each standard command has an associated command-code pair, as indicated in [Table 1](#). Because each command consists of two bytes of data, two consecutive I<sup>2</sup>C transmissions must be executed both to initiate the command function, and to read or write the corresponding two bytes of data. See the *bq27421-G1 Technical Reference Manual* ([SLUUAC5](#)) for more details.

**Table 1. Standard Commands**

NAME		COMMAND CODE	UNIT	SEALED ACCESS
<i>Control()</i>	CNTL	0x00 and 0x01	NA	RW
<i>Temperature()</i>	TEMP	0x02 and 0x03	0.1°K	RW
<i>Voltage()</i>	VOLT	0x04 and 0x05	mV	R
<i>Flags()</i>	FLAGS	0x06 and 0x07	NA	R
<i>NominalAvailableCapacity()</i>		0x08 and 0x09	mAh	R
<i>FullAvailableCapacity()</i>		0x0A and 0x0B	mAh	R
<i>RemainingCapacity()</i>	RM	0x0C and 0x0D	mAh	R
<i>FullChargeCapacity()</i>	FCC	0x0E and 0x0F	mAh	R
<i>AverageCurrent()</i>		0x10 and 0x11	mA	R
<i>StandbyCurrent()</i>		0x12 and 0x13	mA	R
<i>MaxLoadCurrent()</i>		0x14 and 0x15	mA	R
<i>AveragePower()</i>		0x18 and 0x19	mW	R
<i>StateOfCharge()</i>	SOC	0x1C and 0x1D	%	R
<i>InternalTemperature()</i>		0x1E and 0x1F	0.1°K	R
<i>StateOfHealth()</i>	SOH	0x20 and 0x21	num/%	R
<i>RemainingCapacityUnfiltered()</i>		0x28 and 0x29	mAh	R
<i>RemainingCapacityFiltered()</i>		0x2A and 0x2B	mAh	R
<i>FullChargeCapacityUnfiltered()</i>		0x2C and 0x2D	mAh	R
<i>FullChargeCapacityFiltered()</i>		0x2E and 0x2F	mAh	R
<i>StateOfChargeUnfiltered()</i>		0x30 and 0x31	%	R

### 8.5.2 Control(): 0x00 and 0x01

Issuing a *Control()* command requires a subsequent 2-byte subcommand. These additional bytes specify the particular control function desired. The *Control()* command allows the system to control specific features of the fuel gauge during normal operation and additional features when the device is in different access modes, as described in [Table 2](#). See the *bq27421-G1 Technical Reference Manual (SLUUAC5)* for more details.

**Table 2. Control() Subcommands**

CNTL FUNCTION	CNTL DATA	SEALED ACCESS	DESCRIPTION
CONTROL_STATUS	0x0000	Yes	Reports the status of device
DEVICE_TYPE	0x0001	Yes	Reports the device type (0x0421)
FW_VERSION	0x0002	Yes	Reports the firmware version of the device
DM_CODE	0x0004	Yes	Reports the Data Memory Code number stored in NVM
PREV_MACWRITE	0x0007	Yes	Returns previous MAC command code
CHEM_ID	0x0008	Yes	Reports the chemical identifier of the battery profile used by the fuel gauge
BAT_INSERT	0x000C	Yes	Forces the <i>Flags()</i> [BAT_DET] bit set when the <b>OpConfig [BIE]</b> bit is 0
BAT_REMOVE	0x000D	Yes	Forces the <i>Flags()</i> [BAT_DET] bit clear when the <b>OpConfig [BIE]</b> bit is 0
SET_HIBERNATE	0x0011	Yes	Forces CONTROL_STATUS [HIBERNATE] to 1
CLEAR_HIBERNATE	0x0012	Yes	Forces CONTROL_STATUS [HIBERNATE] to 0
SET_CFGUPDATE	0x0013	No	Force CONTROL_STATUS [CFGUPMODE] to 1 and gauge enters CONFIG UPDATE mode
SHUTDOWN_ENABLE	0x001B	No	Enables device SHUTDOWN mode
SHUTDOWN	0x001C	No	Commands the device to enter SHUTDOWN mode
SEALED	0x0020	No	Places the device in SEALED ACCESS mode
TOGGLE_GPOUT	0x0023	Yes	Commands the device to toggle the GPOUT pin for 1 ms
RESET	0x0041	No	Performs a full device reset
SOFT_RESET	0x0042	No	Gauge exits CONFIG UPDATE mode
EXIT_CFGUPDATE	0x0043	No	Exits CONFIG UPDATE mode without an OCV measurement and without resimulating to update <i>StateOfCharge()</i>
EXIT_RESIM	0x0044	No	Exits CONFIG UPDATE mode without an OCV measurement and resimulates with the updated configuration data to update <i>StateOfCharge()</i>

### 8.5.3 Extended Data Commands

Extended data commands offer additional functionality beyond the standard set of commands. They are used in the same manner; however, unlike standard commands, extended commands are not limited to 2-byte words. The number of command bytes for a given extended command ranges in size from single to multiple bytes, as specified in [Table 3](#).

**Table 3. Extended Commands**

Name	Command Code	Unit	SEALED Access <sup>(1) (2)</sup>	UNSEALED Access <sup>(1) (2)</sup>
<i>OpConfig()</i>	0x3A and 0x3B	NA	R	R
<i>DesignCapacity()</i>	0x3C and 0x3D	mAh	R	R
<i>DataClass()</i> <sup>(2)</sup>	0x3E	NA	NA	RW
<i>DataBlock()</i> <sup>(2)</sup>	0x3F	NA	RW	RW
<i>BlockData()</i>	0x40 through 0x5F	NA	R	RW
<i>BlockDataChecksum()</i>	0x60	NA	RW	RW
<i>BlockDataControl()</i>	0x61	NA	NA	RW
Reserved	0x62 through 0x7F	NA	R	R

(1) SEALED and UNSEALED states are entered via commands to *Control()* 0x00 and 0x01

(2) In SEALED mode, data cannot be accessed through commands 0x3E and 0x3F.

### 8.5.4 Communications

#### 8.5.4.1 I<sup>2</sup>C Interface

The fuel gauge supports the standard I<sup>2</sup>C read, incremental read, quick read, one-byte write, and incremental write functions. The 7-bit device address (ADDR) is the most significant 7 bits of the hex address and is fixed as 1010101. The first 8 bits of the I<sup>2</sup>C protocol are, therefore, 0xAA or 0xAB for write or read, respectively.

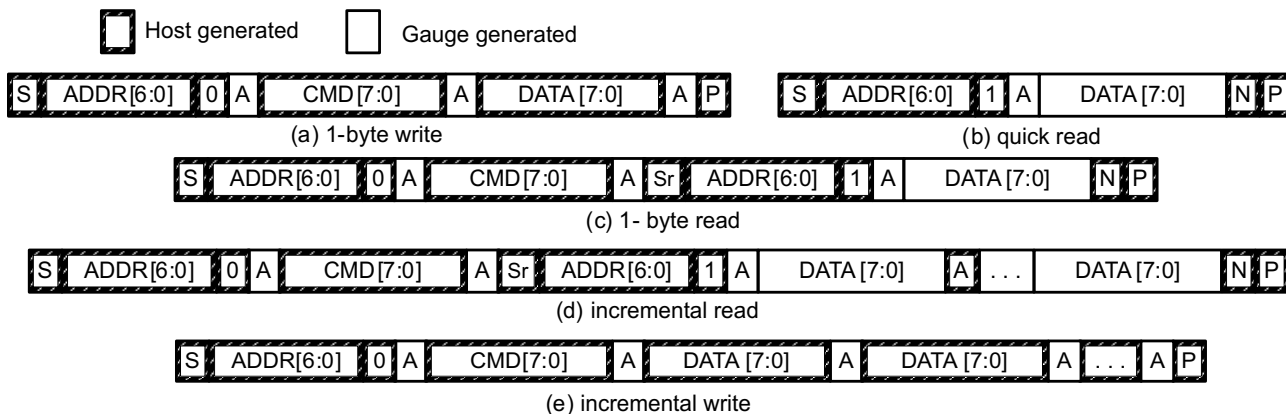

(S = Start, Sr = Repeated Start, A = Acknowledge, N = No Acknowledge, and P = Stop).

**Figure 5. I<sup>2</sup>C Format**

The quick read returns data at the address indicated by the address pointer. The address pointer, a register internal to the I<sup>2</sup>C communication engine, increments whenever data is acknowledged by the fuel gauge or the I<sup>2</sup>C master. “Quick writes” function in the same manner and are a convenient means of sending multiple bytes to consecutive command locations (such as two-byte commands that require two bytes of data).

The following command sequences are not supported:

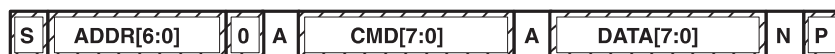

**Figure 6. Attempt To Write a Read-only Address (Nack After Data Sent By Master)**



**Figure 7. Attempt To Read an Address Above 0x6B (Nack Command)**

#### 8.5.4.2 I<sup>2</sup>C Time Out

The I<sup>2</sup>C engine releases both SDA and SCL if the I<sup>2</sup>C bus is held low for 2 seconds. If the fuel gauge is holding the lines, releasing them frees them for the master to drive the lines.

### 8.5.4.3 I<sup>2</sup>C Command Waiting Time

To ensure proper operation at 400 kHz, a  $t_{(BUF)} \geq 66 \mu s$  bus-free waiting time must be inserted between all packets addressed to the fuel gauge. In addition, if the SCL clock frequency ( $f_{SCL}$ ) is  $> 100$  kHz, use individual 1-byte write commands for proper data flow control. The following diagram shows the standard waiting time required between issuing the control subcommand the reading the status result. For read-write standard command, a minimum of 2 seconds is required to get the result updated. For read-only standard commands, there is no waiting time required, but the host must not issue any standard command more than two times per second. Otherwise, the gauge could result in a reset issue due to the expiration of the watchdog timer.

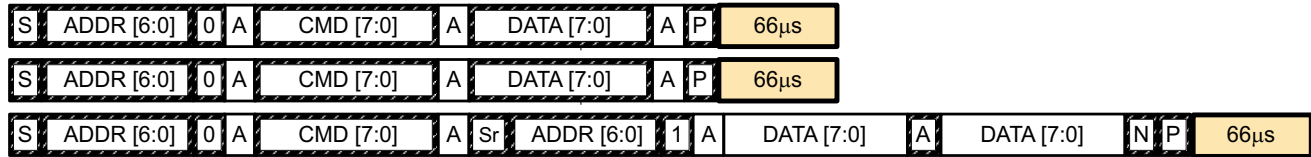

Waiting time inserted between two 1-byte write packets for a subcommand and reading results  
(required for  $100 \text{ kHz} < f_{SCL} \leq 400 \text{ kHz}$ )

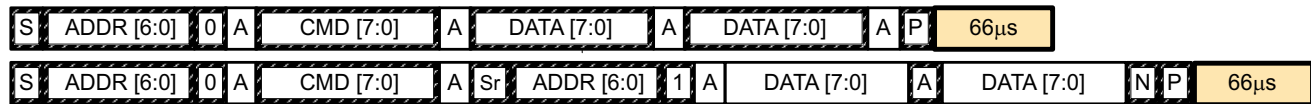

Waiting time inserted between incremental 2-byte write packet for a subcommand and reading results  
(acceptable for  $f_{SCL} \leq 100 \text{ kHz}$ )



Waiting time inserted after incremental read

**Figure 8. I<sup>2</sup>C Command Wait Time**

### 8.5.4.4 I<sup>2</sup>C Clock Stretching

A clock stretch can occur during all modes of fuel gauge operation. In SLEEP and HIBERNATE modes, a short  $\leq 100\text{-}\mu s$  clock stretch occurs on all I<sup>2</sup>C traffic as the device must wake-up to process the packet. In the other modes (INITIALIZATION, NORMAL) a  $\leq 4\text{-ms}$  clock stretching period may occur within packets addressed for the fuel gauge as the I<sup>2</sup>C interface performs normal data flow control.

## 9 Applications and Implementation

---

### NOTE

Information in the following applications sections is not part of the TI component specification, and TI does not warrant its accuracy or completeness. TI's customers are responsible for determining suitability of components for their purposes. Customers should validate and test their design implementation to confirm system functionality.

---

### 9.1 Application Information

The Texas Instruments bq27421-G1 fuel gauge is a microcontroller peripheral that provides system-side fuel gauging for single-cell Li-Ion batteries. The device requires minimal user configuration and system microcontroller firmware. Battery fuel gauging with the bq27421-G1 fuel gauge requires connections only to PACK+ (P+) and PACK– for a removable battery pack or embedded battery circuit.

---

### NOTE

To allow for optimal performance in the end application, special considerations must be taken to ensure minimization of measurement error through proper printed circuit board (PCB) board layout. These requirements are detailed in [Design Requirements](#).

---

## 9.2 Typical Applications

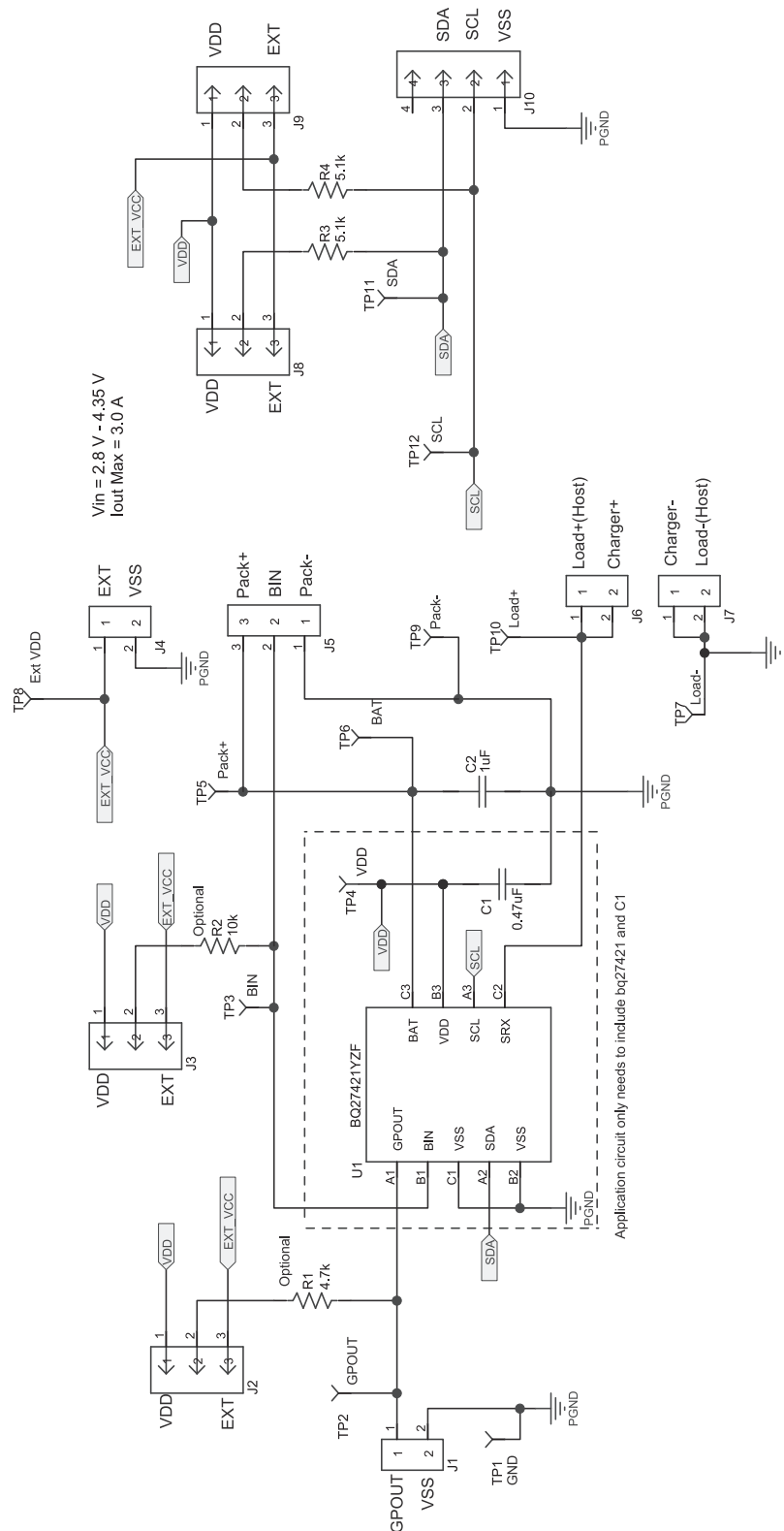

Figure 9. Application Schematic

## Typical Applications (continued)

### 9.2.1 Design Requirements

As shipped from the Texas Instruments factory, many bq27421-G1 parameters in OTP NVM are left in the unprogrammed state (zero) while some parameters directly associated with the CHEMID are preprogrammed. This partially programmed configuration facilitates customization for each end application. Upon device reset, the contents of OTP are copied to associated volatile RAM-based Data Memory blocks. For proper operation, all parameters in RAM-based Data Memory require initialization — either by updating Data Memory parameters in a lab/evaluation situation or by programming the OTP for customer production. The *bq27421-G1 Technical Reference Manual (SLUUAC5)* shows the default value that is present.

### 9.2.2 Detailed Design Procedure

#### 9.2.2.1 BAT Voltage Sense Input

A ceramic capacitor at the input to the BAT pin is used to bypass AC voltage ripple to ground, greatly reducing its influence on battery voltage measurements. It proves most effective in applications with load profiles that exhibit high-frequency current pulses (that is, cell phones) but is recommended for use in all applications to reduce noise on this sensitive high-impedance measurement node.

#### 9.2.2.2 Integrated LDO Capacitor

The fuel gauge has an integrated LDO with an output on the VDD pin of approximately 1.8 V. A capacitor of value at least 0.47  $\mu\text{F}$  should be connected between the VDD pin and VSS. The capacitor should be placed close to the gauge IC and have short traces to both the VDD pin and VSS. This regulator should not be used to provide power for other devices in the system.

#### 9.2.2.3 Sense Resistor Selection

Any variation encountered in the resistance present between the SRP and SRN pins of the fuel gauge will affect the resulting differential voltage, and derived current, it senses. As such, it is recommended to select a sense resistor with minimal tolerance and temperature coefficient of resistance (TCR) characteristics. The standard recommendation based on best compromise between performance and price is a 1% tolerance, 50 ppm drift sense resistor with a 1-W power rating.

**Typical Applications (continued)**

**9.2.3 Application Curves**

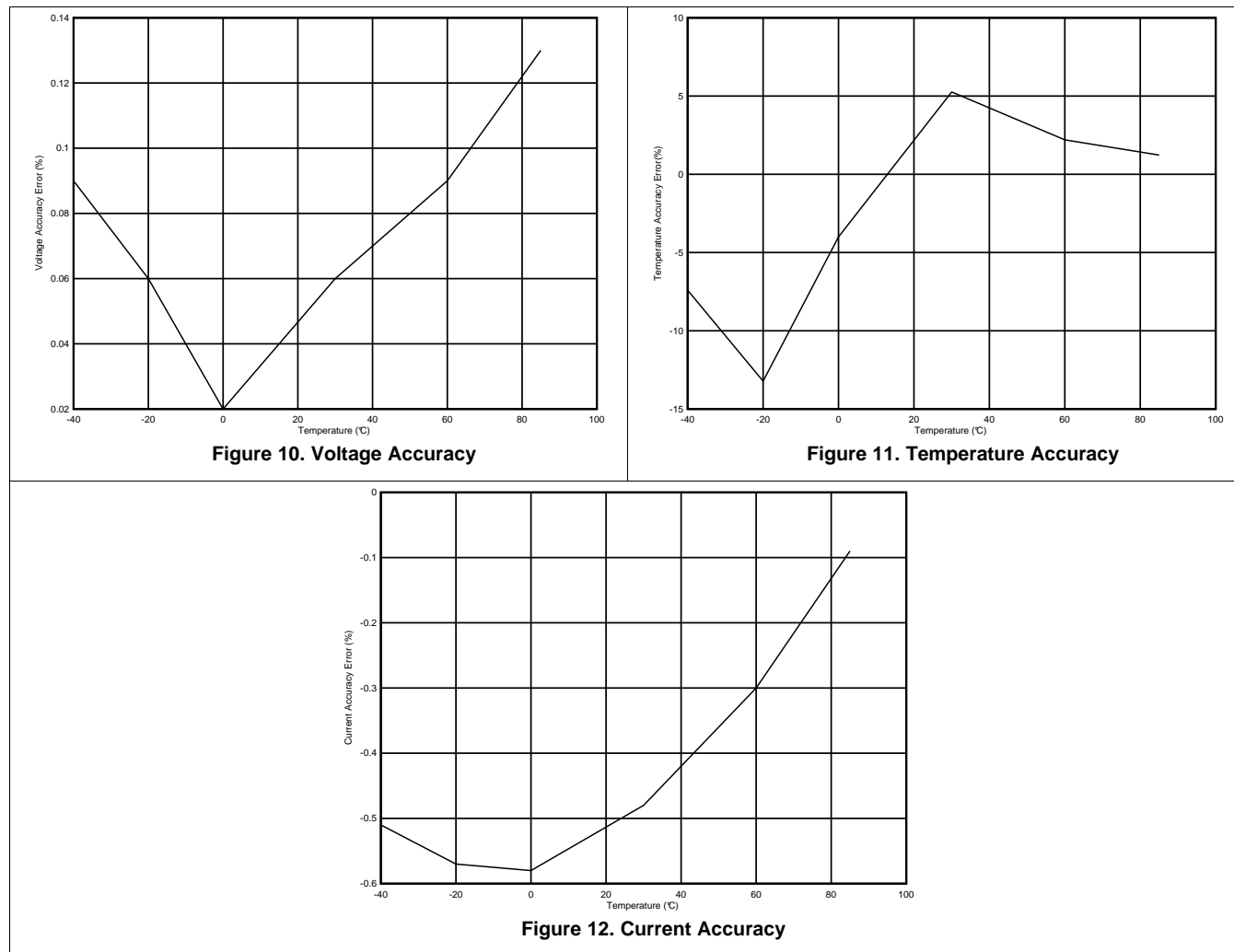

## 10 Power Supply Recommendation

### 10.1 Power Supply Decoupling

The battery connection on the BAT pin is used for two purposes:

- To supply power to the fuel gauge
- As an input for voltage measurement of the battery

A capacitor of value of at least 1  $\mu\text{F}$  should be connected between BAT and  $V_{\text{SS}}$ . The capacitor should be placed close to the gauge IC and have short traces to both the BAT pin and  $V_{\text{SS}}$ .

The fuel gauge has an integrated LDO with an output on the  $V_{\text{DD}}$  pin of approximately 1.8 V. A capacitor of value at least 0.47  $\mu\text{F}$  should be connected between the  $V_{\text{DD}}$  pin and  $V_{\text{SS}}$ . The capacitor should be placed close to the gauge IC and have short traces to both the  $V_{\text{DD}}$  pin and  $V_{\text{SS}}$ .

## 11 Layout

### 11.1 Layout Guidelines

- A capacitor, of value at least 0.47  $\mu\text{F}$ , is connected between the  $V_{\text{DD}}$  pin and  $V_{\text{SS}}$ . The capacitor should be placed close to the gauge IC and have short traces to both the  $V_{\text{DD}}$  pin and  $V_{\text{SS}}$ .
- It is required to have a capacitor, at least 1.0  $\mu\text{F}$ , connected between the BAT pin and  $V_{\text{SS}}$  if the connection between the battery pack and the gauge BAT pin has the potential to pick up noise. The capacitor should be placed close to the gauge IC and have short traces to both the  $V_{\text{DD}}$  pin and  $V_{\text{SS}}$ .
- If the external pullup resistors on the SCL and SDA lines will be disconnected from the host during low-power operation, it is recommended to use external 1-M $\Omega$  pulldown resistors to  $V_{\text{SS}}$  to avoid floating inputs to the I<sup>2</sup>C engine.
- The value of the SCL and SDA pullup resistors should take into consideration the pullup voltage and the bus capacitance. Some recommended values, assuming a bus capacitance of 10 pF, can be seen in Table 4.

Table 4. Recommended Values for SCL and SDA Pullup Resistors

VPU	1.8 V		3.3 V	
R <sub>PU</sub>	Range	Typical	Range	Typical
	$400 \Omega \leq R_{\text{PU}} \leq 37.6 \text{ k}\Omega$	10 k $\Omega$	$900 \Omega \leq R_{\text{PU}} \leq 29.2 \text{ k}\Omega$	5.1 k $\Omega$

- If the GPOUT pin is not used by the host, the pin should still be pulled up to  $V_{\text{DD}}$  with a 4.7-k $\Omega$  or 10-k $\Omega$  resistor.
- If the battery pack thermistor is not connected to the BIN pin, the BIN pin should be pulled down to  $V_{\text{SS}}$  with a 10-k $\Omega$  resistor.
- The BIN pin should not be shorted directly to  $V_{\text{DD}}$  or  $V_{\text{SS}}$ .
- The actual device ground is the center pin (B2). The C1 pin is floating internally and can be used as a bridge to connect the board ground plane to the device ground (B2).

### 11.2 Layout Example

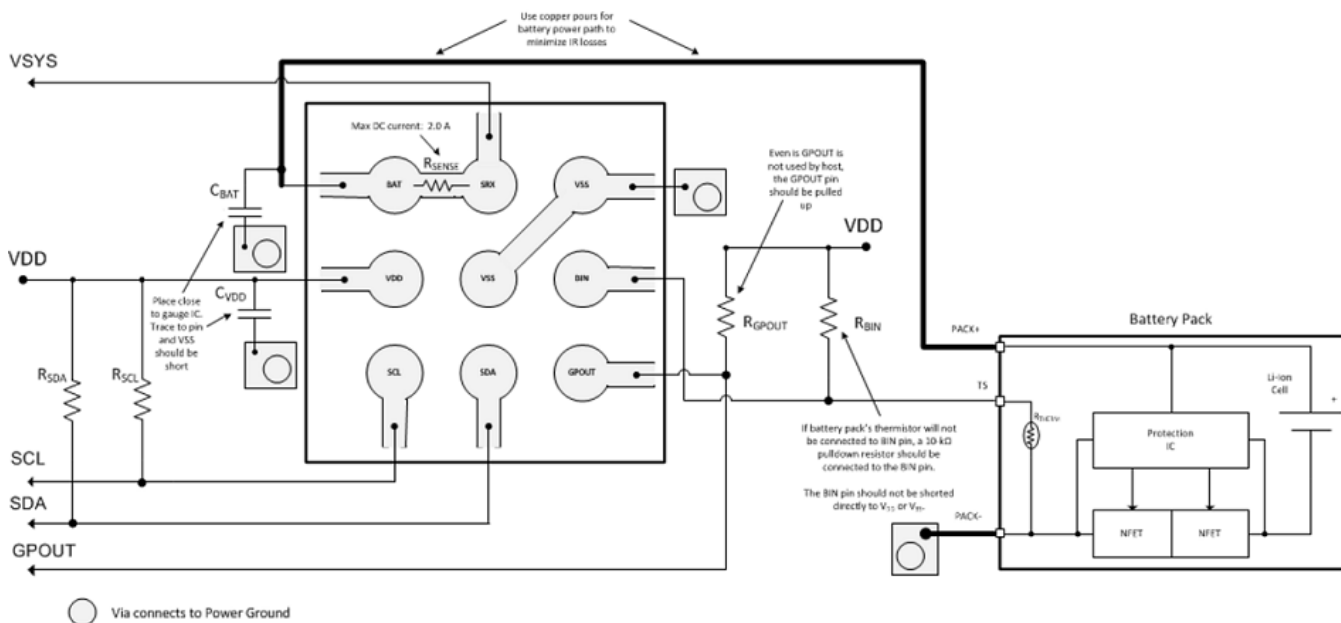

Figure 13. bq27421-G1 Board Layout Example

## 12 Device and Documentation Support

### 12.1 Documentation Support

#### 12.1.1 Related Documentation

- [bq27421-G1 Technical Reference Manual \(SLUUAC5\)](#)
- [bq27421 EVM: Single-Cell Technology User's Guide \(SLUUA63\)](#)
- [Quickstart Guide for bq27421-G1 \(SLUUAH7\)](#)
- [Single Cell Gas Gauge Circuit Design \(SLUA456\)](#)
- [Key Design Considerations for the bq27500 and bq27501 \(SLUA439\)](#)
- [Single Cell Impedance Track Printed-Circuit Board Layout Guide \(SLUA457\)](#)
- [ESD and RF Mitigation in Handheld Battery Electronics \(SLUA460\)](#)

### 12.2 Community Resources

The following links connect to TI community resources. Linked contents are provided "AS IS" by the respective contributors. They do not constitute TI specifications and do not necessarily reflect TI's views; see TI's [Terms of Use](#).

**TI E2E™ Online Community** *TI's Engineer-to-Engineer (E2E) Community*. Created to foster collaboration among engineers. At [e2e.ti.com](http://e2e.ti.com), you can ask questions, share knowledge, explore ideas and help solve problems with fellow engineers.

**Design Support** *TI's Design Support* Quickly find helpful E2E forums along with design support tools and contact information for technical support.

### 12.3 Trademarks

Impedance Track, NanoFree, E2E are trademarks of Texas Instruments. All other trademarks are the property of their respective owners.

### 12.4 Electrostatic Discharge Caution



This integrated circuit can be damaged by ESD. Texas Instruments recommends that all integrated circuits be handled with appropriate precautions. Failure to observe proper handling and installation procedures can cause damage.

ESD damage can range from subtle performance degradation to complete device failure. Precision integrated circuits may be more susceptible to damage because very small parametric changes could cause the device not to meet its published specifications.

### 12.5 Glossary

[SLYZ022](#) — *TI Glossary*.

This glossary lists and explains terms, acronyms, and definitions.

## 13 Mechanical, Packaging, and Orderable Information

The following pages include mechanical, packaging, and orderable information. This information is the most current data available for the designated devices. This data is subject to change without notice and revision of this document. For browser-based versions of this data sheet, refer to the left-hand navigation.

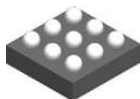

**YZF0009-C01**

**PACKAGE OUTLINE**

**DSBGA - 0.625 mm max height**

DIE SIZE BALL GRID ARRAY

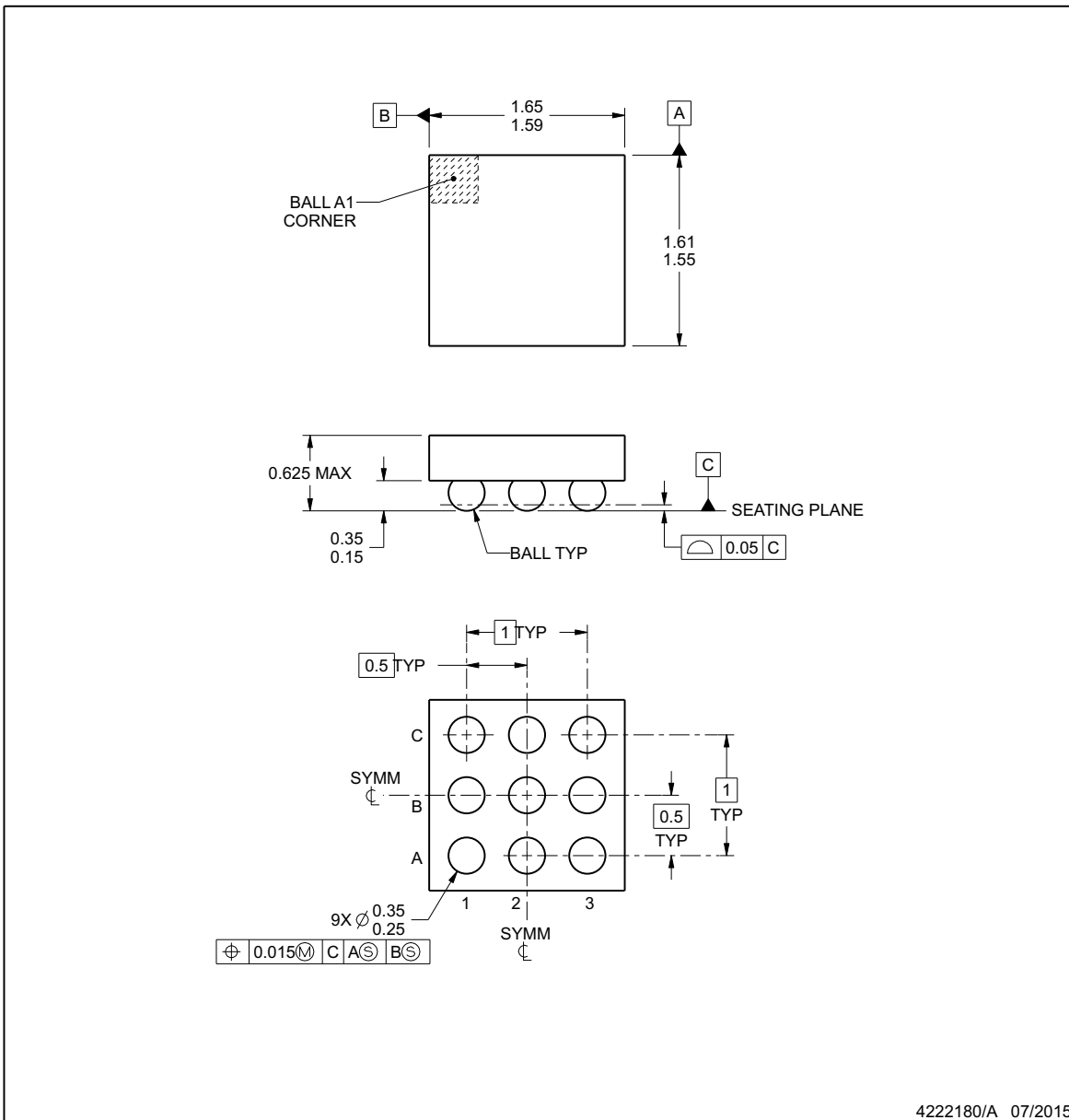

**NOTES:**

NanoFree is a trademark of Texas Instruments.

1. All linear dimensions are in millimeters. Any dimensions in parenthesis are for reference only. Dimensioning and tolerancing per ASME Y14.5M.
2. This drawing is subject to change without notice.
3. NanoFree™ package configuration.

**EXAMPLE BOARD LAYOUT**

**YZF0009-C01**

**DSBGA - 0.625 mm max height**

DIE SIZE BALL GRID ARRAY

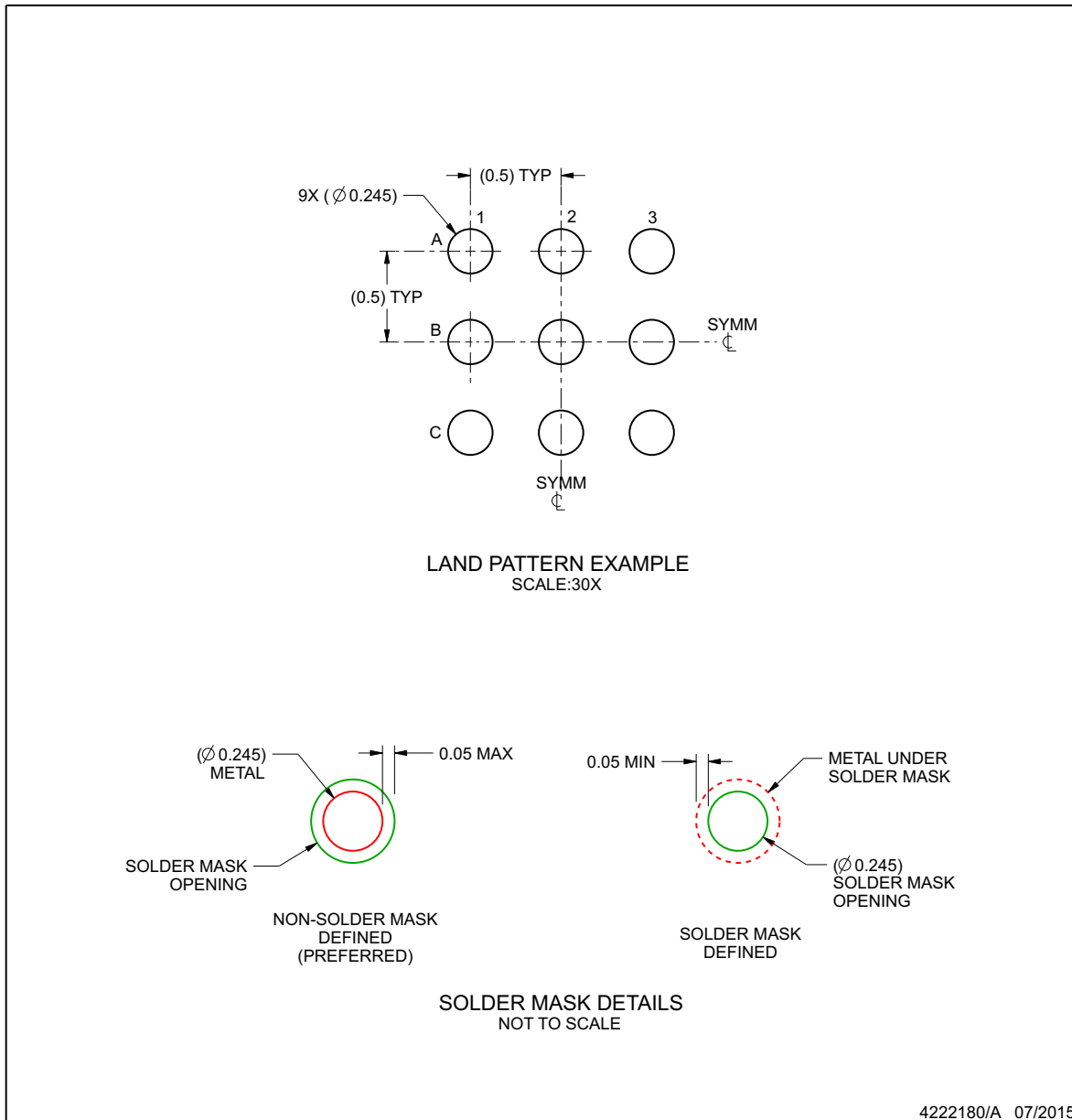

NOTES: (continued)

- Final dimensions may vary due to manufacturing tolerance considerations and also routing constraints. For more information, see Texas Instruments literature number SNVA009 ([www.ti.com/lit/snva009](http://www.ti.com/lit/snva009)).

**EXAMPLE STENCIL DESIGN**

**YZF0009-C01**

**DSBGA - 0.625 mm max height**

DIE SIZE BALL GRID ARRAY

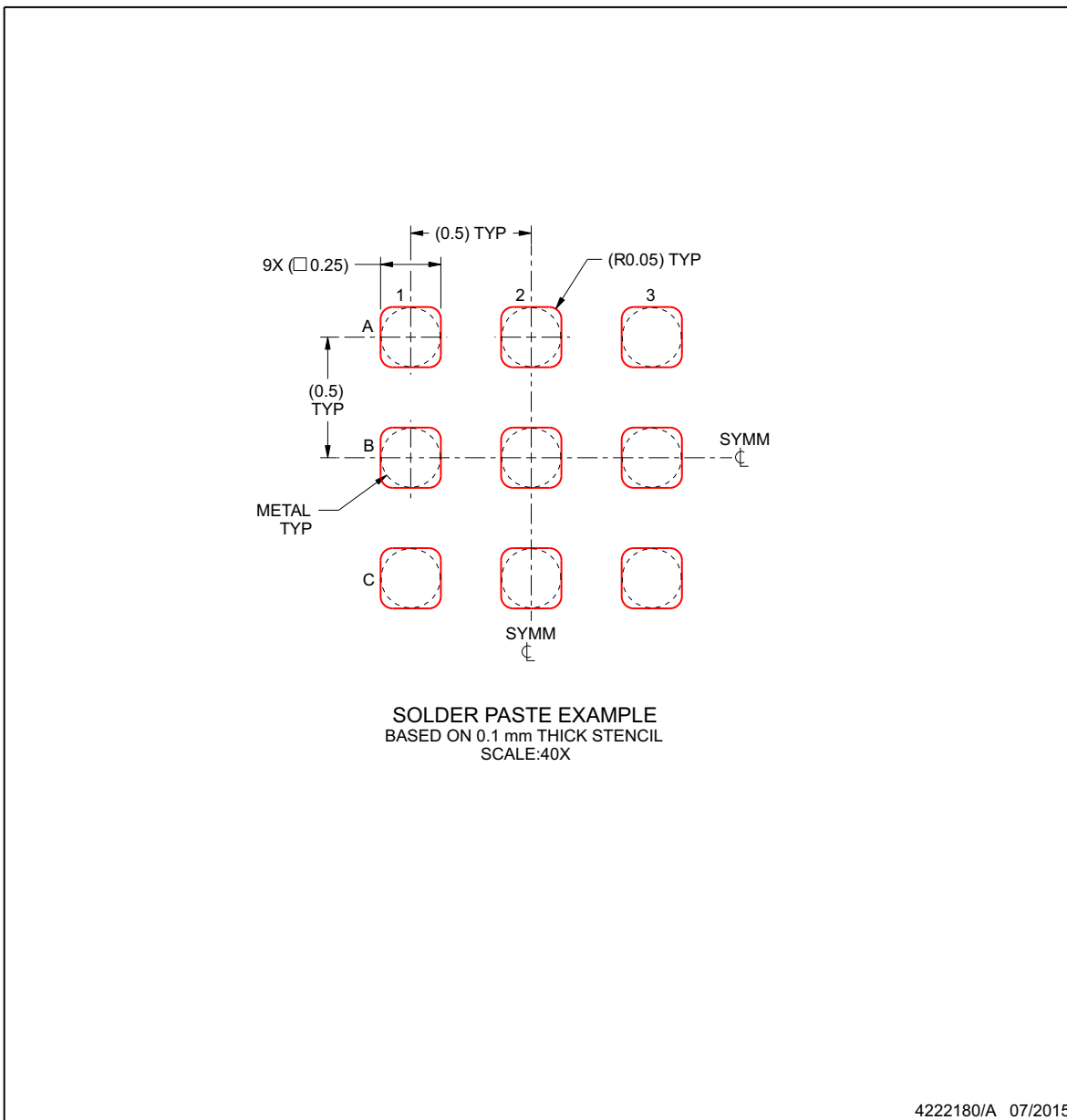

NOTES: (continued)

- 5. Laser cutting apertures with trapezoidal walls and rounded corners may offer better paste release.

## PACKAGING INFORMATION

Orderable Device	Status (1)	Package Type	Package Drawing	Pins	Package Qty	Eco Plan (2)	Lead finish/ Ball material (6)	MSL Peak Temp (3)	Op Temp (°C)	Device Marking (4/5)	Samples
BQ27421YZFR-G1A	ACTIVE	DSBGA	YZF	9	3000	RoHS & Green	SNAGCU	Level-1-260C-UNLIM	-40 to 85	BQ27421 G1A	<a href="#">Samples</a>
BQ27421YZFR-G1B	ACTIVE	DSBGA	YZF	9	3000	RoHS & Green	SNAGCU	Level-1-260C-UNLIM	-40 to 85	BQ27421 G1B	<a href="#">Samples</a>
BQ27421YZFR-G1D	ACTIVE	DSBGA	YZF	9	3000	RoHS & Green	SNAGCU	Level-1-260C-UNLIM	-40 to 85	BQ27421 G1D	<a href="#">Samples</a>
BQ27421YZFT-G1A	ACTIVE	DSBGA	YZF	9	250	RoHS & Green	SNAGCU	Level-1-260C-UNLIM	-40 to 85	BQ27421 G1A	<a href="#">Samples</a>
BQ27421YZFT-G1B	ACTIVE	DSBGA	YZF	9	250	RoHS & Green	SNAGCU	Level-1-260C-UNLIM	-40 to 85	BQ27421 G1B	<a href="#">Samples</a>
BQ27421YZFT-G1D	ACTIVE	DSBGA	YZF	9	250	RoHS & Green	SNAGCU	Level-1-260C-UNLIM	-40 to 85	BQ27421 G1D	<a href="#">Samples</a>

(1) The marketing status values are defined as follows:

**ACTIVE:** Product device recommended for new designs.

**LIFEBUY:** TI has announced that the device will be discontinued, and a lifetime-buy period is in effect.

**NRND:** Not recommended for new designs. Device is in production to support existing customers, but TI does not recommend using this part in a new design.

**PREVIEW:** Device has been announced but is not in production. Samples may or may not be available.

**OBSOLETE:** TI has discontinued the production of the device.

(2) **RoHS:** TI defines "RoHS" to mean semiconductor products that are compliant with the current EU RoHS requirements for all 10 RoHS substances, including the requirement that RoHS substance do not exceed 0.1% by weight in homogeneous materials. Where designed to be soldered at high temperatures, "RoHS" products are suitable for use in specified lead-free processes. TI may reference these types of products as "Pb-Free".

**RoHS Exempt:** TI defines "RoHS Exempt" to mean products that contain lead but are compliant with EU RoHS pursuant to a specific EU RoHS exemption.

**Green:** TI defines "Green" to mean the content of Chlorine (Cl) and Bromine (Br) based flame retardants meet JS709B low halogen requirements of <=1000ppm threshold. Antimony trioxide based flame retardants must also meet the <=1000ppm threshold requirement.

(3) MSL, Peak Temp. - The Moisture Sensitivity Level rating according to the JEDEC industry standard classifications, and peak solder temperature.

(4) There may be additional marking, which relates to the logo, the lot trace code information, or the environmental category on the device.

(5) Multiple Device Markings will be inside parentheses. Only one Device Marking contained in parentheses and separated by a "~" will appear on a device. If a line is indented then it is a continuation of the previous line and the two combined represent the entire Device Marking for that device.

<sup>(6)</sup> Lead finish/Ball material - Orderable Devices may have multiple material finish options. Finish options are separated by a vertical ruled line. Lead finish/Ball material values may wrap to two lines if the finish value exceeds the maximum column width.

**Important Information and Disclaimer:**The information provided on this page represents TI's knowledge and belief as of the date that it is provided. TI bases its knowledge and belief on information provided by third parties, and makes no representation or warranty as to the accuracy of such information. Efforts are underway to better integrate information from third parties. TI has taken and continues to take reasonable steps to provide representative and accurate information but may not have conducted destructive testing or chemical analysis on incoming materials and chemicals. TI and TI suppliers consider certain information to be proprietary, and thus CAS numbers and other limited information may not be available for release.

In no event shall TI's liability arising out of such information exceed the total purchase price of the TI part(s) at issue in this document sold by TI to Customer on an annual basis.

## TAPE AND REEL INFORMATION



### QUADRANT ASSIGNMENTS FOR PIN 1 ORIENTATION IN TAPE



\*All dimensions are nominal

Device	Package Type	Package Drawing	Pins	SPQ	Reel Diameter (mm)	Reel Width W1 (mm)	A0 (mm)	B0 (mm)	K0 (mm)	P1 (mm)	W (mm)	Pin1 Quadrant
BQ27421YZFR-G1A	DSBGA	YZF	9	3000	180.0	8.4	1.78	1.78	0.69	4.0	8.0	Q1
BQ27421YZFR-G1B	DSBGA	YZF	9	3000	180.0	8.4	1.78	1.78	0.69	4.0	8.0	Q1
BQ27421YZFR-G1D	DSBGA	YZF	9	3000	180.0	8.4	1.78	1.78	0.69	4.0	8.0	Q1
BQ27421YZFT-G1A	DSBGA	YZF	9	250	180.0	8.4	1.78	1.78	0.69	4.0	8.0	Q1
BQ27421YZFT-G1B	DSBGA	YZF	9	250	180.0	8.4	1.78	1.78	0.69	4.0	8.0	Q1
BQ27421YZFT-G1D	DSBGA	YZF	9	250	180.0	8.4	1.78	1.78	0.69	4.0	8.0	Q1

**TAPE AND REEL BOX DIMENSIONS**

\*All dimensions are nominal

Device	Package Type	Package Drawing	Pins	SPQ	Length (mm)	Width (mm)	Height (mm)
BQ27421YZFR-G1A	DSBGA	YZF	9	3000	182.0	182.0	20.0
BQ27421YZFR-G1B	DSBGA	YZF	9	3000	182.0	182.0	20.0
BQ27421YZFR-G1D	DSBGA	YZF	9	3000	182.0	182.0	20.0
BQ27421YZFT-G1A	DSBGA	YZF	9	250	182.0	182.0	20.0
BQ27421YZFT-G1B	DSBGA	YZF	9	250	182.0	182.0	20.0
BQ27421YZFT-G1D	DSBGA	YZF	9	250	182.0	182.0	20.0

## IMPORTANT NOTICE AND DISCLAIMER

TI PROVIDES TECHNICAL AND RELIABILITY DATA (INCLUDING DATA SHEETS), DESIGN RESOURCES (INCLUDING REFERENCE DESIGNS), APPLICATION OR OTHER DESIGN ADVICE, WEB TOOLS, SAFETY INFORMATION, AND OTHER RESOURCES "AS IS" AND WITH ALL FAULTS, AND DISCLAIMS ALL WARRANTIES, EXPRESS AND IMPLIED, INCLUDING WITHOUT LIMITATION ANY IMPLIED WARRANTIES OF MERCHANTABILITY, FITNESS FOR A PARTICULAR PURPOSE OR NON-INFRINGEMENT OF THIRD PARTY INTELLECTUAL PROPERTY RIGHTS.

These resources are intended for skilled developers designing with TI products. You are solely responsible for (1) selecting the appropriate TI products for your application, (2) designing, validating and testing your application, and (3) ensuring your application meets applicable standards, and any other safety, security, regulatory or other requirements.

These resources are subject to change without notice. TI grants you permission to use these resources only for development of an application that uses the TI products described in the resource. Other reproduction and display of these resources is prohibited. No license is granted to any other TI intellectual property right or to any third party intellectual property right. TI disclaims responsibility for, and you will fully indemnify TI and its representatives against, any claims, damages, costs, losses, and liabilities arising out of your use of these resources.

TI's products are provided subject to [TI's Terms of Sale](#) or other applicable terms available either on [ti.com](https://www.ti.com) or provided in conjunction with such TI products. TI's provision of these resources does not expand or otherwise alter TI's applicable warranties or warranty disclaimers for TI products.

TI objects to and rejects any additional or different terms you may have proposed.

Mailing Address: Texas Instruments, Post Office Box 655303, Dallas, Texas 75265  
Copyright © 2023, Texas Instruments Incorporated

## Looking for pricing, stock, or lifecycle information?

Click below to explore more details on WIN SOURCE:

 [View BQ27421YZFR-G1A on WIN SOURCE](#)

 [Texas Instruments](#) Information

## Optimize Your Supply Chain with WIN SOURCE Solutions

-  Global Sourcing Solution
-  Obsolete Management
-  Cost Control Management
-  Shortage Management
-  Alternative Solution
-  Excess Inventory Management