

Features

- Supply Voltage up to 40V
- R_{DSon} Typically 0.8 Ω at 25°C, Maximum 1.5 Ω at 150°C
- Up to 1.0A Output Current
- Three Half-bridge Outputs Formed by Three High-side and Three Low-side Drivers
- Capable of Switching Loads such as DC Motors, Bulbs, Resistors, Capacitors, and Inductors
- PWM Capability up to 25kHz for Each High-side Output Controlled by External PWM Signal
- No Shoot-through Current
- Very Low Quiescent Current $I_{VS} < 2\mu A$ in Standby Mode over Total Temperature Range
- Outputs Short-circuit Protected
- Selective Overtemperature Protection for Each Switch and Overtemperature Prewarning
- Undervoltage Protection
- Various Diagnostic Functions such as Shorted Output, Open Load, Overtemperature and Power-supply Fail Detection
- Serial Data Interface, Daisy Chain Capable, up to 2MHz Clock Frequency
- QFN18 Package

1. Description

The Atmel® ATA6831C provides fully protected driver interfaces designed in SOI technology. They are used to allow a microcontroller to control up to three different loads in automotive and industrial applications.

Each of the three high-side and three low-side drivers is capable of driving currents up to 1.0A. Due to the enhanced PWM signal (up to 25kHz) it is possible to generate a smooth control of, for example, a DC motor without any noise. The drivers are internally connected to form three half-bridges and can be controlled separately from a standard serial data interface, enabling all kinds of loads, such as bulbs, resistors, capacitors and inductors, to be combined. The IC design especially supports the application of H-bridges to drive DC motors.

Protection is guaranteed with respect to short-circuit conditions, overtemperature and undervoltage. Various diagnostic functions and a very low quiescent current in standby mode enable a wide range of applications. Automotive qualification (protection against conducted interferences, EMC protection and 2-kV ESD protection) gives added value and enhanced quality for exacting requirements of automotive applications.



Triple Half-bridge Driver with SPI and PWM

Atmel
ATA6831C

Preliminary



Figure 1-1. Block Diagram

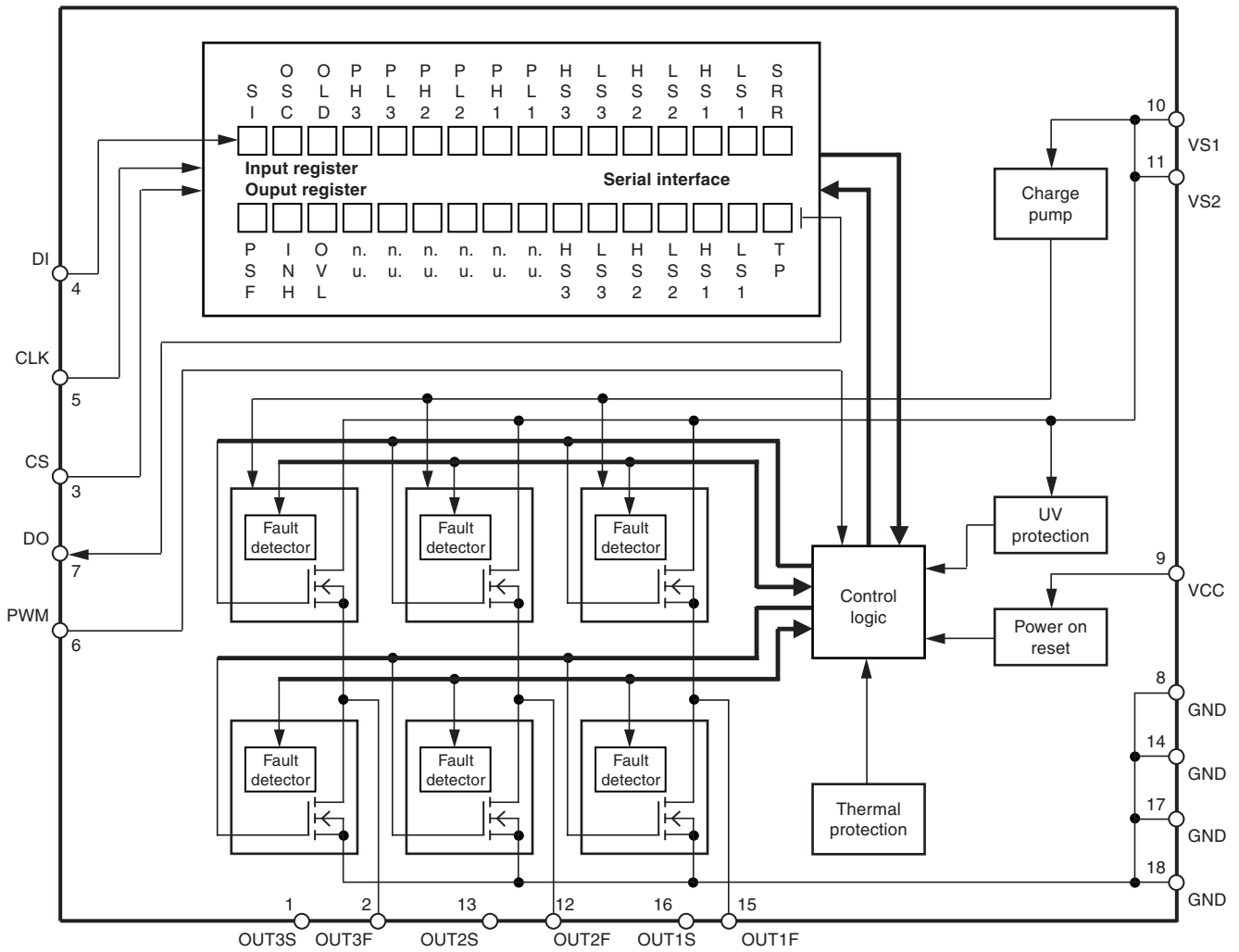

2. Pin Configuration

Figure 2-1. Pinning QFN18

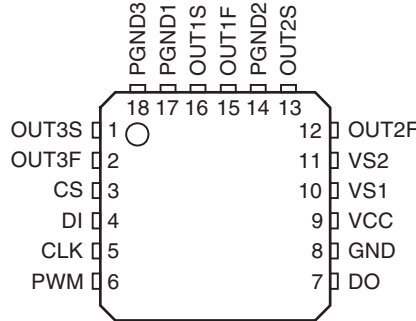

Table 2-1. Pin Description

Pin	Symbol	Function
1	OUT3S	Used only for final testing, to be connected to OUT3F
2	OUT3F	Half-bridge output 3; formed by internally connecting power MOS high-side switch 3 and low-side switch 3 with internal reverse diodes; short circuit protection; overtemperature protection; diagnosis for short and open load
3	CS	Chip select input; 5V CMOS logic level input with internal pull-up; low = serial communication is enabled, high = disabled
4	DI	Serial data input; 5V CMOS logic level input with internal pull-down; receives serial data from the control device; DI expects a 16-bit control word with LSB transferred first
5	CLK	Serial clock input; 5V CMOS logic level input with internal pull-down; controls serial data input interface and internal shift register ($f_{max} = 2\text{MHz}$)
6	PWM	PWM input; 5V CMOS logic level input with internal pull-down
7	DO	Serial data output; 5V CMOS logic-level tri-state output for output (status) register data; sends 16-bit status information to the microcontroller (LSB transferred first); output will remain tri-stated unless device is selected by CS = low; this allows several ICs to operate on only one data-output line
8	GND	Ground
9	VCC	Logic supply voltage (5V)
10	VS1	Power supply for output stages OUT1 and OUT2; internal supply
11	VS2	Power supply for output stages OUT2 and OUT3; internal supply
12	OUT2F	Half-bridge output 2; formed by internally connected power MOS high-side switch 2 and low-side switch 2 with internal reverse diodes; short circuit protection; overtemperature protection; diagnosis for short and open load
13	OUT2S	Used only for final testing, to be connected to OUT2F
14	PGND2	Power ground OUT2
15	OUT1F	Half-bridge output 1; formed by internally connected power MOS high-side switch 1 and low-side switch 1 with internal reverse diodes; short circuit protection; overtemperature protection; diagnosis for short and open load
16	OUT1S	Used only for final testing, to be connected to OUT1F
17	PGND1	Power ground OUT1
18	PGND3	Power ground OUT3

3. Functional Description

3.1 Serial Interface

Data transfer starts with the falling edge of the CS signal. Data must appear at DI synchronized to CLK and is accepted on the falling edge of the CLK signal. The LSB (bit 0, SRR) has to be transferred first. Execution of new input data is enabled on the rising edge of the CS signal. When CS is high, pin DO is in tri-state condition. This output is enabled on the falling edge of CS. Output data will change their state with the rising edge of CLK and stay stable until the next rising edge of CLK appears. LSB (bit 0, TP) is transferred first.

Figure 3-1. Data Transfer

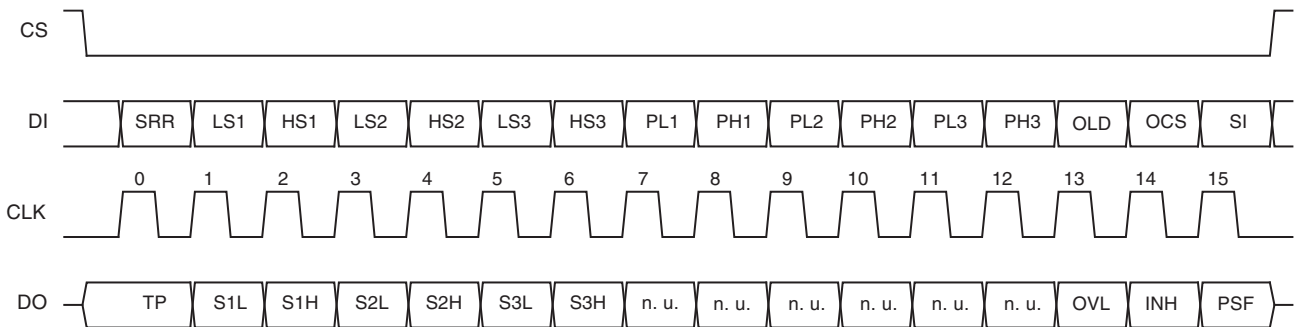

Table 3-1. Input Data Protocol

Bit	Input Register	Function
0	SRR	Status register reset (high = reset; the bits PSF and OVL in the output data register are set to low)
1	LS1	Controls output LS1 (high = switch output LS1 on)
2	HS1	Controls output HS1 (high = switch output HS1 on)
3	LS2	See LS1
4	HS2	See HS1
5	LS3	See LS1
6	HS3	See HS1
7	PL1	Output LS1 additionally controlled by PWM Input
8	PH1	Output HS1 additionally controlled by PWM Input
9	PL2	See PL1
10	PH2	See PH1
11	PL3	See PL1
12	PH3	See PH1
13	OLD	Open load detection (low = on)
14	OCS	Overcurrent shutdown (high = overcurrent shutdown is active)
15	SI	Software inhibit; low = standby, high = normal operation (data transfer is not affected by the standby function because the digital part is still powered)

Table 3-2. Output Data Protocol

Bit	Output (Status) Register	Function
0	TP	Temperature prewarning: high = warning
1	Status LS1	Normal operation: high = output is on, low = output is off Open-load detection: high = open load, low = no open load (correct load condition is detected if the corresponding output is switched off); not affected by SRR
2	Status HS1	Normal operation: high = output is on, low = output is off Open-load detection: high = open load, low = no open load (correct load condition is detected if the corresponding output is switched off); not affected by SRR
3	Status LS2	Description see LS1
4	Status HS2	Description see HS1
5	Status LS3	Description see LS1
6	Status HS3	Description see HS1
7	n. u.	Not used
8	n. u.	Not used
9	n. u.	Not used
10	n. u.	Not used
11	n. u.	Not used
12	n. u.	Not used
13	OVL	Over-load detected: set high, when at least one output is switched off by a short-circuit condition or an overtemperature event. Bits 1 to 6 can be used to detect the affected switch
14	INH	Inhibit: this bit is controlled by software (bit SI in input register) High = standby, low = normal operation
15	PSF	Power-supply fail: undervoltage at pin VS detected

After power-on reset, the input register has the following status:

Bit 15	Bit 14	Bit 13	Bit 12	Bit 11	Bit 10	Bit 9	Bit 8	Bit 7	Bit 6	Bit 5	Bit 4	Bit 3	Bit 2	Bit 1	Bit 0
SI	OCS	OLD	PH3	PL3	PH2	PL2	PH1	PL1	HS3	LS3	HS2	LS2	HS1	LS1	SRR
H	H	H	L	L	L	L	L	L	L	L	L	L	L	L	L

The following patterns are used to enable internal test modes of the IC. Do not use these patterns during normal operation.

Bit 15	Bit 14	Bit 13	Bit 12	Bit 11	Bit 10	Bit 9	Bit 8	Bit 7	Bit 6	Bit 5	Bit 4	Bit 3	Bit 2	Bit 1	Bit 0
		(OCS)							(HS3)	(LS3)	(HS2)	(LS2)	(HS1)	(LS1)	(SRR)
H	H	H	H	H	L	L	L	L	L	L	L	L	L	L	L
H	H	H	L	L	H	H	L	L	L	L	L	L	L	L	L
H	H	H	L	L	L	L	H	H	L	L	L	L	L	L	L

3.2 Power-supply Fail

If undervoltage is detected at pin VS, the power-supply fail bit (PSF) in the output register is set and all outputs are disabled. To detect an undervoltage, its duration has to last longer than the undervoltage detection delay time t_{dUV} . The outputs are enabled immediately when the supply voltage returns to the normal operational value. The PSF bit stays high until it is reset by the SRR bit in the input register.

3.3 Open-load Detection

If the open-load detection bit (OLD) is set to low, a pull-up current for each high-side switch and a pull-down current for each low-side switch is turned on (open-load detection current I_{Out1-3}).

The open load condition of all the outputs is indicated in the SPI output register bit 1-6. High-side open load is detected in case of OUT1-3 voltage above maximum voltage $V_{OUT1-3_OLD_HTH}$ while Low-side open load is detected in case of OUT1-3 voltage below minimum voltage $V_{OUT1-3_OLD_LTh}$, see [Figure 3-2](#).

If the OUTx is not connected, a Low-side open load is indicated, because the low-side current sink is higher than the high-side current source, see open load detection current ratio $I_{Out1-3L}/I_{Out1-3H}$.

Switching on an output stage with the OLD bit set to low disables the open-load function for this output.

Figure 3-2. OLD Threshold Level

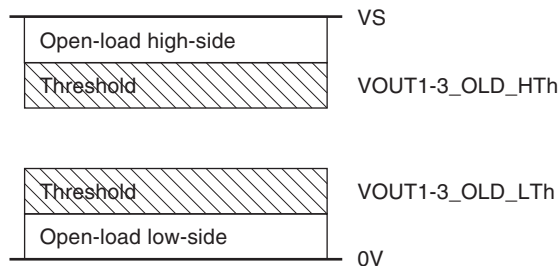

3.4 Overtemperature Protection

If the junction temperature of one or more output stages exceeds the thermal prewarning threshold, $T_{jPW\ set}$, the temperature prewarning bit (TP) in the output register is set. When the temperature falls below the thermal prewarning threshold, $T_{jPW\ reset}$, the bit TP is reset. The TP bit can be read without transferring a complete 16-bit data word. The status of TP is available at pin DO with the falling edge of CS. After the microcontroller has read this information, CS is set high and the data transfer is interrupted without affecting the status of input and output registers.

If the junction temperature of an output stage exceeds the thermal shutdown threshold, $T_{jswitch\ off}$, the affected output is disabled and the corresponding bit in the output register is set to low. Additionally, the overload detection bit (OVL) in the output register is set. The output can be enabled again when the temperature falls below the thermal shutdown threshold, $T_{jswitch\ on}$, and the SRR bit in the input register is set to high. The hysteresis of thermal prewarning and shutdown threshold avoids oscillations.

3.5 Short-circuit Protection

The output currents are limited by a current regulator. Overcurrent detection is activated by writing a high to the overcurrent shutdown bit (OCS) bit in the input register. When the current in an output stage exceeds the overcurrent limitation and shut-down threshold, it is switched off, following a delay time (t_{dSd}). The over-load detection bit (OVL) is set and the corresponding status bit in the output register is set to low. For OCS = low, the overcurrent shutdown is inactive and the OVL bit is not set by an overcurrent. By writing a high to the SRR bit in the input register the OVL bit is reset and the disabled outputs are enabled.

3.6 Inhibit

The SI bit in the input register has to be set to zero to inhibit the Atmel® ATA6831C.

In this state, all output stages are then turned off but the serial interface remains active. The current consumption is reduced to less than $2\mu A$ at pin VS and less than $100\mu A$ at pin VCC. The output stages can be reactivated by setting bit SI to “1”.

3.7 PWM Mode

The common input for all six outputs is pin PWM (Figure 3-3). The selection of the outputs, which are controlled by PWM, is done by input data register PLx or PHx. In addition to the PWM input register, the corresponding input registers HSx and LSs have to be set.

Switching the high side outputs is possible up to 25kHz, low side switches up to 8kHz.

Figure 3-3. Output Control by PWM

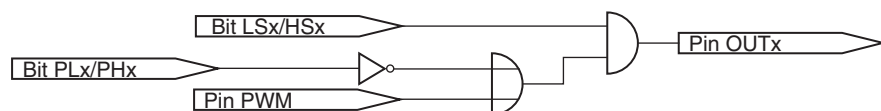



4. Absolute Maximum Ratings

Stresses beyond those listed under “Absolute Maximum Ratings” may cause permanent damage to the device. This is a stress rating only and functional operation of the device at these or any other conditions beyond those indicated in the operational sections of this specification is not implied. Exposure to absolute maximum rating conditions for extended periods may affect device reliability.

Parameters	Pin	Symbol	Value	Unit
Supply voltage	10, 11	V_{VS}	-0.3 to +40	V
Supply voltage $t < 0.5s$; $I_{VS} > -2A$	10, 11	V_{VS}	-1	V
Logic supply voltage	9	V_{VCC}	-0.3 to +7	V
Logic input voltage	3, 4, 5, 6	$V_{CS}, V_{DI}, V_{CLK}, V_{PWM}$	-0.3 to $V_{VCC} + 0.3$	V
Logic output voltage	7	V_{DO}	-0.3 to $V_{VCC} + 0.3$	V
Input current	3, 4, 5, 6	$I_{CS}, I_{DI}, I_{CLK}, I_{PWM}$	-10 to +10	mA
Output current	7	I_{DO}	-10 to +10	mA
Output current	2, 12, 15	$I_{Out1}, I_{Out2}, I_{Out3}$	Internally limited, see output specification	
Output voltage	2, 12, 15	$I_{Out1}, I_{Out2}, I_{Out3}$	-0.3 to +40	V
Reverse conducting current ($t_{pulse} = 150\mu s$)	2, 12, 15	$I_{Out1}, I_{Out2}, I_{Out3}$	17	A
Junction temperature range		T_J	-40 to +150	°C
Storage temperature range		T_{STG}	-55 to +150	°C

5. Thermal Resistance

Parameters	Test Conditions	Symbol	Value	Unit
Thermal resistance from junction to case		R_{thJC}	5	k/W
Thermal resistance from junction to ambient	Depends on the PC board	R_{thJA}	40	K/W

6. Operating Range

Parameters	Symbol	Value	Unit
Supply voltage	V_{VS}	$V_{UV}^{(1)}$ to 40	V
Logic supply voltage	V_{VCC}	4.75 to 5.25	V
Logic input voltage	$V_{CS}, V_{DI}, V_{CLK}, V_{PWM}$	-0.3 to V_{VCC}	V
Serial interface clock frequency	f_{CLK}	2	MHz
PWM input frequency	f_{PWM}	max. 25	kHz
Junction temperature range	T_J	-40 to +150	°C

Note: 1. Threshold for undervoltage description

7. Noise and Surge Immunity

Parameters	Test Conditions	Value
Conducted interferences	ISO 7637-1	Level 4 ⁽¹⁾
Interference suppression	VDE 0879 Part 2	Level 5
ESD (Human Body Model)	ESD S 5.1	2kV
CDM (Charge Device Model)	ESD STM5.3.1	500V

Note: 1. Test pulse 5: $V_{smax} = 40V$

8. Electrical Characteristics

$7.5V < V_{VS} < 40V$; $4.75V < V_{VCC} < 5.25V$; INH = High; $-40^{\circ}C < T_j < 150^{\circ}C$; unless otherwise specified, all values refer to GND pins.

No.	Parameters	Test Conditions	Pin	Symbol	Min.	Typ.	Max.	Unit	Type*
1	Current Consumption								
1.1	Quiescent current VS	$V_{VS} < 20V$, SI = low	10, 11	I_{VS}		1	2	μA	A
1.2	Quiescent current VCC	$4.75V < V_{VCC} < 5.25V$, SI = low	9	I_{VCC}		60	100	μA	A
1.3	Supply current VS	$V_{VS} < 20V$ normal operating, all outputs off, input register bit 13 (OLD) = high	10, 11	I_{VS}		4	6	mA	A
1.4	Supply current VCC	$4.75V < V_{VCC} < 5.25V$, normal operating	9	I_{VCC}		350	650	μA	A
1.5	Discharge current VS	$V_{VS} = 32.5V$, INH = low	10, 11	I_{VS}	0.5		5.5	mA	A
1.6	Discharge current VS	$V_{VS} = 40V$, INH = low	10, 11	I_{VS}	2.5		14	mA	A
2	Undervoltage Detection, Power-on Reset								
2.1	Power-on reset threshold		9	V_{VCC}	3.2	3.9	4.4	V	A
2.2	Power-on reset delay time	After switching on V_{VCC}		t_{dPor}	30	95	190	μs	A
2.3	Undervoltage-detection threshold	$V_{VCC} = 5V$	10, 11	V_{UV}	5.6		7.0	V	A
2.4	Undervoltage-detection hysteresis	$V_{VCC} = 5V$	10, 11	ΔV_{UV}		0.6		V	A
2.5	Undervoltage-detection delay time			t_{dUV}	10		40	μs	A
3	Thermal Prewarning and Shutdown								
3.1	Thermal prewarning set			$T_{jPW\ set}$	120	145	170	$^{\circ}C$	B
3.2	Thermal prewarning reset			$T_{jPW\ reset}$	105	130	155	$^{\circ}C$	B
3.3	Thermal prewarning hysteresis			ΔT_{jPW}		15		K	B
3.4	Thermal shutdown off			$T_{j\ switch\ off}$	150	175	200	$^{\circ}C$	B
3.5	Thermal shutdown on			$T_{j\ switch\ on}$	135	160	185	$^{\circ}C$	B

*) Type means: A = 100% tested, B = 100% correlation tested, C = Characterized on samples, D = Design parameter

- Notes:
1. Delay time between rising edge of input signal at pin CS after data transmission and switch on/off output stages to 90% of final level. Device not in standby for $t > 1ms$.
 2. Delay time between rising/falling edge of input signal at pin PWM and switch on/off output stages to 90% of final level.
 3. Difference between switch-on and switch-off delay time of input signal at pin PWM to output stages in PWM mode.

8. Electrical Characteristics (Continued)

7.5V < V_{VS} < 40V; 4.75V < V_{VCC} < 5.25V; INH = High; -40°C < T_j < 150°C; unless otherwise specified, all values refer to GND pins.

No.	Parameters	Test Conditions	Pin	Symbol	Min.	Typ.	Max.	Unit	Type*
3.6	Thermal shutdown hysteresis			$\Delta T_{j \text{ switch off}}$		15		K	B
3.7	Ratio thermal shutdown off/thermal prewarning set			$\frac{T_{j \text{ switch off}}}{T_{j \text{ PW set}}}$	1.05	1.2			B
3.8	Ratio thermal shutdown on/thermal prewarning reset			$\frac{T_{j \text{ switch on}}}{T_{j \text{ PW reset}}}$	1.05	1.2			B
4	Output Specification (OUT1 to OUT3)								
4.1	On resistance	I _{Out1-3} = -0.9A	2, 12, 15	R _{DSon1-3H}			1.5	Ω	A
4.2		I _{Out1-3} = -0.9A	2, 12, 15	R _{DSon1-3L}			1.5	Ω	A
4.3	High-side output leakage current	V _{Out1-3H} = 0V, output stages off	2, 12, 15	I _{Out1-3H}	-15			μA	A
4.4	Low-side output leakage current	V _{Out1-3L} = V _{VS} , output stages off	2, 12, 15	I _{Out1-3L}			300	μA	A
4.5	High-side switch reverse diode forward voltage	I _{Out} = 1.5A	2, 12, 15	V _{Out1-3} - V _{VS}			2	V	A
4.6	Low-side switch reverse diode forward voltage	I _{Out1-3L} = -1.5A	2, 12, 15	V _{Out1-3L}	2			V	A
4.7	High-side overcurrent limitation and shutdown threshold	7.5V < V _{VS} < 20V	2, 12, 15	I _{Out1-3}	1.0	1.3	1.7	A	A
4.8	Low-side overcurrent limitation and shutdown threshold	7.5V < V _{VS} < 20V	2, 12, 15	I _{Out1-3}	-1.7	-1.3	-1.0	A	A
4.9	High-side overcurrent limitation and shutdown threshold	20V < V _{VS} < 40V	2, 12, 15	I _{Out1-3}	1.0	1.3	2.0	A	A
4.10	Low-side overcurrent limitation and shutdown threshold	20V < V _{VS} < 40V	2, 12, 15	I _{Out1-3}	-2.0	-1.3	-1.0	A	A
4.11	Overcurrent shutdown delay time			t _{dSd}	10		40	μs	A
4.12	High-side open load detection current	Input register bit 13 (OLD) = low, output off V _{VS} = 13V, V _{Out1-3} = 0V	2, 12, 15	I _{Out1-3H}	1	2.5	4	mA	A
4.12a	High-side open load detection threshold level	Input register bit 13 (OLD) = low, output off V _{VS} = 13V, I _{Out1-3} = 0mA	2, 12, 15	V _{Out1-3_OLd_HTh}	V _{VS} - 3.5V	V _{VS} - 2.5V	V _{VS} - 1V	V	A

*) Type means: A = 100% tested, B = 100% correlation tested, C = Characterized on samples, D = Design parameter

- Notes:
1. Delay time between rising edge of input signal at pin CS after data transmission and switch on/off output stages to 90% of final level. Device not in standby for t > 1ms.
 2. Delay time between rising/falling edge of input signal at pin PWM and switch on/off output stages to 90% of final level.
 3. Difference between switch-on and switch-off delay time of input signal at pin PWM to output stages in PWM mode.

8. Electrical Characteristics (Continued)

7.5V < V_{VS} < 40V; 4.75V < V_{VCC} < 5.25V; INH = High; -40°C < T_j < 150°C; unless otherwise specified, all values refer to GND pins.

No.	Parameters	Test Conditions	Pin	Symbol	Min.	Typ.	Max.	Unit	Type*
4.13	Low-side open load detection current	Input register bit 13 (OLD) = low, output off V _{VS} = 13V, V _{Out 1-3} = 13V	2, 12, 15	I _{Out1-3L}	-6	-9	-11	mA	A
4.13a	Low-side open load detection threshold level	Input register bit 13 (OLD) = low, output off V _{VS} = 13V, I _{Out1-3} = 0mA	2, 12, 15	V _{Out1-3_OLd_LTh}	0.5	1.5	2.5	V	A
4.14	Open load detection current ratio			I _{Out1-3L} /I _{Out1-3H}	2	3	4		
4.15	High-side output switch on delay ^{(1),(2)}	V _{VS} = 13V R _{Load} = 30Ω		t _{don}			20	μs	A
4.16	Low-side output switch on delay ^{(1),(2)}	V _{VS} = 13V R _{Load} = 30Ω		t _{don}			20	μs	A
4.17	High-side output switch off delay ^{(1),(2)}	V _{VS} = 13V R _{Load} = 30Ω		t _{doff}			20	μs	A
4.18	Low-side output switch off delay ^{(1),(2)}	V _{VS} = 13V R _{Load} = 30Ω		t _{doff}			3	μs	A
4.19	Dead time between corresponding high-side and low-side switches	V _{VS} = 13V R _{Load} = 30Ω		t _{don} - t _{doff}	1			μs	A
4.20	Δt _{dPWM} low-side switch ⁽³⁾	V _{VS} = 13V R _{Load} = 30Ω		Δt _{dPWM} = t _{don} - t _{doff}			20	μs	A
4.21	Δt _{dPWM} high-side switch ⁽³⁾	V _{VS} = 13V R _{Load} = 30Ω		Δt _{dPWM} = t _{don} - t _{doff}	-5		5	μs	A
5	Logic Inputs DI, CLK, CS, PWM								
5.1	Input voltage low-level threshold		3, 4, 5, 6	V _{IL}	0.3 × V _{VCC}			V	A
5.2	Input voltage high-level threshold		3, 4, 5, 6	V _{IH}			0.7 × V _{VCC}	V	A
5.3	Hysteresis of input voltage		3, 4, 5, 6	ΔV _I	50		700	mV	A
5.4	Pull-down current pins DI, CLK, PWM	V _{DI} , V _{CLK} , V _{PWM} = V _{VCC}	4, 5, 6	I _{PD}	10		65	μA	A
5.5	Pull-up current pin CS	V _{CS} = 0V	3	I _{PU}	-65		-10	μA	A

*) Type means: A = 100% tested, B = 100% correlation tested, C = Characterized on samples, D = Design parameter

- Notes:
1. Delay time between rising edge of input signal at pin CS after data transmission and switch on/off output stages to 90% of final level. Device not in standby for t > 1ms.
 2. Delay time between rising/falling edge of input signal at pin PWM and switch on/off output stages to 90% of final level.
 3. Difference between switch-on and switch-off delay time of input signal at pin PWM to output stages in PWM mode.



8. Electrical Characteristics (Continued)

7.5V < V_{VS} < 40V; 4.75V < V_{VCC} < 5.25V; INH = High; -40°C < T_j < 150°C; unless otherwise specified, all values refer to GND pins.

No.	Parameters	Test Conditions	Pin	Symbol	Min.	Typ.	Max.	Unit	Type*
6 Serial Interface – Logic Output DO									
6.1	Output-voltage low level	I _{DOL} = 2mA	7	V _{DOL}			0.4	V	A
6.2	Output-voltage high level	I _{DOL} = -2mA	7	V _{DOH}	V _{VCC} - 0.7V			V	A
6.3	Leakage current (tri-state)	V _{CS} = V _{VCC} 0V < V _{DO} < V _{VCC}	7	I _{DO}	-10		10	μA	A
7 Inhibit Input – Timing									
7.1	Delay time from standby to normal operation			t _{dINH}			100	μs	A

*) Type means: A = 100% tested, B = 100% correlation tested, C = Characterized on samples, D = Design parameter

- Notes:
1. Delay time between rising edge of input signal at pin CS after data transmission and switch on/off output stages to 90% of final level. Device not in standby for t > 1ms.
 2. Delay time between rising/falling edge of input signal at pin PWM and switch on/off output stages to 90% of final level.
 3. Difference between switch-on and switch-off delay time of input signal at pin PWM to output stages in PWM mode.

9. Serial Interface Timing

No.	Parameters	Test Conditions	Pin	Timing Chart No. ⁽¹⁾	Symbol	Min.	Typ.	Max.	Unit	Type*
8 Serial Interface Timing										
8.1	DO enable after CS falling edge	C _{DO} = 100pF	7	1	t _{ENDO}			200	ns	D
8.2	DO disable after CS rising edge	C _{DO} = 100pF	7	2	t _{DISDO}			200	ns	D
8.3	DO fall time	C _{DO} = 100pF	7	-	t _{DOF}			100	ns	D
8.4	DO rise time	C _{DO} = 100pF	7	-	t _{DOR}			100	ns	D
8.5	DO valid time	C _{DO} = 100pF	7	10	t _{DOVal}			200	ns	D
8.6	CS setup time		3	4	t _{CSsethl}	225			ns	D
8.7	CS setup time		3	8	t _{CSseth}	225			ns	D
8.8	CS high time		3	9	t _{CSH}	500			ns	D
8.9	CLK high time		5	5	t _{CLKh}	225			ns	D
8.10	CLK low time		5	6	t _{CLKl}	225			ns	D
8.11	CLK period time		5	-	t _{CLKp}	500			ns	D
8.12	CLK setup time		5	7	t _{CLKsethl}	225			ns	D
8.13	CLK setup time		5	3	t _{CLKseth}	225			ns	D
8.14	DI setup time		4	11	t _{Dlset}	40			ns	D
8.15	DI hold time		4	12	t _{DIHold}	40			ns	D

*) Type means: A = 100% tested, B = 100% correlation tested, C = Characterized on samples, D = Design parameter

Figure 9-1. Serial Interface Timing with Chart Number

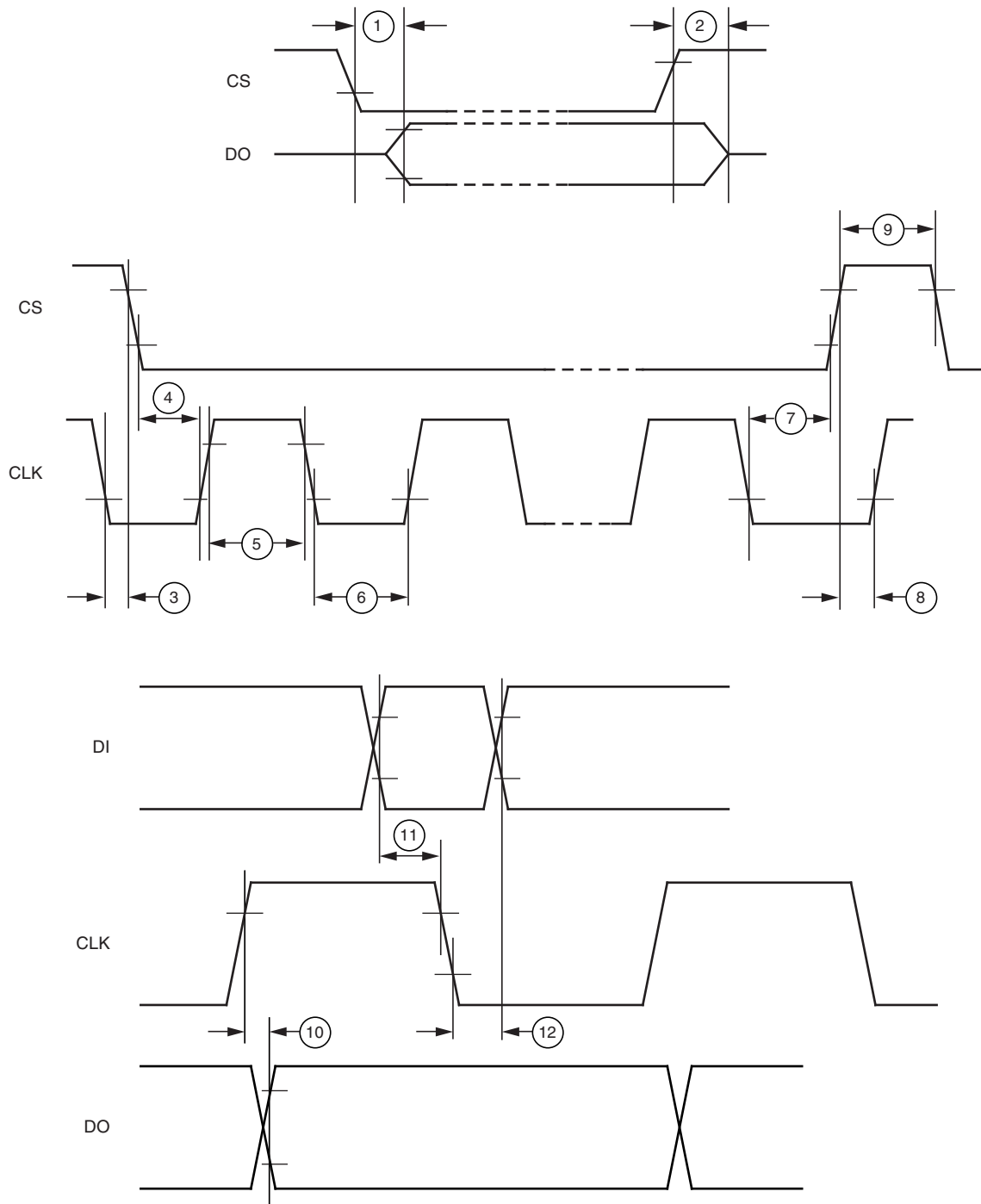

Inputs DI, CLK, CS: High level = $0.7 \times V_{CC}$, low level = $0.3 \times V_{CC}$
 Output DO: High level = $0.8 \times V_{CC}$, low level = $0.2 \times V_{CC}$

10. Application Circuit

Figure 10-1. Application Circuit

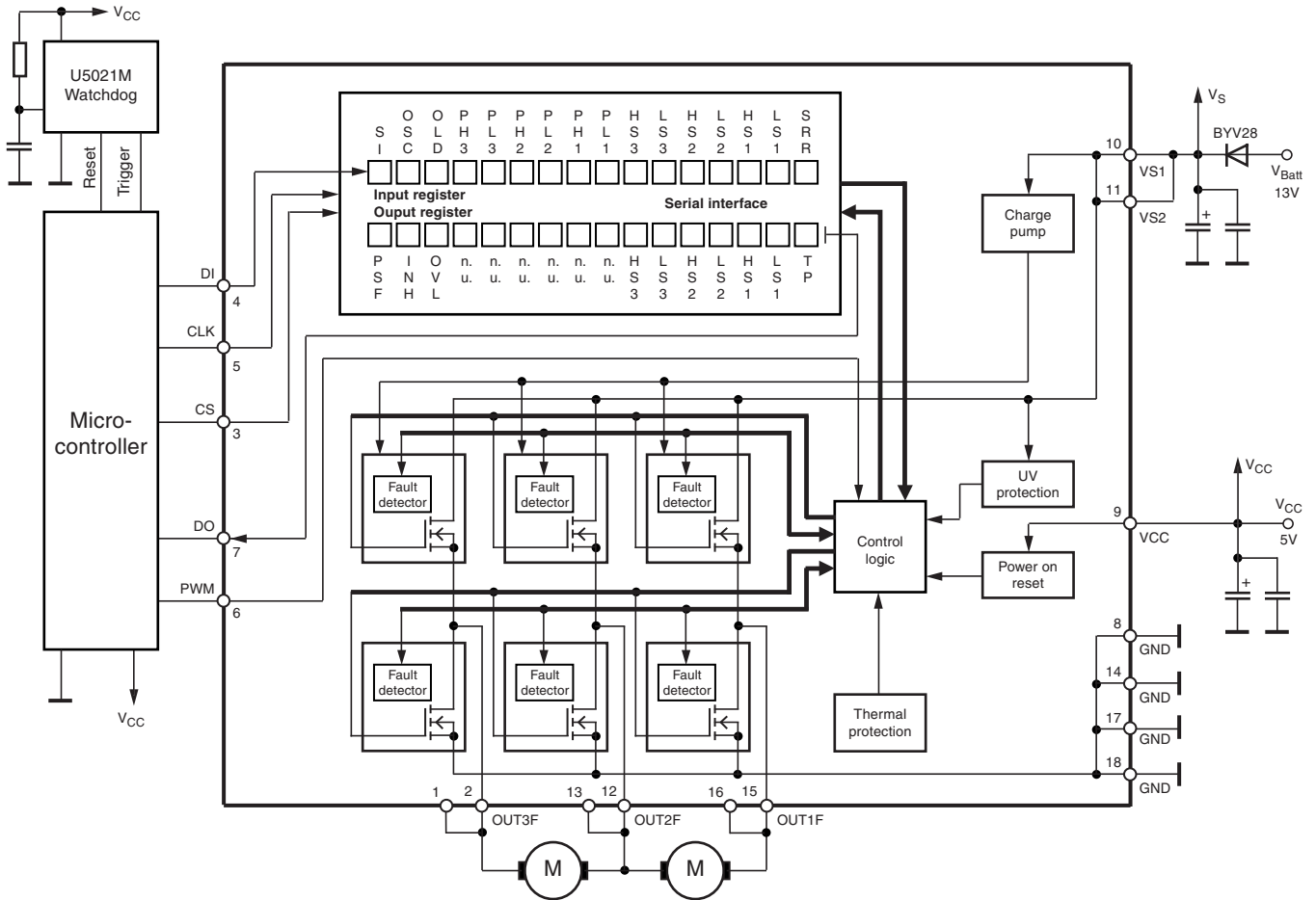

10.1 Application Notes

- Connect the blocking capacitors at V_{CC} and V_{VS} as close as possible to the power supply and GND pins.
- Recommended value for capacitors at V_{VS} :
 - Electrolytic capacitor $C > 22\mu\text{F}$ in parallel with a ceramic capacitor $C = 100\text{nF}$. The value for the electrolytic capacitor depends on external loads, conducted interferences, and the reverse conducting current $I_{\text{Out}1,2,3}$.
- Recommended value for capacitors at V_{CC} :
 - Electrolytic capacitor $C > 10\mu\text{F}$ in parallel with a ceramic capacitor $C = 100\text{nF}$.
- To reduce thermal resistance, place cooling areas on the PCB as close as possible to the GND pins and to the die pad.

11. Ordering Information

Extended Type Number	Package	Remarks
ATA6831C-PIQW	QFN18, 4mm × 4mm	Taped and reeled, Pb-free

12. Package Information

Top View

Side View

Bottom View

Z 10:1

technical drawings according to DIN specifications

Dimensions in mm
Not indicated tolerances ± 0.05

COMMON DIMENSIONS				
(Unit of Measure = mm)				
Symbol	MIN	NOM	MAX	NOTE
A	0.8	0.9	1	
A1	0.0	0.02	0.05	
A3	0.15	0.2	0.25	
D	3.95	4	4.05	
D2	2.65	2.7	2.75	
E	3.95	4	4.05	
E2	3.125	3.175	3.225	
L	0.3	0.4	0.5	
K	0.2	0.25	0.3	
b	0.16	0.23	0.3	
e		0.5 BSC		

05/20/11

Package Drawing Contact: packagedrawings@atmel.com	TITLE Package: VQFN_4x4_18L Exposed pad 2.7x3.175	DRAWING NO. 6.543-5133.01-4	REV. 3
--	--	---------------------------------------	------------------



13. Revision History

Please note that the following page numbers referred to in this section refer to the specific revision mentioned, not to this document.

Revision No.	History
9215C-AUTO-06/11	<ul style="list-style-type: none">• Package Information: drawing changed
9215B-AUTO-01/11	<ul style="list-style-type: none">• Features on page 1 changed• Section 3.6 "Inhibit" on page 7 changed• Section 8 "Electrical Characteristics" number 1.1 on page 9 changed



Atmel Corporation

2325 Orchard Parkway
San Jose, CA 95131
USA

Tel: (+1)(408) 441-0311

Fax: (+1)(408) 487-2600

Atmel Asia Limited

Unit 01-5 & 16, 19/F
BEA Tower, Millennium City 5
418 Kwun Tong Road
Kwun Tong, Kowloon
HONG KONG

Tel: (+852) 2245-6100

Fax: (+852) 2722-1369

Atmel Munich GmbH

Business Campus
Parking 4
D-85748 Garching b. Munich
GERMANY

Tel: (+49) 89-31970-0

Fax: (+49) 89-3194621

Atmel Japan

9F, Tonetsu Shinkawa Bldg.
1-24-8 Shinkawa
Chuo-ku, Tokyo 104-0033
JAPAN

Tel: (+81) (3) 3523-3551

Fax: (+81) (3) 3523-7581

© 2011 Atmel Corporation. All rights reserved. / Rev.: 9215C-AUTO-06/11

Atmel®, Atmel logo and combinations thereof, and others are registered trademarks or trademarks of Atmel Corporation or its subsidiaries. Other terms and product names may be trademarks of others.

Disclaimer: The information in this document is provided in connection with Atmel products. No license, express or implied, by estoppel or otherwise, to any intellectual property right is granted by this document or in connection with the sale of Atmel products. EXCEPT AS SET FORTH IN THE ATMEL TERMS AND CONDITIONS OF SALES LOCATED ON THE ATMEL WEBSITE, ATMEL ASSUMES NO LIABILITY WHATSOEVER AND DISCLAIMS ANY EXPRESS, IMPLIED OR STATUTORY WARRANTY RELATING TO ITS PRODUCTS INCLUDING, BUT NOT LIMITED TO, THE IMPLIED WARRANTY OF MERCHANTABILITY, FITNESS FOR A PARTICULAR PURPOSE, OR NON-INFRINGEMENT. IN NO EVENT SHALL ATMEL BE LIABLE FOR ANY DIRECT, INDIRECT, CONSEQUENTIAL, PUNITIVE, SPECIAL OR INCIDENTAL DAMAGES (INCLUDING, WITHOUT LIMITATION, DAMAGES FOR LOSS AND PROFITS, BUSINESS INTERRUPTION, OR LOSS OF INFORMATION) ARISING OUT OF THE USE OR INABILITY TO USE THIS DOCUMENT, EVEN IF ATMEL HAS BEEN ADVISED OF THE POSSIBILITY OF SUCH DAMAGES. Atmel makes no representations or warranties with respect to the accuracy or completeness of the contents of this document and reserves the right to make changes to specifications and products descriptions at any time without notice. Atmel does not make any commitment to update the information contained herein. Unless specifically provided otherwise, Atmel products are not suitable for, and shall not be used in, automotive applications. Atmel products are not intended, authorized, or warranted for use as components in applications intended to support or sustain life.

Looking for pricing, stock, or lifecycle information?

Click below to explore more details on WIN SOURCE:

- ⊖ [View ATA6831C-PIQW](#) on WIN SOURCE
- ⊖ [Microchip Technology](#) Information

Optimize Your Supply Chain with WIN SOURCE Solutions

- ✓ Global Sourcing Solution
- ✓ Obsolete Management
- ✓ Cost Control Management
- ✓ Shortage Management
- ✓ Alternative Solution
- ✓ Excess Inventory Management