



## DUAL SUPPLY, LOW ON-STATE RESISTANCE SPST CMOS ANALOG SWITCHES

### FEATURES

- $\pm 1$ -V to  $\pm 6$ -V Dual-Supply Operation
- Specified ON-State Resistance:
  - 25  $\Omega$  Max With  $\pm 5$ -V Supply
  - 35  $\Omega$  Max With  $\pm 3.3$ -V Supply
  - 47  $\Omega$  Max With  $\pm 1.8$ -V Supply
- Specified Low OFF-Leakage Currents:
  - 5 nA at 25°C
  - 10 nA at 85°C
- Specified Low ON-Leakage Currents:
  - 5 nA at 25°C
  - 10 nA at 85°C
- Low Charge Injection: 13 pC ( $\pm 5$ -V Supply)
- Fast Switching Speed:
  - $t_{ON} = 85$  ns,  $t_{OFF} = 50$  ns ( $\pm 5$ -V Supply)
- Break-Before-Make Operation ( $t_{ON} > t_{OFF}$ )
- Latch-Up Performance Exceeds 100 mA Per JESD 78, Class II
- ESD Performance Tested Per JESD 22
  - 2500-V Human-Body Model (A114-F)
  - 1000-V Charged-Device Model (C101-C)
  - 250-V Machine Model (A115-A)

### DESCRIPTION/ORDERING INFORMATION

The TS12A4516/TS12A4517 are single pole/single throw (SPST), low-voltage, dual-supply CMOS analog switches, with very low switch ON-state resistance. The TS12A4516 is normally open (NO). The TS12A4517 is normally closed (NC).

These CMOS switches can operate continuously with a dual supplies between  $\pm 1$  V and  $\pm 6$  V [ $2$  V  $< (V_+ - V_-) < 12$  V]. Each switch can handle rail-to-rail analog signals. The OFF-leakage current maximum is only 5 nA at 25°C or 10 nA at 85°C.

For pin-compatible parts for use with single supply, see the TS12A4514/TS12A4515.

### ORDERING INFORMATION

$T_A$	PACKAGE <sup>(1)(2)</sup>		ORDERABLE PART NUMBER	TOP-SIDE MARKING
–40°C to 85°C	SOIC – D	Reel of 1500	TS12A4516D	YD516
		Reel of 2500	TS12A4516DR	
	SOP (SOT-23) – DBV	Reel of 3000	TS12A4516DBVR	9CL_
	SOIC – D	Reel of 1500	TS12A4517D	YD517
		Reel of 2500	TS12A4517DR	
	SOP (SOT-23) – DBV	Reel of 3000	TS12A4517DBVR	9CM_

(1) Package drawings, standard packing quantities, thermal data, symbolization, and PCB design guidelines are available at [www.ti.com/sc/package](http://www.ti.com/sc/package).

(2) For the most current package and ordering information, see the Package Option Addendum at the end of this document, or see the TI website at [www.ti.com](http://www.ti.com).



Please be aware that an important notice concerning availability, standard warranty, and use in critical applications of Texas Instruments semiconductor products and disclaimers thereto appears at the end of this data sheet.

**PIN CONFIGURATIONS**

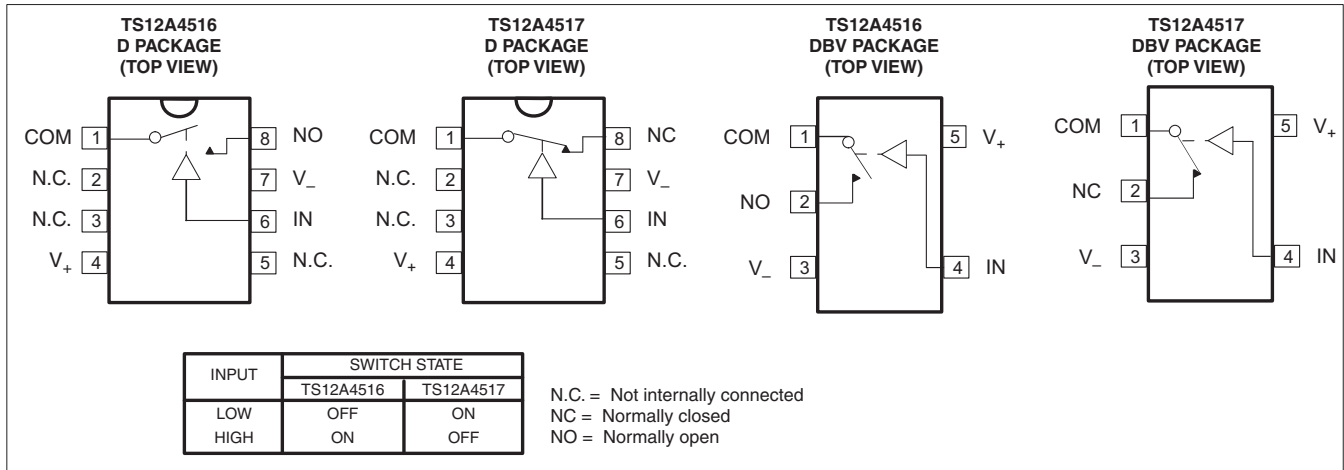

**Absolute Minimum and Maximum Ratings<sup>(1)(2)</sup>**

voltages referenced to 0 V

		MIN	MAX	UNIT
$V_+$	Supply voltage range	-0.3	13	V
$V_{NC}$ $V_{NO}$ $V_{COM}$	Analog voltage range <sup>(3)</sup>	$V_- - 0.3$	$V_+ + 0.3$	V
$V_{IN}$	Logic input range	$V_- - 0.3$	$V_+ + 0.3$	V
	Continuous current into any terminal		±20	mA
	Peak current, NO or COM (pulsed at 1 ms, 10% duty cycle)		±30	mA
	ESD per method 3015.7		>2000	V
	Continuous power dissipation ( $T_A = 70^\circ\text{C}$ )	8-pin SOIC (derate 5.88 mW/°C above 70°C)		471
		5-pin SOT23-5 (derate 7.1 mW/°C above 70°C)		571
$T_A$	Operating temperature range	-40	85	°C
$T_{stg}$	Storage temperature range	-65	150	°C
	Lead temperature (soldering, 10 s)		300	°C

- (1) Stresses beyond those listed under "absolute maximum ratings" may cause permanent damage to the device. These are stress ratings only, and functional operation of the device at these or any other conditions beyond those indicated under "recommended operating conditions" is not implied. Exposure to absolute-maximum-rated conditions for extended periods may affect device reliability.
- (2) The algebraic convention, whereby the most negative value is a minimum and the most positive value is a maximum
- (3) Voltages exceeding  $V_+$  or GND on any signal terminal are clamped by internal diodes. Limit forward-diode current to maximum current rating.

**Electrical Characteristics for ±5-V Supply<sup>(1)</sup>**
 $V_+ = 4.5\text{ V to }5.5\text{ V}$ ,  $V_- = -4.5\text{ V to }-5.5\text{ V}$ ,  $T_A = -40^\circ\text{C to }85^\circ\text{C}$  (unless otherwise noted)

PARAMETER	SYMBOL	TEST CONDITIONS	$T_A$	MIN	TYP <sup>(2)</sup>	MAX	UNIT
<b>Analog Switch</b>							
Analog signal range	$V_{COM}, V_{NO}, V_{NC}$			$V_-$		$V_+$	V
ON-state resistance	$r_{on}$	$V_+ = 4.5\text{ V}, V_- = -4.5\text{ V},$ $V_{COM} = 3.5\text{ V},$ $I_{COM} = 20\text{ mA}$	25°C		12	20	Ω
			Full			25	
ON-state resistance flatness	$r_{on(Flat)}$	$V_+ = 4.5\text{ V}, V_- = -4.5\text{ V},$ $V_{COM} = -3.5\text{ V}, 0\text{ V}, 3.5\text{ V},$ $I_{COM} = 20\text{ mA}$	25°C		1.2	2.5	Ω
			Full			3	
NO, NC OFF leakage current <sup>(3)</sup>	$I_{NO(OFF)},$ $I_{NC(OFF)}$	$V_+ = 5.5\text{ V}, V_- = -5.5\text{ V},$ $V_{COM} = 4.5\text{ V},$ $V_{NO}\text{ or }V_{NC} = -4.5\text{ V}$	25°C			5	nA
			Full			10	
COM OFF leakage current <sup>(3)</sup>	$I_{COM(OFF)}$	$V_+ = 5.5\text{ V}, V_- = -5.5\text{ V},$ $V_{COM} = -4.5\text{ V},$ $V_{NO}\text{ or }V_{NC} = 4.5\text{ V}$	25°C			5	nA
			Full			10	
COM ON leakage current <sup>(3)</sup>	$I_{COM(ON)}$	$V_+ = 5.5\text{ V}, V_- = -5.5\text{ V},$ $V_{COM} = 5.5\text{ V},$ $V_{NO}\text{ or }V_{NC} = \text{open}$	25°C			5	nA
			Full			10	
<b>Digital Control Input (IN)</b>							
Input logic high	$V_{IH}$		Full	$V_+ - 1.5$			V
Input logic low	$V_{IL}$		Full	$V_-$		$V_+ - 3.5$	V
Input leakage current	$I_{IH}, I_{IL}$	$V_{IN} = V_+, 0\text{ V}$	Full			0.010	μA
<b>Dynamic</b>							
Turn-on time	$t_{ON}$	See <a href="#">Figure 2</a>	25°C		58	75	ns
			Full			85	
Turn-off time	$t_{OFF}$	See <a href="#">Figure 2</a>	25°C		28	45	ns
			Full			50	
Charge injection <sup>(4)</sup>	$Q_C$	$C_L = 1\text{ nF}, V_{NO} = 0\text{ V},$ $R_S = 0\text{ Ω},$ See <a href="#">Figure 1</a>	25°C		-13		pC
NO, NC OFF capacitance	$C_{NO(OFF)},$ $C_{NC(OFF)}$	$f = 1\text{ MHz},$ See <a href="#">Figure 4</a>	25°C		5.5		pF
COM OFF capacitance	$C_{COM(OFF)}$	$f = 1\text{ MHz},$ See <a href="#">Figure 4</a>	25°C		5.5		pF
COM ON capacitance	$C_{COM(ON)}$	$f = 1\text{ MHz},$ See <a href="#">Figure 4</a>	25°C		16		pF
Digital input capacitance	$C_I$	$V_{IN} = V_+, 0\text{ V}$	25°C		1.5		pF
Bandwidth	BW	$R_L = 50\text{ Ω}, C_L = 15\text{ pF},$ $V_{NO} = 1\text{ V}_{RMS}, f = 100\text{ kHz}$	25°C		464		MHz
OFF isolation	$O_{ISO}$	$R_L = 50\text{ Ω}, C_L = 15\text{ pF},$ $V_{NO} = 1\text{ V}_{RMS}, f = 1\text{ MHz}$	25°C		-83		dB
Total harmonic distortion	THD	$R_L = 600\text{ Ω}, C_L = 15\text{ pF},$ $V_{NO} = 1\text{ V}_{RMS}, f = 20\text{ kHz}$	25°C		0.07		%
<b>Supply</b>							
$V_+$ supply current	$I_+$	$V_{IN} = 0\text{ V or }V_+$	25°C			70	μA
			Full			80	
$V_-$ supply current	$I_-$	$V_{IN} = 0\text{ V or }V_+$	25°C		-70		μA
			Full		-80		

- (1) The algebraic convention, whereby the most negative value is a minimum and the most positive value is a maximum.  
 (2) Typical values are at  $T_A = 25^\circ\text{C}$ .  
 (3) Leakage parameters are 100% tested at maximum-rated hot operating temperature, and are ensured by correlation at  $25^\circ\text{C}$ .  
 (4) Specified by design, not production tested

## Electrical Characteristics for $\pm 3.3\text{-V}$ Supply<sup>(1)</sup>

$V_+ = 3.0\text{ V to } 3.6\text{ V}$ ,  $V_- = -3.0\text{ V to } -3.6$ ,  $T_A = -40^\circ\text{C to } 85^\circ\text{C}$  (unless otherwise noted)

PARAMETER	SYMBOL	TEST CONDITIONS	$T_A$	MIN	TYP <sup>(2)</sup>	MAX	UNIT
<b>Analog Switch</b>							
Analog signal range	$V_{\text{COM}}, V_{\text{NO}}, V_{\text{NC}}$			$V_-$		$V_+$	V
ON-state resistance	$r_{\text{on}}$	$V_+ = 3.0\text{ V}, V_- = -3.0\text{ V},$ $V_{\text{COM}} = 3\text{ V},$ $I_{\text{COM}} = 20\text{ mA}$	25°C		17	25	$\Omega$
			Full			35	
ON-state resistance flatness	$r_{\text{on(flat)}}$	$V_{\text{COM}} = -2\text{ V}, 0\text{ V}, 2\text{ V},$ $I_{\text{COM}} = 20\text{ mA}$	25°C		1.5	3	$\Omega$
			Full			4	
NO, NC OFF leakage current <sup>(3)</sup>	$I_{\text{NO(OFF)}},$ $I_{\text{NC(OFF)}}$	$V_+ = 3.6\text{ V}, V_- = -3.6\text{ V},$ $V_{\text{COM}} = 3\text{ V},$ $V_{\text{NO}} \text{ or } V_{\text{NC}} = -3\text{ V}$	25°C			5	nA
			Full			10	
COM OFF leakage current <sup>(3)</sup>	$I_{\text{COM(OFF)}}$	$V_+ = 3.6\text{ V}, V_- = -3.6\text{ V},$ $V_{\text{COM}} = -3\text{ V},$ $V_{\text{NO}} \text{ or } V_{\text{NC}} = 3\text{ V}$	25°C			5	nA
			Full			10	
COM ON leakage current <sup>(3)</sup>	$I_{\text{COM(ON)}}$	$V_+ = 3.6\text{ V}, V_- = -3.6\text{ V},$ $V_{\text{COM}} = 3.6\text{ V},$ $V_{\text{NO}} \text{ or } V_{\text{NC}} = \text{open}$	25°C			5	nA
			Full			10	
<b>Digital Control Input (IN)</b>							
Input logic high	$V_{\text{IH}}$		Full	$V_+ - 1.5$			V
Input logic low	$V_{\text{IL}}$		Full	$V_-$		$V_+ - 3.5$	V
Input leakage current	$I_{\text{IH}}, I_{\text{IL}}$	$V_{\text{IN}} = V_+, 0\text{ V}$	Full			0.01	$\mu\text{A}$
<b>Dynamic</b>							
Turn-on time	$t_{\text{ON}}$	see <a href="#">Figure 2</a>	25°C		65	85	ns
			Full			95	
Turn-off time	$t_{\text{OFF}}$	see <a href="#">Figure 2</a>	25°C		37	60	ns
			Full			70	
Charge injection <sup>(4)</sup>	$Q_{\text{C}}$	$C_{\text{L}} = 1\text{ nF}, V_{\text{NO}} = 0\text{ V},$ $R_{\text{S}} = 0\ \Omega$ , See <a href="#">Figure 1</a>	25°C		-7.5		pC
NO, NC OFF capacitance	$C_{\text{NO(OFF)}},$ $C_{\text{NC(OFF)}}$	$f = 1\text{ MHz}$ , See <a href="#">Figure 4</a>	25°C		5.5		pF
COM OFF capacitance	$C_{\text{COM(OFF)}}$	$f = 1\text{ MHz}$ , See <a href="#">Figure 4</a>	25°C		5.5		pF
COM ON capacitance	$C_{\text{COM(ON)}}$	$f = 1\text{ MHz}$ , See <a href="#">Figure 4</a>	25°C		16		pF
Digital input capacitance	$C_{\text{I}}$	$V_{\text{IN}} = V_+, 0\text{ V}$	25°C		1.5		pF
Bandwidth	BW	$R_{\text{L}} = 50\ \Omega, C_{\text{L}} = 15\text{ pF},$ $V_{\text{NO}} = 1\text{ V}_{\text{RMS}}, f = 100\text{ kHz}$	25°C		464		MHz
OFF isolation	$O_{\text{ISO}}$	$R_{\text{L}} = 50\ \Omega, C_{\text{L}} = 15\text{ pF},$ $V_{\text{NO}} = 1\text{ V}_{\text{RMS}}, f = 100\text{ kHz}$	25°C		-83		dB
Total harmonic distortion	THD	$R_{\text{L}} = 600\ \Omega, C_{\text{L}} = 15\text{ pF},$ $V_{\text{NO}} = 1\text{ V}_{\text{RMS}}, f = 20\text{ kHz}$	25°C		0.10		%
<b>Supply</b>							
$V_+$ supply current	$I_+$	$V_{\text{IN}} = 0\text{ V or } V_+$	25°C			40	$\mu\text{A}$
			Full			45	
$V_-$ supply current	$I_-$	$V_{\text{IN}} = 0\text{ V or } V_+$	25°C		-40		$\mu\text{A}$
			Full		45		

(1) The algebraic convention, whereby the most negative value is a minimum and the most positive value is a maximum.

(2) Typical values are at  $T_A = 25^\circ\text{C}$ .

(3) Leakage parameters are 100% tested at maximum-rated hot operating temperature, and are ensured by correlation at  $25^\circ\text{C}$ .

(4) Specified by design, not production tested

**Electrical Characteristics for ±1.8-V Supply<sup>(1)</sup>**
 $V_+ = 1.65\text{ V to }1.95\text{ V}$ ,  $V_- = -1.65\text{ V to }-1.95\text{ V}$ ,  $T_A = -40^\circ\text{C to }85^\circ\text{C}$  (unless otherwise noted)

PARAMETER	SYMBOL	TEST CONDITIONS	$T_A$	MIN	TYP <sup>(2)</sup>	MAX	UNIT
<b>Analog Switch</b>							
Analog signal range	$V_{\text{COM}}, V_{\text{NO}}, V_{\text{NC}}$			$V_-$		$V_+$	V
ON-state resistance	$r_{\text{on}}$	$V_+ = 1.65\text{ V}, V_- = -1.65\text{ V},$ $V_{\text{COM}} = 0\text{ V},$ $I_{\text{COM}} = 20\text{ mA}$	25°C		28	40	$\Omega$
			Full			47	
ON-state resistance flatness	$r_{\text{on(Flat)}}$	$V_+ = 1.65\text{ V}, V_- = -1.65\text{ V},$ $V_{\text{COM}} = -1.8\text{ V}, 0\text{ V}, 1.5\text{ V},$ $I_{\text{COM}} = 20\text{ mA}$	25°C		9	13	$\Omega$
			Full			15	
NO, NC OFF leakage current <sup>(3)</sup>	$I_{\text{NO(OFF)}},$ $I_{\text{NC(OFF)}}$	$V_+ = 1.95\text{ V}, V_- = -1.95\text{ V},$ $V_{\text{COM}} = 1.65\text{ V},$ $V_{\text{NO}} \text{ or } V_{\text{NC}} = -1.65\text{ V}$	25°C			5	nA
			Full			10	
COM OFF leakage current <sup>(3)</sup>	$I_{\text{COM(OFF)}}$	$V_+ = 1.95\text{ V}, V_- = -1.95\text{ V},$ $V_{\text{COM}} = -1.65\text{ V},$ $V_{\text{NO}} \text{ or } V_{\text{NC}} = 1.65\text{ V}$	25°C			5	nA
			Full			10	
COM ON leakage current <sup>(3)</sup>	$I_{\text{COM(ON)}}$	$V_+ = 1.95\text{ V}, V_- = -1.95\text{ V},$ $V_{\text{COM}} = 1.95\text{ V},$ $V_{\text{NO}} \text{ or } V_{\text{NC}} = \text{open}$	25°C			5	nA
			Full			10	
<b>Digital Control Input (IN)</b>							
Input logic high	$V_{\text{IH}}$		Full	$V_+ - 1.5$			V
Input logic low	$V_{\text{IL}}$		Full	$V_-$		$V_+ - 3.5$	V
Input leakage current	$I_{\text{IH}}, I_{\text{IL}}$	$V_{\text{IN}} = V_+, 0\text{ V}$	Full			0.01	$\mu\text{A}$
<b>Dynamic</b>							
Turn-on time <sup>(4)</sup>	$t_{\text{ON}}$	See <a href="#">Figure 2</a>	25°C		90	120	ns
			Full			150	
Turn-off time <sup>(4)</sup>	$t_{\text{OFF}}$	See <a href="#">Figure 2</a>	25°C		95	150	ns
			Full			200	
Charge injection <sup>(4)</sup>	$Q_C$	$C_L = 1\text{ nF}$ , See <a href="#">Figure 1</a>	25°C		-3.5		pC
NO, NC OFF capacitance	$C_{\text{NO(OFF)}},$ $C_{\text{NC(OFF)}}$	$f = 1\text{ MHz}$ , See <a href="#">Figure 4</a>	25°C		6		pF
COM OFF capacitance	$C_{\text{COM(OFF)}}$	$f = 1\text{ MHz}$ , See <a href="#">Figure 4</a>	25°C		6		pF
COM ON capacitance	$C_{\text{COM(ON)}}$	$f = 1\text{ MHz}$ , See <a href="#">Figure 4</a>	25°C		14.5		pF
Digital input capacitance	$C_I$	$V_{\text{IN}} = V_+, 0\text{ V}$	25°C		1.5		pF
Bandwidth	BW	$R_L = 50\ \Omega, C_L = 15\text{ pF},$ $V_{\text{NO}} = 1\text{ V}_{\text{RMS}}, f = 100\text{ kHz}$	25°C		464		MHz
OFF isolation	$O_{\text{ISO}}$	$R_L = 50\ \Omega, C_L = 15\text{ pF},$ $V_{\text{NO}} = 1\text{ V}_{\text{RMS}}, f = 1\text{ MHz}$	25°C		-83		dB
Total harmonic distortion	THD	$R_L = 600\ \Omega, C_L = 50\text{ pF},$ $V_{\text{NO}} = 1\text{ V}_{\text{RMS}}, f = 20\text{ kHz}$	25°C		0.37		%
<b>Supply</b>							
$V_+$ supply current	$I_+$	$V_{\text{IN}} = 0\text{ V or }V_+$	25°C			20	$\mu\text{A}$
			Full			30	
$V_-$ supply current	$I_-$	$V_{\text{IN}} = 0\text{ V or }V_+$	25°C		-20		$\mu\text{A}$
			Full		-30		

- (1) The algebraic convention, whereby the most negative value is a minimum and the most positive value is a maximum.  
 (2) Typical values are at  $T_A = 25^\circ\text{C}$ .  
 (3) Leakage parameters are 100% tested at maximum-rated hot operating temperature, and are ensured by correlation at 25°C.  
 (4) Specified by design, not production tested

**PIN DESCRIPTION<sup>(1)</sup>**

PIN NO.				NAME	DESCRIPTION
TS12A4516		TS12A4517			
D, P	SOT23-5	D, P	SOT23-5		
1	1	1	1	COM	Common
2, 3, 5	–	2, 3, 5	–	N.C.	No connect (not internally connected)
4	5	4	5	V <sub>+</sub>	Positive power supply
6	4	6	4	IN	Digital control to connect COM to NO or NC
7	3	7	3	V <sub>-</sub>	Negative power supply
8	2	–	–	NO	Normally open
–	–	8	2	NC	Normally closed

(1) NO, NC, and COM pins are identical and interchangeable. Any may be considered as an input or an output; signals pass in both directions.

## APPLICATION INFORMATION

### Power-Supply Considerations

The TS12A4516 and TS12A4517 operate with power-supply voltages from  $\pm 1$  V to  $\pm 6$  V [ $(2 \text{ V} < (V_+ - V_-) < 12 \text{ V})$ ], but are tested and specified at  $\pm 5$ V,  $\pm 3.3$ V, and  $\pm 1.8$ V supplies. The pin-compatible TS12A4514 and TS12A4515 are recommended for use when only a single supply is desirable.

The TS12A4516 and TS12A4517 construction is typical of most CMOS analog switches, except that they have only two supply pins:  $V_+$  and  $V_-$ .  $V_+$  and  $V_-$  drive the internal CMOS switches and set their analog voltage limits. Reverse ESD-protection diodes are internally connected between each analog-signal pin and both  $V_+$  and  $V_-$ . One of these diodes conducts if any analog signal exceeds  $V_+$  or  $V_-$ .

Virtually all the analog leakage current comes from the ESD diodes to  $V_+$  or  $V_-$ . Although the ESD diodes on a given signal pin are identical and, therefore, fairly well balanced, they are reverse biased differently. Each is biased by either  $V_+$  or  $V_-$  and the analog signal. This means their leakages will vary as the signal varies. The difference in the two diode leakages to the  $V_+$  and  $V_-$  pins constitutes the analog-signal-path leakage current. All analog leakage current flows between each pin and one of the supply terminals, not to the other switch terminal. This is why both sides of a given switch can show leakage currents of the same or opposite polarity.

$V_+$  and  $V_-$  also power the internal logic and logic-level translators. The logic-level translators convert the logic levels to switched  $V_+$  and  $V_-$  signals to drive the analog signal gates.

### Logic-Level Thresholds

Since these parts have no ground pin, the logic-level threshold is referenced to  $V_+$ . The threshold limits are  $V_+ - 1.5$  V and  $V_+ - 3.5$  V for  $V_+$  levels between 6 V and 3 V. When  $V_+ = 2$  V, the logic threshold is approximately 0.6 V.

#### CAUTION:

**Do not connect the TS12A4516/TS12A4517  $V_+$  to 3 V and then connect the logic-level pins to logic-level signals that operate from 5-V supply. TTL levels can exceed 3 V and violate the absolute maximum ratings, damaging the part and/or external circuits.**

### Test Circuits/Timing Diagrams

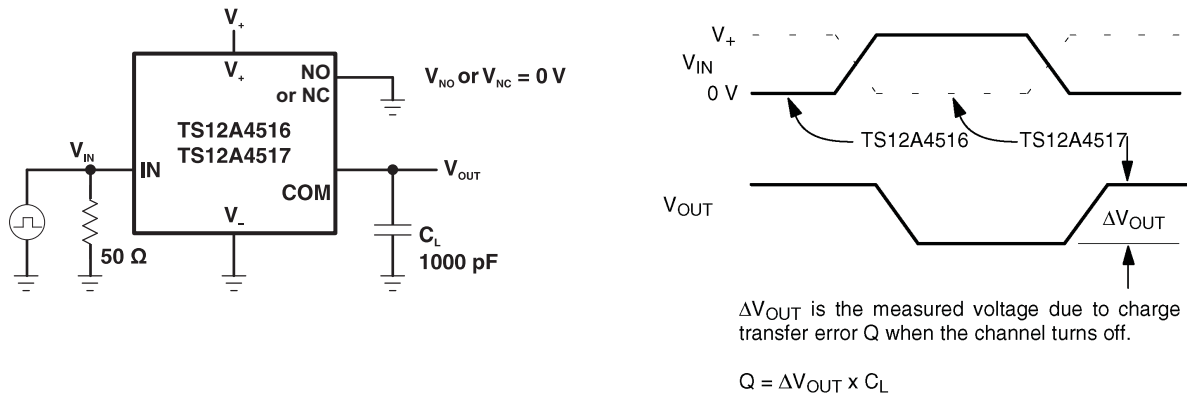

**Figure 1. Charge Injection**

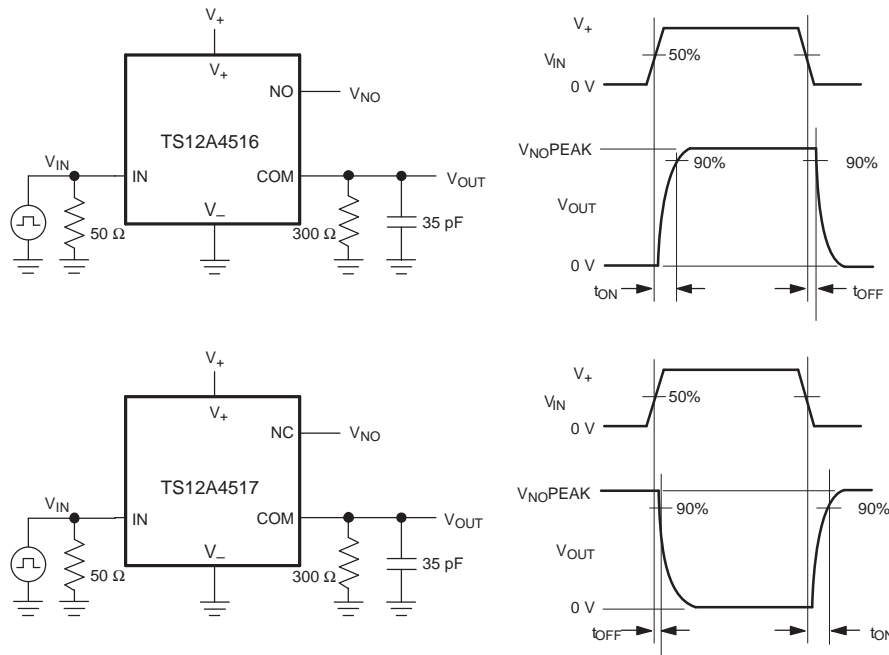
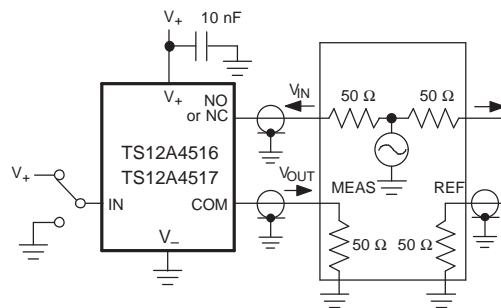

Figure 2. Switching Times



Measurements are standardized against short at socket terminals. OFF isolation is measured between COM and OFF terminals on each switch. ON loss is measured between COM and ON terminals on each switch. Signal direction through switch is reversed; worst values are recorded.

$$\text{OFF Isolation} = 20 \log \frac{V_{OUT}}{V_{IN}}$$

$$\text{ON Loss} = 20 \log \frac{V_{OUT}}{V_{IN}}$$

Figure 3. OFF Isolation and ON Loss

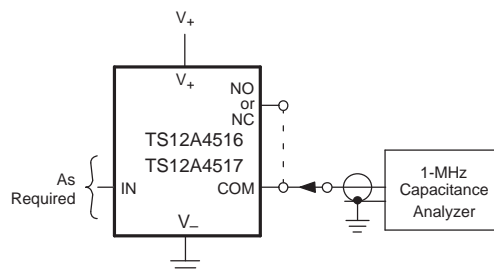

Figure 4. NO, NC, and COM Capacitance

**PACKAGING INFORMATION**

Orderable Device	Status (1)	Package Type	Package Drawing	Pins	Package Qty	Eco Plan (2)	Lead/Ball Finish (6)	MSL Peak Temp (3)	Op Temp (°C)	Device Marking (4/5)	Samples
TS12A4516D	ACTIVE	SOIC	D	8	75	Green (RoHS & no Sb/Br)	CU NIPDAU	Level-1-260C-UNLIM	-40 to 85	YD516	<a href="#">Samples</a>
TS12A4516DBVR	ACTIVE	SOT-23	DBV	5	3000	Green (RoHS & no Sb/Br)	CU NIPDAU	Level-1-260C-UNLIM	-40 to 85	(9CLA, 9CLM)	<a href="#">Samples</a>
TS12A4516DR	ACTIVE	SOIC	D	8	2500	Green (RoHS & no Sb/Br)	CU NIPDAU	Level-1-260C-UNLIM	-40 to 85	YD516	<a href="#">Samples</a>
TS12A4517D	ACTIVE	SOIC	D	8	75	Green (RoHS & no Sb/Br)	CU NIPDAU	Level-1-260C-UNLIM	-40 to 85	YD517	<a href="#">Samples</a>
TS12A4517DBVR	ACTIVE	SOT-23	DBV	5	3000	Green (RoHS & no Sb/Br)	CU NIPDAU	Level-1-260C-UNLIM	-40 to 85	(9CMA, 9CMM)	<a href="#">Samples</a>
TS12A4517DR	ACTIVE	SOIC	D	8	2500	Green (RoHS & no Sb/Br)	CU NIPDAU	Level-1-260C-UNLIM	-40 to 85	YD517	<a href="#">Samples</a>
TS12A4517DRG4	ACTIVE	SOIC	D	8	2500	Green (RoHS & no Sb/Br)	CU NIPDAU	Level-1-260C-UNLIM	-40 to 85	YD517	<a href="#">Samples</a>

(1) The marketing status values are defined as follows:

**ACTIVE:** Product device recommended for new designs.

**LIFEBUY:** TI has announced that the device will be discontinued, and a lifetime-buy period is in effect.

**NRND:** Not recommended for new designs. Device is in production to support existing customers, but TI does not recommend using this part in a new design.

**PREVIEW:** Device has been announced but is not in production. Samples may or may not be available.

**OBSOLETE:** TI has discontinued the production of the device.

(2) **RoHS:** TI defines "RoHS" to mean semiconductor products that are compliant with the current EU RoHS requirements for all 10 RoHS substances, including the requirement that RoHS substance do not exceed 0.1% by weight in homogeneous materials. Where designed to be soldered at high temperatures, "RoHS" products are suitable for use in specified lead-free processes. TI may reference these types of products as "Pb-Free".

**RoHS Exempt:** TI defines "RoHS Exempt" to mean products that contain lead but are compliant with EU RoHS pursuant to a specific EU RoHS exemption.

**Green:** TI defines "Green" to mean the content of Chlorine (Cl) and Bromine (Br) based flame retardants meet JS709B low halogen requirements of <=100ppm threshold. Antimony trioxide based flame retardants must also meet the <=1000ppm threshold requirement.

(3) MSL, Peak Temp. - The Moisture Sensitivity Level rating according to the JEDEC industry standard classifications, and peak solder temperature.

(4) There may be additional marking, which relates to the logo, the lot trace code information, or the environmental category on the device.

(5) Multiple Device Markings will be inside parentheses. Only one Device Marking contained in parentheses and separated by a "-" will appear on a device. If a line is indented then it is a continuation of the previous line and the two combined represent the entire Device Marking for that device.

<sup>(6)</sup> Lead/Ball Finish - Orderable Devices may have multiple material finish options. Finish options are separated by a vertical ruled line. Lead/Ball Finish values may wrap to two lines if the finish value exceeds the maximum column width.

**Important Information and Disclaimer:** The information provided on this page represents TI's knowledge and belief as of the date that it is provided. TI bases its knowledge and belief on information provided by third parties, and makes no representation or warranty as to the accuracy of such information. Efforts are underway to better integrate information from third parties. TI has taken and continues to take reasonable steps to provide representative and accurate information but may not have conducted destructive testing or chemical analysis on incoming materials and chemicals. TI and TI suppliers consider certain information to be proprietary, and thus CAS numbers and other limited information may not be available for release.

In no event shall TI's liability arising out of such information exceed the total purchase price of the TI part(s) at issue in this document sold by TI to Customer on an annual basis.

## TAPE AND REEL INFORMATION



### QUADRANT ASSIGNMENTS FOR PIN 1 ORIENTATION IN TAPE



\*All dimensions are nominal

Device	Package Type	Package Drawing	Pins	SPQ	Reel Diameter (mm)	Reel Width W1 (mm)	A0 (mm)	B0 (mm)	K0 (mm)	P1 (mm)	W (mm)	Pin1 Quadrant
TS12A4516DBVR	SOT-23	DBV	5	3000	180.0	8.4	3.23	3.17	1.37	4.0	8.0	Q3
TS12A4516DR	SOIC	D	8	2500	330.0	12.4	6.4	5.2	2.1	8.0	12.0	Q1
TS12A4517DR	SOIC	D	8	2500	330.0	12.4	6.4	5.2	2.1	8.0	12.0	Q1

**TAPE AND REEL BOX DIMENSIONS**

\*All dimensions are nominal

Device	Package Type	Package Drawing	Pins	SPQ	Length (mm)	Width (mm)	Height (mm)
TS12A4516DBVR	SOT-23	DBV	5	3000	202.0	201.0	28.0
TS12A4516DR	SOIC	D	8	2500	367.0	367.0	35.0
TS12A4517DR	SOIC	D	8	2500	367.0	367.0	35.0



D0008A

# PACKAGE OUTLINE

SOIC - 1.75 mm max height

SMALL OUTLINE INTEGRATED CIRCUIT



4214825/C 02/2019

### NOTES:

1. Linear dimensions are in inches [millimeters]. Dimensions in parenthesis are for reference only. Controlling dimensions are in inches. Dimensioning and tolerancing per ASME Y14.5M.
2. This drawing is subject to change without notice.
3. This dimension does not include mold flash, protrusions, or gate burrs. Mold flash, protrusions, or gate burrs shall not exceed  $.006$  [0.15] per side.
4. This dimension does not include interlead flash.
5. Reference JEDEC registration MS-012, variation AA.

# EXAMPLE BOARD LAYOUT

D0008A

SOIC - 1.75 mm max height

SMALL OUTLINE INTEGRATED CIRCUIT



LAND PATTERN EXAMPLE  
 EXPOSED METAL SHOWN  
 SCALE:8X



SOLDER MASK DETAILS

4214825/C 02/2019

NOTES: (continued)

- 6. Publication IPC-7351 may have alternate designs.
- 7. Solder mask tolerances between and around signal pads can vary based on board fabrication site.

# EXAMPLE STENCIL DESIGN

D0008A

SOIC - 1.75 mm max height

SMALL OUTLINE INTEGRATED CIRCUIT



SOLDER PASTE EXAMPLE  
BASED ON .005 INCH [0.125 MM] THICK STENCIL  
SCALE:8X

4214825/C 02/2019

NOTES: (continued)

8. Laser cutting apertures with trapezoidal walls and rounded corners may offer better paste release. IPC-7525 may have alternate design recommendations.
9. Board assembly site may have different recommendations for stencil design.

DBV0005A



# PACKAGE OUTLINE

SOT-23 - 1.45 mm max height

SMALL OUTLINE TRANSISTOR



4214839/D 11/2018

NOTES:

1. All linear dimensions are in millimeters. Any dimensions in parenthesis are for reference only. Dimensioning and tolerancing per ASME Y14.5M.
2. This drawing is subject to change without notice.
3. Reference JEDEC MO-178.
4. Body dimensions do not include mold flash, protrusions, or gate burrs. Mold flash, protrusions, or gate burrs shall not exceed 0.15 mm per side.

# EXAMPLE BOARD LAYOUT

DBV0005A

SOT-23 - 1.45 mm max height

SMALL OUTLINE TRANSISTOR



LAND PATTERN EXAMPLE  
EXPOSED METAL SHOWN  
SCALE:15X

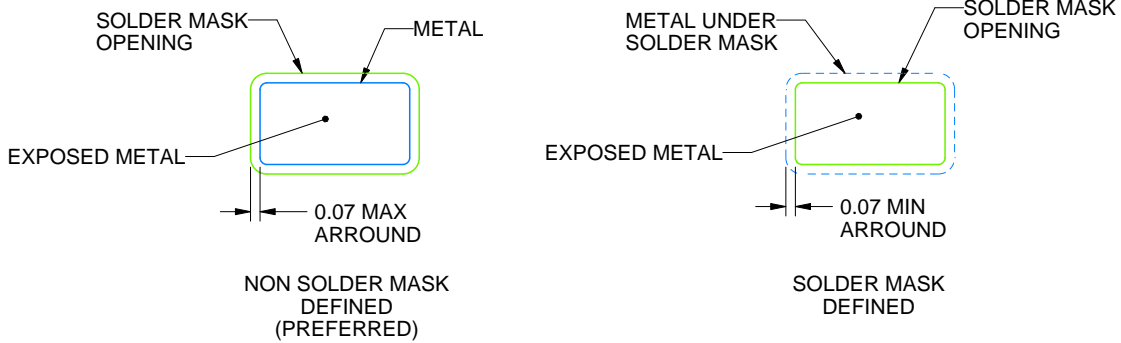

SOLDER MASK DETAILS

4214839/D 11/2018

NOTES: (continued)

5. Publication IPC-7351 may have alternate designs.
6. Solder mask tolerances between and around signal pads can vary based on board fabrication site.

# EXAMPLE STENCIL DESIGN

DBV0005A

SOT-23 - 1.45 mm max height

SMALL OUTLINE TRANSISTOR



SOLDER PASTE EXAMPLE  
BASED ON 0.125 mm THICK STENCIL  
SCALE:15X

4214839/D 11/2018

NOTES: (continued)

7. Laser cutting apertures with trapezoidal walls and rounded corners may offer better paste release. IPC-7525 may have alternate design recommendations.
8. Board assembly site may have different recommendations for stencil design.

## IMPORTANT NOTICE AND DISCLAIMER

TI PROVIDES TECHNICAL AND RELIABILITY DATA (INCLUDING DATASHEETS), DESIGN RESOURCES (INCLUDING REFERENCE DESIGNS), APPLICATION OR OTHER DESIGN ADVICE, WEB TOOLS, SAFETY INFORMATION, AND OTHER RESOURCES "AS IS" AND WITH ALL FAULTS, AND DISCLAIMS ALL WARRANTIES, EXPRESS AND IMPLIED, INCLUDING WITHOUT LIMITATION ANY IMPLIED WARRANTIES OF MERCHANTABILITY, FITNESS FOR A PARTICULAR PURPOSE OR NON-INFRINGEMENT OF THIRD PARTY INTELLECTUAL PROPERTY RIGHTS.

These resources are intended for skilled developers designing with TI products. You are solely responsible for (1) selecting the appropriate TI products for your application, (2) designing, validating and testing your application, and (3) ensuring your application meets applicable standards, and any other safety, security, or other requirements. These resources are subject to change without notice. TI grants you permission to use these resources only for development of an application that uses the TI products described in the resource. Other reproduction and display of these resources is prohibited. No license is granted to any other TI intellectual property right or to any third party intellectual property right. TI disclaims responsibility for, and you will fully indemnify TI and its representatives against, any claims, damages, costs, losses, and liabilities arising out of your use of these resources.

TI's products are provided subject to TI's Terms of Sale ([www.ti.com/legal/termsofsale.html](http://www.ti.com/legal/termsofsale.html)) or other applicable terms available either on [ti.com](http://ti.com) or provided in conjunction with such TI products. TI's provision of these resources does not expand or otherwise alter TI's applicable warranties or warranty disclaimers for TI products.

Mailing Address: Texas Instruments, Post Office Box 655303, Dallas, Texas 75265  
Copyright © 2019, Texas Instruments Incorporated

## Looking for pricing, stock, or lifecycle information?

Click below to explore more details on WIN SOURCE:

 [View TS12A4516DBVR on WIN SOURCE](#)

 [Texas Instruments](#) Information

## Optimize Your Supply Chain with WIN SOURCE Solutions

-  Global Sourcing Solution
-  Obsolete Management
-  Cost Control Management
-  Shortage Management
-  Alternative Solution
-  Excess Inventory Management