



**THE DATASHEET OF
AT93C86-10SC-2.7**



Features

- Low-voltage and Standard-voltage Operation
 - 5.0 ($V_{CC} = 4.5V$ to $5.5V$)
 - 2.7 ($V_{CC} = 2.7V$ to $5.5V$)
- User Selectable Internal Organization
 - 16K: 2048 x 8 or 1024 x 16
- 3-wire Serial Interface
- Sequential Read Operation
- Schmitt Trigger, Filtered Inputs for Noise Suppression
- 2 MHz Clock Rate (5V) Compatibility
- Self-timed Write Cycle (10 ms max)
- High Reliability
 - Endurance: 1 Million Write Cycles
 - Data Retention: 100 Years
 - ESD Protection: >4000V
- Automotive Grade and Extended Temperature Devices Available
- 8-pin PDIP, 8-pin JEDEC SOIC, and 8-pin TSSOP Packages

Description

The AT93C86 provides 16384 bits of serial electrically erasable programmable read only memory (EEPROM) organized as 1024 words of 16 bits each when the ORG Pin is connected to V_{CC} and 2048 words of 8 bits each when it is tied to ground. The device is optimized for use in many industrial and commercial applications where low power and low voltage operations are essential. The AT93C86 is available in space saving 8-pin PDIP, 8-pin JEDEC SOIC and 8-pin TSSOP packages.

(continued)

Pin Configurations

Pin Name	Function
CS	Chip Select
SK	Serial Data Clock
DI	Serial Data Input
DO	Serial Data Output
GND	Ground
VCC	Power Supply
ORG	Internal Organization
DC	Don't Connect

8-pin PDIP

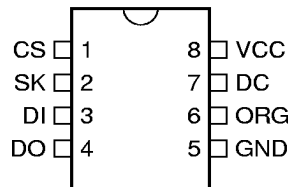

8-pin SOIC

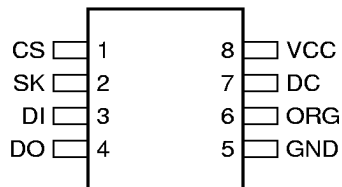

8-pin TSSOP

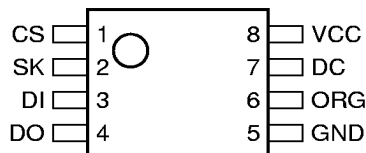

3-wire Serial EEPROM

16K (2048 x 8 or 1024 x 16)

AT93C86

Advanced Information

Rev. 1237A-01/99



The AT93C86 is enabled through the Chip Select pin (CS), and accessed via a 3-wire serial interface consisting of Data Input (DI), Data Output (DO), and Shift Clock (SK). Upon receiving a READ instruction at DI, the address is decoded and the data is clocked out serially on the data output pin DO. The WRITE cycle is completely self-timed and no separate ERASE cycle is required before WRITE.

The WRITE cycle is only enabled when the part is in the ERASE/WRITE ENABLE state. When CS is brought "high" following the initiation of a WRITE cycle, the DO pin outputs the READY/BUSY status of the part.

The AT93C86 is available in 4.5V to 5.5V and 2.7V to 5.5V versions.

Absolute Maximum Ratings*

Operating Temperature	-55°C to +125°C
Storage Temperature	-65°C to +150°C
Voltage on any Pin with Respect to Ground	-1.0V to +7.0V
Maximum Operating Voltage.....	6.25V
DC Output Current.....	5.0 mA

*NOTICE: Stresses beyond those listed under "Absolute Maximum Ratings" may cause permanent damage to the device. This is a stress rating only and functional operation of the device at these or any other conditions beyond those indicated in the operational sections of this specification is not implied. Exposure to absolute maximum rating conditions for extended periods may affect device reliability

Block Diagram

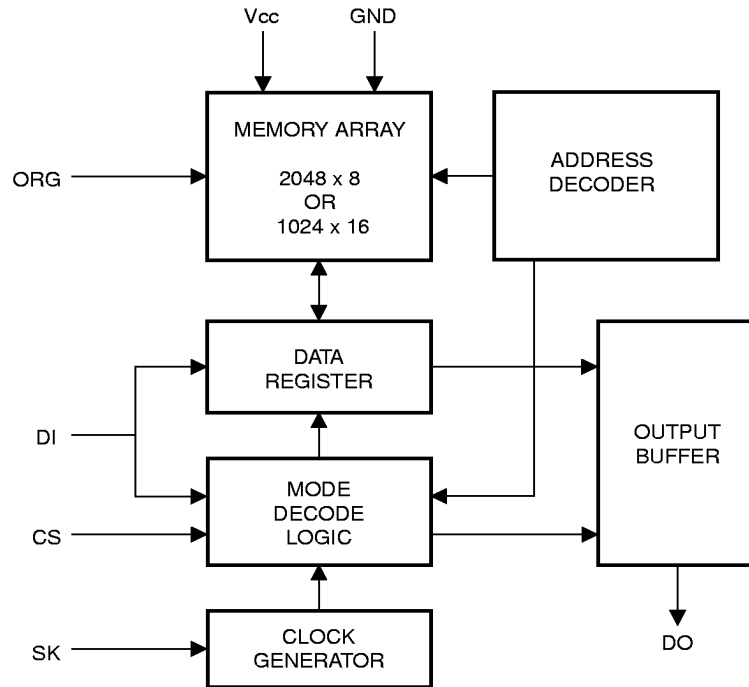

Note: 1. When the ORG pin is connected to V_{CC}, the x 16 organization is selected. When it is connected to ground, the x 8 organization is selected. If the ORG pin is left unconnected, then an internal pullup device (of approximately 1 MΩ) will select the x 16 organization.

Pin Capacitance⁽¹⁾

Applicable over recommended operating range from $T_A = 25^\circ\text{C}$, $f = 1.0\text{ MHz}$, $V_{CC} = +5.0\text{V}$ (unless otherwise noted).

Symbol	Test Conditions	Max	Units	Conditions
C_{OUT}	Output Capacitance (DO)	5	pF	$V_{OUT} = 0\text{V}$
C_{IN}	Input Capacitance (CS, SK, DI)	5	pF	$V_{IN} = 0\text{V}$

Note: 1. This parameter is characterized and is not 100% tested.

DC Characteristics

Applicable over recommended operating range from: $T_{AI} = -40^\circ\text{C}$ to $+85^\circ\text{C}$, $V_{CC} = +2.7\text{V}$ to $+5.5\text{V}$,
 $T_{AC} = 0^\circ\text{C}$ to $+70^\circ\text{C}$, $V_{CC} = +2.7\text{V}$ to $+5.5\text{V}$ (unless otherwise noted).

Symbol	Parameter	Test Condition		Min	Typ	Max	Unit
V_{CC1}	Supply Voltage			2.7		5.5	V
V_{CC2}	Supply Voltage			4.5		5.5	V
I_{CC}	Supply Current	$V_{CC} = 5.0\text{V}$	READ at 1.0 MHz		0.5	2.0	mA
			WRITE at 1.0 MHz		0.5	2.0	mA
I_{SB1}	Standby Current	$V_{CC} = 2.7\text{V}$	CS = 0V		6.0	10.0	μA
I_{SB2}	Standby Current	$V_{CC} = 5.0\text{V}$	CS = 0V		17	30	μA
I_{IL}	Input Leakage	$V_{IN} = 0\text{V}$ to V_{CC}			0.1	1.0	μA
I_{OL}	Output Leakage	$V_{IN} = 0\text{V}$ to V_{CC}			0.1	1.0	μA
$V_{IL1}^{(1)}$ $V_{IH1}^{(1)}$	Input Low Voltage Input High Voltage	$4.5\text{V} \leq V_{CC} \leq 5.5\text{V}$		-0.6 $V_{CC} \times 0.7$		$V_{CC} \times 0.3$ $V_{CC} + 1$	V
$V_{IL2}^{(1)}$ $V_{IH2}^{(1)}$	Input Low Voltage Input High Voltage	$V_{CC} \leq 2.7\text{V}$		-0.6 $V_{CC} \times 0.7$		$V_{CC} \times 0.3$ $V_{CC} + 1$	V
V_{OL1} V_{OH1}	Output Low Voltage Output High Voltage	$4.5\text{V} \leq V_{CC} \leq 5.5\text{V}$	$I_{OL} = 2.1\text{ mA}$			0.4	V
			$I_{OH} = -0.4\text{ mA}$	2.4			V
V_{OL2} V_{OH2}	Output Low Voltage Output High Voltage	$V_{CC} \leq 2.7\text{V}$	$I_{OL} = 0.15\text{ mA}$			0.2	V
			$I_{OH} = -100\ \mu\text{A}$	$V_{CC} - 0.2$			V

Note: 1. V_{IL} min and V_{IH} max are reference only and are not tested.





AC Characteristics

Applicable over recommended operating range from $T_A = -40^\circ\text{C}$ to $+85^\circ\text{C}$, $V_{CC} = \text{As Specified}$,
 $CL = 1$ TTL Gate and 100 pF (unless otherwise noted).

Symbol	Parameter	Test Condition		Min	Typ	Max	Units
f_{SK}	SK Clock Frequency	$4.5V \leq V_{CC} \leq 5.5V$ $2.7V \leq V_{CC} \leq 5.5V$		0 0		2 1	MHz
t_{SKH}	SK High Time	$4.5V \leq V_{CC} \leq 5.5V$ $2.7V \leq V_{CC} \leq 5.5V$		250 250			ns
t_{SKL}	SK Low Time	$4.5V \leq V_{CC} \leq 5.5V$ $2.7V \leq V_{CC} \leq 5.5V$		250 250			ns
t_{CS}	Minimum CS Low Time	$4.5V \leq V_{CC} \leq 5.5V$ $2.7V \leq V_{CC} \leq 5.5V$		250 250			ns
t_{CSS}	CS Setup Time	Relative to SK	$4.5V \leq V_{CC} \leq 5.5V$ $2.7V \leq V_{CC} \leq 5.5V$	50 50			ns
t_{DIS}	DI Setup Time	Relative to SK	$4.5V \leq V_{CC} \leq 5.5V$ $2.7V \leq V_{CC} \leq 5.5V$	100 100			ns
t_{CSH}	CS Hold Time	Relative to SK		0			ns
t_{DIH}	DI Hold Time	Relative to SK	$4.5V \leq V_{CC} \leq 5.5V$ $2.7V \leq V_{CC} \leq 5.5V$	100 100			ns
t_{PD1}	Output Delay to '1'	AC Test	$4.5V \leq V_{CC} \leq 5.5V$ $2.7V \leq V_{CC} \leq 5.5V$			250 250	ns
t_{PD0}	Output Delay to '0'	AC Test	$4.5V \leq V_{CC} \leq 5.5V$ $2.7V \leq V_{CC} \leq 5.5V$			250 250	ns
t_{SV}	CS to Status Valid	AC Test	$4.5V \leq V_{CC} \leq 5.5V$ $2.7V \leq V_{CC} \leq 5.5V$			250 250	ns
t_{DF}	CS to DO in High Impedance	AC Test $CS = V_{IL}$	$4.5V \leq V_{CC} \leq 5.5V$ $2.7V \leq V_{CC} \leq 5.5V$			100 100	ns
t_{WP}	Write Cycle Time			0.1		10	ms
			$4.5V \leq V_{CC} \leq 5.5V$		4		ms
Endurance ⁽¹⁾	5.0V, 25°C, Page Mode			1M			Write Cycles

Note: 1. This parameter is characterized and is not 100% tested.

Instruction Set for the AT93C86

Instruction	SB	Op Code	Address		Data		Comments
			x 8	x 16	x 8	x 16	
READ	1	10	$A_{10} - A_0$	$A_9 - A_0$			Reads data stored in memory, at specified address.
EWEN	1	00	11XXXXXXXX	11XXXXXXXX			Write enable must precede all programming modes.
ERASE	1	11	$A_{10} - A_0$	$A_9 - A_0$			Erases memory location $A_n - A_0$.
WRITE	1	01	$A_{10} - A_0$	$A_9 - A_0$	$D_7 - D_0$	$D_{15} - D_0$	Writes memory location $A_n - A_0$.

Instruction Set for the AT93C86

Instruction	SB	Op Code	Address		Data		Comments
			x 8	x 16	x 8	x 16	
ERAL	1	00	10XXXXXXXX	10XXXXXXXX			Erases all memory locations. Valid only at $V_{CC} = 4.5V$ to $5.5V$.
WRAL	1	00	01XXXXXXXX	01XXXXXXXX	$D_7 - D_0$	$D_{15} - D_0$	Writes all memory locations. Valid when $V_{CC} = 4.5V$ to $5.5V$ and Disable Register cleared.
EWDS	1	00	00XXXXXXXX	00XXXXXXXX			Disables all programming instructions.

Functional Description

The AT93C86 is accessed via a simple and versatile 3-wire serial communication interface. Device operation is controlled by seven instructions issued by the host processor. **A valid instruction starts with a rising edge of CS** and consists of a Start Bit (logic "1") followed by the appropriate Op Code and the desired memory Address location.

READ (READ): The Read (READ) instruction contains the Address code for the memory location to be read. After the instruction and address are decoded, data from the selected memory location is available at the serial output pin DO. Output data changes are synchronized with the rising edges of serial clock SK. It should be noted that a dummy bit (logic "0") precedes the 8- or 16-bit data output string.

ERASE/WRITE (EWEN): To assure data integrity, the part automatically goes into the Erase/Write Disable (EWDS) state when power is first applied. An Erase/Write Enable (EWEN) instruction must be executed first before any programming instructions can be carried out. Please note that once in the Erase/Write Enable state, programming remains enabled until an Erase/Write Disable (EWDS) instruction is executed or V_{CC} power is removed from the part.

ERASE (ERASE): The Erase (ERASE) instruction programs all bits in the specified memory location to the logical "1" state. The self-timed erase cycle starts once the ERASE instruction and address are decoded. The DO pin outputs the READY/BUSY status of the part if CS is brought high after being kept low for a minimum of 250 ns (t_{CS}). A logic "1" at pin DO indicates that the selected memory location has been erased, and the part is ready for another instruction.

WRITE (WRITE): The Write (WRITE) instruction contains the 8 or 16 bits of data to be written into the specified memory location. The self-timed programming cycle, t_{WP} , starts after the last bit of data is received at serial data input pin DI. The DO pin outputs the READY/BUSY status of the part if CS is brought high after being kept low for a minimum of 250 ns (t_{CS}). A logic "0" at DO indicates that programming is still in progress. A logic "1" indicates that the memory location at the specified address has been written with the data pattern contained in the instruction and the part is ready for further instructions. **A READY/BUSY status cannot be obtained if the CS is brought high after the end of the self-timed programming cycle, t_{WP} .**

ERASE ALL (ERAL): The Erase All (ERAL) instruction programs every bit in the memory array to the logic "1" state and is primarily used for testing purposes. The DO pin outputs the READY/BUSY status of the part if CS is brought high after being kept low for a minimum of 250 ns (t_{CS}). The ERAL instruction is valid only at $V_{CC} = 5.0V \pm 10\%$.

WRITE ALL (WRAL): The Write All (WRAL) instruction programs all memory locations with the data patterns specified in the instruction. The DO pin outputs the READY/BUSY status of the part if CS is brought high after being kept low for a minimum of 250 ns (t_{CS}). The WRAL instruction is valid only at $V_{CC} = 5.0V \pm 10\%$.

ERASE/WRITE DISABLE (EWDS): To protect against accidental data disturb, the Erase/Write Disable (EWDS) instruction disables all programming modes and should be executed after all programming operations. The operation of the READ instruction is independent of both the EWEN and EWDS instructions and can be executed at any time.



Timing Diagrams

Synchronous Data Timing

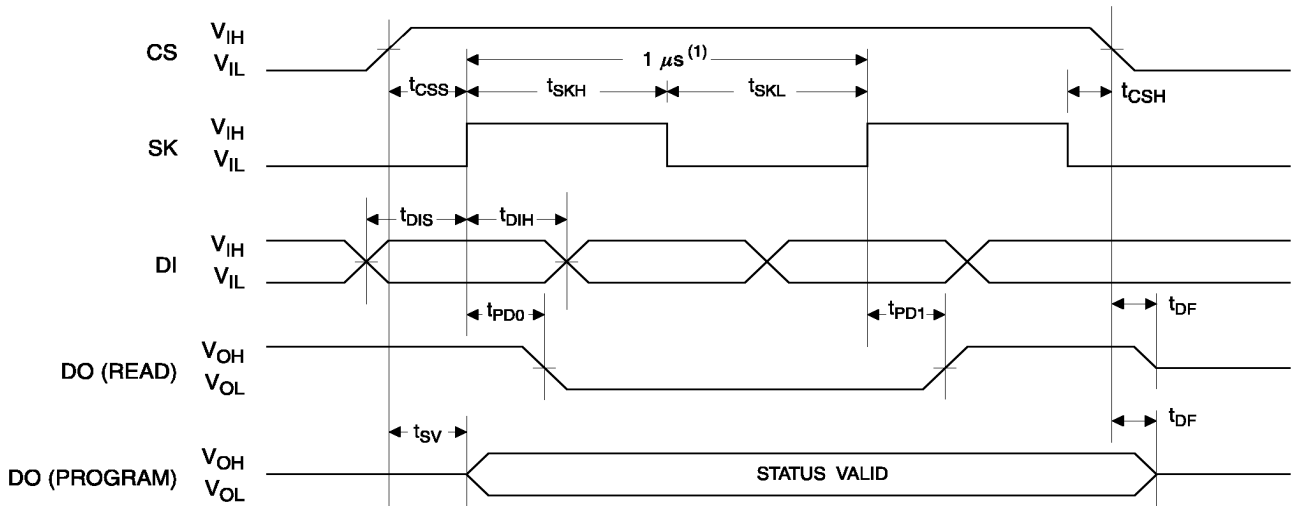

Note: 1. This is the minimum SK period.

Organization Key for Timing Diagrams

I/O	AT93C86 (16K)	
	x 8	x 16
A_N	A_{10}	A_9
D_N	D_7	D_{15}

READ Timing

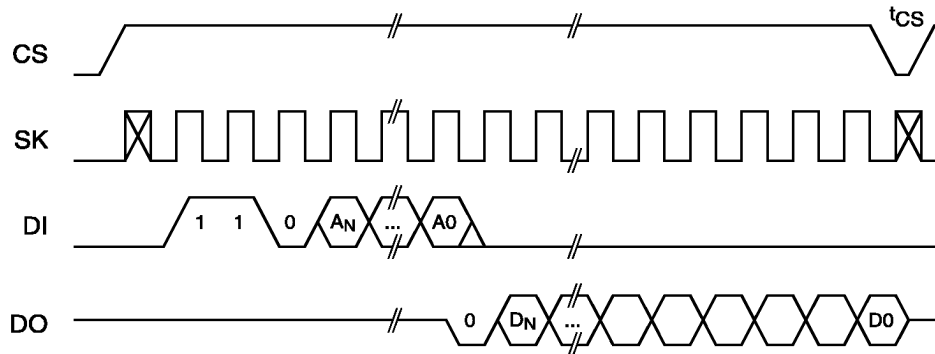

EWEN Timing

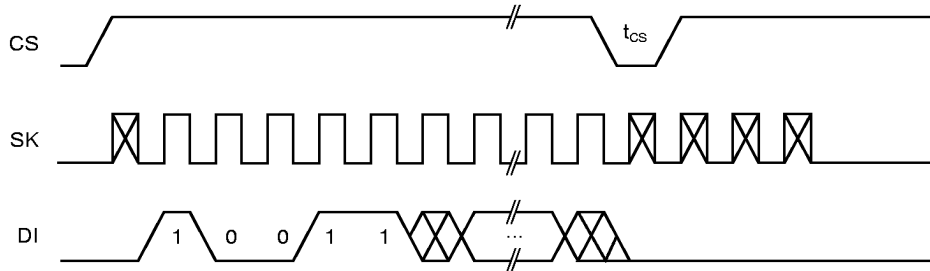

EWDS Timing

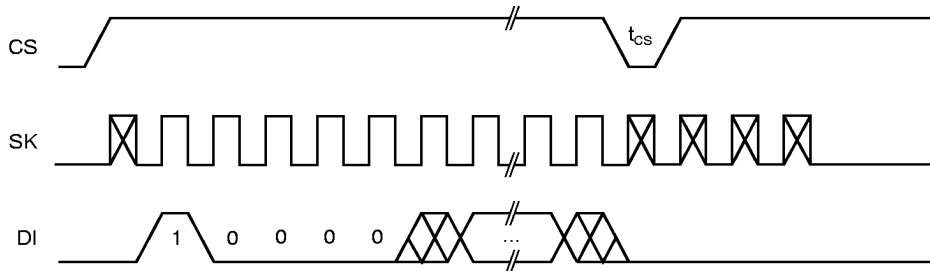

WRITE Timing

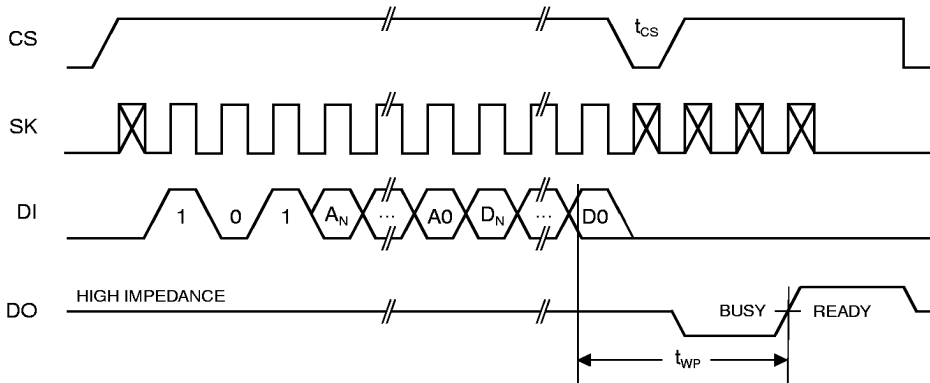

WRAL Timing⁽¹⁾

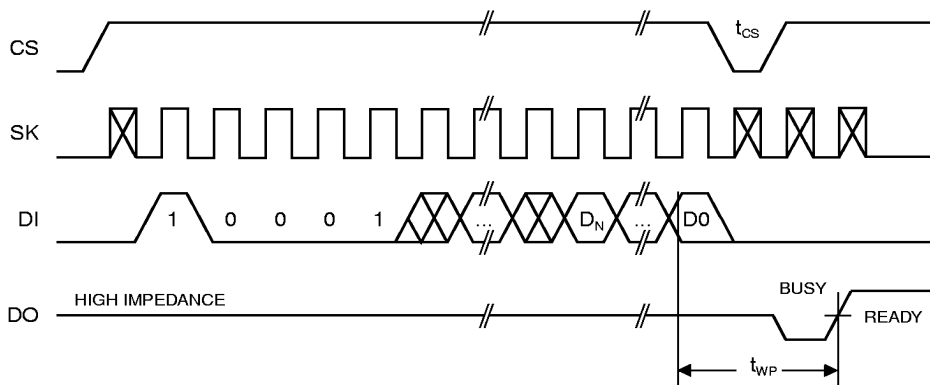

Note: 1. Valid only at $V_{CC} = 4.5V$ to $5.5V$.



ERASE Timing

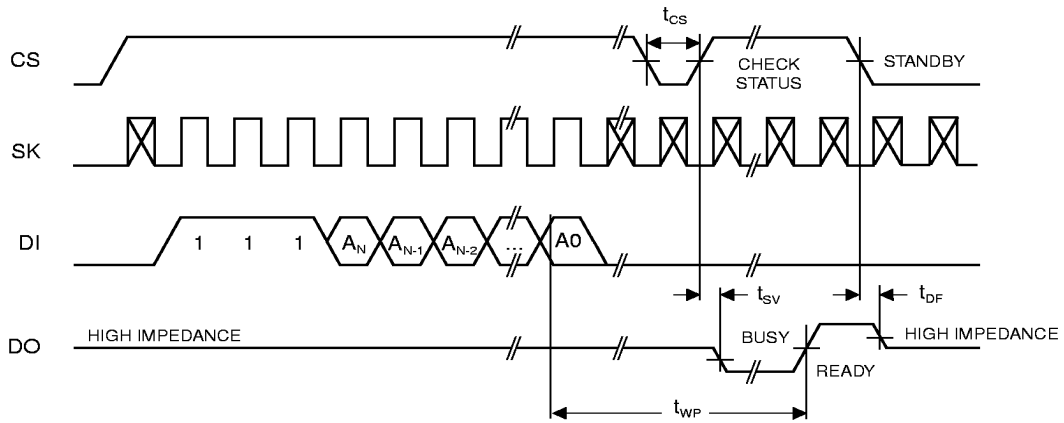

ERAL Timing⁽¹⁾

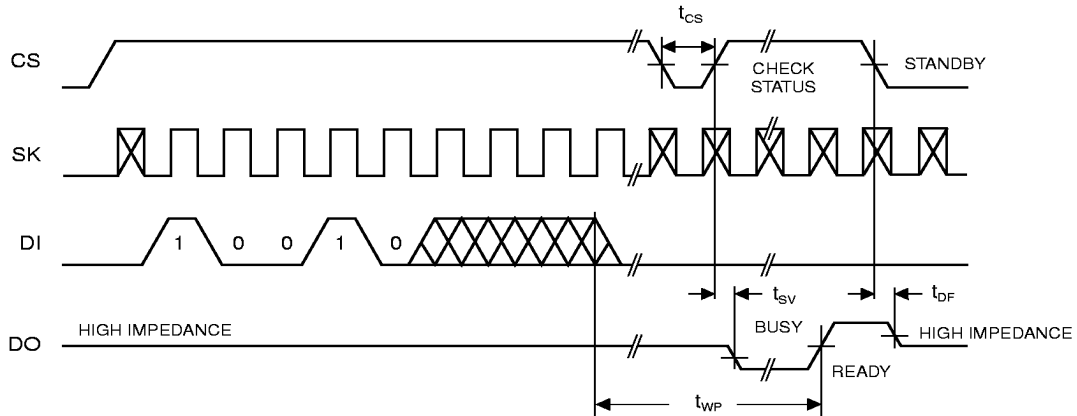

Note: 1. Valid only at $V_{CC} = 4.5V$ to $5.5V$.

AT93C86 Ordering Information

t_{WP} (max) (ms)	I_{CC} (max) (μA)	I_{SB} (max) (μA)	f_{MAX} (kHz)	Ordering Code	Package	Operation Range
10	2000	30.0	2000	AT93C86-10PC AT93C86-10SC AT93C86-10TC	8P3 8S1 8T	Commercial (0°C to 70°C)
		30.0		AT93C86-10PI AT93C86-10SI AT93C86-10TI	8P3 8S1 8T	Industrial (-40°C to 85°C)
10	800	10.0	1000	AT93C86-10PC-2.7 AT93C86-10SC-2.7 AT93C86-10TC-2.7	8P3 8S1 8T	Commercial (0°C to 70°C)
		10.0		AT93C86-10PI-2.7 AT93C86-10SI-2.7 AT93C86-10TI-2.7	8P3 8S1 8T	Industrial (-40°C to 85°C)

Package Type	
8P3	8-lead, 0.300" Wide, Plastic Dual Inline Package (PDIP)
8S1	8-lead, 0.150" Wide, Plastic Gull Wing Small Outline (JEDEC SOIC)
8T	8-lead, 0.170" Wide, Thin Shrink Small Outline Package (TSSOP)
Options	
Blank	Standard Operation (4.5V to 5.5V)
-2.7	Low Voltage (2.7V to 5.5V)



Packaging Information

8P3, 8-Lead, 0.300" Wide, Plastic Dual Inline Package (PDIP)
 Dimensions in Inches and (Millimeters)
 JEDEC STANDARD MS-001 BA

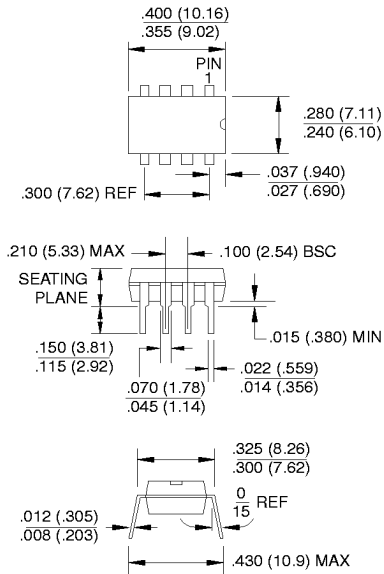

8S1, 8-Lead, 0.150" Wide, Plastic Gull Wing Small Outline (JEDEC SOIC)
 Dimensions in Inches and (Millimeters)

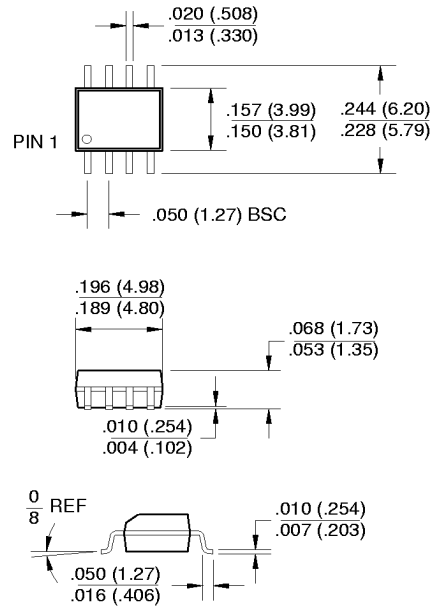

8T, 8-Lead, 0.170" Wide Thin Shrink Small Outline Package (TSSOP)
 Dimensions in Millimeters and (Inches)*

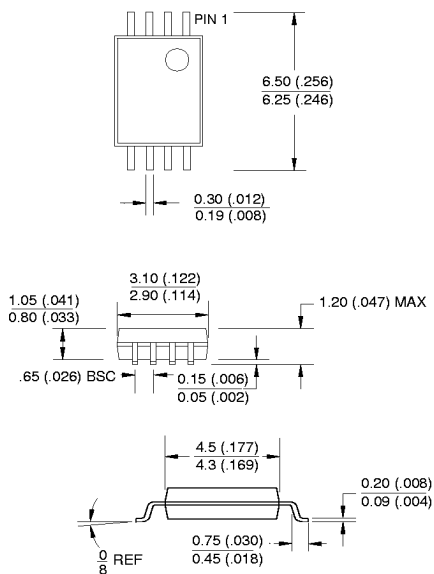

*Controlling dimension: millimeters

Looking for pricing, stock, or lifecycle information?

Click below to explore more details on WIN SOURCE:

- ⊖ [View AT93C86-10SC-2.7 on WIN SOURCE](#)
- ⊖ [Microchip Technology Information](#)

Optimize Your Supply Chain with WIN SOURCE Solutions

- ✓ Global Sourcing Solution
- ✓ Obsolete Management
- ✓ Cost Control Management
- ✓ Shortage Management
- ✓ Alternative Solution
- ✓ Excess Inventory Management