



Is Now Part of



ON Semiconductor®

To learn more about ON Semiconductor, please visit our website at
www.onsemi.com

Please note: As part of the Fairchild Semiconductor integration, some of the Fairchild orderable part numbers will need to change in order to meet ON Semiconductor's system requirements. Since the ON Semiconductor product management systems do not have the ability to manage part nomenclature that utilizes an underscore (_), the underscore (_) in the Fairchild part numbers will be changed to a dash (-). This document may contain device numbers with an underscore (_). Please check the ON Semiconductor website to verify the updated device numbers. The most current and up-to-date ordering information can be found at www.onsemi.com. Please email any questions regarding the system integration to Fairchild_questions@onsemi.com.

ON Semiconductor and the ON Semiconductor logo are trademarks of Semiconductor Components Industries, LLC dba ON Semiconductor or its subsidiaries in the United States and/or other countries. ON Semiconductor owns the rights to a number of patents, trademarks, copyrights, trade secrets, and other intellectual property. A listing of ON Semiconductor's product/patent coverage may be accessed at www.onsemi.com/site/pdf/Patent-Marking.pdf. ON Semiconductor reserves the right to make changes without further notice to any products herein. ON Semiconductor makes no warranty, representation or guarantee regarding the suitability of its products for any particular purpose, nor does ON Semiconductor assume any liability arising out of the application or use of any product or circuit, and specifically disclaims any and all liability, including without limitation special, consequential or incidental damages. Buyer is responsible for its products and applications using ON Semiconductor products, including compliance with all laws, regulations and safety requirements or standards, regardless of any support or applications information provided by ON Semiconductor. "Typical" parameters which may be provided in ON Semiconductor data sheets and/or specifications can and do vary in different applications and actual performance may vary over time. All operating parameters, including "Typicals" must be validated for each customer application by customer's technical experts. ON Semiconductor does not convey any license under its patent rights nor the rights of others. ON Semiconductor products are not designed, intended, or authorized for use as a critical component in life support systems or any FDA Class 3 medical devices or medical devices with a same or similar classification in a foreign jurisdiction or any devices intended for implantation in the human body. Should Buyer purchase or use ON Semiconductor products for any such unintended or unauthorized application, Buyer shall indemnify and hold ON Semiconductor and its officers, employees, subsidiaries, affiliates, and distributors harmless against all claims, costs, damages, and expenses, and reasonable attorney fees arising out of, directly or indirectly, any claim of personal injury or death associated with such unintended or unauthorized use, even if such claim alleges that ON Semiconductor was negligent regarding the design or manufacture of the part. ON Semiconductor is an Equal Opportunity/Affirmative Action Employer. This literature is subject to all applicable copyright laws and is not for resale in any manner.

MM74HC595 8-Bit Shift Register with Output Latches

Features

- Low Quiescent current: 80µA Maximum (74HC Series)
- Low Input Current: 1µA Maximum
- 8-Bit Serial-In, Parallel-Out Shift Register with Storage
- Wide Operating Voltage Range: 2V–6V
- Cascadable
- Shift Register has Direct Clear
- Guaranteed Shift Frequency: DC to 30MHz

Description

The MM74HC595 high-speed shift register utilizes advanced silicon-gate CMOS technology. This device possesses the high noise immunity and low power consumption of standard CMOS integrated circuits, as well as the ability to drive 15 LS-TTL loads.

This device contains an eight-bit serial-in, parallel-out, shift register that feeds an eight-bit D-type storage register. The storage register has eight 3-state outputs. Separate clocks are provided for both the shift register and the storage register. The shift register has a direct-overriding clear, serial input, and serial output (standard) pins for cascading. Both the shift register and storage register use positive-edge triggered clocks. If both clocks are connected together, the shift register state is one clock pulse ahead of the storage register.

The 74HC logic family is speed, function, and pin-out compatible with the standard 74LS logic family. All inputs are protected from damage due to static discharge by internal diode clamps to V_{CC} and ground.

Ordering Information

Part Number	Operating Temperature Range	 Eco Status	Package	Packing Method
MM74HC595M	-40 to +85°C	RoHS	16-Lead, Small Outline Integrated Circuit (SOIC), JEDEC MS-012, 0.150 Inch Narrow	Tubes
MM74HC595MX	-40 to +85°C	RoHS		Tape and Reel
MM74HC595SJ	-40 to +85°C	RoHS	16-Lead, Small Outline Package (SOP), EIAJ TYPE II, 5.3mm Wide	Tubes
MM74HC595SJX	-40 to +85°C	RoHS		Tape and Reel
MM74HC595MTC	-40 to +85°C	RoHS	16-Lead, Thin Shrink Small Outline Package (TSSOP), JEDEC MO-153, 4.4mm Wide	Tubes
MM74HC595MTCX	-40 to +85°C	RoHS		Tape and Reel
MM74HC595N	-40 to +85°C	RoHS	16-Lead, Plastic Dual In-Line Package (PDIP), JEDEC MS-001, 0.300 Inch Wide	Tubes

 For Fairchild's definition of Eco Status, please visit: http://www.fairchildsemi.com/company/green/rohs_green.html.

Pin Configuration

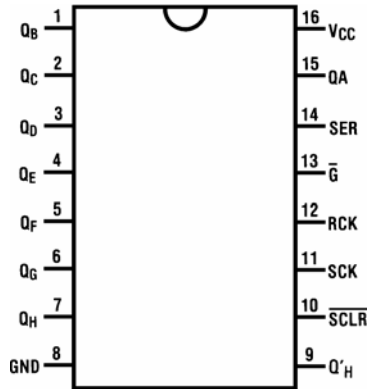

Figure 2. Pin Configuration

Pin Definitions

Pin #	Name	Description
1	Q _B	Output Bit B
2	Q _C	Output Bit C
3	Q _D	Output Bit D
4	Q _E	Output Bit E
5	Q _F	Output Bit F
6	Q _G	Output Bit G
7	Q _H	Output Bit H
8	GND	Ground
9	Q' _H	Serial Data Output
10	SCLR	Shift Register Clear
11	SCK	Shift Register Clock Input
12	RCK	Storage Register Clock Input
13	\overline{G}	Output Enable
14	SER	Serial Data Input
15	QA	Output Bit A
16	V _{CC}	Supply Voltage

Truth Table

RCK	SCK	SCLR	G	Function
X	X	X	H	QA through Q _H = 3-state
X	X	L	L	Shift register clocked; Q' _H = 0
X	↑	H	L	Shift register clocked; Q _N = Q _{N-1} , Q ₀ = SER
↑	X	H	L	Contents of shift; register transferred to output latches

L = Logic Level LOW

H = Logic Level HIGH

X = Don't Care

↑ = Transition from LOW to HIGH level

Absolute Maximum Ratings⁽¹⁾

Stresses exceeding the absolute maximum ratings may damage the device. The device may not function or be operable above the recommended operating conditions and stressing the parts to these levels is not recommended. In addition, extended exposure to stresses above the recommended operating conditions may affect device reliability. The absolute maximum ratings are stress ratings only.

Symbol	Parameter	Min.	Max.	Unit
V _{CC}	Supply Voltage	-0.5	7.0	V
V _{IN}	DC Input Voltage	-1.5 to V _{CC+}	1.5	V
V _{OUT}	DC Output Voltage	-0.5 to V _{CC+}	0.5	V
I _{IK} , I _{OK}	Clamp Diode Current		±20	mA
I _{OUT}	DC Output Current, per Pin		±35	mA
I _{CC}	DC VCC or GND Current, per Pin		±70	mA
T _{STG}	Storage Temperature Range	-65	+150	°C
P _D	Power Dissipation	PDIP ⁽²⁾	600	mW
		SOIC Package Only	500	
T _L	Lead Temperature		+260	°C
ESD	Electrostatic Discharge Capability	Human Body Model, JESD22-A114	4000	V

Notes:

1. Unless otherwise specified all voltages are referenced to ground.
2. Power dissipation temperature derating, plastic package (PDIP); 12mW/°C from -65 to +85°C.

Recommended Operating Conditions

The Recommended Operating Conditions table defines the conditions for actual device operation. Recommended operating conditions are specified to ensure optimal performance to the datasheet specifications. Fairchild does not recommend exceeding them or designing to Absolute Maximum Ratings.

Symbol	Parameter	Min.	Max.	Unit
V _{CC}	Supply Voltage	2	6	V
V _{IN} , V _{OUT}	DC Input or Output Voltage	0	V _{CC}	V
T _A	Operating Temperature Range	-40	+85	°C
t _R , t _F	Input Rise and Fall Times	V _{CC} =2.0V	1000	ns
		V _{CC} =4.5V	500	
		V _{CC} =6.0V	400	

Electrical Characteristics⁽³⁾

Symbol	Parameter	Conditions	V _{CC}	T _A =25°C			T _A =-40 to 85°C	T _A =-55 to 125°C	Units
				Typ.	Guaranteed Limits				
V _{IH}	Minimum HIGH Level Input Voltage		2.0V		1.50	1.50	1.50	V	
			4.5V		3.15	3.15	3.15		
			6.0V		4.20	4.20	4.20		
V _{IL}	Minimum LOW Level Input Voltage		2.0V		0.50	0.50	0.50	V	
			4.5V		1.35	1.35	1.35		
			6.0V		1.80	1.80	1.80		
V _{OH}	Minimum HIGH Level Output Voltage	V _{IN} =V _{IH} or V _{IL}	I _{OUT} ≤ 20μA	2.0V	2.00	1.90	1.90	1.90	V
				4.5V	4.50	4.40	4.40	4.40	
				6.0V	6.00	5.90	5.90	5.90	
	Q' _H	V _{IN} =V _{IH} or V _{IL}	I _{OUT} ≤ 4.0mA	4.5V	4.20	3.98	3.84	3.70	V
				6.0V	5.20	5.48	5.34	5.20	
	Q _A through Q _H	V _{IN} =V _{IH} or V _{IL}	I _{OUT} ≤ 6.0mA	4.5V	4.20	3.98	3.84	3.70	V
6.0V				5.70	5.48	5.34	5.20		
V _{OL}	Minimum LOW Level Output Voltage	V _{IN} =V _{IH} or V _{IL}	I _{OUT} ≤ 20μA	2.0V	0	0.10	0.10	0.10	V
				4.5V	0	0.10	0.10	0.10	
				6.0V	0	0.10	0.10	0.10	
	Q' _H	V _{IN} =V _{IH} or V _{IL}	I _{OUT} ≤ 4.0mA	4.5V	0.20	0.26	0.33	0.40	V
				6.0V	0.20	0.26	0.33	0.40	
	Q _A through Q _H	V _{IN} =V _{IH} or V _{IL}	I _{OUT} ≤ 6.0mA	4.5V	0.20	0.26	0.33	0.40	V
6.0V				0.20	0.26	0.33	0.40		
I _{IN}	Maximum Input Output Leakage	V _{IN} =V _{CC} or GND	6.0V		±0.1	±1.0	±1.0	μA	
I _{OZ}	Maximum 3-State Output Leakage	V _{OUT} =V _{CC} or GND Ḡ=V _{IH}	6.0V		±0.5	±5.0	±10	μA	
I _{CC}	Maximum Quiescent Supply Current	V _{IN} =V _{CC} or GND I _{OUT} =μA	6.0V		8.0	80	160	μA	

Note:

3. For a power supply of 5V ±10%, the worst-case output voltages (V_{OH}, and V_{OL}) occur for HC at 4.5V. The 4.5V values should be used when designing with this supply. Worst-case V_{IH} and V_{IL} occur at V_{CC} = 5.5V and 4.5V, respectively; V_{IH} value at 5.5V is 3.85V. The worst-case leakage current (I_{IN}, I_{CC}, and I_{OZ}) occurs for CMOS at the higher voltage; so the 6.0V values should be used.

AC Electrical Characteristics

$V_{CC} = 5V$, $T_A = 25^\circ C$, $t_r = t_f = 6ns$.

Symbol	Parameter	Conditions	Typ.	Guaranteed Limit	Units
f_{MAX}	Maximum Operating Frequency of SCK		50	30	MHz
t_{PHL}, t_{PLH}	Maximum Propagation Delay, SCK to Q'_H	$C_L=45pF$	12	20	ns
	Maximum Propagation Delay, RCK to Q_A thru Q'_H		18	30	
t_{PZH}, t_{PZL}	Maximum Output Enable Time from \overline{G} to Q_A thru Q'_H	$R_L=1k\Omega, C_L=45pF$	17	28	ns
t_{PHZ}, t_{PLZ}	Maximum Output Disable Time from \overline{G} to Q_A thru Q'_H	$R_L=1k\Omega, C_L=45pF$	15	25	ns
t_s	Minimum Setup Time from SER to SCK			20	ns
	Minimum Setup Time from \overline{SCLR} to SCK			20	ns
	Minimum Setup Time from SER to RCK ⁽⁴⁾			40	ns
t_H	Minimum Hold Time from SER to SCK			0	ns
t_w	Minimum Pulse Width of SCK or RCK			16	ns

Note:

- This setup time ensures the register will see stable data from the shift-register outputs. The clocks may be connected together in which case the storage register state will be one clock pulse behind the shift register.

Electrical Characteristics

$V_{CC} = 2.0\text{--}6.0\text{V}$, $C_L = 50\text{pF}$, $t_r = t_f = 6\text{ns}$ unless otherwise specified.

Symbol	Parameter	Conditions	V_{CC}	$T_A = 25^\circ\text{C}$		$T_A = -40$ to	$T_A = -55$	Units	
				Typ.	Guaranteed Limits		85°C		to 125°C
f_{MAX}	Maximum Operating Frequency	$C_L = 50\text{pF}$	2.0V	10.0	6.0	4.8	4.0	ns	
			4.5V	45.0	30.0	24.0	20.0		
			6.0V	50.0	35.0	28.0	24.0		
t_{PHL}, t_{PLH}	Maximum Propagation Delay, SCK to Q'_H	$C_L = 50\text{pF}$	2.0V	58.0	210.0	235.0	315.0	ns	
			2.0V	83.0	294.0	367.0	441.0		
		$C_L = 150\text{pF}$	4.5V	14.0	42.0	53.0	63.0		
			4.5V	17.0	58.0	74.0	88.0		
		$C_L = 50\text{pF}$	6.0V	10.0	36.0	45.0	54.0		
			6.0V	14.0	50.0	63.0	76.0		
	Maximum Propagation Delay, RCK to Q_A thru Q'_H	$C_L = 50\text{pF}$	2.0V	70.0	175.0	220.0	265.0	ns	
			2.0V	105.0	245.0	306.0	368.0		
		$C_L = 150\text{pF}$	4.5V	21.0	35.0	44.0	53.0		
			4.5V	28.0	49.0	61.0	74.0		
		$C_L = 50\text{pF}$	6.0V	18.0	30.0	37.0	45.0		
	6.0V		26.0	42.0	53.0	63.0			
	Maximum Propagation Delay, SCLR to Q'_H		2.0V		175.0	221.0	261.0	ns	
			4.5V		35.0	44.0	52.0		
			6.0V		30.0	37.0	44.0		
t_{PZH}, t_{PZL}	Maximum Output Enable Time from \overline{G} to Q_A thru Q'_H	$R_L = 1\text{k}\Omega$	$C_L = 50\text{pF}$	2.0V	75.0	175.0	220.0	265.0	ns
			$C_L = 150\text{pF}$	2.0V	100.0	245.0	306.0	368.0	
		$C_L = 50\text{pF}$	4.5V	15.0	35.0	44.0	53.0		
			4.5V	20.0	49.0	61.0	74.0		
		$C_L = 150\text{pF}$	6.0V	13.0	30.0	37.0	45.0		
			6.0V	17.0	42.0	53.0	63.0		
t_{PHZ}, t_{PLZ}	Maximum Output Disable Time from \overline{G} to Q_A thru Q'_H	$R_L = 1\text{k}\Omega, C_L = 50\text{pF}$	2.0V	75.0	175.0	220.0	265.0	ns	
			4.5V	15.0	35.0	44.0	53.0		
			6.0V	13.0	30.0	37.0	45.0		

Continued on the following page...

Electrical Characteristics

$V_{CC} = 2.0\text{--}6.0\text{V}$, $C_L = 50\text{pF}$, $t_r = t_f = 6\text{ns}$ unless otherwise specified.

Symbol	Parameter	Conditions	V_{CC}	$T_A=25^\circ\text{C}$		$T_A=-40$ to	$T_A=-55$	Units
				Typ.	Guaranteed Limits			
t_s	Minimum Setup Time from SER to SCK	$R_L=1\text{k}\Omega$, $C_L=50\text{pF}$	2.0V		100	125	150	ns
			4.5V		20	25	30	
			6.0V		17	21	25	
t_R	Minimum Removal Time from SCLR to SCK		2.0V		50	63	75	ns
			4.5V		10	13	15	
			6.0V		9	11	13	
t_s	Minimum Setup Time from SCK to RCK		2.0V		100	125	150	ns
			4.5V		20	25	30	
			6.0V		17	21	26	
t_H	Minimum Hold Time from SER to SCK		2.0V		5	5	5	ns
			4.5V		5	5	5	
			6.0V		5	5	5	
t_W	Minimum Pulse Width of SCK or SCLR		2.0V	30	80	100	120	ns
			4.5V	9	16	20	24	
			6.0V	8	14	18	22	
t_R, t_F	Maximum Input Rise and Fall Time, Clock		2.0V		1000	1000	1000	ns
			4.5V		500	500	500	
			6.0V		400	400	400	
t_{THL}, t_{TLH}	Maximum Output Rise and Fall Time $Q_A\text{--}Q_H$		2.0V	25	60	75	90	ns
			4.5V	7	12	15	18	
			6.0V	6	10	13	15	
	Maximum Output Rise and Fall Time Q'_H		2.0V		75	95	110	ns
			4.5V		15	19	22	
			6.0V		13	16	19	
C_{PD}	Power Dissipation Capacitance, Outputs Enabled ⁽⁵⁾	$\overline{G}=V_{CC}$		90				pF
		$\overline{G}=GND$		150				
C_{IN}	Maximum Input Capacitance			5	10	10	10	pF
C_{OUT}	Maximum Output Capacitance			15	20	20	20	pF

Note:

5. C_{PD} determines the no load dynamic power consumption, $P_D = C_{PD} V_{CC}^2 f + I_{CC} V_{CC}$, and the no load dynamic current consumption, $I_S = C_{PD} V_{CC} f + I_{CC}$.

Timing Diagram

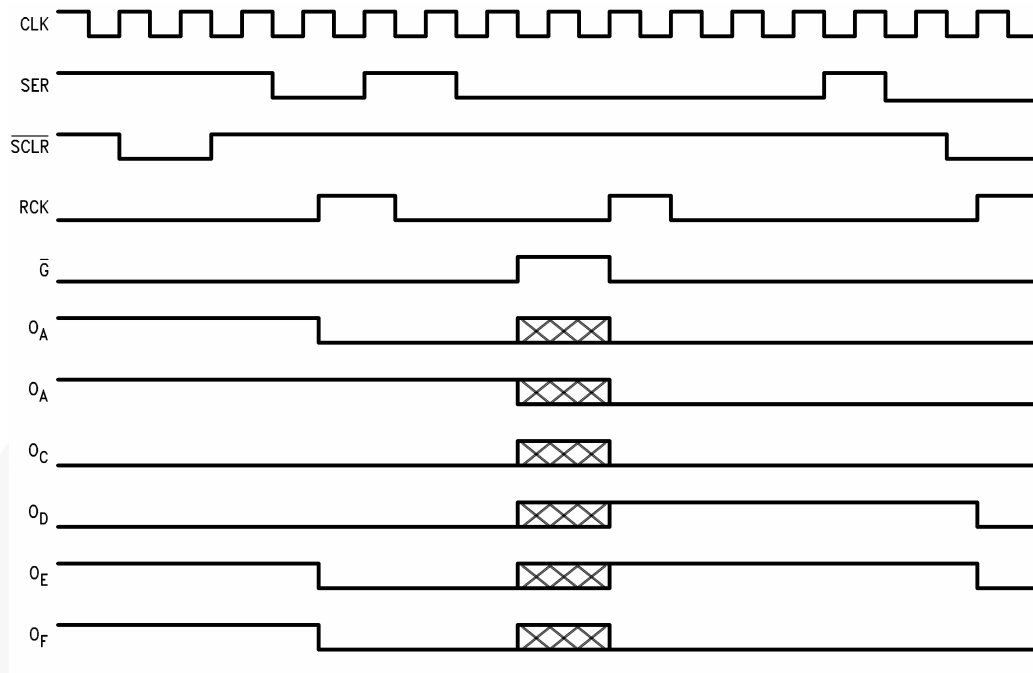

Figure 3. Timing Diagram

Note:

6. XXX Implies that the output is in 3-state mode.

Physical Dimensions

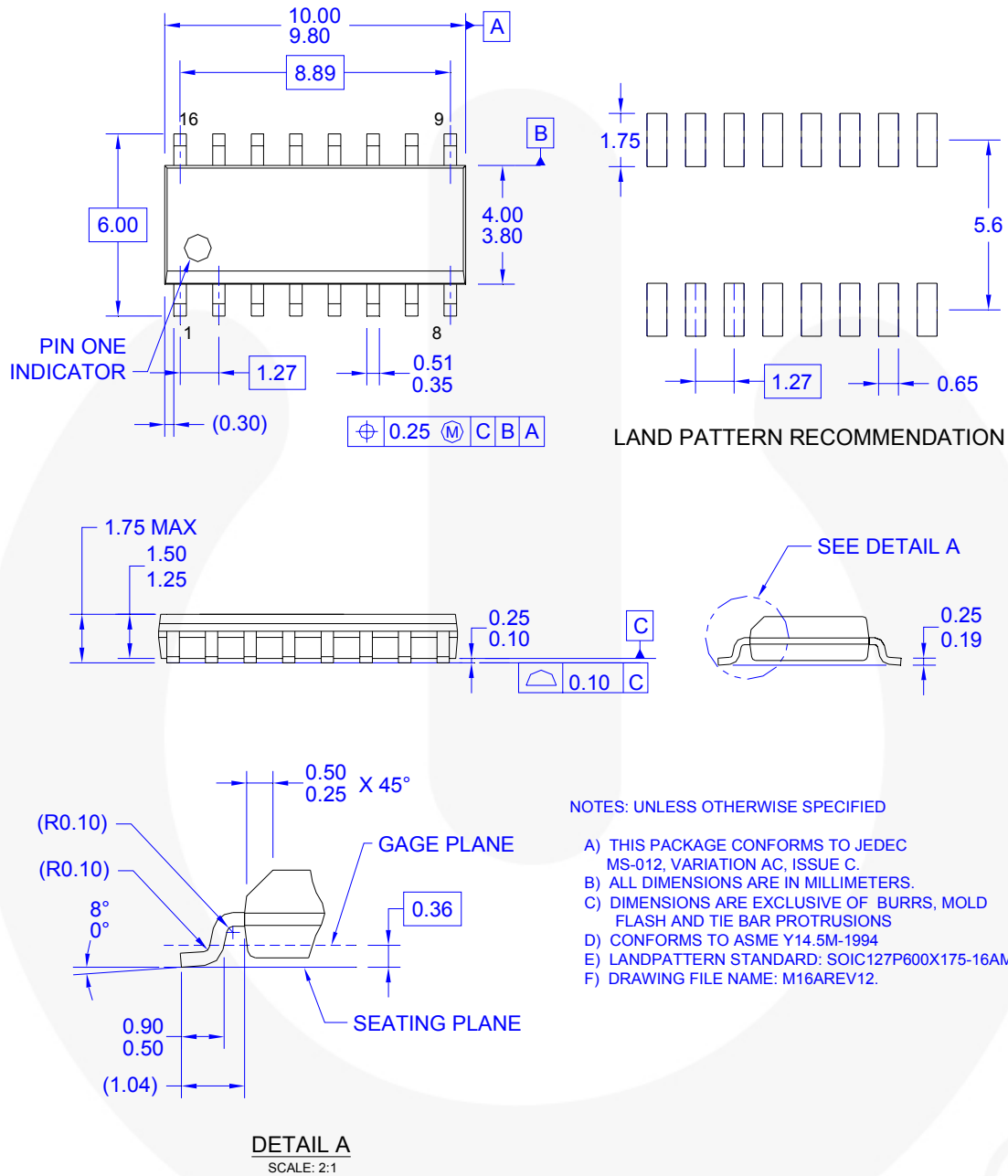
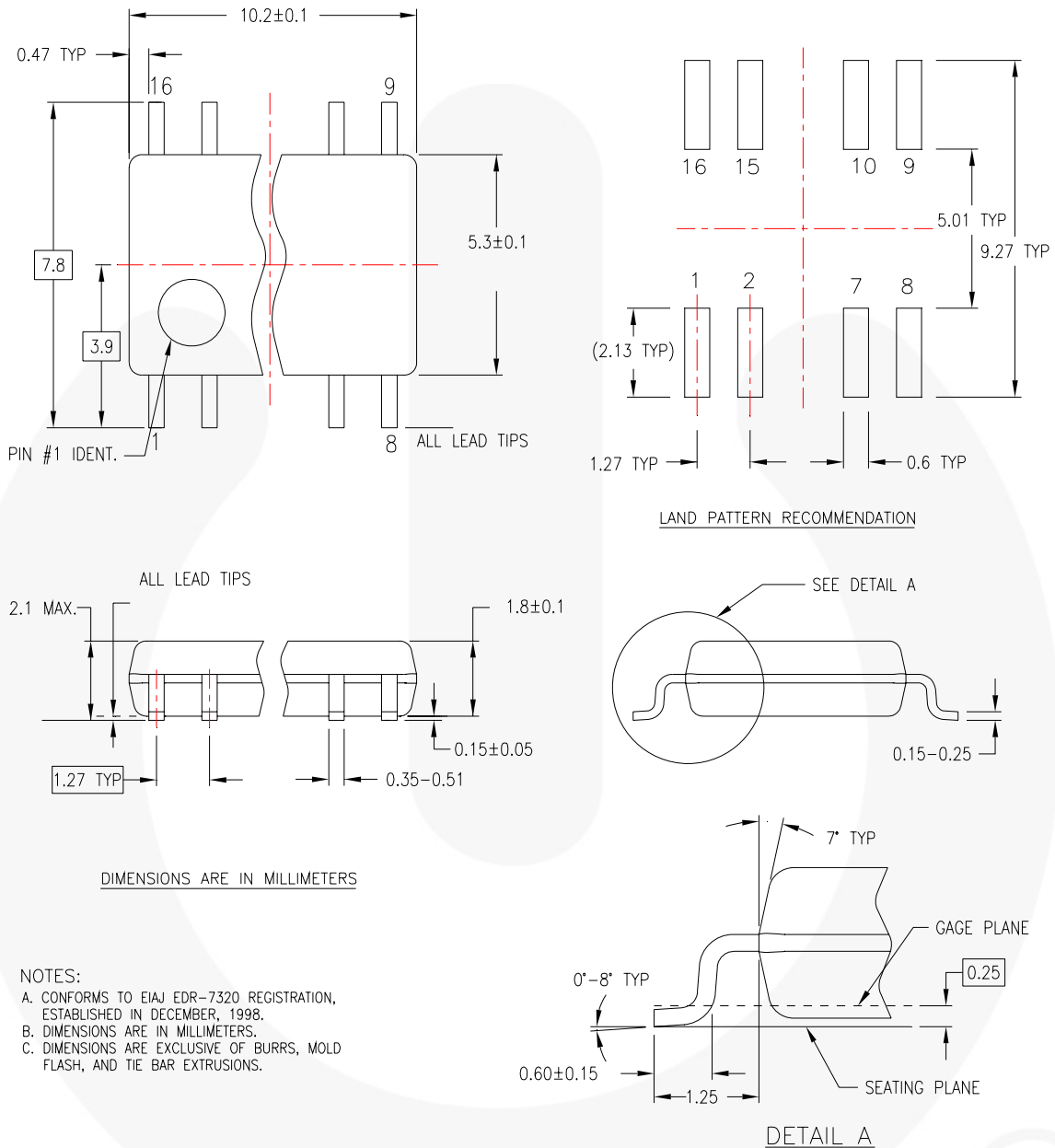

Figure 4. 16-Lead, Small Outline Integrated Circuit (SOIC), JEDEC MS-012, 0.150 Inch Narrow

Package drawings are provided as a service to customers considering Fairchild components. Drawings may change in any manner without notice. Please note the revision and/or date on the drawing and contact a Fairchild Semiconductor representative to verify or obtain the most recent revision. Package specifications do not expand the terms of Fairchild's worldwide terms and conditions, specifically the warranty therein, which covers Fairchild products.

Always visit Fairchild Semiconductor's online packaging area for the most recent package drawings:
<http://www.fairchildsemi.com/packaging/>

Physical Dimensions



M16DREVC

Figure 5. 16-Lead, Small Outline Package (SOP), EIAJ TYPE II, 5.3mm Wide

Package drawings are provided as a service to customers considering Fairchild components. Drawings may change in any manner without notice. Please note the revision and/or date on the drawing and contact a Fairchild Semiconductor representative to verify or obtain the most recent revision. Package specifications do not expand the terms of Fairchild's worldwide terms and conditions, specifically the warranty therein, which covers Fairchild products.

Always visit Fairchild Semiconductor's online packaging area for the most recent package drawings:
<http://www.fairchildsemi.com/packaging/>

Physical Dimensions

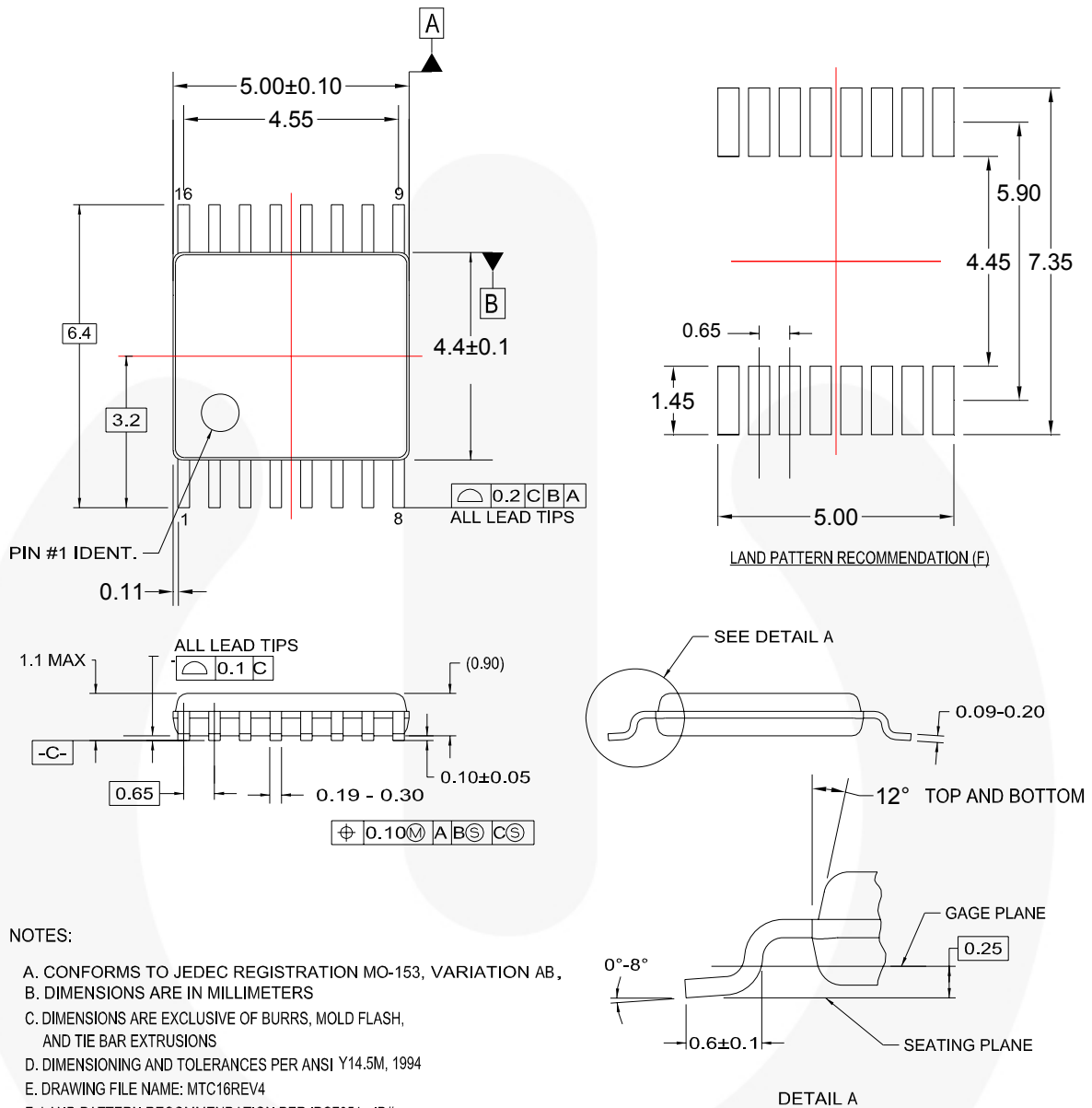

NOTES:

- A. CONFORMS TO JEDEC REGISTRATION MO-153, VARIATION AB,
- B. DIMENSIONS ARE IN MILLIMETERS
- C. DIMENSIONS ARE EXCLUSIVE OF BURRS, MOLD FLASH, AND TIE BAR EXTRUSIONS
- D. DIMENSIONING AND TOLERANCES PER ANSI Y14.5M, 1994
- E. DRAWING FILE NAME: MTC16REV4
- F. LAND PATTERN RECOMMENDATION PER IPC7351 - ID# TSOP65P640X110-16N

MTC16rev4

Figure 6. 16-Lead, Thin Shrink Small Outline Package (TSSOP), JEDEC MO-153, 4.4mm Wide

Package drawings are provided as a service to customers considering Fairchild components. Drawings may change in any manner without notice. Please note the revision and/or date on the drawing and contact a Fairchild Semiconductor representative to verify or obtain the most recent revision. Package specifications do not expand the terms of Fairchild's worldwide terms and conditions, specifically the warranty therein, which covers Fairchild products.

Always visit Fairchild Semiconductor's online packaging area for the most recent package drawings:
<http://www.fairchildsemi.com/packaging/>

Physical Dimensions

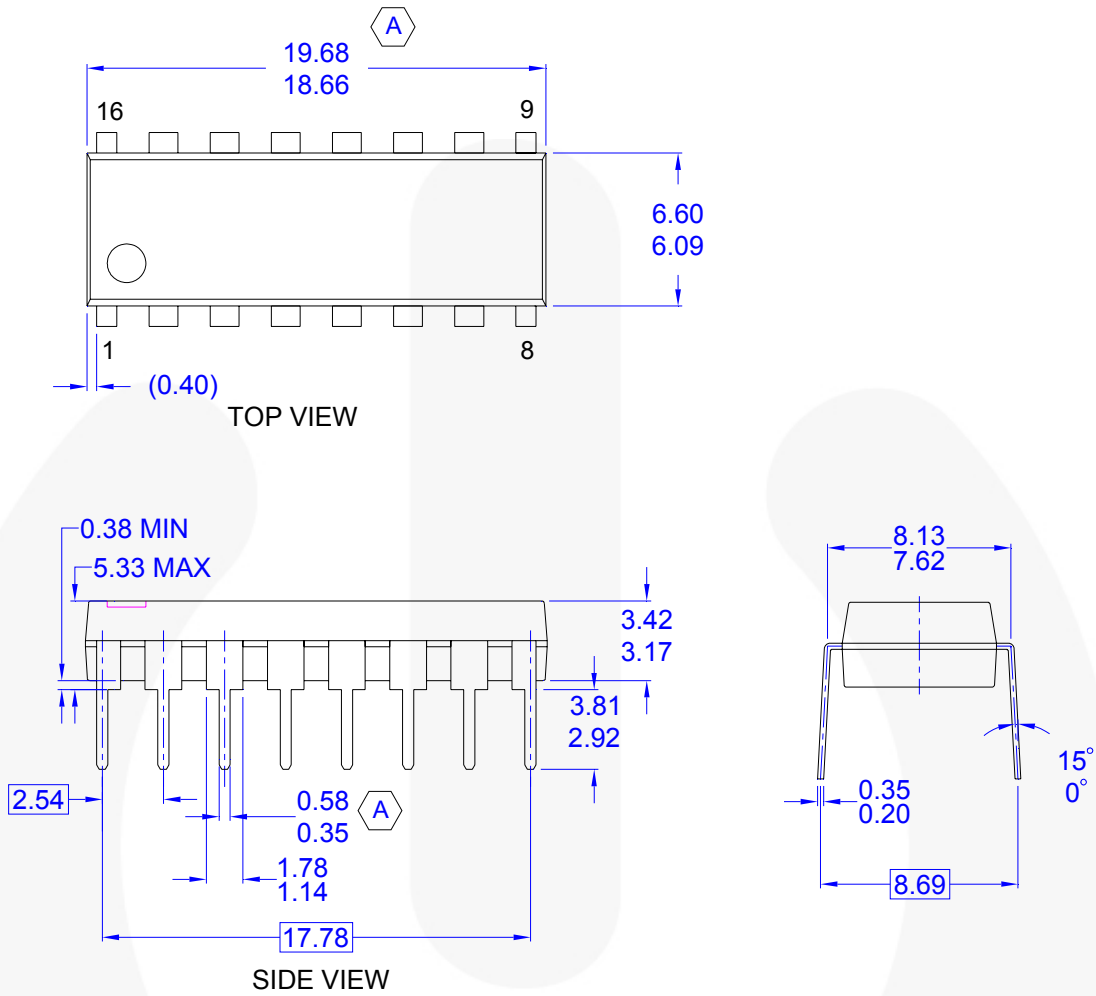

NOTES: UNLESS OTHERWISE SPECIFIED

- A) THIS PACKAGE CONFORMS TO JEDEC MS-001 VARIATION BB
- B) ALL DIMENSIONS ARE IN MILLIMETERS.
- C) DIMENSIONS ARE EXCLUSIVE OF BURRS, MOLD FLASH, AND TIE BAR PROTRUSIONS
- D) CONFORMS TO ASME Y14.5M-1994
- E) DRAWING FILE NAME: N16EREV1

Figure 7. 16-Lead, Plastic Dual In-Line Package (PDIP), JEDEC MS-001, 0.300 Inch Wide







Package drawings are provided as a service to customers considering Fairchild components. Drawings may change in any manner without notice. Please note the revision and/or date on the drawing and contact a Fairchild Semiconductor representative to verify or obtain the most recent revision. Package specifications do not expand the terms of Fairchild's worldwide terms and conditions, specifically the warranty therein, which covers Fairchild products.

Always visit Fairchild Semiconductor's online packaging area for the most recent package drawings:
<http://www.fairchildsemi.com/packaging/>



TRADEMARKS

The following includes registered and unregistered trademarks and service marks, owned by Fairchild Semiconductor and/or its global subsidiaries, and is not intended to be an exhaustive list of all such trademarks.

- | | | | |
|---|---|---|---|
| Auto-SPM™ | F-PFST™ | PowerTrench® | The Power Franchise® |
| Build it Now™ | FRFET® | PowerXS™ | power franchise |
| CorePLUS™ | Global Power Resource SM | Programmable Active Droop™ | TinyBoost™ |
| CorePOWER™ | Green FPS™ | QFET® | TinyBuck™ |
| CROSSVOLT™ | Green FPST™ e-Series™ | QST™ | TinyLogic® |
| CTL™ | Gmax™ | Quiet Series™ | TINYOPTO™ |
| Current Transfer Logic™ | GTO™ | RapidConfigure™ | TinyPower™ |
| EcoSPARK® | IntelliMAX™ |  ™ | TinyPWM™ |
| EfficientMax™ | ISOPLANAR™ | Saving our world, 1mW/W/kW at a time™ | TinyWire™ |
| EZSWITCH™ | MegaBuck™ | SmartMax™ | TriFault Detect™ |
|  ™ | MICROCOUPLER™ | SMART START™ | TRUECURRENT™ |
|  ™ | MicroFET™ | SPM® | μSerDes™ |
| Fairchild® | MicroPak™ | STEALTH™ |  ™ |
| Fairchild Semiconductor® | MillerDrive™ | SuperFET™ | UHC® |
| FACT Quiet Series™ | MotionMax™ | SuperSOT™.3 | Ultra FRFET™ |
| FACT® | Motion-SPM™ | SuperSOT™.6 | UniFET™ |
| FAST® | OPTOLOGIC® | SuperSOT™.8 | VCX™ |
| FastvCore™ | OPTOPLANAR® | SupreMOS™ | VisualMax™ |
| FETBench™ |  ™ | SyncFET™ | XST™ |
| FlashWriter® | PDP SPM™ | Sync-Lock™ | |
| FPS™ | Power-SPM™ |  ™ | |

* Trademarks of System General Corporation, used under license by Fairchild Semiconductor.

DISCLAIMER

FAIRCHILD SEMICONDUCTOR RESERVES THE RIGHT TO MAKE CHANGES WITHOUT FURTHER NOTICE TO ANY PRODUCTS HEREIN TO IMPROVE RELIABILITY, FUNCTION, OR DESIGN. FAIRCHILD DOES NOT ASSUME ANY LIABILITY ARISING OUT OF THE APPLICATION OR USE OF ANY PRODUCT OR CIRCUIT DESCRIBED HEREIN. NEITHER DOES IT CONVEY ANY LICENSE UNDER ITS PATENT RIGHTS, NOR THE RIGHTS OF OTHERS. THESE SPECIFICATIONS DO NOT EXPAND THE TERMS OF FAIRCHILD'S WORLDWIDE TERMS AND CONDITIONS, SPECIFICALLY THE WARRANTY THEREIN, WHICH COVERS THESE PRODUCTS.

LIFE SUPPORT POLICY

FAIRCHILD'S PRODUCTS ARE NOT AUTHORIZED FOR USE AS CRITICAL COMPONENTS IN LIFE SUPPORT DEVICES OR SYSTEMS WITHOUT THE EXPRESS WRITTEN APPROVAL OF FAIRCHILD SEMICONDUCTOR CORPORATION.

As used herein:

1. Life support devices or systems are devices or systems which, (a) are intended for surgical implant into the body or (b) support or sustain life, and (c) whose failure to perform when properly used in accordance with instructions for use provided in the labeling, can be reasonably expected to result in a significant injury of the user.
2. A critical component in any component of a life support, device, or system whose failure to perform can be reasonably expected to cause the failure of the life support device or system, or to affect its safety or effectiveness.

ANTI-COUNTERFEITING POLICY

Fairchild Semiconductor Corporation's Anti-Counterfeiting Policy. Fairchild's Anti-Counterfeiting Policy is also stated on our external website, www.fairchildsemi.com, under Sales Support.

Counterfeiting of semiconductor parts is a growing problem in the industry. All manufacturers of semiconductor products are experiencing counterfeiting of their parts. Customers who inadvertently purchase counterfeit parts experience many problems such as loss of brand reputation, substandard performance, failed applications, and increased cost of production and manufacturing delays. Fairchild is taking strong measures to protect ourselves and our customers from the proliferation of counterfeit parts. Fairchild strongly encourages customers to purchase Fairchild parts either directly from Fairchild or from Authorized Fairchild Distributors who are listed by country on our web page cited above. Products customers buy either from Fairchild directly or from Authorized Fairchild Distributors are genuine parts, have full traceability, meet Fairchild's quality standards for handling and storage and provide access to Fairchild's full range of up-to-date technical and product information. Fairchild and our Authorized Distributors will stand behind all warranties and will appropriately address any warranty issues that may arise. Fairchild will not provide any warranty coverage or other assistance for parts bought from Unauthorized Sources. Fairchild is committed to combat this global problem and encourage our customers to do their part in stopping this practice by buying direct or from authorized distributors.

PRODUCT STATUS DEFINITIONS

Definition of Terms

Datasheet Identification	Product Status	Definition
Advance Information	Formative / In Design	Datasheet contains the design specifications for product development. Specifications may change in any manner without notice.
Preliminary	First Production	Datasheet contains preliminary data; supplementary data will be published at a later date. Fairchild Semiconductor reserves the right to make changes at any time without notice to improve design.
No Identification Needed	Full Production	Datasheet contains final specifications. Fairchild Semiconductor reserves the right to make changes at any time without notice to improve the design.
Obsolete	Not In Production	Datasheet contains specifications on a product that is discontinued by Fairchild Semiconductor. The datasheet is for reference information only.

Rev. 140

ON Semiconductor and  are trademarks of Semiconductor Components Industries, LLC dba ON Semiconductor or its subsidiaries in the United States and/or other countries. ON Semiconductor owns the rights to a number of patents, trademarks, copyrights, trade secrets, and other intellectual property. A listing of ON Semiconductor's product/patent coverage may be accessed at www.onsemi.com/site/pdf/Patent-Marking.pdf. ON Semiconductor reserves the right to make changes without further notice to any products herein. ON Semiconductor makes no warranty, representation or guarantee regarding the suitability of its products for any particular purpose, nor does ON Semiconductor assume any liability arising out of the application or use of any product or circuit, and specifically disclaims any and all liability, including without limitation special, consequential or incidental damages. Buyer is responsible for its products and applications using ON Semiconductor products, including compliance with all laws, regulations and safety requirements or standards, regardless of any support or applications information provided by ON Semiconductor. "Typical" parameters which may be provided in ON Semiconductor data sheets and/or specifications can and do vary in different applications and actual performance may vary over time. All operating parameters, including "Typicals" must be validated for each customer application by customer's technical experts. ON Semiconductor does not convey any license under its patent rights nor the rights of others. ON Semiconductor products are not designed, intended, or authorized for use as a critical component in life support systems or any FDA Class 3 medical devices or medical devices with a same or similar classification in a foreign jurisdiction or any devices intended for implantation in the human body. Should Buyer purchase or use ON Semiconductor products for any such unintended or unauthorized application, Buyer shall indemnify and hold ON Semiconductor and its officers, employees, subsidiaries, affiliates, and distributors harmless against all claims, costs, damages, and expenses, and reasonable attorney fees arising out of, directly or indirectly, any claim of personal injury or death associated with such unintended or unauthorized use, even if such claim alleges that ON Semiconductor was negligent regarding the design or manufacture of the part. ON Semiconductor is an Equal Opportunity/Affirmative Action Employer. This literature is subject to all applicable copyright laws and is not for resale in any manner.

PUBLICATION ORDERING INFORMATION

LITERATURE FULFILLMENT:



Literature Distribution Center for ON Semiconductor
19521 E. 32nd Pkwy, Aurora, Colorado 80011 USA
Phone: 303-675-2175 or 800-344-3860 Toll Free USA/Canada
Fax: 303-675-2176 or 800-344-3867 Toll Free USA/Canada
Email: orderlit@onsemi.com

N. American Technical Support: 800-282-9855 Toll Free
USA/Canada
Europe, Middle East and Africa Technical Support:
Phone: 421 33 790 2910
Japan Customer Focus Center
Phone: 81-3-5817-1050

ON Semiconductor Website: www.onsemi.com
Order Literature: <http://www.onsemi.com/orderlit>
For additional information, please contact your local
Sales Representative

Looking for pricing, stock, or lifecycle information?

Click below to explore more details on WIN SOURCE:

-  [View MM74HC595SJX on WIN SOURCE](#)
-  [Fairchild/ON Semiconductor Information](#)

Optimize Your Supply Chain with WIN SOURCE Solutions

-  Global Sourcing Solution
-  Obsolete Management
-  Cost Control Management
-  Shortage Management
-  Alternative Solution
-  Excess Inventory Management