

## 98 dB, 96 kHz, Multi-Bit Audio A/D Converter

### Features

- ◆ Advanced Multi-Bit  $\Delta\Sigma$  Architecture
- ◆ 24-bit Conversion
- ◆ Supports Audio Sample Rates Up to 108 kHz
- ◆ 98 dB Dynamic Range at 5 V
- ◆ -92 dB THD+N at 5 V
- ◆ Low-Latency Digital Filter
- ◆ High-Pass Filter to Remove DC Offsets
- ◆ Single +3.3 V or +5 V Power Supply
- ◆ Power Consumption < 40 mW at 3.3 V
- ◆ Master or Slave Operation
- ◆ Slave Mode Speed Auto-Detect
- ◆ Master Mode Default Settings
- ◆ 256x or 384x MCLK/LRCK Ratio
- ◆ CS5343 Supports I<sup>2</sup>S Audio Format
- ◆ CS5344 Supports Left-Justified Audio Format

### General Description

The CS5343/4 is a complete analog-to-digital converter for digital audio systems. It performs sampling, analog-to-digital conversion, and anti-alias filtering, generating 24-bit values for both left and right inputs in serial form at sample rates up to 108 kHz per channel.

The CS5343/4 uses a 3rd-order, multi-bit Delta-Sigma modulator followed by a digital filter, which removes the need for an external anti-alias filter.

The CS5343/4 also features a high-impedance sampling network which eliminates costly external components such as op-amps.

The CS5343/4 is available in a 10-pin TSSOP package for both Commercial (-40° to +85° C) and Automotive grades (-40° to +105° C). The CDB5343 Customer Demonstration Board is also available for device evaluation and implementation suggestions. Please refer to the “[Ordering Information](#)” on [page 19](#) for complete details.

The CS5343/4 is ideal for audio systems requiring wide dynamic range, negligible distortion and low noise, such as set-top boxes, DVD-karaoke players, DVD recorders, A/V receivers, and automotive applications.

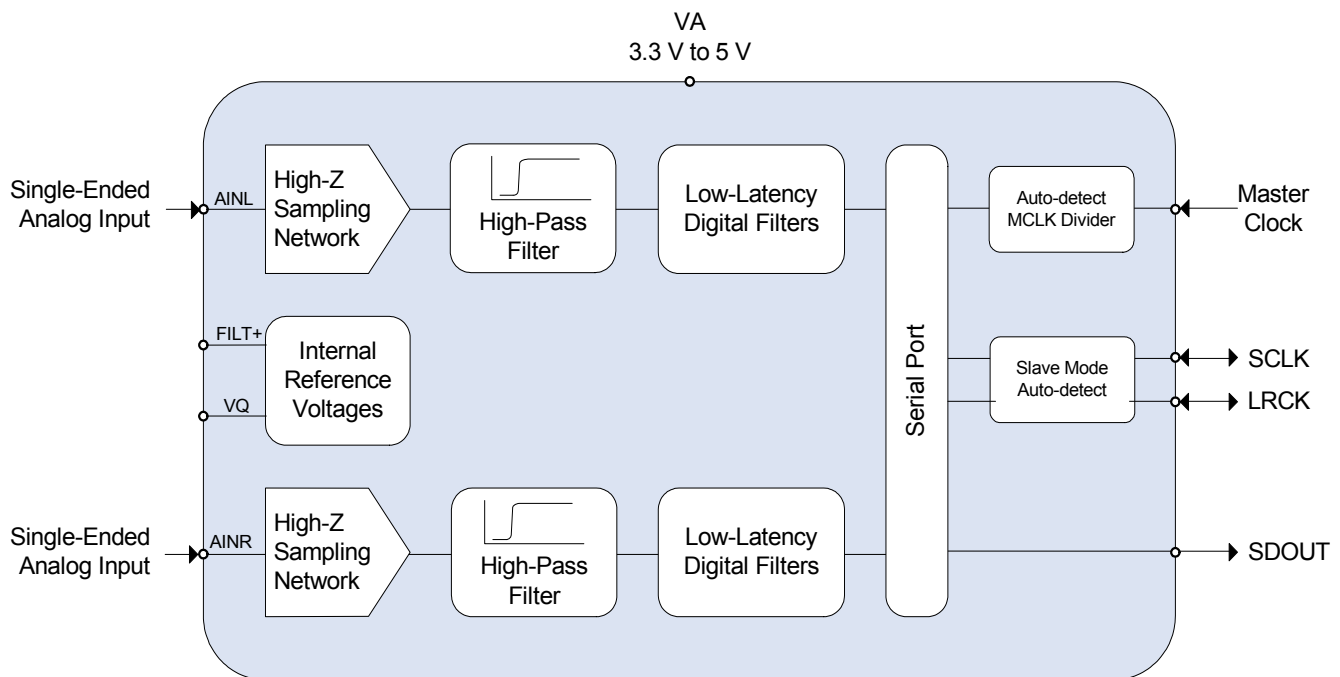

---

**TABLE OF CONTENTS**

<b>1. PIN DESCRIPTIONS</b> .....	<b>3</b>
<b>2. CHARACTERISTICS AND SPECIFICATIONS</b> .....	<b>4</b>
RECOMMENDED OPERATING CONDITIONS .....	4
ABSOLUTE MAXIMUM RATINGS .....	4
ANALOG CHARACTERISTICS - COMMERCIAL GRADE (-CZZ) .....	5
ANALOG CHARACTERISTICS - AUTOMOTIVE GRADE (-DZZ) .....	6
DIGITAL FILTER CHARACTERISTICS .....	7
DC ELECTRICAL CHARACTERISTICS .....	7
DIGITAL CHARACTERISTICS .....	8
SYSTEM CLOCKING AND SERIAL AUDIO INTERFACE .....	9
<b>3. TYPICAL CONNECTION DIAGRAM</b> .....	<b>11</b>
<b>4. APPLICATIONS</b> .....	<b>12</b>
4.1 Operation as Clock Master or Slave .....	12
4.1.1 Slave Mode Operation .....	12
4.1.2 Master Mode Operation .....	13
4.1.2.1 Master Mode Speed Selection .....	13
4.1.3 Master Clock .....	13
4.2 Serial Audio Interface .....	14
4.3 Digital Interface .....	14
4.4 Analog Connections .....	14
4.4.1 Component Values .....	15
4.5 Grounding and Power Supply Decoupling .....	15
4.6 Synchronization of Multiple Devices .....	16
<b>5. FILTER PLOTS - ALL SPEED MODES</b> .....	<b>16</b>
<b>6. PARAMETER DEFINITIONS</b> .....	<b>17</b>
<b>7. PACKAGE DIMENSIONS</b> .....	<b>18</b>
THERMAL CHARACTERISTICS .....	18
<b>8. ORDERING INFORMATION</b> .....	<b>19</b>
<b>9. REVISION HISTORY</b> .....	<b>20</b>

## 1. PIN DESCRIPTIONS

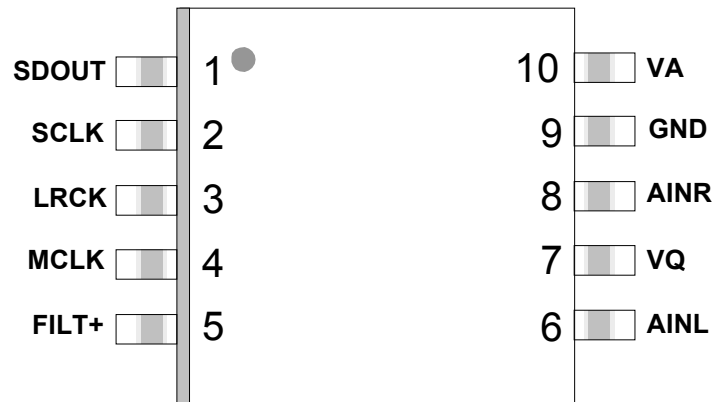

Pin Name	Pin #	Pin Description
SDOUT	1	<b>Serial Audio Data Output</b> ( <i>Output</i> ) - Output for two's complement serial audio data. Also selects Master or Slave Mode; See <a href="#">Section 4.1 on page 12</a> for details.
SCLK	2	<b>Serial Clock</b> ( <i>Input/Output</i> ) - Serial clock for the serial audio interface.
LRCK	3	<b>Left Right Clock</b> ( <i>Input/Output</i> ) - Determines which channel, Left or Right, is currently active on the serial audio data line.
MCLK	4	<b>Master Clock</b> ( <i>Input</i> ) - Clock source for the delta-sigma modulator and digital filters.
FILT+	5	<b>Positive Voltage Reference</b> ( <i>Output</i> ) - Positive reference voltage for the internal sampling circuits.
AINL AINR	6 8	<b>Analog Input</b> ( <i>Input</i> ) - The full-scale analog input level is specified in the Analog Characteristics specification table.
VQ	7	<b>Quiescent Voltage</b> ( <i>Output</i> ) - Filter connection for the internal quiescent reference voltage.
GND	9	<b>Ground</b> ( <i>Input</i> ) - Ground reference. Must be connected to analog ground.
VA	10	<b>Power</b> ( <i>Input</i> ) - Positive power supply for the digital and analog sections.

## 2. CHARACTERISTICS AND SPECIFICATIONS

### RECOMMENDED OPERATING CONDITIONS

GND = 0 V, all voltages with respect to GND.

Parameter	Symbol	Min	Typ	Max	Unit	
Power Supplies	VA	3.1	3.3	3.5	V	
		4.75	5.0	5.25	V	
Ambient Operating Temperature	Commercial (-CZZ)	$T_{AC}$	-40	-	85	°C
	Automotive (-DZZ)	$T_{AD}$	-40	-	105	°C

### ABSOLUTE MAXIMUM RATINGS

GND = 0 V, all voltages with respect to GND. (Note 1)

Parameter	Symbol	Min	Max	Unit
DC Power Supplies	VA	-0.3	+6.0	V
Input Current (Note 2)	$I_{in}$	-10	+10	mA
Input Voltage (Note 3)	$V_{IN}$	-0.7	VA+0.7	V
Ambient Operating Temperature (Power Applied)	$T_A$	-50	+115	°C
Storage Temperature	$T_{stg}$	-65	+150	°C

#### Notes:

1. Operation beyond these limits may result in permanent damage to the device. Normal operation is not guaranteed at these extremes.
2. Any pin except supplies. Transient currents of up to  $\pm 100$  mA on the analog input pins will not cause SCR latch-up.
3. The maximum over/under voltage is limited by the input current.

## ANALOG CHARACTERISTICS - COMMERCIAL GRADE (-CZZ)

Test conditions (unless otherwise specified):  $T_A = 25^\circ\text{C}$ ; Input test signal is a 997 Hz sine wave through recommended inputs as seen in [Figure 6 on page 14](#); source impedance less than or equal to 2.5 k $\Omega$ ; valid with FILT+ and VQ components as shown in [Figure 3 on page 11](#); measurement bandwidth is 10 Hz to 20 kHz;  $F_s = 48\text{ kHz}$  or 96 kHz.

<b>Dynamic Performance for Commercial Grade</b>			<b>VA = 3.3 V</b>			<b>VA = 5.0 V</b>			
	Symbol		Min	Typ	Max	Min	Typ	Max	Unit
Dynamic Range	A-weighted		91	94	-	95	98	-	dB
	unweighted		88	91	-	92	95	-	dB
Total Harmonic Distortion + Noise	(Note 4)								
	-1 dB	THD+N	-	-89	-86	-	-92	-89	dB
	-20 dB		-	-71	-	-	-75	-	dB
	-60 dB		-	-31	-	-	-35	-	dB
<b>Dynamic Performance for Commercial Grade</b>			<b>VA = 3.3 V and VA = 5.0 V</b>						
			Min	Typ	Max	Min	Typ	Max	Unit
Interchannel Isolation			-	90	-				dB
<b>DC Accuracy</b>									
Interchannel Gain Mismatch			-	-	-	0.1			dB
Gain Error			-3	-	-	+3			%
Gain Drift			-	$\pm 100$	-	-			ppm/ $^\circ\text{C}$
<b>Analog Input Characteristics</b>									
Full-scale Input Voltage	VA = 3.3 V nom		0.560*VA	0.568*VA	0.575*VA				Vpp
Full-scale Input Voltage	VA = 5 V nom		0.552*VA	0.559*VA	0.567*VA				Vpp
Input Impedance			-	7.5	-				M $\Omega$

### Notes:

4. Referred to the typical full-scale input voltage

## ANALOG CHARACTERISTICS - AUTOMOTIVE GRADE (-DZZ)

Test conditions (unless otherwise specified):  $T_A = -40^\circ\text{C}$  to  $85^\circ\text{C}$ ; Input test signal is a 997 Hz sine wave through recommended inputs as seen in [Figure 6 on page 14](#); source impedance less than or equal to 2.5 k $\Omega$ ; valid with FILT+ and VQ components as shown in [Figure 3 on page 11](#); measurement bandwidth is 10 Hz to 20 kHz;  $F_s = 48\text{ kHz}$  or  $96\text{ kHz}$ .

<b>Dynamic Performance for Automotive Grade</b>			<b>VA = 3.1 to 3.5 V</b>			<b>VA = 4.75 to 5.25 V</b>			
	Symbol		Min	Typ	Max	Min	Typ	Max	Unit
Dynamic Range	A-weighted		86	94	-	90	98	-	dB
	unweighted		83	91	-	87	95	-	dB
Total Harmonic Distortion + Noise	(Note 5)								
	-1 dB	THD+N	-	-88	-76	-	-91	-84	dB
	-20 dB		-	-71	-	-	-75	-	dB
	-60 dB		-	-31	-	-	-35	-	dB
<b>Dynamic Performance for Automotive Grade</b>			<b>VA = 3.1 V to 3.5 V and VA = 4.75 V to 5.25 V</b>						
			Min	Typ	Max				Unit
Interchannel Isolation			-	90	-				dB
<b>DC Accuracy</b>									
Interchannel Gain Mismatch			-	-	0.1				dB
Gain Error			-3	-	+3				%
Gain Drift			-	$\pm 100$	-				ppm/ $^\circ\text{C}$
<b>Analog Input Characteristics</b>									
Full-scale Input Voltage	VA = 3.1 V to 3.5 V		0.523*VA	0.567*VA	0.612*VA				V <sub>pp</sub>
Full-scale Input Voltage	VA = 4.75 V to 5.25 V		0.543*VA	0.560*VA	0.573*VA				V <sub>pp</sub>
Input Impedance			-	7.5	-				M $\Omega$

### Notes:

5. Referred to the typical full-scale input voltage

## DIGITAL FILTER CHARACTERISTICS

Parameter	Symbol	Min	Typ	Max	Unit
<b>All Speed Modes</b>					
Passband (-0.1 dB)		0	-	0.489	Fs
Passband Ripple		-0.031	-	0.031	dB
Stopband		0.560	-	-	Fs
Stopband Attenuation		60	-	-	dB
Total Group Delay (Fs = Output Sample Rate)	$t_{gd}$	-	12/Fs	-	s
<b>High-Pass Filter Characteristics</b>					
Frequency Response	-3.0 dB	-	1	-	Hz
	-0.13 dB (Note 6)		20	-	Hz
Phase Deviation	@ 20 Hz (Note 6)	-	10	-	Deg
Passband Ripple		-	-	0	dB

### Notes:

6. Response shown is for Fs equal to 48 kHz. Filter characteristics scale with Fs.

## DC ELECTRICAL CHARACTERISTICS

GND = 0 V, all voltages with respect to 0 V. MCLK=12.288 MHz; Master Mode.

Parameter	Symbol	VA = 3.3 V			VA = 5.0 V			Unit
		Min	Typ	Max	Min	Typ	Max	
Power Supply Current (Normal Operation)	$I_A$	-	11	15	-	12	17	mA
Power Supply Current (Power-Down Mode) (Note 7)	$I_A$	-	10	-	-	40	-	uA
Power Consumption (Normal Operation)	-	-	36	50	-	60	85	mW
Power Consumption (Power-Down Mode) (Note 7)	-	-	<1	-	-	<1	-	mW
Parameter	Symbol	Min	Typ	Max	Unit			
Power Supply Rejection Ratio (1 kHz) (Note 8)	PSRR	-	65	-	dB			
V <sub>Q</sub> Nominal Voltage		-	0.44xVA	-	V			
Output Impedance		-	25	-	kΩ			
Filt+ Nominal Voltage		-	VA	-	V			
Output Impedance		-	220	-	kΩ			
Maximum allowable DC current source/sink		-	2.5	-	uA			

### Notes:

7. Device enters power-down mode when MCLK is held static.
8. Valid with the recommended capacitor values on FILT+ and VQ as shown in the Typical Connection Diagram.

**DIGITAL CHARACTERISTICS**

Parameter	Symbol	Min	Typ	Max	Units
High-Level Input Voltage (% of VA)	$V_{IH}$	60	-	-	%
Low-Level Input Voltage (% of VA)	$V_{IL}$	-	-	30	%
High-Level Output Voltage at $I_o = 500 \mu A$ (% of VA)	$V_{OH}$	70	-	-	%
Low-Level Output Voltage at $I_o = 500 \mu A$ (% of VA)	$V_{OL}$	-	-	15	%
Input Leakage Current	$I_{in}$	-10	-	10	$\mu A$

**SYSTEM CLOCKING AND SERIAL AUDIO INTERFACE**

 Logic "0" = GND = 0 V; Logic "1" = VA, C<sub>L</sub> = 20 pF.

Parameter		Symbol	Min	Typ	Max	Unit
<b>Master Mode</b>						
MCLK Period	(Double-Speed, 384x Mode)	t <sub>clkw</sub>	24	-	30	ns
	(Double-Speed, 192x Mode)		48	-	60	ns
	(Double-Speed, 256x Mode)		36	-	45	ns
	(Double-Speed, 128x Mode)		72	-	90	ns
	(Single-Speed, 768x Mode)		24	-	30	ns
	(Single-Speed, 384x Mode)		48	-	60	ns
	(Single-Speed, 384x Mode)		108	-	651	ns
	(Single-Speed, 512x Mode)		36	-	45	ns
	(Single-Speed, 256x Mode)		72	-	90	ns
(Single-Speed, 256x Mode)	162	-	977	ns		
MCLK Duty Cycle			40	50	60	%
Output Sample Rate	(Single-Speed)	Fs	4	-	24	kHz
	(Single-Speed)		43	-	54	kHz
	(Double-Speed)		86	-	108	kHz
LRCK Duty Cycle			-	50	-	%
SCLK Duty Cycle			-	50	-	%
SDOUT valid before SCLK rising		t <sub>stp</sub>	10	-	-	ns
SDOUT valid after SCLK rising		t <sub>hld</sub>	40	-	-	ns
SCLK falling to LRCK edge		t <sub>slrd</sub>	-20	-	20	ns
<b>Slave Mode</b>						
MCLK Period	(Double-Speed, 384x Mode)	t <sub>clkw</sub>	24	-	30	ns
	(Double-Speed, 192x Mode)		48	-	60	ns
	(Double-Speed, 256x Mode)		36	-	45	ns
	(Double-Speed, 128x Mode)		72	-	90	ns
	(Single-Speed, 768x Mode)		24	-	325	ns
	(Single-Speed, 384x Mode)		48	-	651	ns
	(Single-Speed, 512x Mode)		36	-	488	ns
	(Single-Speed, 256x Mode)		72	-	976	ns
MCLK Duty Cycle			40	50	60	%
Input Sample Rate	(Single-Speed)	Fs	4	-	54	kHz
	(Double-Speed)		86	-	108	kHz
LRCK Duty Cycle			40	50	60	%
SCLK Period		t <sub>sclkw</sub>	$\frac{1}{64 \times F_s}$	-	-	ns
SCLK Duty Cycle			45	50	55	%
SDOUT valid before SCLK rising		t <sub>stp</sub>	10	-	-	ns
SDOUT valid after SCLK rising		t <sub>hld</sub>	40	-	-	ns
SCLK falling to LRCK edge		t <sub>slrd</sub>	-20	-	20	ns

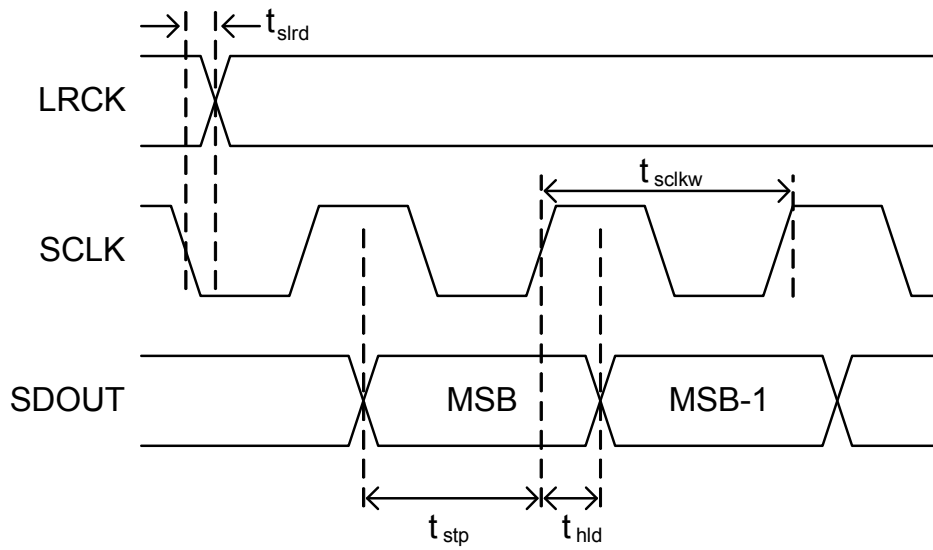

**Figure 1. CS5343 I²S Serial Audio Interface**

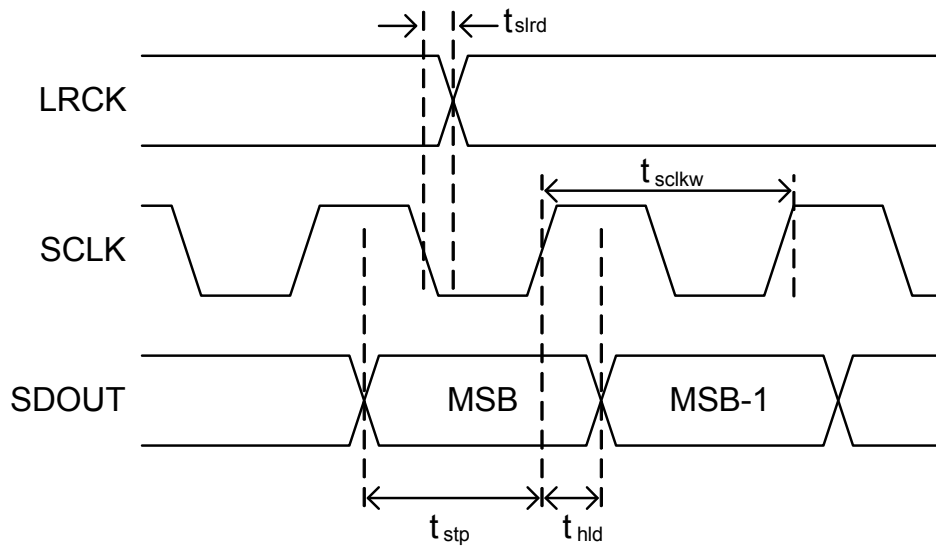

**Figure 2. CS5344 Left-Justified Serial Audio Interface**

### 3. TYPICAL CONNECTION DIAGRAM

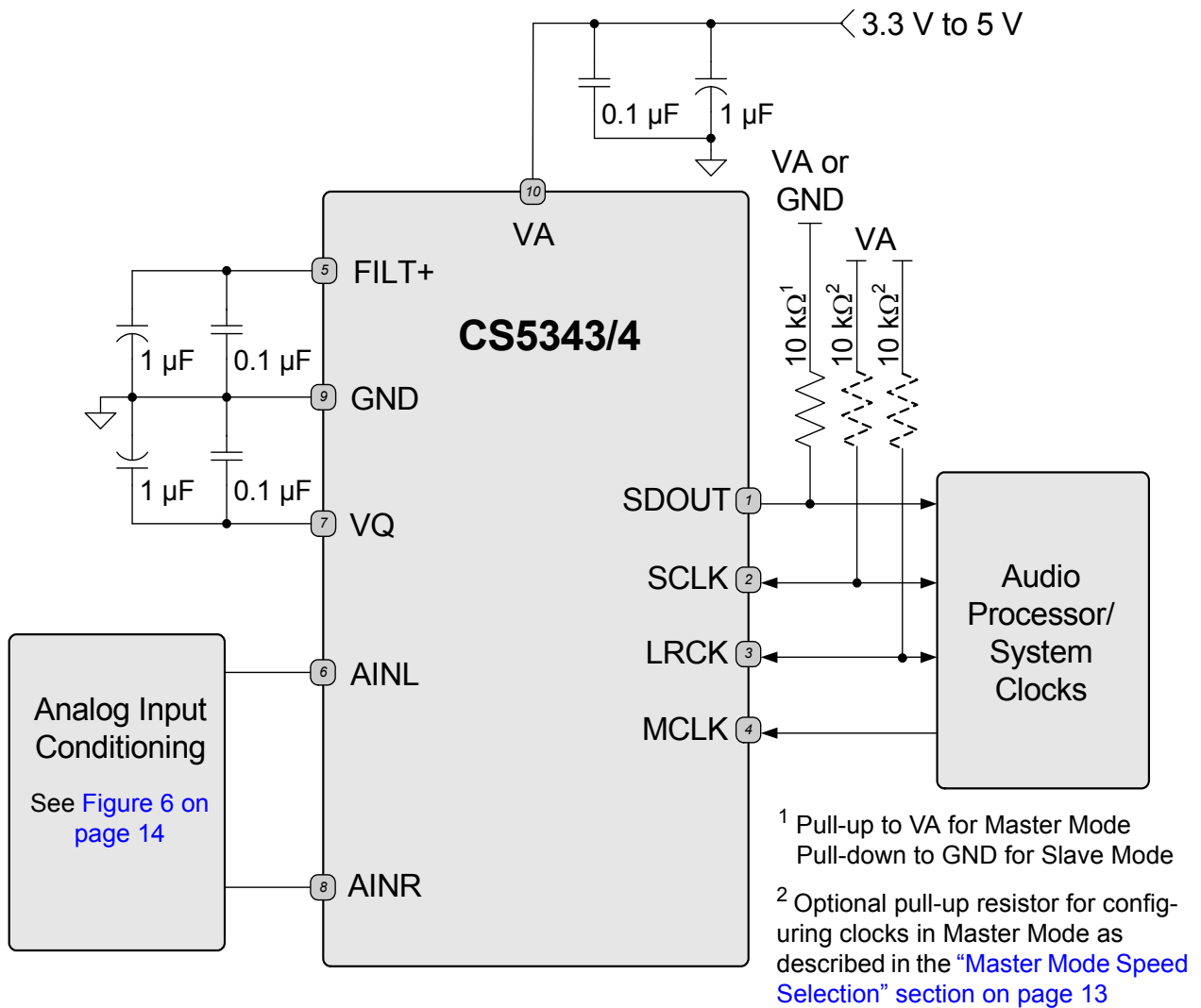

Figure 3. Typical Connection Diagram

## 4. APPLICATIONS

### 4.1 Operation as Clock Master or Slave

The CS5343/4 supports operation as either a clock master or slave. As a clock master, the left/right and serial clocks are synchronously generated on-chip and output on the LRCK and SCLK pins, respectively. As a clock slave, the LRCK and SCLK pins are always inputs and require external generation of the left/right and serial clocks. The selection of clock master or slave is made via a 10 k $\Omega$  pull-up resistor from SDOUT to VA for Master Mode selection or via a 10 k $\Omega$  pull-down resistor from SDOUT to GND for Slave Mode selection, as shown in [Table 1](#).

Mode	Selection
Master Mode	10 k $\Omega$ pull-up resistor from SDOUT to VA
Slave Mode	10 k $\Omega$ pull-down resistor from SDOUT to GND

**Table 1. Master/Slave Mode Selection**

#### 4.1.1 Slave Mode Operation

A unique feature of the CS5343/4 is the automatic selection of either Single- or Double-Speed Mode when acting as a clock slave. The auto-mode selection feature supports all standard audio sample rates from 4 to 108 kHz. Please refer to [Table 2](#) for supported sample rate ranges in Slave Mode.

Speed Mode	MCLK/LRCK Ratio	SCLK/LRCK Ratio	Input Sample Rate Range (kHz)
Single-Speed Mode	256x	64	4 - 54
	512x	64	4 - 54
	384x	48, 64	4 - 54
	768x	48, 64	4 - 54
Double-Speed Mode	128x	64	86 - 108
	256x	64	86 - 108
	192x	48, 64	86 - 108
	384x	48, 64	86 - 108

**Table 2. Speed Modes and the Associated Sample Rates (Fs) in Slave Mode**

### 4.1.2 Master Mode Operation

As clock Master, the CS5343/4 generates LRCK and SCLK synchronously on-chip. Table 3 shows the available sample rates and associated clock ratios in Master Mode.

Speed Mode	MCLK/LRCK Ratio	SCLK/LRCK Ratio	Input Sample Rate Range (kHz)
Single-Speed Mode	256x	64	4 - 24, 43 - 54
	512x	64	43 - 54
	384x	64	4 - 24, 43 - 54
	768x	64	43 - 54
Double-Speed Mode	128x	64	86 - 108
	256x	64	86 - 108
	192x	64	86 - 108
	384x	64	86 - 108

**Table 3. Speed Modes and the Associated Sample Rates (Fs) in Master Mode**

#### 4.1.2.1 Master Mode Speed Selection

During power-up in Master Mode, the LRCK and SCLK pins are inputs to configure speed mode and the output clock ratio. The LRCK pin is pulled low internally to select Single-Speed Mode by default, but Double-Speed Mode is accessed with a 10 kΩ pull-up resistor from LRCK to VA as shown in Table 4. Similarly, the SCLK pin is internally pulled-low by default to select a 256x/512x MCLK/LRCK ratio, but a MCLK/LRCK ratio of 348x/768x is accessed with a 10 kΩ pull-up resistor from SCLK to VA as shown in Table 4. Following the power-up routine, the LRCK and SCLK pins become clock outputs.

Pin	Resistor Option	Clock Configuration
LRCK	Internal Pull-Down to GND (100 kΩ)	Single-Speed Mode (default)
	External Pull-Up to VA (10 kΩ)	Double-Speed Mode
SCLK	Internal Pull-Down to GND (100 kΩ)	128x/256x/512x MCLK/LRCK (default)
	External Pull-Up to VA (10 kΩ)	192x/384x/768x MCLK/LRCK

**Table 4. Speed Mode Selection in Master Mode**

### 4.1.3 Master Clock

The CS5343/4 requires a Master clock (MCLK) which runs the internal sampling circuits and digital filters. There is an internal automatic MCLK divider which is activated based on the input frequency of MCLK. This divider selection allows the high and low MCLK speeds in a given speed mode (i.e. 256x and 512x in SSM). Table 4 lists some common audio output sample rates and the required MCLK frequency.

Master and Slave Mode					
Sample Rate (kHz)	Speed Mode	MCLK(MHz)		MCLK (MHz)	
		256x	512x	384x	768x
32 (*Slave Mode Only)	SSM	*8.192	*16.384	*12.288	*24.576
44.1	SSM	11.289	22.579	16.934	33.868
48	SSM	12.288	24.576	18.432	36.864
Sample Rate (kHz)	Speed Mode	MCLK(MHz)		MCLK (MHz)	
		128x	256x	192x	384x
88.2	DSM	11.289	22.579	16.934	33.868
96	DSM	12.288	24.576	18.432	36.864

**Table 5. Common MCLK Frequencies in Master and Slave Modes**

## 4.2 Serial Audio Interface

The CS5343 output is serial data in I<sup>2</sup>S audio format and the CS5344 output is serial data in Left-Justified audio format. Figures 4 and 5 show the I<sup>2</sup>S and Left-Justified data relative to SCLK and LRCK. Additionally, Figures 1 and 2 display more information on the required timing for the serial audio interface format. For an overview of serial audio interface formats, please refer to Cirrus Application Note AN282.

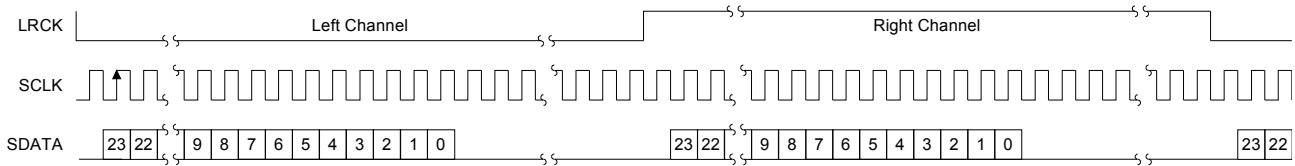

**Figure 4. CS5343 I<sup>2</sup>S Serial Audio Interface**

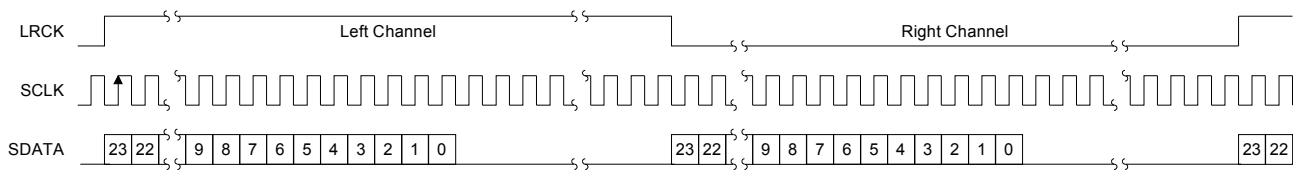

**Figure 5. CS5344 Left-Justified Serial Audio Interface**

## 4.3 Digital Interface

VA supplies power to both the analog and digital sections of the ADC, and also powers the serial port. Consequently, the digital interface logic level must equal VA to within the limits specified under “[Digital Characteristics](#)” on page 8.

## 4.4 Analog Connections

The analog modulator samples the input signal at half of the internal master clock rate, or 6.144 MHz when MCLK = 12.288 MHz. The digital filter will reject signals within the stopband of the filter. However, there is no rejection for input signals which are multiples of the input sampling frequency ( $n \times 6.144$  MHz), where  $n=0,1,2,\dots$ . Refer to Figure 6 which shows the recommended topology of the analog input network. The external shunt capacitor and internal input impedance form a single-pole RC filter to provide the appropriate filtering of noise at the modulator sampling frequency. Additionally, the 180 pF capacitor acts as a charge source for the internal sampling circuits. Capacitors of NPO or other high-quality dielectric will produce the best results while capacitors with a large voltage coefficient (such as general-purpose ceramics) can degrade signal linearity.

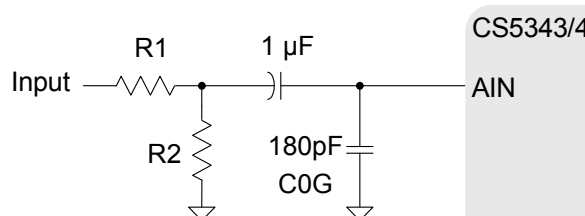

**Figure 6. CS5343/4 Analog Input Network**

### 4.4.1 Component Values

Three parameters determine the values of resistors R1 and R2 as shown in [Figure 6](#): source impedance, attenuation, and input impedance. [Table 6](#) shows the design equation used to determine these values.

- **Source Impedance:** Source impedance is defined as the impedance as seen from the ADC looking back into the signal network. The ADC achieves optimal THD+N performance with a source impedance less than or equal to 2.5 kΩ.
- **Attenuation:** The required attenuation factor depends on the magnitude of the input signal. The full-scale input voltage is specified under “[Analog Characteristics - Commercial Grade \(-CZZ\)](#)” on [page 5](#). The user should select values for R1 and R2 such that the magnitude of the incoming signal multiplied by the attenuation factor is less than or equal to the full-scale input voltage of the device.
- **Input Impedance:** Input impedance is the impedance from the signal source to the ADC analog input pins, including the ADC. Because the ADC’s input impedance (see the “[Analog Characteristics - Commercial Grade \(-CZZ\)](#)” table on [page 5](#)) is several orders of magnitude larger than the resistor values typically used for the input attenuator, its contribution can be neglected when calculating the input impedance. [Table 6](#) shows the input parameters and the associated design equations for the input attenuator.

Source Impedance	$\frac{(R1 \times R2)}{R1 + R2}$
Attenuation Factor	$\frac{(R2)}{(R1 + R2)}$
Input Impedance	$(R1 + R2)$

**Table 6. Analog Input Design Parameters**

[Figure 7](#) illustrates an example configuration using two 4.99 kΩ resistors in place of R1 and R2. Based on the discussion above, this circuit provides an optimal interface for both the ADC and the signal source. First, consumer equipment frequently requires an input impedance of 10 kΩ, which the 4.99 kΩ resistors provide. Second, this circuit will attenuate a typical line level voltage, 2 V<sub>rms</sub>, to the full-scale input of the ADC, 1 V<sub>rms</sub> when V<sub>A</sub> = 5 V. Finally, at 2.5 kΩ, the source impedance optimizes analog performance of the ADC.

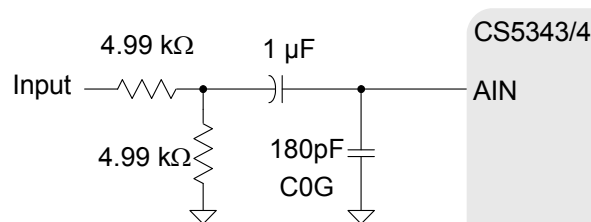

**Figure 7. CS5343/4 Example Analog Input Network**

## 4.5 Grounding and Power Supply Decoupling

As with any high-resolution converter, designing with the CS5343/4 requires careful attention to power supply and grounding arrangements if its potential performance is to be realized. [Figure 3](#) shows the recommended power arrangements, with V<sub>A</sub> connected to a clean supply. Decoupling capacitors should be as near to the ADC as possible, with the low value ceramic capacitor being the nearest. All signals, especially clocks, should be kept away from the FILT+ and VQ pins in order to avoid unwanted coupling into the modulators. The FILT+ and VQ decoupling capacitors, particularly the 0.1 μF, must be positioned to minimize the electrical path from FILT+ to GND. The CDB5343 evaluation board demonstrates the optimum layout and power supply arrangements. To minimize digital noise, connect the ADC digital outputs only to CMOS inputs.

## 4.6 Synchronization of Multiple Devices

In systems where multiple ADCs are required, care must be taken to achieve simultaneous sampling. To ensure synchronous sampling, the MCLK, SCLK, and LRCK signals must be the same for all of the CS5343 and CS5344 devices in the system.

## 5. FILTER PLOTS - ALL SPEED MODES

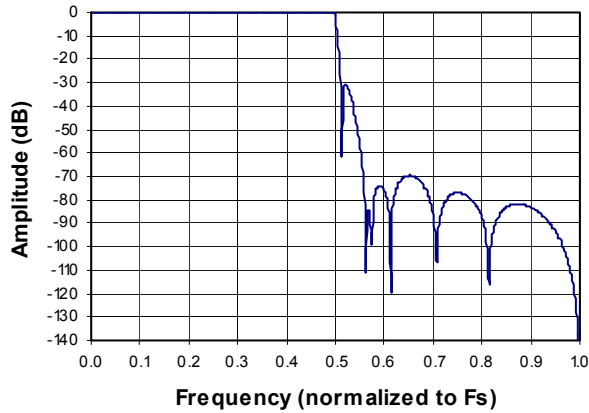

Figure 8. Stopband Rejection

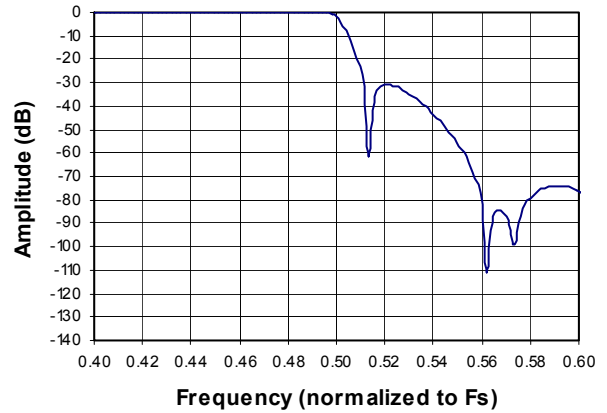

Figure 9. Transition Band

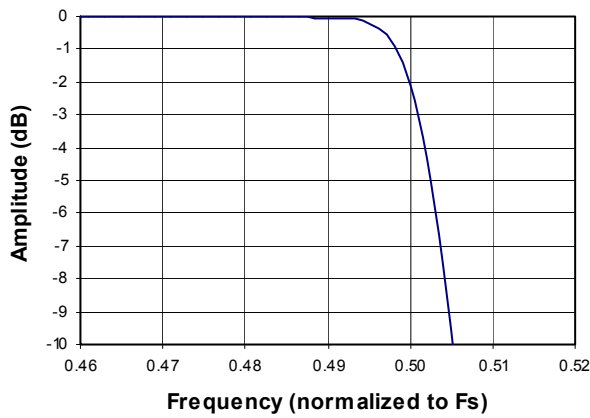

Figure 10. Transition Band (Detail)

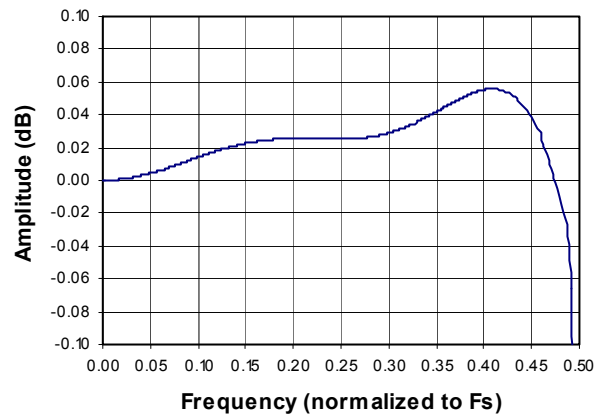

Figure 11. Passband Ripple

---

## **6. PARAMETER DEFINITIONS**

### **Dynamic Range**

The ratio of the rms value of the signal to the rms sum of all other spectral components over the specified bandwidth. Dynamic Range is a signal-to-noise ratio measurement over the specified bandwidth made with a -60 dBFS signal. 60 dB is added to resulting measurement to refer the measurement to full-scale. This technique ensures that the distortion components are below the noise level and do not affect the measurement. This measurement technique has been accepted by the Audio Engineering Society, AES17-1991, and the Electronic Industries Association of Japan, EIAJ CP-307. Expressed in decibels.

### **Total Harmonic Distortion + Noise**

The ratio of the rms value of the signal to the rms sum of all other spectral components over the specified bandwidth (typically 10 Hz to 20 kHz), including distortion components. Expressed in decibels. Measured at -1 and -20 dBFS as suggested in AES17-1991 Annex A.

### **Frequency Response**

A measure of the amplitude response variation from 10 Hz to 20 kHz relative to the amplitude response at 1 kHz. Units in decibels.

### **Interchannel Isolation**

A measure of crosstalk between the left and right channels. Measured for each channel at the converter's output with no signal to the input under test and a full-scale signal applied to the other channel. Units in decibels.

### **Interchannel Gain Mismatch**

The gain difference between left and right channels. Units in decibels.

### **Gain Error**

The deviation from the nominal full-scale analog input for a full-scale digital output.

### **Gain Drift**

The change in gain value with temperature. Units in ppm/°C.

## 7. PACKAGE DIMENSIONS

### 10LD TSSOP (3 mm BODY) PACKAGE DRAWING (Note 1)

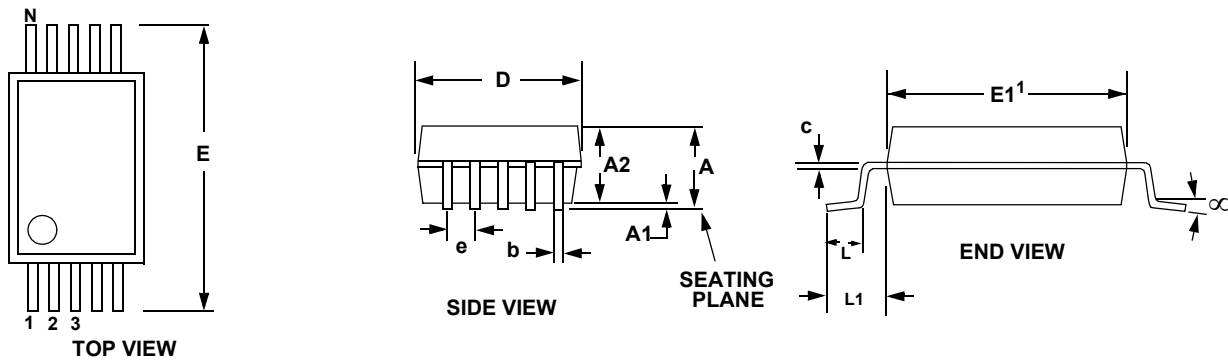

DIM	INCHES			MILLIMETERS			NOTE
	MIN	NOM	MAX	MIN	NOM	MAX	
A	--	--	0.0433	--	--	1.10	
A1	0	--	0.0059	0	--	0.15	
A2	0.0295	--	0.0374	0.75	--	0.95	
b	0.0059	--	0.0118	0.15	--	0.30	4, 5
c	0.0031	--	0.0091	0.08	--	0.23	
D	--	0.1181 BSC	--	--	3.00 BSC	--	2
E	--	0.1929 BSC	--	--	4.90 BSC	--	
E1	--	0.1181 BSC	--	--	3.00 BSC	--	3
e	--	0.0197 BSC	--	--	0.50 BSC	--	
L	0.0157	0.0236	0.0315	0.40	0.60	0.80	
L1	--	0.0374 REF	--	--	0.95 REF	--	
$\mu$	0°	--	8°	0°	--	8°	

Controlling Dimension is Millimeters

#### Notes:

- Reference document: JEDEC MO-187
- D does not include mold flash or protrusions, which is 0.15 mm max. per side.
- E1 does not include inter-lead flash or protrusions, which is 0.15 mm max per side.
- Dimension b does not include a total allowable dambar protrusion of 0.08 mm max.
- Exceptions to JEDEC dimension.

## THERMAL CHARACTERISTICS

Parameter	Symbol	Min	Typ	Max	Unit
Allowable Junction Temperature	$T_J$	-	-	135	°C
Junction to Ambient Thermal Impedance	(4-layer PCB) $\theta_{JA-4}$	-	100	-	°C/W
	(2-layer PCB) $\theta_{JA-2}$	-	170	-	°C/W

**8. ORDERING INFORMATION**

Product	Description	Package	Pb-Free	Grade	Temp Range	Container	Order #
CS5343	98 dB, Multi-Bit Audio A/D Converter, I <sup>2</sup> S Audio Format	10-TSSOP	Yes	Commercial	-40° to +85° C	Rail	CS5343-CZZ
						Tape & Reel	CS5343-CZZR
CS5343	98 dB, Multi-Bit Audio A/D Converter, I <sup>2</sup> S Audio Format	10-TSSOP	Yes	Automotive	-40° to +105° C	Rail	CS5343-DZZ
						Tape & Reel	CS5343-DZZR
CS5344	98 dB, Multi-Bit Audio A/D Converter, Left-Justified Audio Format	10-TSSOP	Yes	Commercial	-40° to +85° C	Rail	CS5344-CZZ
						Tape & Reel	CS5344-CZZR
CS5344	98 dB, Multi-Bit Audio A/D Converter, Left-Justified Audio Format	10-TSSOP	Yes	Automotive	-40° to +105° C	Rail	CS5344-DZZ
						Tape & Reel	CS5344-DZZR
CDB5343	CS5343 Evaluation Board	-	No	-	-	-	CDB5343

## 9. REVISION HISTORY

Release	Changes
F1	Updated <a href="#">“Recommended Operating Conditions”</a> on page 4 Updated specifications and limits for <a href="#">“Analog Characteristics - Commercial Grade (-CZZ)”</a> on page 5 Updated specifications and limits for <a href="#">“Analog Characteristics - Automotive Grade (-DZZ)”</a> on page 6 Corrected <a href="#">“Power Supply Current (Normal Operation)”</a> on page 7 Increased specification for Slave-Mode <a href="#">“SDOUT valid after SCLK rising”</a> on page 9 Corrected <a href="#">Section 4.1.2.1</a> on page 13 Updated <a href="#">Section 4.1.3</a> on page 13
F2	Removed Fs < 43 kHz from master mode operation: -Updated master mode timing specifications in the <a href="#">“System Clocking and Serial Audio Interface”</a> on page 9 -Updated Input Sample Rate Range in <a href="#">Table 3</a> on page 13 -Added note for “slave mode only” for Fs = 32 kHz in <a href="#">Table 5</a> on page 13.
F3	Updated Passband Ripple, Stopband Attenuation and Total Group Delay specs in <a href="#">“Digital Filter Characteristics”</a> on page 7.
F4	Corrected a typographical error in <a href="#">Table 5</a> , <a href="#">“Common MCLK Frequencies in Master and Slave Modes,”</a> on page 13. Changed 8.912 MHz to 8.192 MHz.
F5	Updated master mode MCLK period and output sample rate in <a href="#">“System Clocking and Serial Audio Interface”</a> on page 9. Updated input sample rate range in <a href="#">“Master Mode Operation”</a> on page 13. Updated legal text.

---

## Contacting Cirrus Logic Support

For all product questions and inquiries, contact a Cirrus Logic Sales Representative.

To find one nearest you, go to [www.cirrus.com](http://www.cirrus.com).

---

### IMPORTANT NOTICE

The products and services of Cirrus Logic International (UK) Limited; Cirrus Logic, Inc.; and other companies in the Cirrus Logic group (collectively either "Cirrus" or "Cirrus Logic") are sold subject to Cirrus's terms and conditions of sale supplied at the time of order acknowledgement, including those pertaining to warranty, indemnification, and limitation of liability. Software is provided pursuant to applicable license terms. Cirrus reserves the right to make changes to its products and specifications or to discontinue any product or service without notice. Customers should therefore obtain the latest version of relevant information from Cirrus to verify that the information is current and complete. Testing and other quality control techniques are utilized to the extent Cirrus deems necessary. Specific testing of all parameters of each device is not necessarily performed. In order to minimize risks associated with customer applications, the customer must use adequate design and operating safeguards to minimize inherent or procedural hazards. Cirrus is not liable for applications assistance or customer product design. The customer is solely responsible for its selection and use of Cirrus products.

CERTAIN APPLICATIONS USING SEMICONDUCTOR PRODUCTS MAY INVOLVE POTENTIAL RISKS OF DEATH, PERSONAL INJURY, OR SEVERE PROPERTY OR ENVIRONMENTAL DAMAGE ("CRITICAL APPLICATIONS"). CIRRUS PRODUCTS ARE NOT DESIGNED, AUTHORIZED OR WARRANTED FOR USE IN PRODUCTS SURGICALLY IMPLANTED INTO THE BODY, AUTOMOTIVE SAFETY OR SECURITY DEVICES, NUCLEAR SYSTEMS, LIFE SUPPORT PRODUCTS OR OTHER CRITICAL APPLICATIONS. INCLUSION OF CIRRUS PRODUCTS IN SUCH APPLICATIONS IS UNDERSTOOD TO BE FULLY AT THE CUSTOMER'S RISK AND CIRRUS DISCLAIMS AND MAKES NO WARRANTY, EXPRESS, STATUTORY OR IMPLIED, INCLUDING THE IMPLIED WARRANTIES OF MERCHANTABILITY AND FITNESS FOR PARTICULAR PURPOSE, WITH REGARD TO ANY CIRRUS PRODUCT THAT IS USED IN SUCH A MANNER. IF THE CUSTOMER OR CUSTOMER'S CUSTOMER USES OR PERMITS THE USE OF CIRRUS PRODUCTS IN CRITICAL APPLICATIONS, CUSTOMER AGREES, BY SUCH USE, TO FULLY INDEMNIFY CIRRUS, ITS OFFICERS, DIRECTORS, EMPLOYEES, DISTRIBUTORS AND OTHER AGENTS FROM ANY AND ALL LIABILITY, INCLUDING ATTORNEYS' FEES AND COSTS, THAT MAY RESULT FROM OR ARISE IN CONNECTION WITH THESE USES.

This document is the property of Cirrus and by furnishing this information, Cirrus grants no license, express or implied, under any patents, mask work rights, copyrights, trademarks, trade secrets or other intellectual property rights. Any provision or publication of any third party's products or services does not constitute Cirrus's approval, license, warranty or endorsement thereof. Cirrus gives consent for copies to be made of the information contained herein only for use within your organization with respect to Cirrus integrated circuits or other products of Cirrus, and only if the reproduction is without alteration and is accompanied by all associated copyright, proprietary and other notices and conditions (including this notice). This consent does not extend to other copying such as copying for general distribution, advertising or promotional purposes, or for creating any work for resale. This document and its information is provided "AS IS" without warranty of any kind (express or implied). All statutory warranties and conditions are excluded to the fullest extent possible. No responsibility is assumed by Cirrus for the use of information herein, including use of this information as the basis for manufacture or sale of any items, or for infringement of patents or other rights of third parties. Cirrus Logic, Cirrus, the Cirrus Logic logo design and SoundClear are among the trademarks of Cirrus. Other brand and product names may be trademarks or service marks of their respective owners.

Copyright © 2006–2015 Cirrus Logic, Inc. All rights reserved.

## Looking for pricing, stock, or lifecycle information?

Click below to explore more details on WIN SOURCE:

 [View CS5343-CZZ on WIN SOURCE](#)

 [Cirrus Logic Inc. Information](#)

## Optimize Your Supply Chain with WIN SOURCE Solutions

-  Global Sourcing Solution
-  Obsolete Management
-  Cost Control Management
-  Shortage Management
-  Alternative Solution
-  Excess Inventory Management