



**THE DATASHEET OF  
UCC27423DRG4**



## UCC2742x Dual 4-A High Speed Low-Side MOSFET Drivers With Enable

### 1 Features

- Industry-Standard Pin-Out
- Enable Functions for Each Driver
- High Current Drive Capability of  $\pm 4$  A
- Unique BiPolar and CMOS True Drive Output Stage Provides High Current at MOSFET Miller Thresholds
- TTL/CMOS Compatible Inputs Independent of Supply Voltage
- 20-ns Typical Rise and 15-ns Typical Fall Times with 1.8-nF Load
- Typical Propagation Delay Times of 25 ns with Input Falling and 35 ns with Input Rising
- 4-V to 15-V Supply Voltage
- Dual Outputs Can Be Paralleled for Higher Drive Current
- Available in Thermally Enhanced MSOP PowerPAD™ Package
- Rated From  $-40^{\circ}\text{C}$  to  $125^{\circ}\text{C}$

### 2 Applications

- Switch Mode Power Supplies
- DC/DC Converters
- Motor Controllers
- Line Drivers
- Class D Switching Amplifiers

### 3 Description

The UCC2742x family of high-speed dual MOSFET drivers can deliver large peak currents into capacitive loads. Three standard logic options are offered – dual-inverting, dual-noninverting, and one-inverting and one-noninverting driver. The thermally enhanced 8-pin PowerPAD™ MSOP package (DGN) drastically lowers the thermal resistance to improve long-term reliability. It is also offered in the standard SOIC-8 (D) or PDIP-8 (P) packages.

Using a design that inherently minimizes shoot-through current, these drivers deliver 4A of current where it is needed most at the Miller plateau region during the MOSFET switching transition. A unique BiPolar and MOSFET hybrid output stage in parallel also allows efficient current sourcing and sinking at low supply voltages.

The UCC2742x provides enable (ENB) functions to have better control of the operation of the driver applications. ENBA and ENBB are implemented on pins 1 and 8 which were previously left unused in the industry standard pin-out. They are internally pulled up to  $V_{DD}$  for active high logic and can be left open for standard operation.

#### Device Information<sup>(1)</sup>

PART NUMBER	PACKAGE	BODY SIZE (NOM)
UCC27423	SOIC (8)	4.90 mm x 3.91 mm
UCC27424	MSOP-PowerPAD (8)	3.00 mm x 3.00 mm
UCC27425	PDIP (8)	9.81 mm x 6.35 mm

(1) For all available packages, see the orderable addendum at the end of the data sheet.

#### Simplified Application Diagram

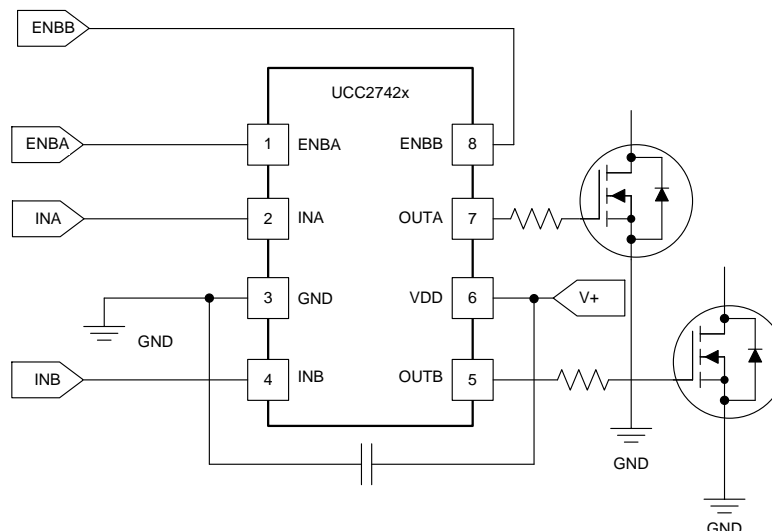

## Table of Contents

<b>1 Features</b> ..... 1 <b>2 Applications</b> ..... 1 <b>3 Description</b> ..... 1 <b>4 Revision History</b> ..... 2 <b>5 Device Comparison Table</b> ..... 3 <b>6 Pin Configuration and Functions</b> ..... 3 <b>7 Specifications</b> ..... 4 7.1 Absolute Maximum Ratings ..... 4 7.2 ESD Ratings..... 4 7.3 Recommended Operating Conditions ..... 4 7.4 Thermal Information ..... 4 7.5 Electrical Characteristics..... 5 7.6 Dissipation Ratings ..... 6 7.7 Typical Characteristics ..... 7 <b>8 Detailed Description</b> ..... 12 8.1 Overview ..... 12 8.2 Functional Block Diagram ..... 12 8.3 Feature Description..... 12	8.4 Device Functional Modes..... 13 <b>9 Application and Implementation</b> ..... 14 9.1 Application Information..... 14 9.2 Typical Application ..... 14 <b>10 Power Supply Recommendations</b> ..... 19 <b>11 Layout</b> ..... 19 11.1 Layout Guidelines ..... 19 11.2 Layout Example ..... 20 11.3 Thermal Considerations ..... 20 <b>12 Device and Documentation Support</b> ..... 21 12.1 Device Support..... 21 12.2 Documentation Support ..... 21 12.3 Related Links ..... 21 12.4 Community Resources..... 21 12.5 Trademarks ..... 22 12.6 Electrostatic Discharge Caution..... 22 12.7 Glossary ..... 22 <b>13 Mechanical, Packaging, and Orderable Information</b> ..... 22
---	--

## 4 Revision History

NOTE: Page numbers for previous revisions may differ from page numbers in the current version.

<b>Changes from Revision D (May 2013) to Revision E</b>	<b>Page</b>
<ul style="list-style-type: none"> <li>• Added <i>ESD Ratings</i> table, <i>Feature Description</i> section, <i>Device Functional Modes</i>, <i>Application and Implementation</i> section, <i>Power Supply Recommendations</i> section, <i>Layout</i> section, <i>Device and Documentation Support</i> section, and <i>Mechanical, Packaging, and Orderable Information</i> section ..... 1</li> </ul>	1
<b>Changes from Revision C (July 2011) to Revision D</b>	<b>Page</b>
<ul style="list-style-type: none"> <li>• Added <i>Pin Functions</i> table note..... 3</li> <li>• Added ABSOLUTE MAXIMUM RATINGS note..... 4</li> <li>• Added additional ENABLE pin description. .... 12</li> </ul>	3 4 12
<b>Changes from Revision B (November 2004) to Revision C</b>	<b>Page</b>
<ul style="list-style-type: none"> <li>• Changed temperature rating..... 1</li> <li>• Changed ORDERING INFORMATION temperature range, three instances. .... 1</li> <li>• Changed Output current (OUTA, OUTB) DC from 0.3 A to 0.2 A..... 4</li> <li>• Changed ELECTRICAL CHARACTERISTICS temperature rating. .... 5</li> <li>• Changed Low-level output level from 40 mV max to 45 mV max. .... 5</li> </ul>	1 1 4 5 5

## 5 Device Comparison Table

OUTPUT CONFIGURATION	TEMPERATURE RANGE $T_A = T_J$	PACKAGED DEVICES		
		SOIC-8 (D) <sup>(1)</sup>	MSOP-8 PowerPAD (DGN) <sup>(2)</sup>	PDIP-8 (P)
Dual inverting	–40°C to 125°C	UCC27423D	UCC27423DGN	UCC27423P
Dual noninverting	–40°C to 125°C	UCC27424D	UCC27424DGN	UCC27424P
One inverting, one noninverting	–40°C to 125°C	UCC27425D	UCC27425DGN	UCC27425P

- (1) D (SOIC-8) and DGN (PowerPAD-MSOP) packages are available taped and reeled. Add R suffix to device type (e.g. UCC27423DR, UCC27424DGNR) to order quantities of 2,500 devices per reel for D or 1,000 devices per reel for DGN package.
- (2) The PowerPAD™ is not directly connected to any leads of the package. However, it is electrically and thermally connected to the substrate which is the ground of the device.

## 6 Pin Configuration and Functions

D Package, DGN Package, P Package  
8-Pin SOIC, 8-Pin MSOP-PowerPAD, 8-Pin PDIP  
Top View

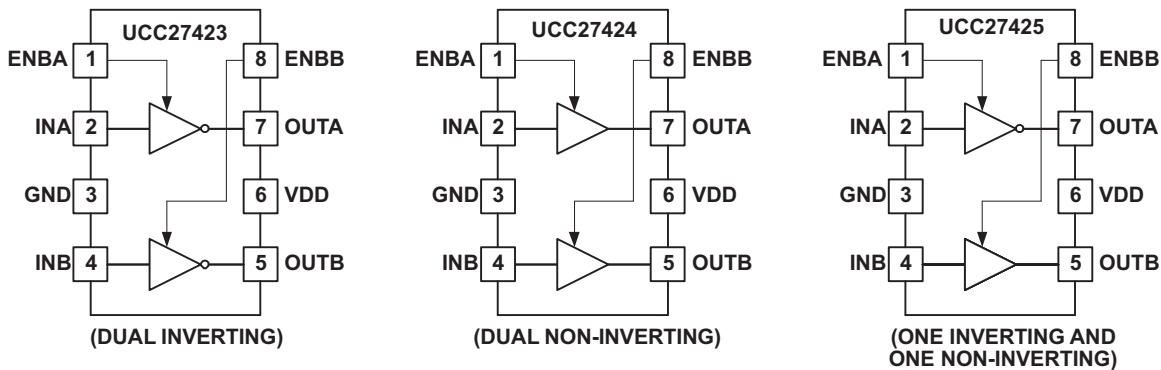

### Pin Functions

PIN		I/O	DESCRIPTION
NAME	NO.		
ENBA	1	I	Enable input for the driver A with logic compatible threshold and hysteresis. The driver output can be enabled and disabled with this pin. It is internally pulled up to $V_{DD}$ with 100 k $\Omega$ resistor for active high operation. The output state when the device is disabled will be low regardless of the input state.
ENBB	8	I	Enable input for the driver B with logic compatible threshold and hysteresis. The driver output can be enabled and disabled with this pin. It is internally pulled up to $V_{DD}$ with 100 k $\Omega$ resistor for active high operation. The output state when the device is disabled will be low regardless of the input state. <sup>(1)</sup>
GND	3	—	Common ground: this ground should be connected very closely to the source of the power MOSFET which the driver is driving.
INA	2	I	Input A: input signal of the A driver which has logic compatible threshold and hysteresis. If not used, this input should be tied to either $V_{DD}$ or GND. It should not be left floating. <sup>(1)</sup>
INB	4	I	Input B: Input signal of the A driver which has logic compatible threshold and hysteresis. If not used, this input should be tied to either $V_{DD}$ or GND. It should not be left floating.
OUTA	7	O	Driver output A. The output stage is capable of providing 4A drive current to the gate of a power MOSFET.
OUTB	5	O	Driver output B. The output stage is capable of providing 4A drive current to the gate of a power MOSFET.
$V_{DD}$	6	I	Supply. Supply voltage and the power input connection for this device.

- (1) Refer to [Detailed Description](#) for more details.

## 7 Specifications

### 7.1 Absolute Maximum Ratings

 over operating free-air temperature range (unless otherwise noted)<sup>(1)(2)</sup>

		MIN	MAX	UNIT
V <sub>DD</sub>	Supply voltage	−0.3	16	V
I <sub>OUT_DC</sub>	Output current (OUTA, OUTB) DC		0.2	A
I <sub>OUT_PULSED</sub>	Pulsed, (0.5 μs)		4.5	A
V <sub>IN</sub>	Input voltage (INA, INB)	−5	6 or V <sub>DD</sub> + 0.3 (whichever is larger)	V
	Enable voltage (ENBA, ENBB)	−0.3	6 or V <sub>DD</sub> + 0.3 (whichever is larger)	V
Power dissipation at T <sub>A</sub> = 25°C	DGN package		3	W
	D package		650	mW
	P package		350	
T <sub>J</sub>	Junction operating temperature	−55	150	°C
	Lead temperature (soldering, 10 s)		300	°C
T <sub>stg</sub>	Storage temperature	−65	150	°C

- (1) Stresses beyond those listed under *Absolute Maximum Ratings* may cause permanent damage to the device. These are stress ratings only, which do not imply functional operation of the device at these or any other conditions beyond those indicated under *Recommended Operating Conditions*. Exposure to absolute-maximum-rated conditions for extended periods may affect device reliability.
- (2) When V<sub>DD</sub> ≤ 6 V, EN rating max value is 6 V; when V<sub>DD</sub> > 6 V, EN rating max value is V<sub>DD</sub> + 0.3 V.

### 7.2 ESD Ratings

		VALUE	UNIT
V <sub>(ESD)</sub>	Electrostatic discharge	Human body model (HBM), per ANSI/ESDA/JEDEC JS-001 <sup>(1)</sup>	±2500
		Charged device model (CDM), per JEDEC specification JESD22-C101 <sup>(2)</sup>	±1500

- (1) JEDEC document JEP155 states that 500-V HBM allows safe manufacturing with a standard ESD control process.
- (2) JEDEC document JEP157 states that 250-V CDM allows safe manufacturing with a standard ESD control process.

### 7.3 Recommended Operating Conditions

over operating free-air temperature range (unless otherwise noted)

		MIN	NOM	MAX	UNIT
V <sub>DD</sub>	Supply voltage	4		15	V
INA and INB	Input voltage	−2		15	V
ENA and ENB	Enable voltage	0		15	V
T <sub>J</sub>	Operating junction temperature	−40		125	°C

### 7.4 Thermal Information

THERMAL METRIC <sup>(1)</sup>		UCC2742x			UNIT
		D (SOIC)	DGN (MSOP)	P (PDIP)	
		8 PINS	8 PINS	8 PINS	
R <sub>θJA</sub>	Junction-to-ambient thermal resistance	107.3	56.6	55.5	°C/W
R <sub>θJC(top)</sub>	Junction-to-case (top) thermal resistance	52.2	52.8	45.3	°C/W
R <sub>θJB</sub>	Junction-to-board thermal resistance	47.3	32.6	32.6	°C/W
ψ <sub>JT</sub>	Junction-to-top characterization parameter	10.2	1.8	23.0	°C/W
ψ <sub>JB</sub>	Junction-to-board characterization parameter	46.8	32.3	32.5	°C/W
R <sub>θJC(bot)</sub>	Junction-to-case (bottom) thermal resistance	–	5.9	–	°C/W

- (1) For more information about traditional and new thermal metrics, see the *Semiconductor and IC Package Thermal Metrics* application report, [SPRA953](#).

## 7.5 Electrical Characteristics

 $V_{DD} = 4.5\text{ V to }15\text{ V}$ ,  $T_A = -40^\circ\text{C to }125^\circ\text{C}$ ,  $T_A = T_J$ , (unless otherwise noted)

PARAMETER		TEST CONDITIONS	MIN	TYP	MAX	UNIT
<b>INPUT (INA, INB)</b>						
$V_{IN\_H}$	Logic 1 input threshold		2			V
$V_{IN\_L}$	Logic 0 input threshold				1	V
	Input current	$0\text{ V} \leq V_{IN} \leq V_{DD}$	-10	0	10	$\mu\text{A}$
<b>OUTPUT (OUTA, OUTB)</b>						
	Output current	$V_{DD} = 14\text{ V}^{(1)}$		4		A
$V_{OH}$	High-level output voltage	$V_{OH} = V_{DD} - V_{OUT}$ , $I_{OUT} = -10\text{ mA}$		330	450	mV
$V_{OL}$	Low-level output level	$I_{OUT} = 10\text{ mA}$		22	45	mV
	Output resistance high	$T_A = 25^\circ\text{C}$ , $I_{OUT} = -10\text{ mA}$ , $V_{DD} = 14\text{ V}^{(2)}$	25	30	35	$\Omega$
		$T_A = \text{full range}$ , $I_{OUT} = -10\text{ mA}$ , $V_{DD} = 14\text{ V}^{(2)}$	18		45	
	Output resistance low	$T_A = 25^\circ\text{C}$ , $I_{OUT} = 10\text{ mA}$ , $V_{DD} = 14\text{ V}^{(2)}$	1.9	2.2	2.5	$\Omega$
		$T_A = \text{full range}$ , $I_{OUT} = 10\text{ mA}$ , $V_{DD} = 14\text{ V}^{(2)}$	1.2		4.0	
	Latch-up protection		500			mA
<b>SWITCHING TIME</b>						
$t_r$	Rise time (OUTA, OUTB)	$C_{LOAD} = 1.8\text{ nF}$		20	40	ns
$t_f$	Fall time (OUTA, OUTB)	$C_{LOAD} = 1.8\text{ nF}$		15	40	
$t_{d1}$	Delay, IN rising (IN to OUT)	$C_{LOAD} = 1.8\text{ nF}$		25	40	
$t_{d2}$	Delay, IN falling (IN to OUT)	$C_{LOAD} = 1.8\text{ nF}$		35	50	
<b>ENABLE (ENBA, ENBB)</b>						
$V_{IN\_H}$	High-level input voltage	LO to HI transition	1.7	2.4	2.9	V
$V_{IN\_L}$	Low-level input voltage	HI to LO transition	1.1	1.8	2.2	V
	Hysteresis		0.15	0.55	0.90	V
$R_{ENB}$	Enable impedance	$V_{DD} = 14\text{ V}$ , $ENB = \text{GND}$	75	100	140	k $\Omega$
$t_{D3}$	Propagation delay time (see <a href="#">Figure 2</a> )	$C_{LOAD} = 1.8\text{ nF}$		30	60	ns
$t_{D4}$	Propagation delay time (see <a href="#">Figure 2</a> )	$C_{LOAD} = 1.8\text{ nF}$		100	150	ns
<b>OVERALL</b>						
$I_{DD}$	UCC27423 Static operating current, $V_{DD} = 15\text{ V}$ , ENBA = ENBB = 15 V	INA = 0 V, INB = 0 V		900	1350	$\mu\text{A}$
		INA = 0 V, INB = HIGH		750	1100	
		INA = HIGH, INB = 0 V		750	1100	
		INA = HIGH, INB = HIGH		600	900	
$I_{DD}$	UCC27424 Static operating current, $V_{DD} = 15\text{ V}$ , ENBA = ENBB = 15 V	INA = 0 V, INB = 0 V		300	450	$\mu\text{A}$
		INA = 0 V, INB = HIGH		750	1100	
		INA = HIGH, INB = 0 V		750	1100	
		INA = HIGH, INB = HIGH		1200	1800	
$I_{DD}$	UCC27425 Static operating current, $V_{DD} = 15\text{ V}$ , ENBA = ENBB = 15 V	INA = 0 V, INB = 0 V		600	900	$\mu\text{A}$
		INA = 0 V, INB = HIGH		1050	1600	
		INA = HIGH, INB = 0 V		450	700	
		INA = HIGH, INB = HIGH		900	1350	
$I_{DD}$	All disabled, $V_{DD} = 15\text{ V}$ , ENBA = ENBB = 0 V	INA = 0 V, INB = 0 V		300	450	$\mu\text{A}$
		INA = 0 V, INB = HIGH		450	700	
		INA = HIGH, INB = 0 V		450	700	
		INA = HIGH, INB = HIGH		600	900	

- (1) The pullup / pulldown circuits of the driver are bipolar and MOSFET transistors in parallel. The pulsed output current rating is the combined current from the bipolar and MOSFET transistors.
- (2) The pullup / pulldown circuits of the driver are bipolar and MOSFET transistors in parallel. The output resistance is the  $R_{ds(on)}$  of the MOSFET transistor when the voltage on the driver output is less than the saturation voltage of the bipolar transistor.

### 7.6 Dissipation Ratings

PACKAGE	SUFFIX	POWER RATING (mW) $T_A = 70^\circ\text{C}^{(1)}$	DERATING FACTOR ABOVE $70^\circ\text{C} \text{ (mW/}^\circ\text{C)}^{(1)}$
SOIC-8	D	344–655 <sup>(2)</sup>	6.25–11.9 <sup>(2)</sup>
PDIP-8	P	500	9
MSOP <sup>(3)</sup>	DGN	1370	17.1

- (1) 125°C operating junction temperature is used for power rating calculations
- (2) The range of values indicates the effect of pc-board. These values are intended to give the system designer an indication of the best and worst case conditions. In general, the system designer should attempt to use larger traces on the pc-board where possible in order to spread the heat away from the device more effectively. For information on the PowerPAD™ package, refer to Technical Brief, *PowerPad Thermally Enhanced Package*, Texas Instruments (SLMA002) and Application Brief, *PowerPad Made Easy*, Texas Instruments (SLMA004).
- (3) The PowerPAD™ is not directly connected to any leads of this package. However, it is electrically and thermally connected to the substrate which is the ground of the device.

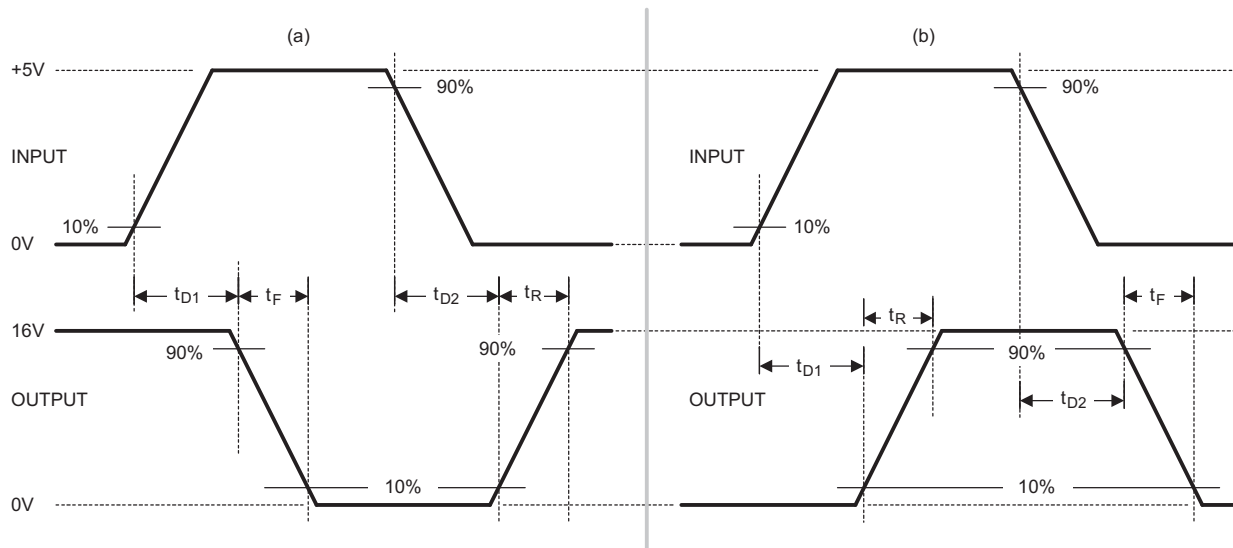
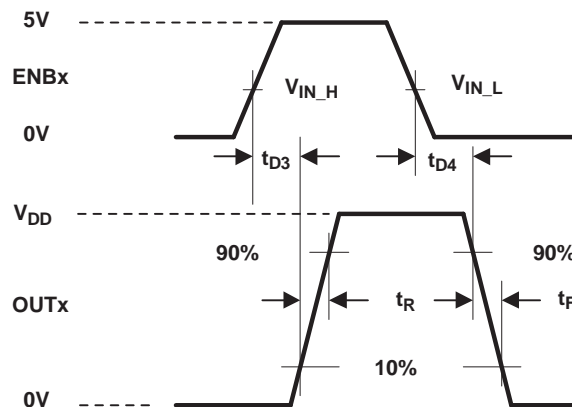

Figure 1. Switching Waveforms for (a) Inverting Driver and (b) Noninverting Driver



NOTE: The 10% and 90% thresholds depict the dynamics of the BiPolar output devices that dominate the power MOSFET transition through the Miller regions of operation.

Figure 2. Switching Waveform for Enable to Output

### 7.7 Typical Characteristics

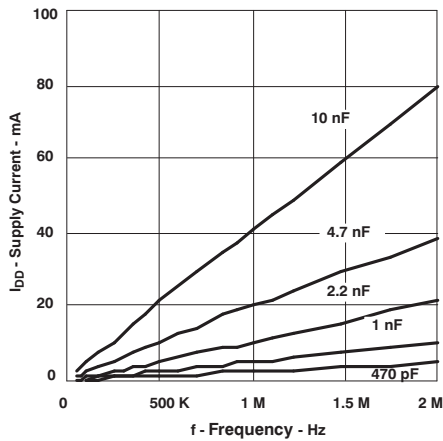

Figure 3. Supply Current vs Frequency ( $V_{DD} = 4.5\text{ V}$ )

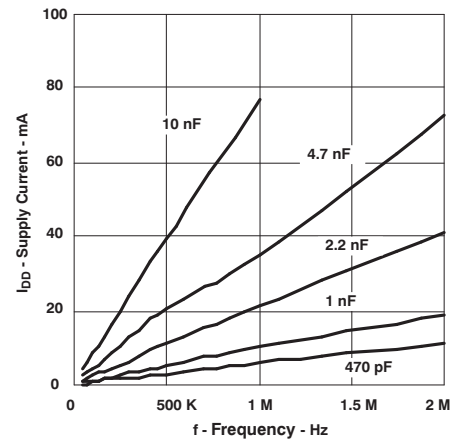

Figure 4. Supply Current vs Frequency ( $V_{DD} = 8.0\text{ V}$ )

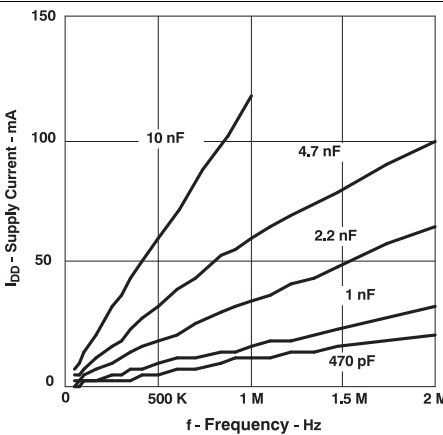

Figure 5. Supply Current vs Frequency ( $V_{DD} = 12\text{ V}$ )

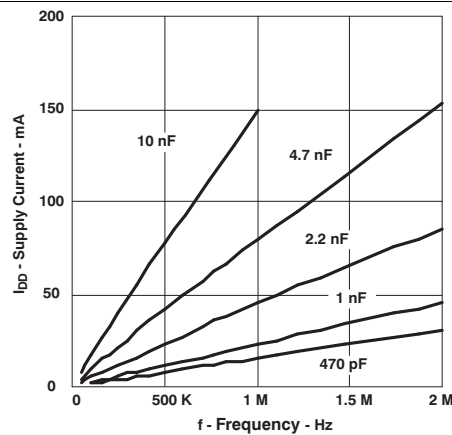

Figure 6. Supply Current vs Frequency ( $V_{DD} = 15\text{ V}$ )

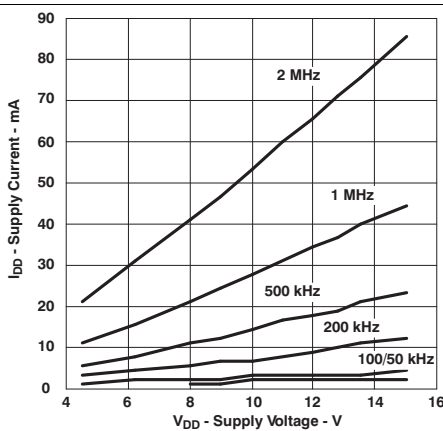

Figure 7. Supply Current vs Supply Voltage ( $C_{LOAD} = 2.2\text{ nF}$ )

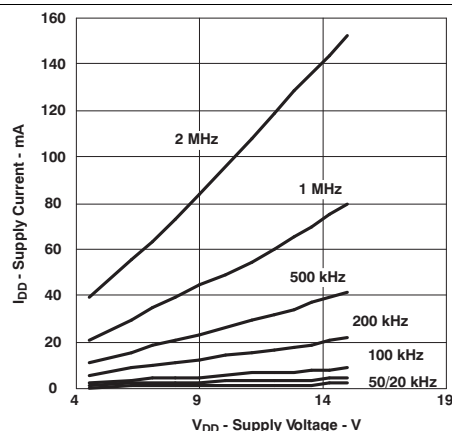

Figure 8. Supply Current vs Supply Voltage ( $C_{LOAD} = 4.7\text{ nF}$ )

Typical Characteristics (continued)

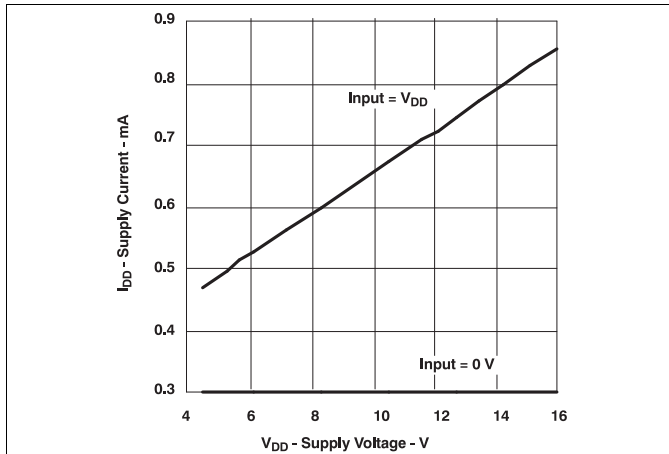

Figure 9. Supply Current vs Supply Voltage (UCC27423)

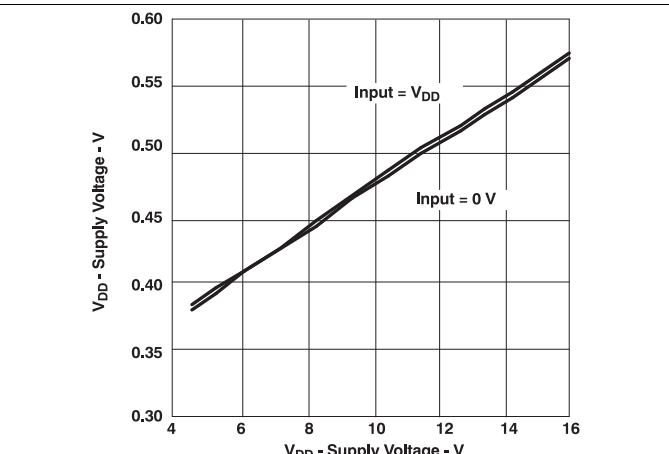

Figure 10. Supply Current vs Supply Voltage (UCC27424)

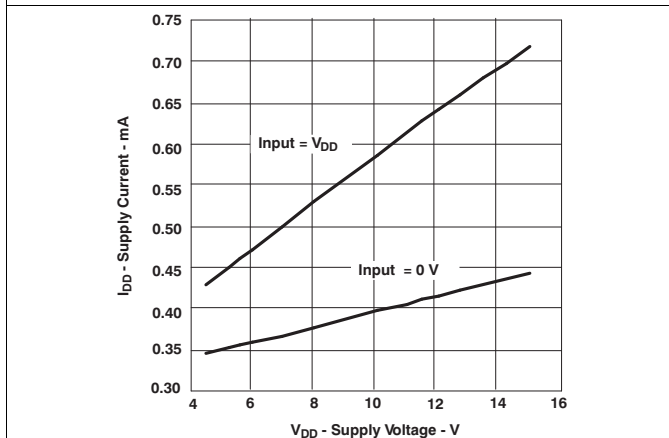

Figure 11. Supply Current vs Supply Voltage (UCC27425)

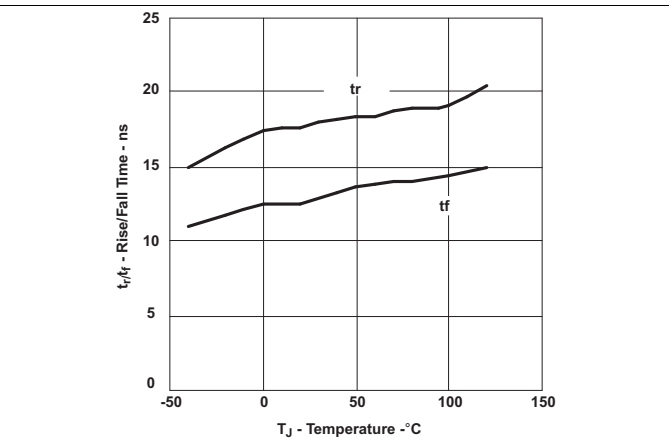

Figure 12. Rise Time and Fall Time vs Temperature (UCC27423)

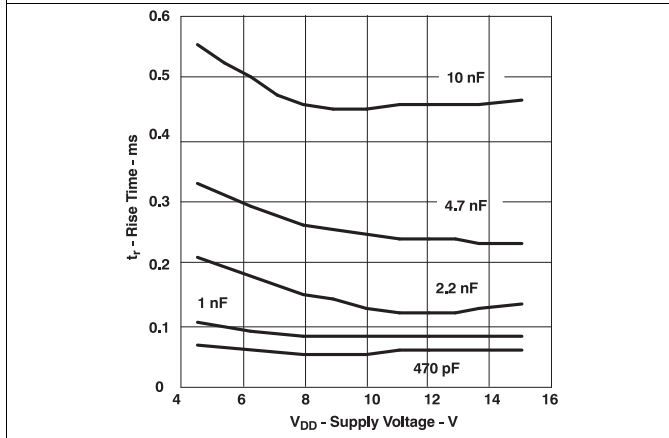

Figure 13. Rise Time vs Supply Voltage

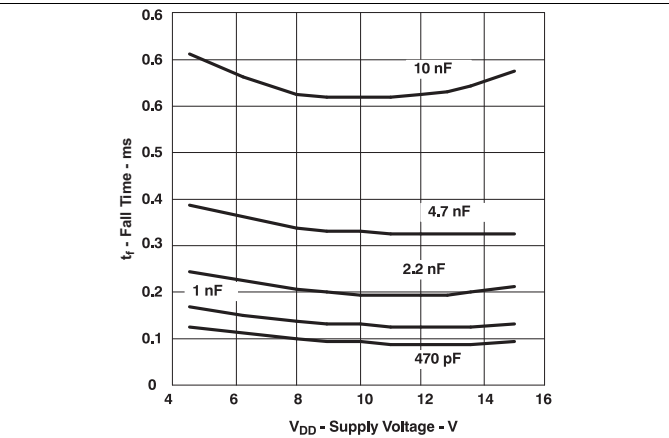

Figure 14. Fall Time vs Supply Voltage

Typical Characteristics (continued)

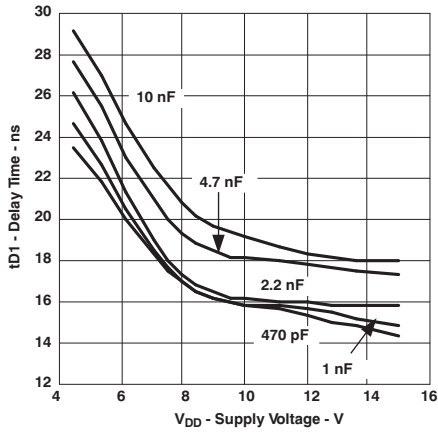

Figure 15. Delay Time ( $t_{D1}$ ) vs Supply Voltage (UCC27423)

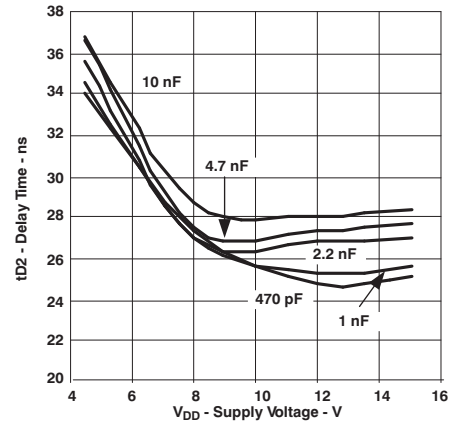

Figure 16. Delay Time ( $t_{D2}$ ) vs Supply Voltage (UCC27423)

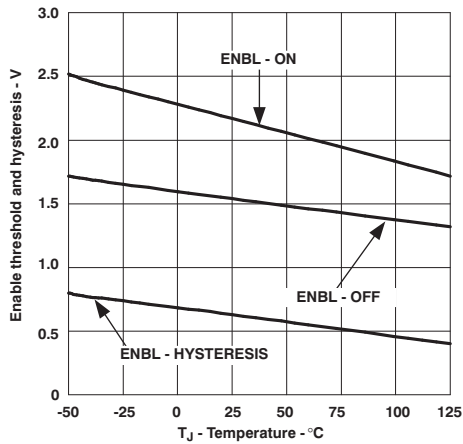

Figure 17. Enable Threshold and Hysteresis vs Temperature

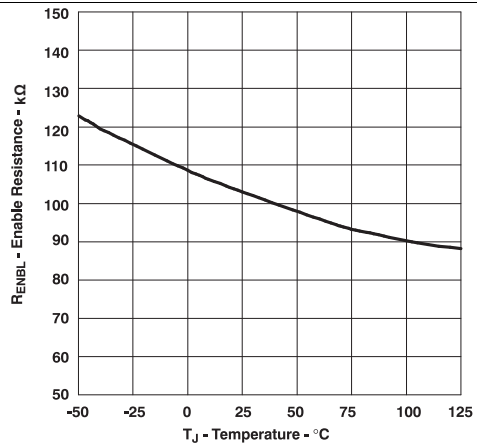

Figure 18. Enable Resistance vs Temperature

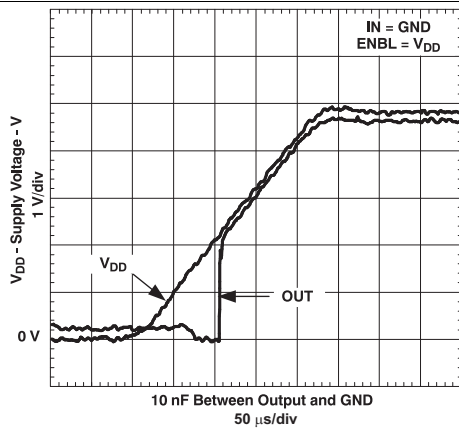

Figure 19. Output Behavior vs Supply Voltage (Inverting)

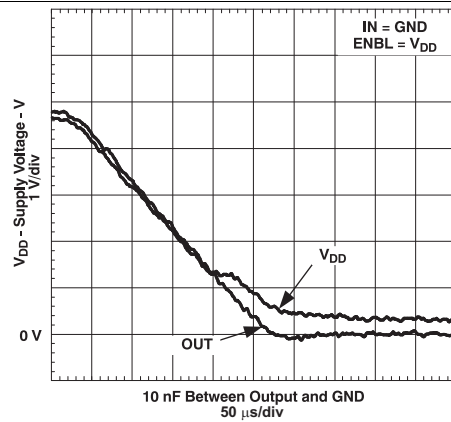

Figure 20. Output Behavior vs Supply Voltage (Inverting)

Typical Characteristics (continued)

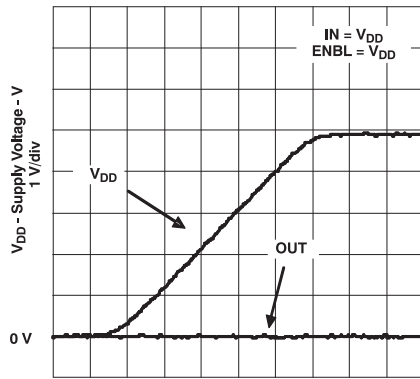

Figure 21. Output Behavior vs  $V_{DD}$  (Inverting)

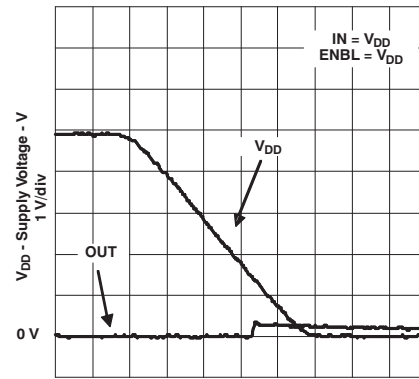

Figure 22. Output Behavior vs  $V_{DD}$  (Inverting)

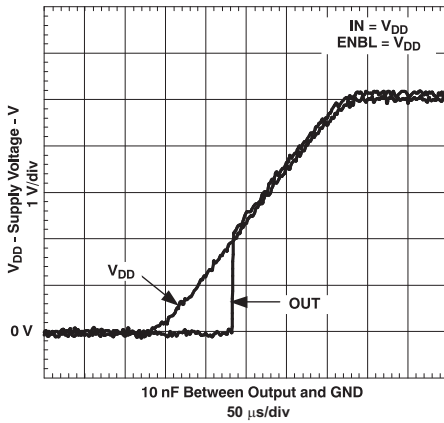

Figure 23. Output Behavior vs  $V_{DD}$  (Noninverting)

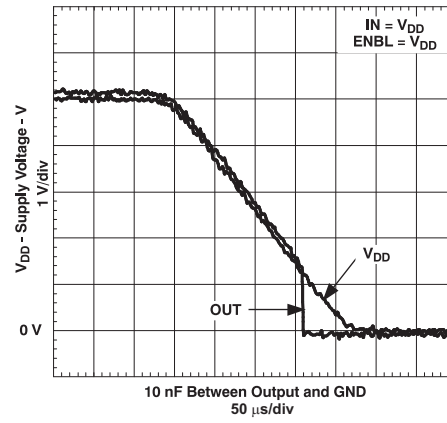

Figure 24. Output Behavior vs  $V_{DD}$  (Noninverting)

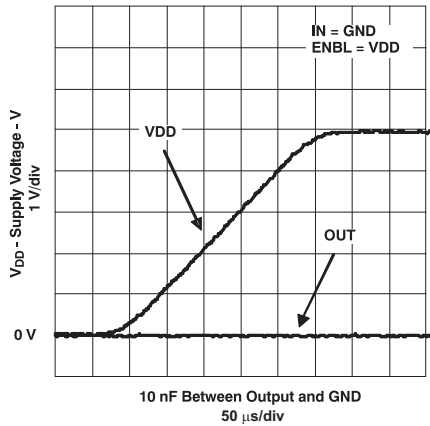

Figure 25. Output Behavior vs  $V_{DD}$  (Noninverting)

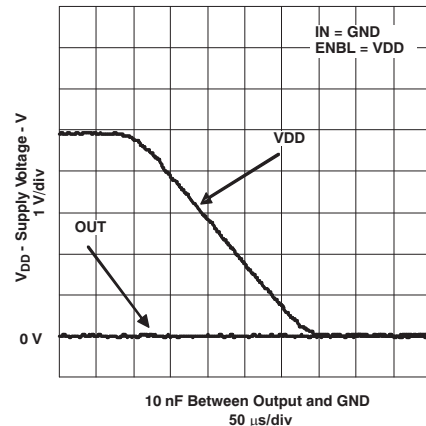

Figure 26. Output Behavior vs  $V_{DD}$  (Noninverting)

Typical Characteristics (continued)

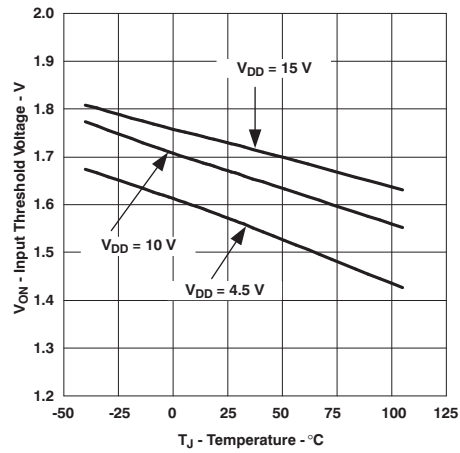

Figure 27. Input Threshold vs Temperature

## 8 Detailed Description

### 8.1 Overview

The UCC2742x family of high-speed dual MOSFET drivers can deliver large peak currents into capacitive loads. Three standard logic options are offered – dual-inverting, dual-noninverting and one-inverting and one-noninverting driver. The thermally enhanced 8-pin PowerPAD™ MSOP package (DGN) drastically lowers the thermal resistance to improve long-term reliability. It is also offered in the standard SOIC-8 (D) or PDIP-8 (P) packages. Using a design that inherently minimizes shoot-through current, these drivers deliver 4A of current where it is needed most at the Miller plateau region during the MOSFET switching transition. A unique Bipolar and MOSFET hybrid output stage in parallel also allows efficient current sourcing and sinking at low supply voltages. [Table 1](#) highlights more details about UCC2742x.

**Table 1. UCC2742x Features and Benefits**

FEATURE	BENEFIT
1-ns (typ) delay matching between channels	Ease of paralleling outputs for higher (2 times) current capability, ease of driving parallel-power switches
Expanded $V_{DD}$ operating range of 4 to 15 V	Flexibility in system design
Outputs enabled when enable pins (ENx) in floating condition	Pin-to-pin compatibility with the UCC27324 device from Texas Instruments and industry standard pinout, in designs where Pin 1 and Pin 8 are in floating condition
CMOS/TTL compatible input and enable threshold with wide hysteresis	Enhanced noise immunity, while retaining compatibility with microcontroller logic-level inputs signals (3.3 V, 5 V) optimized for digital power
Ability to handle $-5 V_{DC}$ (max) at input pins (INA/B)	Increased robustness in noisy environments

### 8.2 Functional Block Diagram

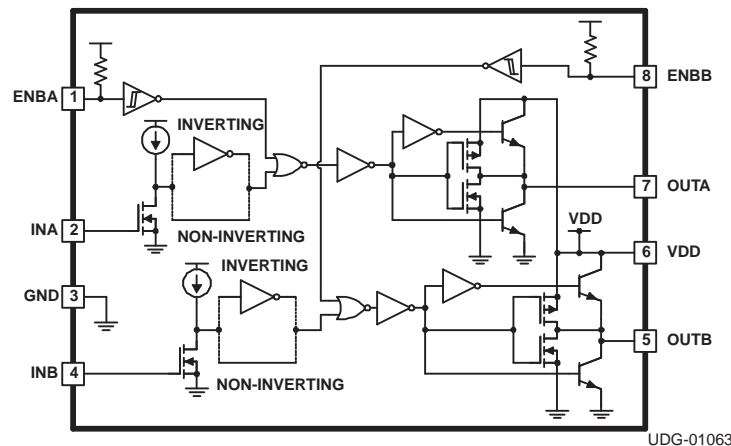

### 8.3 Feature Description

#### 8.3.1 Enable

UCC2742x provides dual Enable inputs for improved control of each driver channel operation. The inputs incorporate logic compatible thresholds with hysteresis. They are internally pulled up to  $V_{DD}$  with 100kΩ resistor for active high operation. When ENBA and ENBB are driven high, the drivers are enabled and when ENBA and ENBB are low, the drivers are disabled. The default state of the Enable pin is to enable the driver and therefore can be left open for standard operation. However, if the enable pin is left open, it is recommended to terminate any PCB traces to be as short as possible to limit noise. If large noise is present due to non-optimal PCB layout, it is recommended to tie the Enable pin to  $V_{CC}$  or to add a filter capacitor (0.1 μF) to the Enable pin. The output states when the drivers are disabled is low regardless of the input state. See the truth table of [Table 2](#) for the operation using enable logic.

## Feature Description (continued)

Enable input are compatible with both logic signals and slow changing analog signals. They can be directly driven or a power-up delay can be programmed with a capacitor between ENBA, ENBB and AGND. ENBA and ENBB control input A and input B respectively.

### 8.3.2 Input Stage

The input thresholds have 3.3 V logic sensitivity over the full range of  $V_{DD}$  voltages; it is equally compatible with 0 to  $V_{DD}$  signals. The inputs of the UCC2742x driver family are designed to withstand 500-mA reverse current without damaging the IC for logic upset. The input stage of each driver should be driven by a signal with a short rise or fall time. This condition is satisfied in typical power supply applications where the input signals are provided by a PWM controller or logic gates with fast transition times (<200 ns). The input stages to the drivers function as a digital gate, and they are not intended for applications where a slow changing input voltage is used to generate a switching output when the logic threshold of the input section is reached. While this may not be harmful to the driver, the output of the driver may switch repeatedly at a high frequency.

Users should not attempt to shape the input signals to the driver in an attempt to slow down (or delay) the signal at the output. If limited rise or fall times to the power device is desired, an external resistance can be added between the output of the driver and the load device which is generally a power MOSFET gate. The external resistor may also help remove power dissipation from the device package, as discussed in the section on Thermal Considerations.

Importantly, input signal of the two channels, INA and INB, which has logic compatible threshold and hysteresis. If not used, INA and INB must be tied to either  $V_{DD}$  or GND; it must not be left floating.

### 8.3.3 Output Stage

Inverting outputs of the UCC27423 and OUTA of the UCC27425 are intended to drive external P-channel MOSFETs. Noninverting outputs of the UCC27424 and OUTB of the UCC27425 are intended to drive external N-Channel MOSFETs. Each output stage is capable of supplying  $\pm 4$  A peak current pulses and swings to both  $V_{DD}$  and GND. The pullup/pulldown circuits of the driver are constructed of bipolar and MOSFET transistors in parallel. The peak output current rating is the combined current from the bipolar and MOSFET transistors. The output resistance is the  $R_{DS(on)}$  of the MOSFET transistor when the voltage on the driver output is less than the saturation voltage of the bipolar transistor. Each output stage also provides very low impedance to overshoot and undershoot due to the body diode of the external MOSFET. This means that in many cases, external-Schottky-clamp diodes are not required. The UCC2742x family delivers 4 A of gate drive where it is most needed during the MOSFET switching transition (at the Miller plateau region) providing improved efficiency gains. A unique Bipolar and MOSFET hybrid output stage in parallel also allows efficient current sourcing at low supply voltages.

## 8.4 Device Functional Modes

With  $V_{DD}$  power supply in the range of 4 V to 16 V, the output stage is dependent on the states of the HI and LI pins. [Table 2](#) shows the UCC2742x truth table.

**Table 2. Input/Output Logic**

		INPUTS (VIN_L, VIN_H)		UCC27423		UCC27424		UCC27425	
ENBA	ENBB	INA	INB	OUTA	OUTB	OUTA	OUTB	OUTA	OUTB
H	H	L	L	H	H	L	L	H	L
H	H	L	H	H	L	L	H	H	H
H	H	H	L	L	H	H	L	L	L
H	H	H	H	L	L	H	H	L	H
L	L	X	X	L	L	L	L	L	L

Importantly, if INA and INB are not used, they must be tied to either  $V_{DD}$  or GND; it must not be left floating.

## 9 Application and Implementation

### NOTE

Information in the following applications sections is not part of the TI component specification, and TI does not warrant its accuracy or completeness. TI's customers are responsible for determining suitability of components for their purposes. Customers should validate and test their design implementation to confirm system functionality.

### 9.1 Application Information

High frequency power supplies often require high-speed, high-current drivers such as the UCC2742x family. A leading application is the need to provide a high power buffer stage between the PWM output of the control IC and the gates of the primary power MOSFET or IGBT switching devices. In other cases, the driver IC is utilized to drive the power device gates through a drive transformer. Synchronous rectification supplies also have the need to simultaneously drive multiple devices which can present an extremely large load to the control circuitry.

Driver ICs are utilized when it is not feasible to have the primary PWM regulator IC directly drive the switching devices for one or more reasons. The PWM IC may not have the brute drive capability required for the intended switching MOSFET, limiting the switching performance in the application. In other cases there may be a desire to minimize the effect of high frequency switching noise by placing the high current driver physically close to the load. Also, newer ICs that target the highest operating frequencies may not incorporate onboard gate drivers at all. Their PWM outputs are only intended to drive the high impedance input to a driver such as the UCC2742x. Finally, the control IC may be under thermal stress due to power dissipation, and an external driver can help by moving the heat from the controller to an external package.

### 9.2 Typical Application

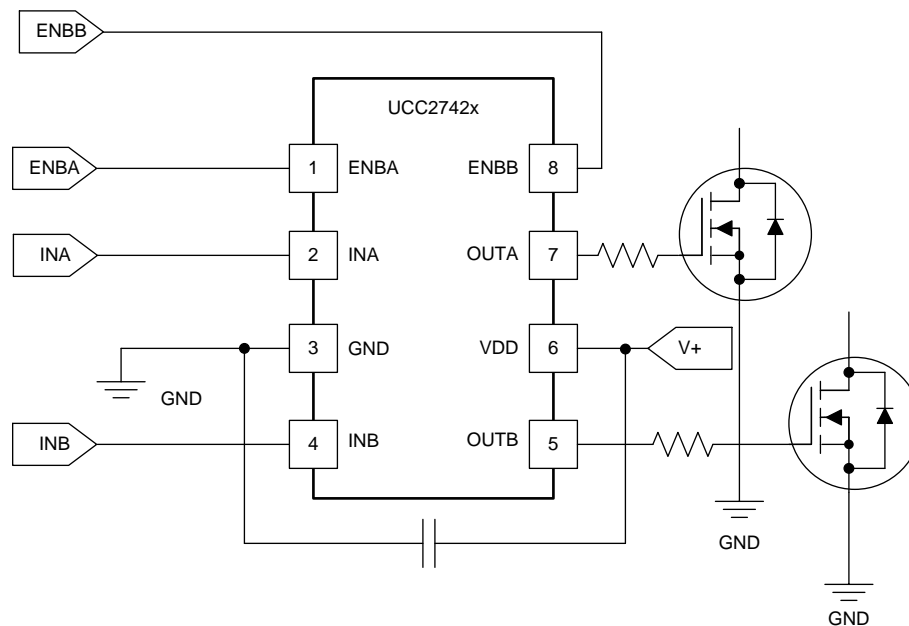

**Figure 28. UCC2742x Driving Two Independent MOSFETs**

#### 9.2.1 Design Requirements

To select proper device from UCC2742x family, it is recommended to first check the appropriate logic for the outputs. UCC27423 has dual inverting outputs; UCC27424 has dual non-inverting outputs; UCC27425 has an inverting channel A and non-inverting channel B. Moreover, some considerations must be evaluated in order to make the most appropriate selection. Among these considerations are  $V_{DD}$ , drive current, and power dissipation.

## Typical Application (continued)

### 9.2.2 Detailed Design Procedure

#### 9.2.2.1 Source and Sink Capabilities During Miller Plateau

Large power MOSFETs present a large load to the control circuitry. Proper drive is required for efficient, reliable operation. The UCC2742x drivers have been optimized to provide maximum drive to a power MOSFET during the Miller plateau region of the switching transition. This interval occurs while the drain voltage is swinging between the voltage levels dictated by the power topology, requiring the charging and discharging of the drain-gate capacitance with current supplied or removed by the driver device.

Two circuits are used to test the current capabilities of the UCC2742x driver. In each case external circuitry is added to clamp the output near 5 V while the IC is sinking or sourcing current. An input pulse of 250 ns is applied at a frequency of 1 kHz in the proper polarity for the respective test. In each test there is a transient period where the current peaked up and then settled down to a steady-state value. The noted current measurements are made at a time of 200 ns after the input pulse is applied, after the initial transient.

The circuit in [Figure 29](#) is used to verify the current sink capability when the output of the driver is clamped around 5V, a typical value of gate-source voltage during the Miller plateau region. The UCC2742x is found to sink 4.5 A at  $V_{DD} = 15\text{ V}$  and 4.28 A at  $V_{DD} = 12\text{ V}$ .

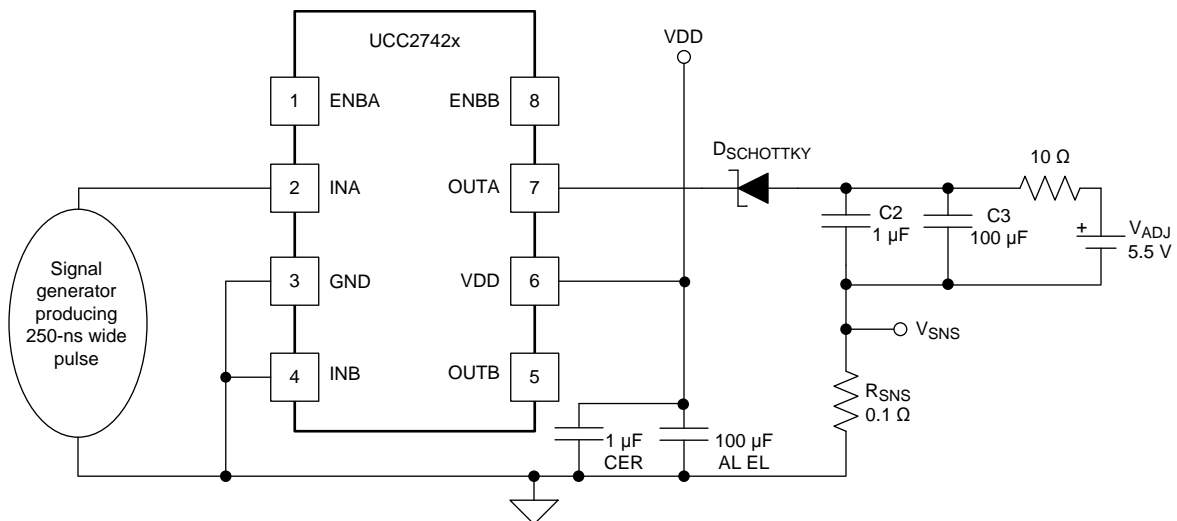
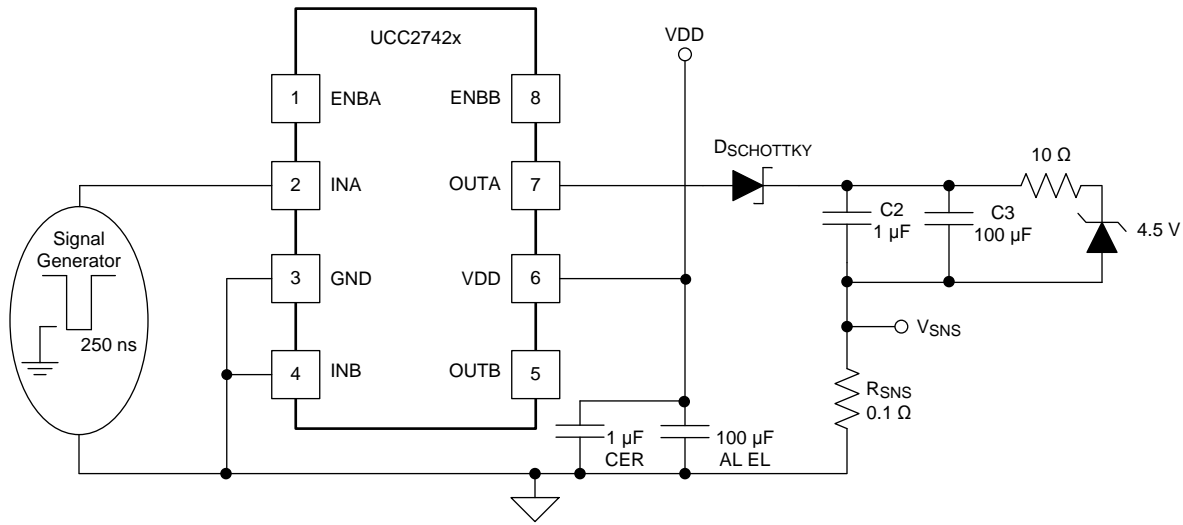
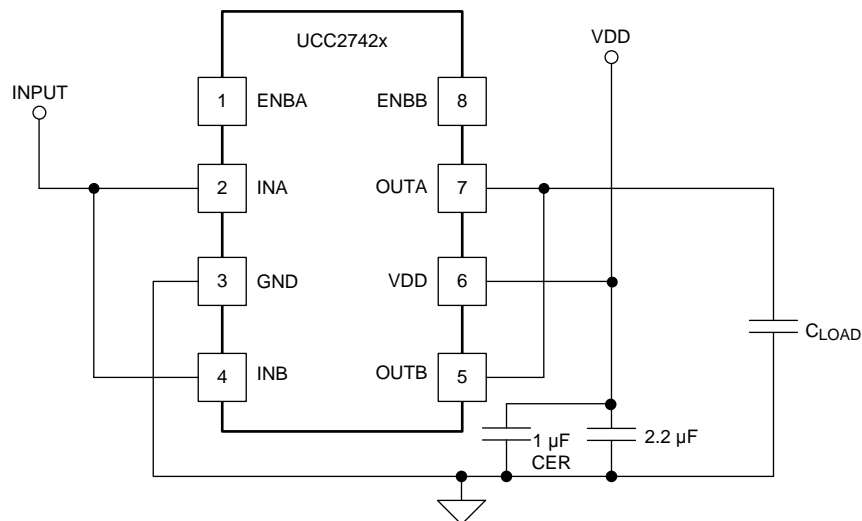

Figure 29. Current Sink Capability Test

The circuit show in [Figure 30](#) is used to test the current source capability with the output clamped around 5 V with a string of Zener diodes. The UCC2742x is found to source 4.8 A at  $V_{DD} = 15\text{ V}$  and 3.7 A at  $V_{DD} = 12\text{ V}$ .

**Typical Application (continued)**

**Figure 30. Current Source Capability Test**
**9.2.2.2 Parallel Outputs**

The A and B drivers may be combined into a single driver by connecting the INA and INB inputs together and the OUTA and OUTB outputs together. Then, a single signal can control the paralleled combination as shown in Figure 31.

**Figure 31. Parallel Operation of UCC27423 and UCC27424**

Important consideration about paralleling two channels for UCC27423/4 include the INA and INB should be shorted in PCB layout as close to the device as possible, as well as for OUTA and OUTB, in which condition PCB layout parasitic mismatching between two channels could be minimized. The INA/B slope signal should be fast enough to avoid mismatched  $V_{IN\_H} / V_{IN\_L}$ ,  $t_{d1} / t_{d2}$  between channel-A and channel-B. It is recommended to have input signal slope faster than 20 V/us.

## Typical Application (continued)

### 9.2.2.3 $V_{DD}$

Although quiescent  $V_{DD}$  current is very low, total supply current will be higher, depending on OUTA and OUTB current and the programmed oscillator frequency. Total  $V_{DD}$  current is the sum of quiescent  $V_{DD}$  current and the average OUT current. Knowing the operating frequency and the MOSFET gate charge ( $Q_g$ ), average OUT current can be calculated from [Equation 1](#).

$$I_{OUT} = Q_g \times f$$

where

- $f$  = switching frequency (1)

For the best high-speed circuit performance, two  $V_{DD}$  bypass capacitors are recommended to prevent noise problems. The use of surface mount components is highly recommended. A 0.1 $\mu$ F ceramic capacitor should be located closest to the  $V_{DD}$  to ground connection. In addition, a larger capacitor (such as 1 $\mu$ F) with relatively low ESR should be connected in parallel, to help deliver the high current peaks to the load. The parallel combination of capacitors should present a low impedance characteristic for the expected current levels in the driver application.

### 9.2.2.4 Drive Current and Power Requirements

The UCC2742x family of drivers are capable of delivering 4 A of current to a MOSFET gate for a period of several hundred nanoseconds. High peak current is required to turn the device ON quickly. Then, to turn the device OFF, the driver is required to sink a similar amount of current to ground. This repeats at the operating frequency of the power device. A MOSFET is used in this discussion because it is the most common type of switching device used in high frequency power conversion equipment.

References 1 and 2 in [Documentation Support](#) discuss the current required to drive a power MOSFET and other capacitive-input switching devices. Reference 2 in [Documentation Support](#) includes information on the previous generation of bipolar IC gate drivers.

When a driver IC is tested with a discrete, capacitive load it is a fairly simple matter to calculate the power that is required from the bias supply. The energy that must be transferred from the bias supply to charge the capacitor is given by [Equation 2](#).

$$E = \frac{1}{2} CV^2$$

where

- $C$  = load capacitor, and  $V$  = bias voltage (feeding the driver) (2)

There is an equal amount of energy transferred to ground when the capacitor is discharged. This leads to a power loss given by [Equation 3](#).

$$P = CV^2 \times f$$

where

- $f$  = switching frequency (3)

This power is dissipated in the resistive elements of the circuit. Thus, with no external resistor between the driver and gate, this power is dissipated inside the driver. Half of the total power is dissipated when the capacitor is charged, and the other half is dissipated when the capacitor is discharged. An actual example using the conditions of the previous gate drive waveform should help clarify this.

With  $V_{DD} = 12$  V,  $C_{LOAD} = 10$  nF, and  $f = 300$  kHz, the power loss can be calculated as [Equation 4](#).

$$P = 10 \text{ nF} \times (12 \text{ V})^2 \times (300 \text{ kHz}) = 0.432 \text{ W} \quad (4)$$

With a 12 V supply, this would equate to a current of [Equation 5](#).

$$I = \frac{P}{V} = \frac{0.432 \text{ W}}{12 \text{ V}} = 36 \text{ mA} \quad (5)$$

### Typical Application (continued)

The actual current measured from the supply was 0.037A, and is very close to the predicted value. But, the  $I_{DD}$  current that is due to the IC internal consumption should be considered. With no load the IC current draw is 0.0027 A. Under this condition the output rise and fall times are faster than with a load. This could lead to an almost insignificant, yet measurable current due to cross-conduction in the output stages of the driver. However, these small current differences are buried in the high frequency switching spikes, and are beyond the measurement capabilities of a basic lab setup. The measured current with 10 nF load is reasonably close to that expected.

The switching load presented by a power MOSFET can be converted to an equivalent capacitance by examining the gate charge required to switch the device. This gate charge includes the effects of the input capacitance plus the added charge needed to swing the drain of the device between the ON and OFF states. Most manufacturers provide specifications that provide the typical and maximum gate charge, in nC, to switch the device under specified conditions. Using the gate charge  $Q_g$ , one can determine the power that must be dissipated when charging a capacitor. This is done by using the equivalence  $Q_g = C_{eff}V$  to provide the power loss in Equation 6.

$$P = C \times V^2 \times f = V \times Q_g \times f \tag{6}$$

This equation allows a power designer to calculate the bias power required to drive a specific MOSFET gate at a specific bias voltage.

### 9.2.3 Application Curves

Figure 32 and Figure 33 shows rising/falling time and turn-on/off propagation delay testing waveform in room temperature for UCC27424, and waveform measurement data (see the bottom part of the waveform). Each channel, INA/INB/OUTA/OUTB, is labeled and displayed on the left hand of the waveforms.

The load capacitance testing condition is 1.8 nF,  $V_{DD} = 12\text{ V}$ , and  $f = 300\text{ kHz}$ .

HI and LI share one same input from function generator, therefore, besides the propagation delay and rising/falling time, the difference of the propagation delay between HO and LO gives the propagation delay matching data.

Note the linear rise and fall edges of the switching waveforms. This is due to the constant output current characteristic of the driver as opposed to the resistive output impedance of traditional MOSFET-based gate drivers.

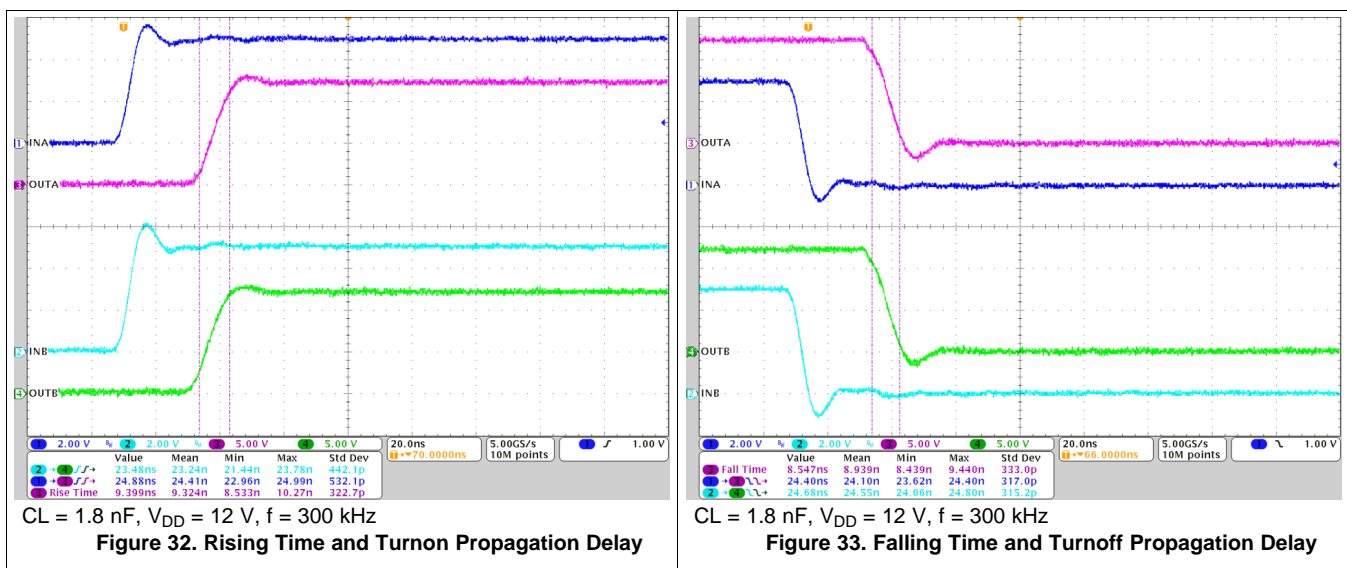

## 10 Power Supply Recommendations

The recommended bias supply voltage range for UCC2742x is from 4 V to 15 V. The upper end of this range is driven by the 16 V absolute maximum voltage rating of the  $V_{DD}$ . It is recommended to keep proper margin to allow for transient voltage spikes.

A local bypass capacitor should be placed between the VDD and GND pins. And this capacitor should be located as close to the device as possible. A low ESR, ceramic surface mount capacitor is recommended. TI recommends using 2 capacitors across VDD and GND: a 100 nF ceramic surface-mount capacitor for high frequency filtering placed very close to VDD and GND pin, and another surface-mount capacitor, 220 nF to 10  $\mu$ F, for IC bias requirements.

## 11 Layout

### 11.1 Layout Guidelines

Optimum performance of gate drivers cannot be achieved without taking due considerations during circuit board layout. The following points are emphasized:

1. Low ESR/ESL capacitors must be connected close to the IC between VDD and GND pins to support high peak currents drawn from VDD during the turn-on of the external MOSFETs.
2. Grounding considerations:
  - The first priority in designing grounding connections is to confine the high peak currents that charge and discharge the MOSFET gates to a minimal physical area. This will decrease the loop inductance and minimize noise issues on the gate terminals of the MOSFETs. The gate driver should be placed as close as possible to the MOSFETs.
  - Star-point grounding is a good way to minimize noise coupling from one current loop to another. The GND of the driver is connected to the other circuit nodes such as source of power MOSFET and ground of PWM controller at one, single point. The connected paths must be as short as possible to reduce inductance.
  - Use a ground plane to provide noise shielding. Fast rise and fall times at OUT may corrupt the input signals during transition. The ground plane must not be a conduction path for any current loop. Instead the ground plane must be connected to the star-point with one single trace to establish the ground potential. In addition to noise shielding, the ground plane can help in power dissipation as well.
3. In noisy environments, tying inputs of an unused channel of the UCC2742x device to VDD or GND using short traces in order to ensure that the output is enabled and to prevent noise from causing malfunction in the output may be necessary.
4. Separate power traces and signal traces, such as output and input signals.

## 11.2 Layout Example

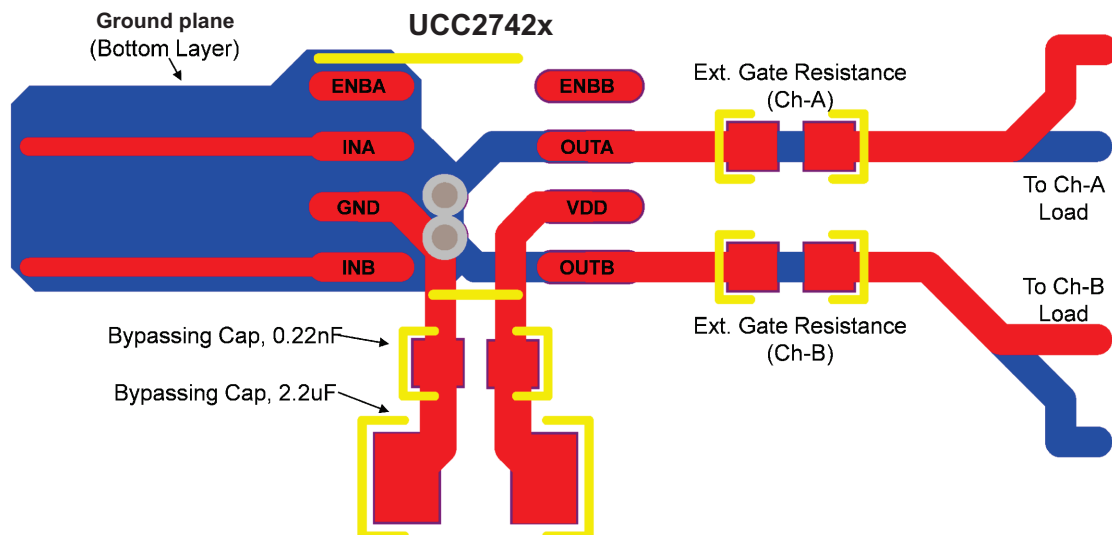

**Figure 34. Recommended PCB Layout for UCC2742x**

## 11.3 Thermal Considerations

The useful range of a driver is greatly affected by the drive power requirements of the load and the thermal characteristics of the IC package. In order for a power driver to be useful over a particular temperature range, the package must allow for the efficient removal of the heat produced while keeping the junction temperature within rated limits. The UCC2742x family of drivers is available in three different packages to cover a range of application requirements.

As shown in the power dissipation rating table, the SOIC-8 (D) and PDIP-8 (P) packages have a power rating of around 0.5 W with  $T_A = 70^\circ\text{C}$ . This limit is imposed in conjunction with the power derating factor also given in [Dissipation Ratings](#). Note that the power dissipation in our earlier example is 0.432W with a 10nF load, 12 V<sub>DD</sub>, switched at 300kHz. Thus, only one load of this size could be driven using the D or P package, even if the two onboard drivers are paralleled. The difficulties with heat removal limit the drive available in the older packages.

The MSOP PowerPAD-8 (DGN) package significantly relieves this concern by offering an effective means of removing the heat from the semiconductor junction. As illustrated in Reference 3 of [Documentation Support](#), the PowerPAD packages offer a leadframe die pad that is exposed at the base of the package. This pad is soldered to the copper on the PC board directly underneath the IC package, reducing the  $R_{\theta\text{JC}(\text{bot})}$  down to 5.9°C/W. Data is presented in Reference 3 of [Documentation Support](#) to show that the power dissipation can be quadrupled in the PowerPAD configuration when compared to the standard packages. The PC board must be designed with thermal lands and thermal vias to complete the heat removal subsystem, as summarized in Reference 4 of [Documentation Support](#). This allows a significant improvement in heatsinking over that available in the D or P packages, and is shown to more than double the power capability of the D and P packages. Note that the PowerPAD™ is not directly connected to any leads of the package. However, it is electrically and thermally connected to the substrate which is the ground of the device.

## 12 Device and Documentation Support

### 12.1 Device Support

#### 12.1.1 Related Products

PRODUCT	DESCRIPTION	PACKAGES
<a href="#">UCC37323</a> <a href="#">UCC37324</a> <a href="#">UCC37325</a>	Dual 4-A Low-Side Drivers	MSOP-8 PowerPAD, SOIC-8, PDIP-8
<a href="#">UCC37321</a> <a href="#">UCC37322</a>	Single 9-A Low-Side Driver with Enable	MSOP-8 PowerPAD, SOIC-8, PDIP-8
<a href="#">TPS2811</a> <a href="#">TPS2812</a> <a href="#">TPS2813</a>	Dual 2-A Low-Side Drivers with Internal Regulator	TSSOP-8, SOIC-8, PDIP-8
<a href="#">TPS2814</a> <a href="#">TPS2815</a>	Dual 2-A Low-Side Drivers with Two Inputs per Channel	TSSOP-8, SOIC-8, PDIP-8
<a href="#">TPS2816</a> <a href="#">TPS2817</a> <a href="#">TPS2818</a> <a href="#">TPS2819</a>	Single 2-A Low-Side Driver with Internal Regulator	5-Pin SOT-23
<a href="#">TPS2828</a> <a href="#">TPS2829</a>	Single 2-A Low-Side Driver	5-Pin SOT-23

### 12.2 Documentation Support

#### 12.2.1 Related Documentation

- Power Supply Seminar SEM-1400 Topic 2: *Design And Application Guide For High Speed MOSFET Gate Drive Circuits*, by Laszlo Balogh, Texas Instruments ([SLUP133](#)).
- Application Note, *Practical Considerations in High Performance MOSFET, IGBT and MCT Gate Drive Circuits*, by Bill Andreyca, Texas Instruments ([SLUA105](#))
- Technical Brief, *PowerPad Thermally Enhanced Package*, Texas Instruments ([SLMA002](#))
- Application Brief, *PowerPAD Made Easy*, Texas Instruments ([SLMA004](#))

### 12.3 Related Links

The table below lists quick access links. Categories include technical documents, support and community resources, tools and software, and quick access to sample or buy.

**Table 3. Related Links**

PARTS	PRODUCT FOLDER	SAMPLE & BUY	TECHNICAL DOCUMENTS	TOOLS & SOFTWARE	SUPPORT & COMMUNITY
UCC27423	<a href="#">Click here</a>	<a href="#">Click here</a>	<a href="#">Click here</a>	<a href="#">Click here</a>	<a href="#">Click here</a>
UCC27424	<a href="#">Click here</a>	<a href="#">Click here</a>	<a href="#">Click here</a>	<a href="#">Click here</a>	<a href="#">Click here</a>
UCC27425	<a href="#">Click here</a>	<a href="#">Click here</a>	<a href="#">Click here</a>	<a href="#">Click here</a>	<a href="#">Click here</a>

### 12.4 Community Resources

The following links connect to TI community resources. Linked contents are provided "AS IS" by the respective contributors. They do not constitute TI specifications and do not necessarily reflect TI's views; see TI's [Terms of Use](#).

**TI E2E™ Online Community** *TI's Engineer-to-Engineer (E2E) Community*. Created to foster collaboration among engineers. At [e2e.ti.com](http://e2e.ti.com), you can ask questions, share knowledge, explore ideas and help solve problems with fellow engineers.

**Design Support** *TI's Design Support* Quickly find helpful E2E forums along with design support tools and contact information for technical support.

## 12.5 Trademarks

PowerPAD, E2E are trademarks of Texas Instruments.  
All other trademarks are the property of their respective owners.

## 12.6 Electrostatic Discharge Caution



These devices have limited built-in ESD protection. The leads should be shorted together or the device placed in conductive foam during storage or handling to prevent electrostatic damage to the MOS gates.

## 12.7 Glossary

[SLYZ022](#) — *TI Glossary*.

This glossary lists and explains terms, acronyms, and definitions.

## 13 Mechanical, Packaging, and Orderable Information

The following pages include mechanical, packaging, and orderable information. This information is the most current data available for the designated devices. This data is subject to change without notice and revision of this document. For browser-based versions of this data sheet, refer to the left-hand navigation.

**PACKAGING INFORMATION**

Orderable Device	Status (1)	Package Type	Package Drawing	Pins	Package Qty	Eco Plan (2)	Lead/Ball Finish (6)	MSL Peak Temp (3)	Op Temp (°C)	Device Marking (4/5)	Samples
UCC27423D	ACTIVE	SOIC	D	8	75	Green (RoHS & no Sb/Br)	CU NIPDAU	Level-1-260C-UNLIM	-40 to 105	27423	<a href="#">Samples</a>
UCC27423DGN	ACTIVE	MSOP- PowerPAD	DGN	8	80	Green (RoHS & no Sb/Br)	CU NIPDAUAG	Level-1-260C-UNLIM	-40 to 105	27423	<a href="#">Samples</a>
UCC27423DGNR	ACTIVE	MSOP- PowerPAD	DGN	8	2500	Green (RoHS & no Sb/Br)	CU NIPDAUAG	Level-1-260C-UNLIM	-40 to 105	27423	<a href="#">Samples</a>
UCC27423DR	ACTIVE	SOIC	D	8	2500	Green (RoHS & no Sb/Br)	CU NIPDAU	Level-1-260C-UNLIM	-40 to 105	27423	<a href="#">Samples</a>
UCC27423P	ACTIVE	PDIP	P	8	50	Pb-Free (RoHS)	CU NIPDAU	N / A for Pkg Type	-40 to 105	27423	<a href="#">Samples</a>
UCC27424D	ACTIVE	SOIC	D	8	75	Green (RoHS & no Sb/Br)	CU NIPDAU	Level-1-260C-UNLIM	-40 to 105	27424	<a href="#">Samples</a>
UCC27424DGN	ACTIVE	MSOP- PowerPAD	DGN	8	80	Green (RoHS & no Sb/Br)	CU NIPDAU   CU NIPDAUAG	Level-1-260C-UNLIM	-40 to 105	27424	<a href="#">Samples</a>
UCC27424DGNG4	ACTIVE	MSOP- PowerPAD	DGN	8	80	Green (RoHS & no Sb/Br)	CU NIPDAUAG	Level-1-260C-UNLIM	-40 to 105	27424	<a href="#">Samples</a>
UCC27424DGNR	ACTIVE	MSOP- PowerPAD	DGN	8	2500	Green (RoHS & no Sb/Br)	CU NIPDAU   CU NIPDAUAG	Level-1-260C-UNLIM	-40 to 105	27424	<a href="#">Samples</a>
UCC27424DGNRG4	ACTIVE	MSOP- PowerPAD	DGN	8	2500	Green (RoHS & no Sb/Br)	CU NIPDAUAG	Level-1-260C-UNLIM	-40 to 105	27424	<a href="#">Samples</a>
UCC27424DR	ACTIVE	SOIC	D	8	2500	Green (RoHS & no Sb/Br)	CU NIPDAU	Level-1-260C-UNLIM	-40 to 105	27424	<a href="#">Samples</a>
UCC27424DRG4	ACTIVE	SOIC	D	8	2500	Green (RoHS & no Sb/Br)	CU NIPDAU	Level-1-260C-UNLIM	-40 to 105	27424	<a href="#">Samples</a>
UCC27424P	ACTIVE	PDIP	P	8	50	Pb-Free (RoHS)	CU NIPDAU	N / A for Pkg Type	-40 to 105	27424	<a href="#">Samples</a>
UCC27425D	ACTIVE	SOIC	D	8	75	Green (RoHS & no Sb/Br)	CU NIPDAU	Level-1-260C-UNLIM	-40 to 105	27425	<a href="#">Samples</a>
UCC27425DG4	ACTIVE	SOIC	D	8	75	Green (RoHS & no Sb/Br)	CU NIPDAU	Level-1-260C-UNLIM	-40 to 105	27425	<a href="#">Samples</a>
UCC27425DGN	ACTIVE	MSOP- PowerPAD	DGN	8	80	Green (RoHS & no Sb/Br)	CU NIPDAUAG	Level-1-260C-UNLIM	-40 to 105	27425	<a href="#">Samples</a>
UCC27425DGNR	ACTIVE	MSOP- PowerPAD	DGN	8	2500	Green (RoHS & no Sb/Br)	CU NIPDAUAG	Level-1-260C-UNLIM	-40 to 105	27425	<a href="#">Samples</a>

Orderable Device	Status (1)	Package Type	Package Drawing	Pins	Package Qty	Eco Plan (2)	Lead/Ball Finish (6)	MSL Peak Temp (3)	Op Temp (°C)	Device Marking (4/5)	Samples
UCC27425DR	ACTIVE	SOIC	D	8	2500	Green (RoHS & no Sb/Br)	CU NIPDAU	Level-1-260C-UNLIM	-40 to 105	27425	<a href="#">Samples</a>
UCC27425DRG4	ACTIVE	SOIC	D	8	2500	Green (RoHS & no Sb/Br)	CU NIPDAU	Level-1-260C-UNLIM	-40 to 105	27425	<a href="#">Samples</a>
UCC27425P	ACTIVE	PDIP	P	8	50	Pb-Free (RoHS)	CU NIPDAU	N / A for Pkg Type	-40 to 105	27425	<a href="#">Samples</a>
UCC27425PE4	ACTIVE	PDIP	P	8	50	Pb-Free (RoHS)	CU NIPDAU	N / A for Pkg Type	-40 to 105	27425	<a href="#">Samples</a>

(1) The marketing status values are defined as follows:

**ACTIVE:** Product device recommended for new designs.

**LIFEBUY:** TI has announced that the device will be discontinued, and a lifetime-buy period is in effect.

**NRND:** Not recommended for new designs. Device is in production to support existing customers, but TI does not recommend using this part in a new design.

**PREVIEW:** Device has been announced but is not in production. Samples may or may not be available.

**OBSOLETE:** TI has discontinued the production of the device.

(2) **RoHS:** TI defines "RoHS" to mean semiconductor products that are compliant with the current EU RoHS requirements for all 10 RoHS substances, including the requirement that RoHS substance do not exceed 0.1% by weight in homogeneous materials. Where designed to be soldered at high temperatures, "RoHS" products are suitable for use in specified lead-free processes. TI may reference these types of products as "Pb-Free".

**RoHS Exempt:** TI defines "RoHS Exempt" to mean products that contain lead but are compliant with EU RoHS pursuant to a specific EU RoHS exemption.

**Green:** TI defines "Green" to mean the content of Chlorine (Cl) and Bromine (Br) based flame retardants meet JS709B low halogen requirements of <=1000ppm threshold. Antimony trioxide based flame retardants must also meet the <=1000ppm threshold requirement.

(3) MSL, Peak Temp. - The Moisture Sensitivity Level rating according to the JEDEC industry standard classifications, and peak solder temperature.

(4) There may be additional marking, which relates to the logo, the lot trace code information, or the environmental category on the device.

(5) Multiple Device Markings will be inside parentheses. Only one Device Marking contained in parentheses and separated by a "-" will appear on a device. If a line is indented then it is a continuation of the previous line and the two combined represent the entire Device Marking for that device.

(6) Lead/Ball Finish - Orderable Devices may have multiple material finish options. Finish options are separated by a vertical ruled line. Lead/Ball Finish values may wrap to two lines if the finish value exceeds the maximum column width.

**Important Information and Disclaimer:**The information provided on this page represents TI's knowledge and belief as of the date that it is provided. TI bases its knowledge and belief on information provided by third parties, and makes no representation or warranty as to the accuracy of such information. Efforts are underway to better integrate information from third parties. TI has taken and continues to take reasonable steps to provide representative and accurate information but may not have conducted destructive testing or chemical analysis on incoming materials and chemicals. TI and TI suppliers consider certain information to be proprietary, and thus CAS numbers and other limited information may not be available for release.

In no event shall TI's liability arising out of such information exceed the total purchase price of the TI part(s) at issue in this document sold by TI to Customer on an annual basis.

**OTHER QUALIFIED VERSIONS OF UCC27423, UCC27424, UCC27425 :**

- Automotive: [UCC27423-Q1](#), [UCC27424-Q1](#), [UCC27425-Q1](#)
- Enhanced Product: [UCC27423-EP](#), [UCC27424-EP](#)

NOTE: Qualified Version Definitions:

- Automotive - Q100 devices qualified for high-reliability automotive applications targeting zero defects
- Enhanced Product - Supports Defense, Aerospace and Medical Applications

**TAPE AND REEL INFORMATION**

**QUADRANT ASSIGNMENTS FOR PIN 1 ORIENTATION IN TAPE**

\*All dimensions are nominal

Device	Package Type	Package Drawing	Pins	SPQ	Reel Diameter (mm)	Reel Width W1 (mm)	A0 (mm)	B0 (mm)	K0 (mm)	P1 (mm)	W (mm)	Pin1 Quadrant
UCC27423DGNR	MSOP-Power PAD	DGN	8	2500	330.0	12.4	5.3	3.4	1.4	8.0	12.0	Q1
UCC27423DR	SOIC	D	8	2500	330.0	12.4	6.4	5.2	2.1	8.0	12.0	Q1
UCC27424DGNR	MSOP-Power PAD	DGN	8	2500	330.0	12.4	5.3	3.4	1.4	8.0	12.0	Q1
UCC27424DGNR	MSOP-Power PAD	DGN	8	2500	330.0	12.4	5.3	3.4	1.4	8.0	12.0	Q1
UCC27424DR	SOIC	D	8	2500	330.0	12.4	6.4	5.2	2.1	8.0	12.0	Q1
UCC27424DR	SOIC	D	8	2500	330.0	12.4	6.4	5.2	2.1	8.0	12.0	Q1
UCC27425DGNR	MSOP-Power PAD	DGN	8	2500	330.0	12.4	5.3	3.4	1.4	8.0	12.0	Q1
UCC27425DR	SOIC	D	8	2500	330.0	12.4	6.4	5.2	2.1	8.0	12.0	Q1

**TAPE AND REEL BOX DIMENSIONS**

\*All dimensions are nominal

Device	Package Type	Package Drawing	Pins	SPQ	Length (mm)	Width (mm)	Height (mm)
UCC27423DGNR	MSOP-PowerPAD	DGN	8	2500	364.0	364.0	27.0
UCC27423DR	SOIC	D	8	2500	340.5	338.1	20.6
UCC27424DGNR	MSOP-PowerPAD	DGN	8	2500	346.0	346.0	29.0
UCC27424DGNR	MSOP-PowerPAD	DGN	8	2500	364.0	364.0	27.0
UCC27424DR	SOIC	D	8	2500	340.5	338.1	20.6
UCC27424DR	SOIC	D	8	2500	367.0	367.0	35.0
UCC27425DGNR	MSOP-PowerPAD	DGN	8	2500	364.0	364.0	27.0
UCC27425DR	SOIC	D	8	2500	340.5	338.1	20.6



D0008A

# PACKAGE OUTLINE

SOIC - 1.75 mm max height

SMALL OUTLINE INTEGRATED CIRCUIT



4214825/C 02/2019

### NOTES:

- Linear dimensions are in inches [millimeters]. Dimensions in parenthesis are for reference only. Controlling dimensions are in inches. Dimensioning and tolerancing per ASME Y14.5M.
- This drawing is subject to change without notice.
- This dimension does not include mold flash, protrusions, or gate burrs. Mold flash, protrusions, or gate burrs shall not exceed  $.006$  [0.15] per side.
- This dimension does not include interlead flash.
- Reference JEDEC registration MS-012, variation AA.

# EXAMPLE BOARD LAYOUT

D0008A

SOIC - 1.75 mm max height

SMALL OUTLINE INTEGRATED CIRCUIT



LAND PATTERN EXAMPLE  
 EXPOSED METAL SHOWN  
 SCALE:8X



SOLDER MASK DETAILS

4214825/C 02/2019

NOTES: (continued)

- 6. Publication IPC-7351 may have alternate designs.
- 7. Solder mask tolerances between and around signal pads can vary based on board fabrication site.

# EXAMPLE STENCIL DESIGN

D0008A

SOIC - 1.75 mm max height

SMALL OUTLINE INTEGRATED CIRCUIT



SOLDER PASTE EXAMPLE  
BASED ON .005 INCH [0.125 MM] THICK STENCIL  
SCALE:8X

4214825/C 02/2019

NOTES: (continued)

8. Laser cutting apertures with trapezoidal walls and rounded corners may offer better paste release. IPC-7525 may have alternate design recommendations.
9. Board assembly site may have different recommendations for stencil design.

P (R-PDIP-T8)

PLASTIC DUAL-IN-LINE PACKAGE



- NOTES:
- A. All linear dimensions are in inches (millimeters).
  - B. This drawing is subject to change without notice.
  - C. Falls within JEDEC MS-001 variation BA.

DGN (S-PDSO-G8)

PowerPAD™ PLASTIC SMALL OUTLINE



- NOTES:
- All linear dimensions are in millimeters.
  - This drawing is subject to change without notice.
  - Body dimensions do not include mold flash or protrusion.
  - This package is designed to be soldered to a thermal pad on the board. Refer to Technical Brief, PowerPad Thermally Enhanced Package, Texas Instruments Literature No. SLMA002 for information regarding recommended board layout. This document is available at [www.ti.com](http://www.ti.com) <<http://www.ti.com>>.
  - See the additional figure in the Product Data Sheet for details regarding the exposed thermal pad features and dimensions.
  - Falls within JEDEC MO-187 variation AA-T

PowerPAD is a trademark of Texas Instruments.

DGN (S-PDSO-G8)

PowerPAD™ PLASTIC SMALL OUTLINE

## THERMAL INFORMATION

This PowerPAD™ package incorporates an exposed thermal pad that is designed to be attached to a printed circuit board (PCB). The thermal pad must be soldered directly to the PCB. After soldering, the PCB can be used as a heatsink. In addition, through the use of thermal vias, the thermal pad can be attached directly to the appropriate copper plane shown in the electrical schematic for the device, or alternatively, can be attached to a special heatsink structure designed into the PCB. This design optimizes the heat transfer from the integrated circuit (IC).

For additional information on the PowerPAD package and how to take advantage of its heat dissipating abilities, refer to Technical Brief, PowerPAD Thermally Enhanced Package, Texas Instruments Literature No. SLMA002 and Application Brief, PowerPAD Made Easy, Texas Instruments Literature No. SLMA004. Both documents are available at [www.ti.com](http://www.ti.com).

The exposed thermal pad dimensions for this package are shown in the following illustration.

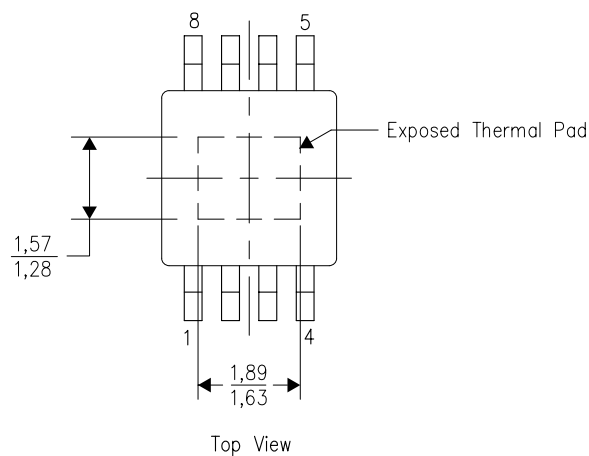

Exposed Thermal Pad Dimensions

4206323-2/1 12/11

NOTE: All linear dimensions are in millimeters

PowerPAD is a trademark of Texas Instruments



- NOTES:
- A. All linear dimensions are in millimeters.
  - B. This drawing is subject to change without notice.
  - C. Customers should place a note on the circuit board fabrication drawing not to alter the center solder mask defined pad.
  - D. This package is designed to be soldered to a thermal pad on the board. Refer to Technical Brief, PowerPad Thermally Enhanced Package, Texas Instruments Literature No. SLMA002, SLMA004, and also the Product Data Sheets for specific thermal information, via requirements, and recommended board layout. These documents are available at [www.ti.com](http://www.ti.com) <<http://www.ti.com>>.
  - E. Laser cutting apertures with trapezoidal walls and also rounding corners will offer better paste release. Customers should contact their board assembly site for stencil design recommendations. Example stencil design based on a 50% volumetric metal load solder paste. Refer to IPC-7525 for other stencil recommendations.
  - F. Customers should contact their board fabrication site for solder mask tolerances between and around signal pads.

PowerPAD is a trademark of Texas Instruments

## IMPORTANT NOTICE AND DISCLAIMER

TI PROVIDES TECHNICAL AND RELIABILITY DATA (INCLUDING DATASHEETS), DESIGN RESOURCES (INCLUDING REFERENCE DESIGNS), APPLICATION OR OTHER DESIGN ADVICE, WEB TOOLS, SAFETY INFORMATION, AND OTHER RESOURCES "AS IS" AND WITH ALL FAULTS, AND DISCLAIMS ALL WARRANTIES, EXPRESS AND IMPLIED, INCLUDING WITHOUT LIMITATION ANY IMPLIED WARRANTIES OF MERCHANTABILITY, FITNESS FOR A PARTICULAR PURPOSE OR NON-INFRINGEMENT OF THIRD PARTY INTELLECTUAL PROPERTY RIGHTS.

These resources are intended for skilled developers designing with TI products. You are solely responsible for (1) selecting the appropriate TI products for your application, (2) designing, validating and testing your application, and (3) ensuring your application meets applicable standards, and any other safety, security, or other requirements. These resources are subject to change without notice. TI grants you permission to use these resources only for development of an application that uses the TI products described in the resource. Other reproduction and display of these resources is prohibited. No license is granted to any other TI intellectual property right or to any third party intellectual property right. TI disclaims responsibility for, and you will fully indemnify TI and its representatives against, any claims, damages, costs, losses, and liabilities arising out of your use of these resources.

TI's products are provided subject to TI's Terms of Sale ([www.ti.com/legal/termsofsale.html](http://www.ti.com/legal/termsofsale.html)) or other applicable terms available either on [ti.com](http://ti.com) or provided in conjunction with such TI products. TI's provision of these resources does not expand or otherwise alter TI's applicable warranties or warranty disclaimers for TI products.

Mailing Address: Texas Instruments, Post Office Box 655303, Dallas, Texas 75265  
Copyright © 2019, Texas Instruments Incorporated

## Looking for pricing, stock, or lifecycle information?

Click below to explore more details on WIN SOURCE:

 [View UCC27423DRG4](#) on WIN SOURCE

 [Texas Instruments](#) Information

## Optimize Your Supply Chain with WIN SOURCE Solutions

-  Global Sourcing Solution
-  Obsolete Management
-  Cost Control Management
-  Shortage Management
-  Alternative Solution
-  Excess Inventory Management