



**THE DATASHEET OF
VN5E010MHTR-E**





VN5E010MH-E

Single-channel high-side driver with analog current sense for automotive applications

Features

Max supply voltage	V_{CC}	41 V
Operating voltage range	V_{CC}	4.5 V to 28 V
Typ. ON-state resistance	R_{ON}	10 m Ω
Current limitation (typ)	I_{LIMH}	85 A
OFF-state supply current	I_S	2 μ A ⁽¹⁾

1. Typical value with all loads connected.

- General
 - Inrush current active management by power limitation
 - Very low standby current
 - 3 V CMOS compatible inputs
 - Optimized electromagnetic emissions
 - Very low electromagnetic susceptibility
 - In compliance with the 2002/95/EC european directive
 - Very low current sense leakage
- Diagnostic functions
 - Proportional load current sense
 - High current sense precision for wide current range
 - Current sense disable
 - Output short to ground indication
 - Overload and short to ground (power limitation) indication
 - Thermal shutdown indication
- Protections
 - Undervoltage shutdown
 - Overvoltage clamp
 - Load current limitation
 - Self limiting of fast thermal transients
 - Protection against loss of ground and loss of V_{CC}
 - Overtemperature shutdown with autorestart (thermal shutdown)



- Reverse battery protection with self switch on of the Power MOSFET
- Electrostatic discharge protection

Application

- All types of resistive, inductive and capacitive loads

Description

The VN5E010MH-E is a single-channel high-side driver manufactured in the ST proprietary VIPower M0-5 technology and housed in the tiny HPak package. The VN5E010MH-E is designed to drive 12 V automotive grounded loads delivering protection, diagnostics and easy 3 V and 5 V CMOS compatible interface with any microcontroller.

The device integrates advanced protective functions such as load current limitation, inrush and overload active management by power limitation, overtemperature shut-off with auto restart and overvoltage active clamp.

A dedicated analog current sense pin is associated with every output channel in order to provide enhanced diagnostic functions including fast detection of overload and short-circuit to ground through power limitation indication and overtemperature indication.

The current sensing and diagnostic feedback of the whole device can be disabled by pulling the CS_DIS pin high to allow sharing of the external sense resistor with other similar devices.

Contents

- 1 Block diagram and pin configuration 5**
- 2 Electrical specifications 7**
 - 2.1 Absolute maximum ratings 7
 - 2.2 Thermal data 8
 - 2.3 Electrical characteristics 9
 - 2.4 Waveforms 17
 - 2.5 Electrical characteristics curves 19
 - 2.6 Application information 22
 - 2.7 Load dump protection 22
 - 2.8 MCU I/Os protection 22
 - 2.9 Current sense and diagnostic 23
 - 2.10 Maximum demagnetization energy ($V_{CC} = 13.5\text{ V}$) 24
- 3 Package and PC board thermal data 25**
 - 3.1 HPAK thermal data 25
- 4 Package and packing information 28**
 - 4.1 ECOPACK® 28
 - 4.2 HPAK mechanical data 28
 - 4.3 HPAK suggested land pattern 30
 - 4.4 Packing information 31
- 5 Order codes 32**
- 6 Revision history 33**

List of tables

Table 1.	Pin functions	5
Table 2.	Suggested connections for unused and not connected pins	6
Table 3.	Absolute maximum ratings	7
Table 4.	Thermal data	8
Table 5.	Power section	9
Table 6.	Switching ($V_{CC} = 13\text{ V}$, $T_j = 25\text{ °C}$)	9
Table 7.	Logic inputs	10
Table 8.	Protection and diagnostics	10
Table 9.	Current sense ($8\text{ V} < V_{CC} < 18\text{ V}$)	11
Table 10.	Truth table	15
Table 11.	Electrical transient requirements (part 1)	16
Table 12.	Electrical transient requirements (part 2)	16
Table 13.	Electrical transient requirements (part 3)	16
Table 14.	Thermal parameter	27
Table 15.	HPAK mechanical data	29
Table 16.	Device summary	32
Table 17.	Document revision history	33

List of figures

Figure 1.	Block diagram	5
Figure 2.	Configuration diagram (top view) not in scale.	6
Figure 3.	Current and voltage conventions	7
Figure 4.	Current sense delay characteristics	12
Figure 5.	Switching characteristics	13
Figure 6.	Delay response time between rising edge of output current and rising edge of current sense (CS enabled).	13
Figure 7.	Output voltage drop limitation.	14
Figure 8.	I_{OUT}/I_{SENSE} vs. I_{OUT}	14
Figure 9.	Maximum current sense ratio drift vs. load current ⁽¹⁾	15
Figure 10.	Normal operation	17
Figure 11.	Overload or short to GND.	17
Figure 12.	Intermittent overload	18
Figure 13.	T_J evolution in overload or short to GND	18
Figure 14.	OFF-state output current	19
Figure 15.	High-level input current.	19
Figure 16.	Input clamp voltage.	19
Figure 17.	Low-level input voltage	19
Figure 18.	High-level input voltage	19
Figure 19.	Input hysteresis voltage	19
Figure 20.	ON-state resistance vs. T_{case}	20
Figure 21.	ON-state resistance vs. V_{CC}	20
Figure 22.	Undervoltage shutdown	20
Figure 23.	Turn-on voltage slope	20
Figure 24.	I_{LIMH} vs. T_{case}	20
Figure 25.	Turn-off voltage slope	20
Figure 26.	High-level CS_DIS voltage	21
Figure 27.	CS_DIS clamp voltage	21
Figure 28.	Low-level CS_DIS voltage	21
Figure 29.	Application schematic	22
Figure 30.	Current sense and diagnostic	23
Figure 31.	Maximum turn-off current versus inductance ⁽¹⁾	24
Figure 32.	PC board ⁽¹⁾	25
Figure 33.	$R_{thj-amb}$ vs. PCB copper area in open box free air condition	25
Figure 34.	HPAK thermal impedance junction ambient single pulse	26
Figure 35.	Thermal fitting model of a single-channel HSD in HPAK ⁽¹⁾	26
Figure 36.	HPAK package dimension	28
Figure 37.	HPAK suggested pad layout ⁽¹⁾	30
Figure 38.	HPAK tube shipment (no suffix)	31
Figure 39.	HPAK tape and reel (suffix "TR")	31

1 Block diagram and pin configuration

Figure 1. Block diagram

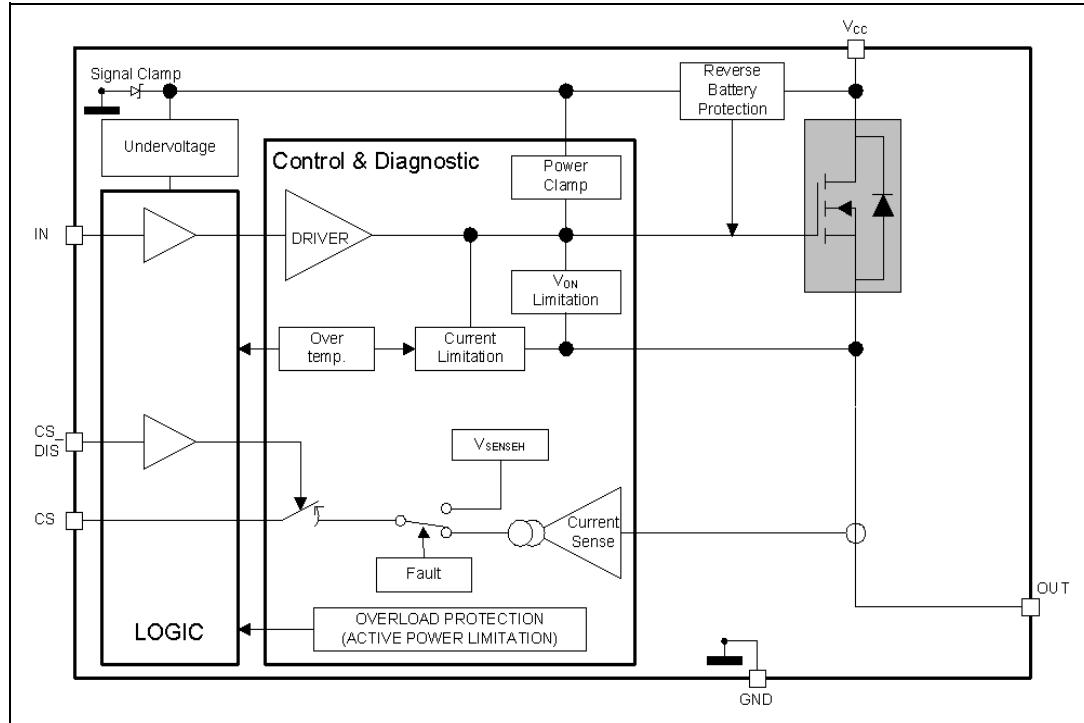

Table 1. Pin functions

Name	Function
V _{CC}	Battery connection
OUT	Power output ⁽¹⁾
GND	Ground connection
IN	Voltage controlled input pin with hysteresis, CMOS compatible. Controls output switch state
CS	Analog current sense pin, delivers a current proportional to the load current
CS_DIS	Active high CMOS compatible pin, to disable the current sense pin

1. Pins 1 and 7 must be externally tied together.

Figure 2. Configuration diagram (top view) not in scale

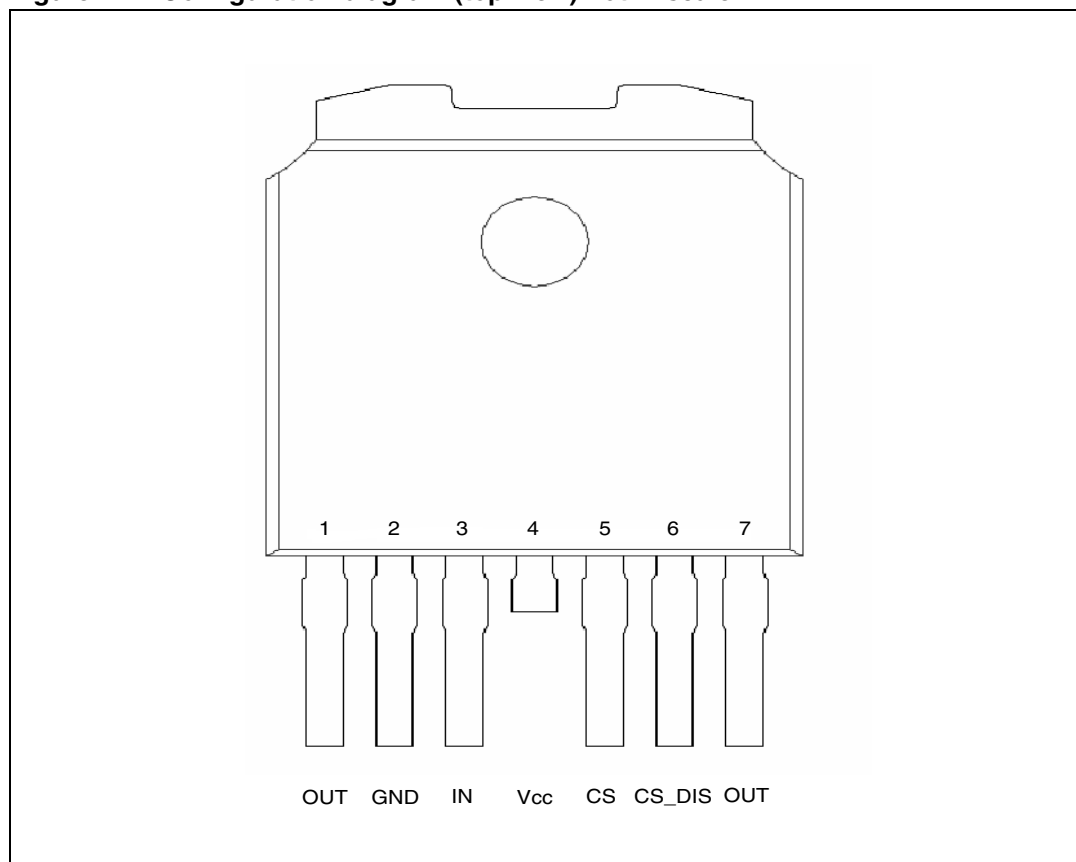
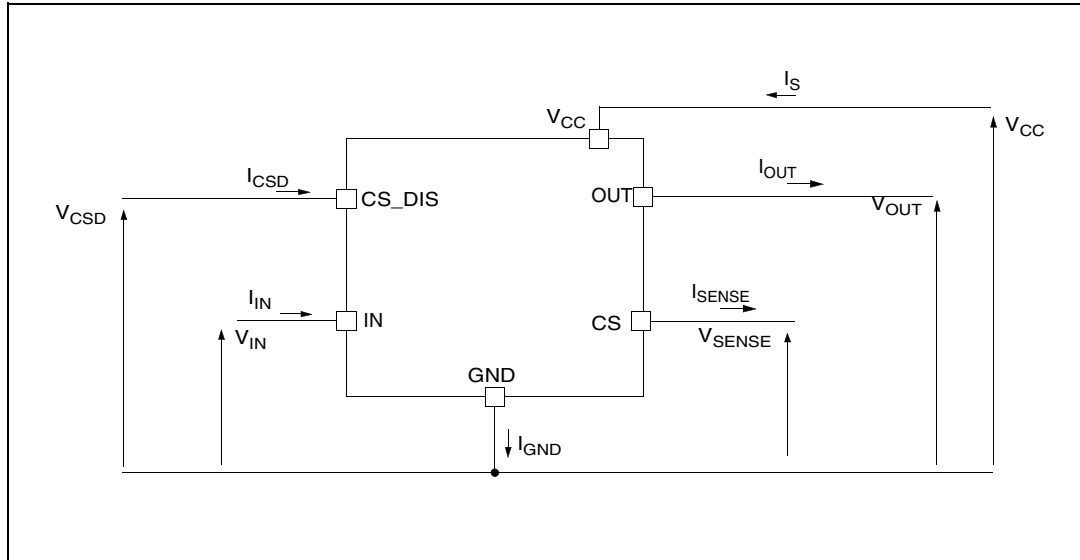

Table 2. Suggested connections for unused and not connected pins

Connection / pin	CS	OUT	IN	CS_DIS
Floating	Not allowed	X	X	X
To ground	Through 1kΩ resistor	Through 22 kΩ resistor	Through 10 kΩ resistor	Through 10 kΩ resistor

2 Electrical specifications

Figure 3. Current and voltage conventions



2.1 Absolute maximum ratings

Stressing the device above the rating listed in the [Table 3: Absolute maximum ratings](#) may cause permanent damage to the device. These are stress ratings only and operation of the device at these or any other conditions above those indicated in the operating sections of this specification is not implied. Exposure to absolute maximum rating conditions for extended periods may affect device reliability. Refer also to the STMicroelectronics SURE program and other relevant quality document.

Table 3. Absolute maximum ratings

Symbol	Parameter	Value	Unit
V _{CC}	DC supply voltage	41	V
-V _{CC}	Reverse DC supply voltage	16	V
I _{OUT}	DC output current	Internally limited	A
-I _{OUT}	Reverse DC output current	20	A
I _{IN}	DC input current	-1 to 10	mA
I _{CS_DIS}	DC current sense disable input current	-1 to 10	mA
V _{CS_SENSE}	Current sense maximum voltage (V _{CC} > 0)	V _{CC} - 41 +V _{CC}	V V
E _{MAX}	Maximum switching energy (single pulse) (L = 2.2 mH; R _L = 0 Ω; V _{BAT} = 13.5 V; T _{jstart} = 150 °C; I _{OUT} = I _{limL} (Typ.))	645	mJ

Table 3. Absolute maximum ratings (continued)

Symbol	Parameter	Value	Unit
V _{ESD}	Electrostatic discharge (human body model: R= 1.5 KΩ; C= 100 pF)		
	– IN	4000	V
	– CS	2000	V
	– CS_DIS	4000	V
	– OUT	5000	V
	– V _{CC}	5000	V
V _{ESD}	Charge device model (CDM-AEC-Q100-011)	750	V
T _j	Junction operating temperature	-40 to 150	°C
T _{stg}	Storage temperature	-55 to 150	°C

2.2 Thermal data

Table 4. Thermal data

Symbol	Parameter	Max. value	Unit
R _{thj-case}	Thermal resistance junction-case	0.55	°C/W
R _{thj-amb}	Thermal resistance junction-ambient	67.7	°C/W

2.3 Electrical characteristics

Values specified in this section are for $8\text{ V} < V_{CC} < 28\text{ V}$, $-40\text{ °C} < T_j < 150\text{ °C}$, unless otherwise specified.

Table 5. Power section

Symbol	Parameter	Test conditions	Min.	Typ.	Max.	Unit
V_{CC}	Operating supply voltage		4.5	13	28	V
V_{USD}	Undervoltage shutdown			3.5	4.5	V
$V_{USDhyst}$	Undervoltage shutdown hysteresis			0.5		V
R_{ON}	ON-state resistance	$I_{OUT} = 6\text{ A}$; $T_j = 25\text{ °C}$		10		m Ω
		$I_{OUT} = 6\text{ A}$; $T_j = 150\text{ °C}$			20	
		$I_{OUT} = 6\text{ A}$; $V_{CC} = 5\text{ V}$; $T_j = 25\text{ °C}$			13	
R_{ON-Rev}	$R_{DS(on)}$ in reverse battery condition	$V_{CC} = -13\text{ V}$; $I_{OUT} = -6\text{ A}$; $T_j = 25\text{ °C}$		10		m Ω
V_{clamp}	Clamp voltage	$I_{CC} = 20\text{ mA}$; $I_{OUT} = 0\text{ A}$	41	46	52	V
I_S	Supply current	OFF-state: $V_{CC} = 13\text{ V}$; $T_j = 25\text{ °C}$; $V_{IN} = V_{OUT} = V_{SENSE} = 0\text{ V}$		2	5	μA
		ON-state: $V_{CC} = 13\text{ V}$; $V_{IN} = 5\text{ V}$; $I_{OUT} = 0\text{ A}$		1.5	3	mA
$I_{L(off)}$	OFF-state output current	$V_{IN} = V_{OUT} = 0\text{ V}$; $V_{CC} = 13\text{ V}$; $T_j = 25\text{ °C}$	0	0.01	3	μA
		$V_{IN} = V_{OUT} = 0\text{ V}$; $V_{CC} = 13\text{ V}$; $T_j = 125\text{ °C}$	0		5	

Table 6. Switching ($V_{CC} = 13\text{ V}$, $T_j = 25\text{ °C}$)

Symbol	Parameter	Test conditions	Min.	Typ.	Max.	Unit
$t_{d(on)}$	Turn-on delay time	$R_L = 2.2\ \Omega$ (see Figure 5)	-	40	-	μs
$t_{d(off)}$	Turn-off delay time	$R_L = 2.2\ \Omega$ (see Figure 5)	-	28	-	μs
$(dV_{OUT}/dt)_{on}$	Turn-on voltage slope	$R_L = 2.2\ \Omega$	-	(see Figure 23)	-	V/ μs
$(dV_{OUT}/dt)_{off}$	Turn-off voltage slope	$R_L = 2.2\ \Omega$	-	(see Figure 25)	-	V/ μs
W_{ON}	Switching energy losses at turn-on (t_{won})	$R_L = 2.2\ \Omega$ (see Figure 5)	-	2	-	mJ
W_{OFF}	Switching energy losses at turn-off (t_{woff})	$R_L = 2.2\ \Omega$ (see Figure 5)	-	0.6	-	mJ

Table 7. Logic inputs

Symbol	Parameter	Test conditions	Min.	Typ.	Max.	Unit
V_{IL}	Low-level input voltage				0.9	V
I_{IL}	Low-level input current	$V_{IN} = 0.9\text{ V}$	1			μA
V_{IH}	High-level input voltage		2.1			V
I_{IH}	High-level input current	$V_{IN} = 2.1\text{ V}$			10	μA
$V_{I(hyst)}$	Input hysteresis voltage		0.25			V
V_{ICL}	Input clamp voltage	$I_{IN} = 1\text{ mA}$	5.5		7	V
		$I_{IN} = -1\text{ mA}$		-0.7		
V_{CSDL}	Low-level CS_DIS voltage				0.9	V
I_{CSDL}	Low-level CS_DIS current	$V_{CSD} = 0.9\text{ V}$	1			μA
V_{CSDH}	High-level CS_DIS voltage		2.1			V
I_{CSDH}	High-level CS_DIS current	$V_{CSD} = 2.1\text{ V}$			10	μA
$V_{CSD(hyst)}$	CS_DIS hysteresis voltage		0.25			V
V_{CSCL}	CS_DIS clamp voltage	$I_{CSD} = 1\text{ mA}$	5.5		7	V
		$I_{CSD} = -1\text{ mA}$		-0.7		

Table 8. Protection and diagnostics⁽¹⁾

Symbol	Parameter	Test conditions	Min.	Typ.	Max.	Unit
I_{limH}	Short-circuit current	$V_{CC} = 13\text{ V}$	60	85	120	A
		$5\text{ V} < V_{CC} < 28\text{ V}$			120	
I_{limL}	Short-circuit current during thermal cycling	$V_{CC} = 13\text{ V}; T_R < T_j < T_{TSD}$		21		A
T_{TSD}	Shutdown temperature		150	175	200	$^{\circ}\text{C}$
T_R	Reset temperature		$T_{RS} + 1$	$T_{RS} + 5$		$^{\circ}\text{C}$
T_{RS}	Thermal reset of status		135			$^{\circ}\text{C}$
T_{HYST}	Thermal hysteresis ($T_{TSD} - T_R$)			7		$^{\circ}\text{C}$
V_{DEMAG}	Turn-off output voltage clamp	$I_{OUT} = 2\text{ A}; V_{IN} = 0;$ $L = 6\text{ mH}$	$V_{CC} - 41$	$V_{CC} - 46$	$V_{CC} - 52$	V
V_{ON}	Output voltage drop limitation	$I_{OUT} = 0.5\text{ A};$ $T_j = -40\text{ }^{\circ}\text{C} \text{ to } 150\text{ }^{\circ}\text{C}$		25		mV

1. To ensure long term reliability under heavy overload or short-circuit conditions, protection and related diagnostic signals must be used together with a proper software strategy. If the device is subjected to abnormal conditions, this software must limit the duration and number of activation cycles.

Table 9. Current sense (8 V < V_{CC} < 18 V)

Symbol	Parameter	Test conditions	Min.	Typ.	Max.	Unit
K ₀	I _{OUT} /I _{SENSE}	I _{OUT} = 0.25 A; V _{SENSE} = 0.5 V T _j = -40 °C to 150 °C T _j = 25 °C to 150 °C	3000 3000	7410 7410	12000 11600	
K ₁	I _{OUT} /I _{SENSE}	I _{OUT} = 6 A; V _{SENSE} = 0.5 V T _j = -40 °C to 150 °C T _j = 25 °C to 150 °C	5350 5510	6740 6740	8500 7745	
dK ₁ /K ₁ ⁽¹⁾	Current sense ratio drift	I _{OUT} = 6 A; V _{SENSE} = 0.5 V; V _{CSD} = 0 V; T _j = -40 °C to 150 °C	-15		15	%
K ₂	I _{OUT} /I _{SENSE}	I _{OUT} = 10 A; V _{SENSE} = 4 V T _j = -40 °C to 150 °C T _j = 25 °C to 150 °C	5850 5800	6570 6570	7690 7195	
dK ₂ /K ₂ ⁽¹⁾	Current sense ratio drift	I _{OUT} = 10 A; V _{SENSE} = 4 V; V _{CSD} = 0 V; T _j = -40 °C to 150 °C	-11		11	%
K ₃	I _{OUT} /I _{SENSE}	I _{OUT} = 25 A; V _{SENSE} = 4 V T _j = -40 °C to 150 °C T _j = 25 °C to 150 °C	5915 5850	6420 6420	7000 6755	
dK ₃ /K ₃ ⁽¹⁾	Current sense ratio drift	I _{OUT} = 25 A; V _{SENSE} = 4 V; V _{CSD} = 0 V; T _j = -40 °C to 150 °C	-8		8	%
I _{SENSE0}	Analog sense leakage current	I _{OUT} = 0 A; V _{SENSE} = 0 V; V _{CSD} = 5 V; V _{IN} = 0 V; T _j = -40 °C to 150 °C	0		1	μA
		I _{OUT} = 0 A; V _{SENSE} = 0 V; V _{CSD} = 0 V; V _{IN} = 5 V; T _j = -40 °C to 150 °C	0		2	
		I _{OUT} = 2 A; V _{SENSE} = 0 V; V _{CSD} = 5 V; V _{IN} = 5 V; T _j = -40 °C to 150 °C			1	
I _{OL}	Open load ON-state current detection threshold	V _{IN} = 5 V, 8 V < V _{CC} < 18 V I _{SENSE} = 5 μA	5		80	mA
V _{SENSE}	Max analog sense output voltage	I _{OUT} = 18 A; R _{SENSE} = 3.9 kΩ	5			V
V _{SENSEH} ⁽²⁾	Analog sense output voltage in fault condition	V _{CC} = 13 V; R _{SENSE} = 3.9 kΩ		8		V
I _{SENSEH} ⁽²⁾	Analog sense output current in fault condition	V _{CC} = 13 V; V _{SENSE} = 5 V		9		mA

Table 9. Current sense (8 V < V_{CC} < 18 V) (continued)

Symbol	Parameter	Test conditions	Min.	Typ.	Max.	Unit
t _{DSENSE1H}	Delay response time from falling edge of CS_DIS pin	V _{SENSE} < 4 V, 1.5 A < I _{OUT} < 25 A I _{SENSE} = 90% of I _{SENSE MAX} (see Figure 4)		50	100	μs
t _{DSENSE1L}	Delay response time from rising edge of CS_DIS pin	V _{SENSE} < 4 V, 1.5 A < I _{OUT} < 25 A I _{SENSE} = 10% of I _{SENSE MAX} (see Figure 4)		5	20	μs
t _{DSENSE2H}	Delay response time from rising edge of IN pin	V _{SENSE} < 4 V, 1.5 A < I _{OUT} < 25 A I _{SENSE} = 90% of I _{SENSE max} (see Figure 4)		270	600	μs
Δt _{DSENSE2H}	Delay response time between rising edge of output current and rising edge of current sense	V _{SENSE} < 4V, I _{SENSE} = 90% of I _{SENSEMAX} , I _{OUT} = 90% of I _{OUTMAX} I _{OUTMAX} = 3 A (see Figure 6)			310	μs
t _{DSENSE2L}	Delay response time from falling edge of IN pin	V _{SENSE} < 4 V, 1.5 A < I _{OUT} < 25 A I _{SENSE} = 10% of I _{SENSE max} (see fig Figure 4)		100	250	μs

1. Parameter guaranteed by design, it is not tested.
2. Fault condition includes: power limitation and overtemperature.

Figure 4. Current sense delay characteristics

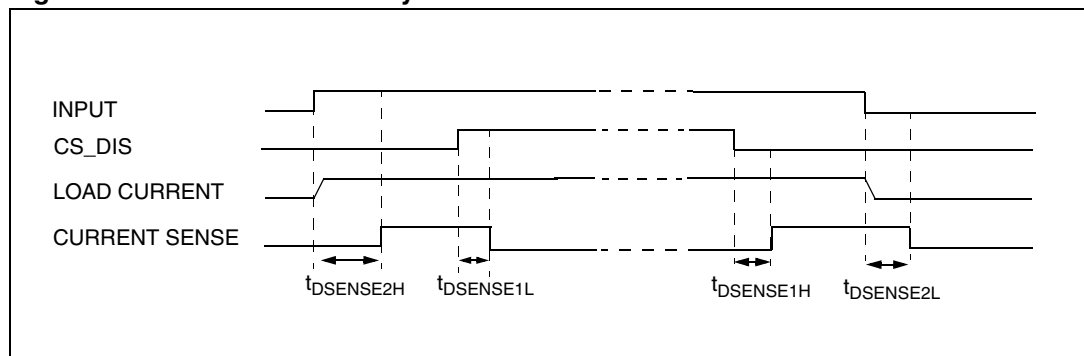

Figure 5. Switching characteristics

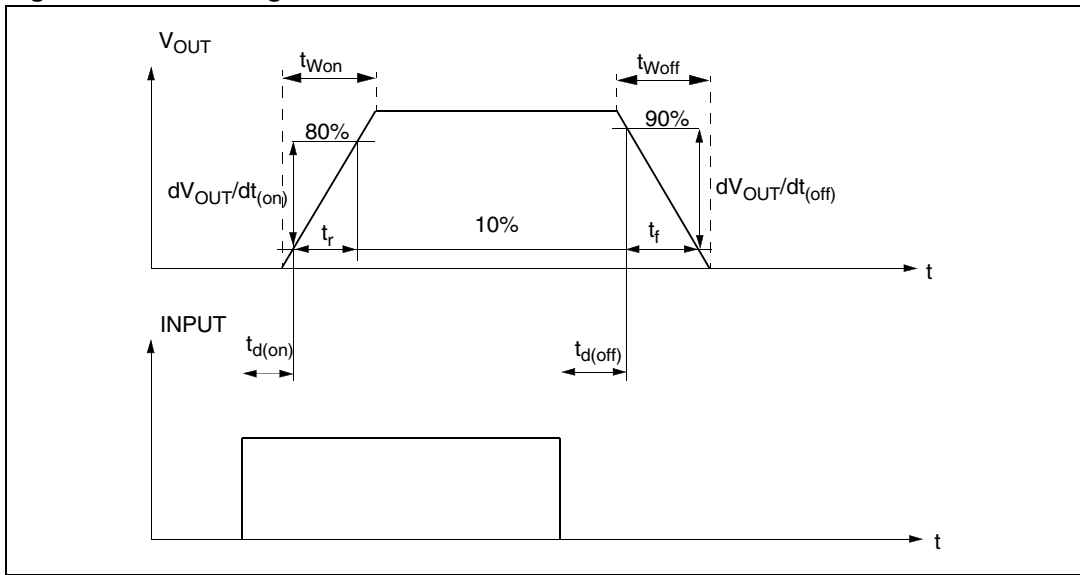

Figure 6. Delay response time between rising edge of output current and rising edge of current sense (CS enabled)

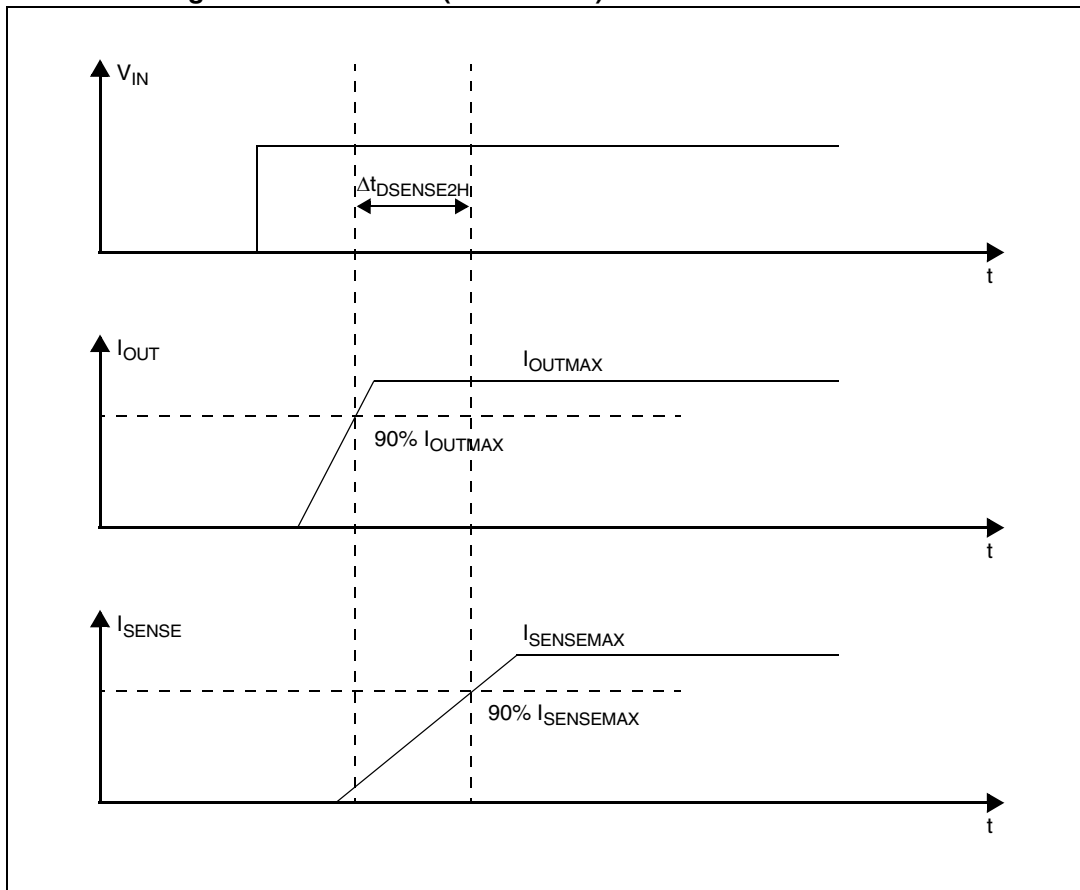

Figure 7. Output voltage drop limitation

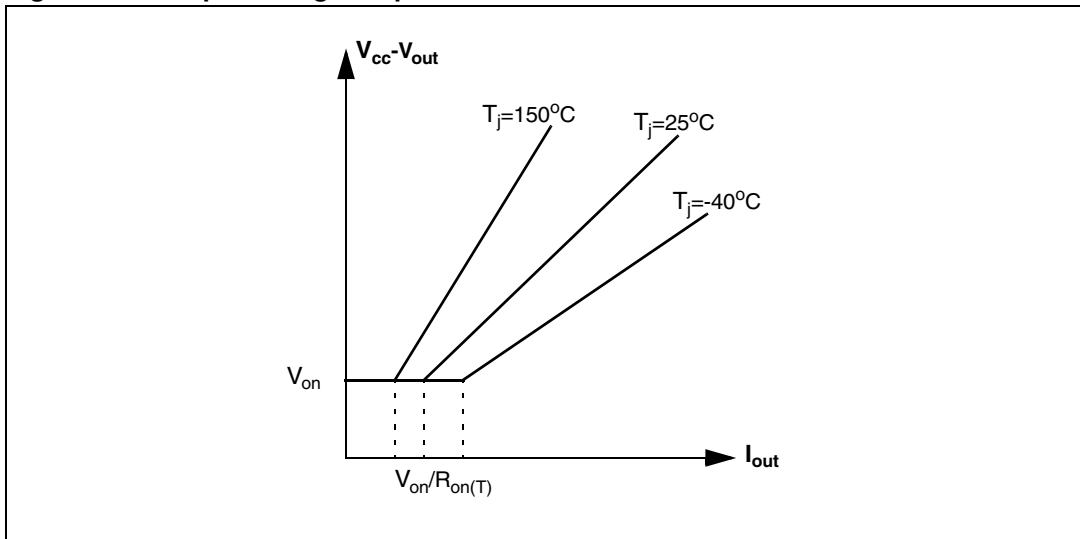

Figure 8. I_{OUT}/I_{SENSE} vs. I_{OUT}

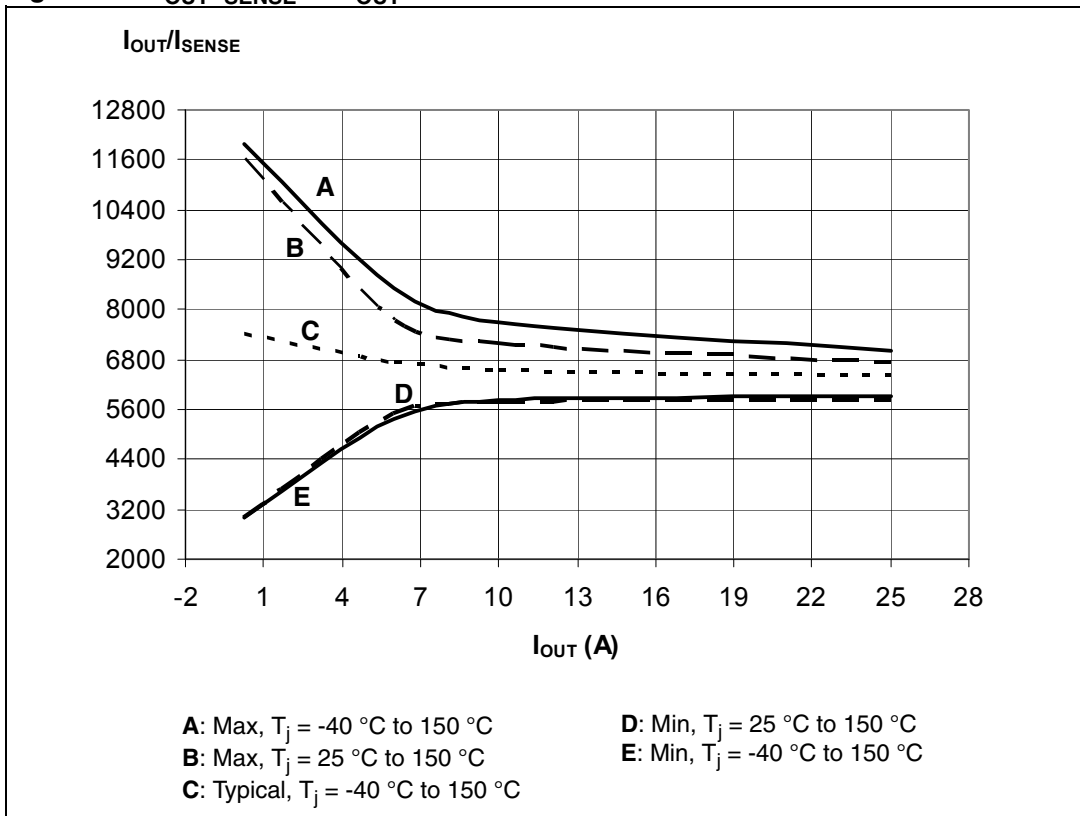
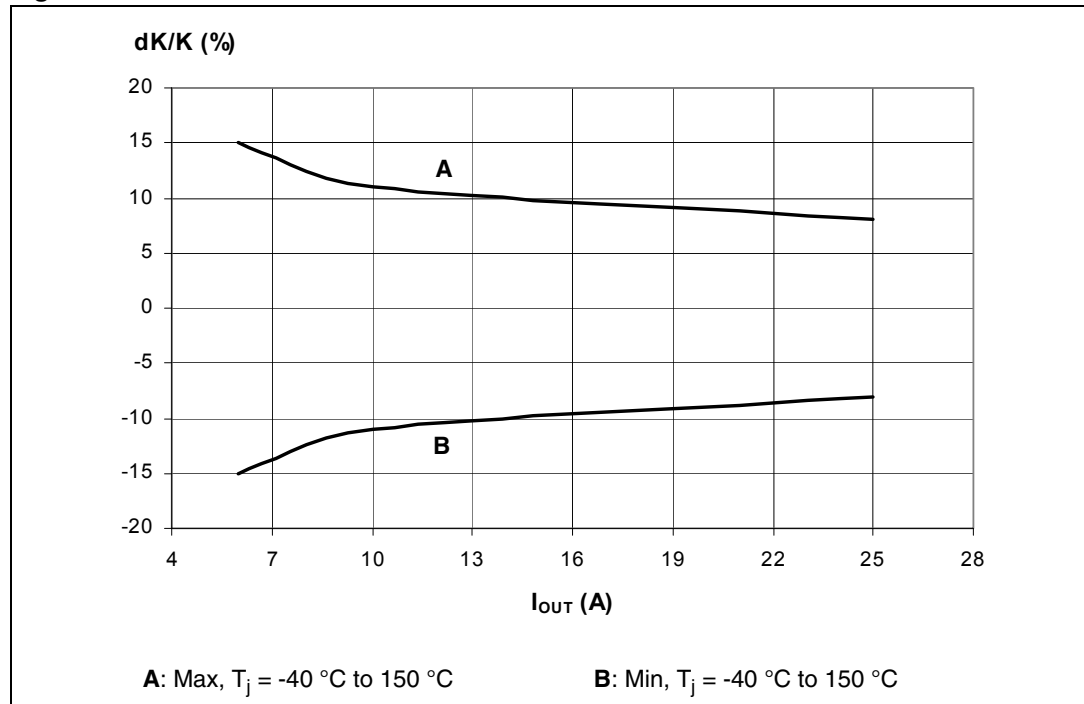

Figure 9. Maximum current sense ratio drift vs. load current⁽¹⁾



1. Parameter guaranteed by design; it is not tested.

Table 10. Truth table

Conditions	Input	Output	SENSE (V _{CSD} = 0 V) ⁽¹⁾
Normal operation	L	L	0
	H	H	Nominal
Overtemperature	L	L	0
	H	L	V _{SENSEH}
Undervoltage	L	L	0
	H	L	0
Overload	H	X (no power limitation)	Nominal
	H	Cycling (power limitation)	V _{SENSEH}
Short-circuit to GND (power limitation)	L	L	0
	H	L	V _{SENSEH}
Negative output voltage clamp	L	L	0

1. If the V_{CSD} is high, the SENSE output is at a high-impedance, its potential depends on leakage currents and external circuit.

Table 11. Electrical transient requirements (part 1)

ISO 7637-2: 2004(E) Test pulse	Test levels ⁽¹⁾		Number of pulses or test times	Burst cycle/pulse repetition time		Delays and impedance
	III	IV		Min.	Max.	
1	-75 V	-100 V	5000 pulses	0.5 s	5 s	2 ms, 10 Ω
2a	+37 V	+50 V	5000 pulses	0.2 s	5 s	50 μs, 2 Ω
3a	-100 V	-150 V	1 h	90 ms	100 ms	0.1μs, 50 Ω
3b	+75 V	+100 V	1 h	90 ms	100 ms	0.1μs, 50 Ω
4	-6 V	-7 V	1 pulse			100 ms, 0.01 Ω
5b ⁽²⁾	+65 V	+87 V	1 pulse			400 ms, 2 Ω

1. The above test levels must be considered referred to $V_{CC} = 13.5$ V except for pulse 5b.
2. Valid in case of external load dump clamp: 40 V maximum referred to ground.

Table 12. Electrical transient requirements (part 2)

ISO 7637-2: 2004(E) Test pulse	Test level results	
	III	IV
1	C	C
2a	C	C
3a	C	C
3b	C	C
4	C	C
5b ⁽¹⁾	C	C

1. Valid in case of external load dump clamp: 40 V maximum referred to ground.

Table 13. Electrical transient requirements (part 3)

Class	Contents
C	All functions of the device are performed as designed after exposure to disturbance.
E	One or more functions of the device are not performed as designed after exposure to disturbance and cannot be returned to proper operation without replacing the device.

2.4 Waveforms

Figure 10. Normal operation

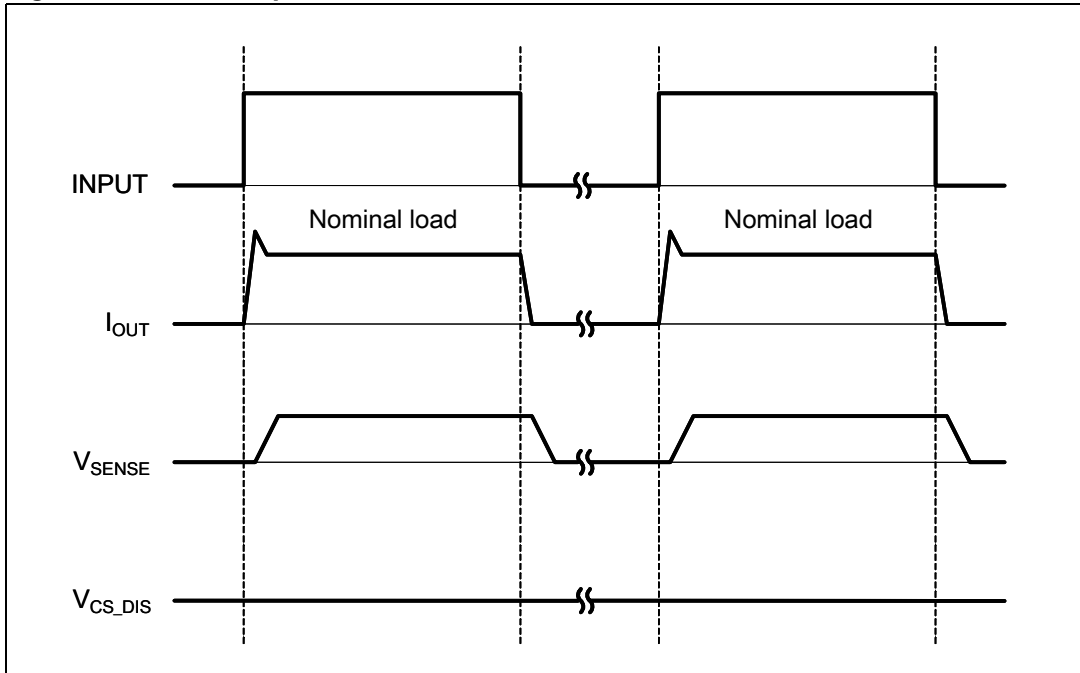

Figure 11. Overload or short to GND

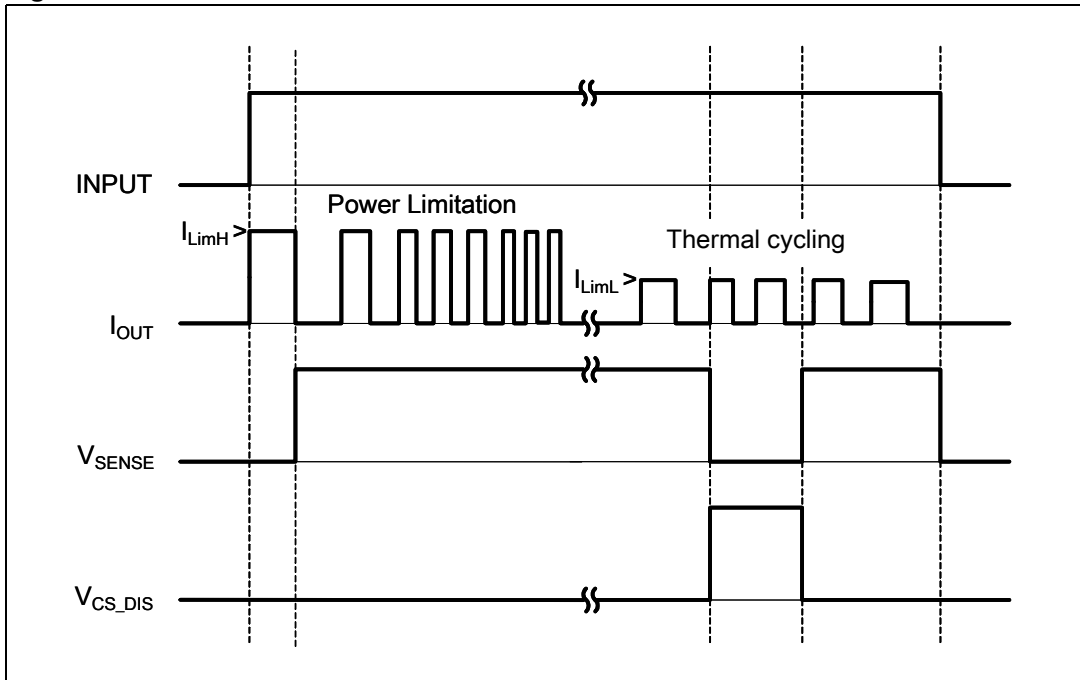

Figure 12. Intermittent overload

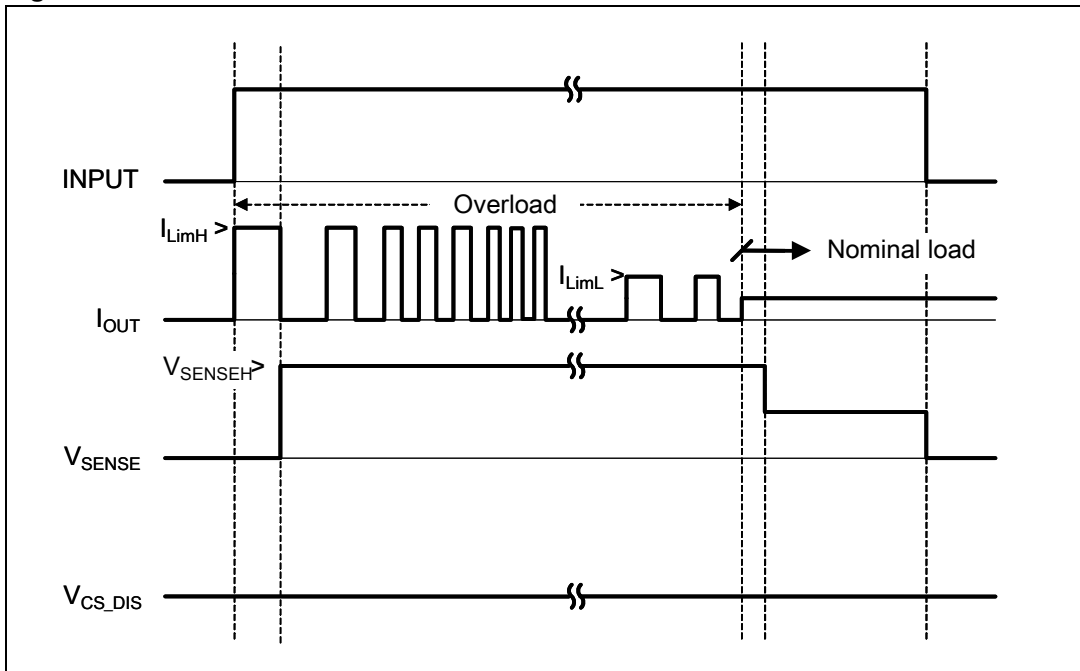
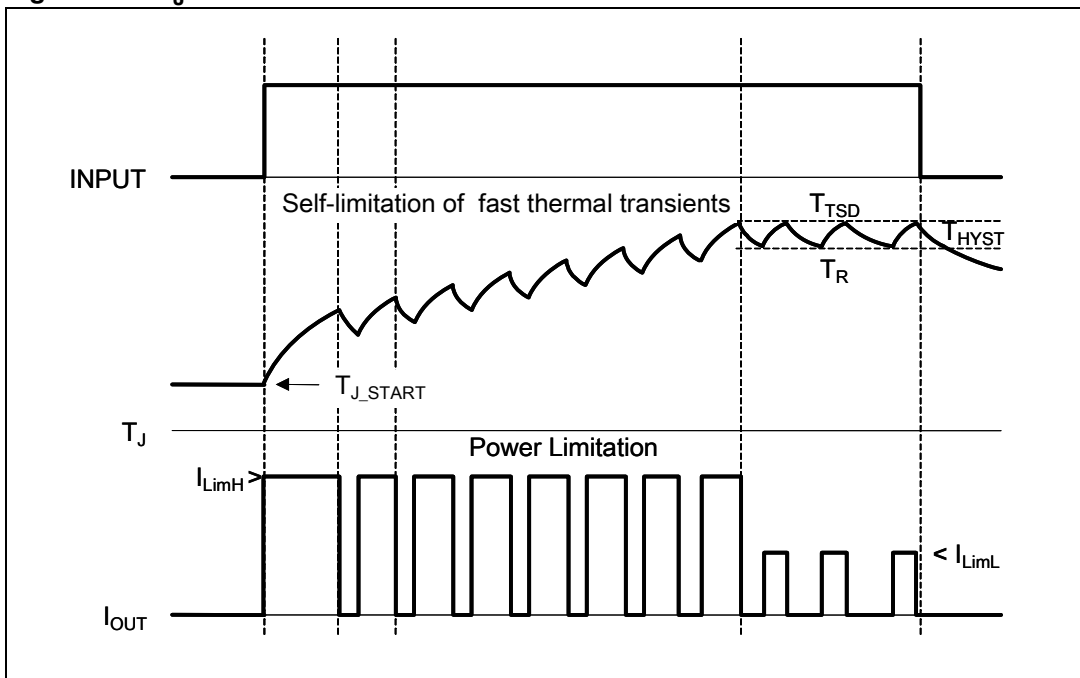

Figure 13. T_J evolution in overload or short to GND



2.5 Electrical characteristics curves

Figure 14. OFF-state output current

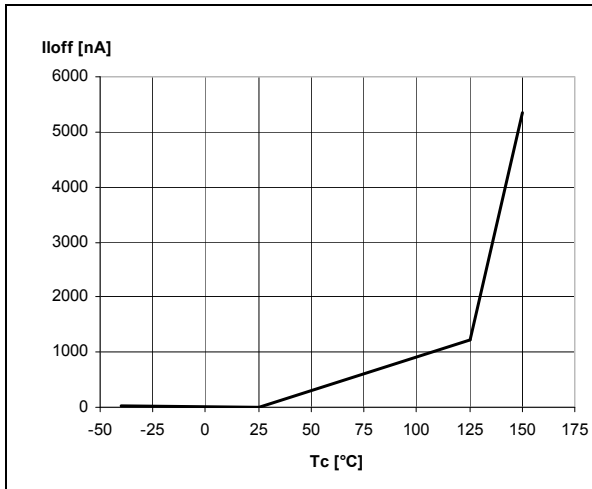

Figure 15. High-level input current

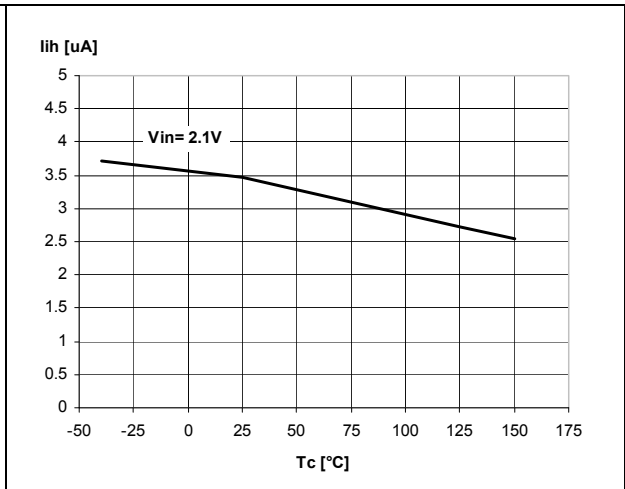

Figure 16. Input clamp voltage

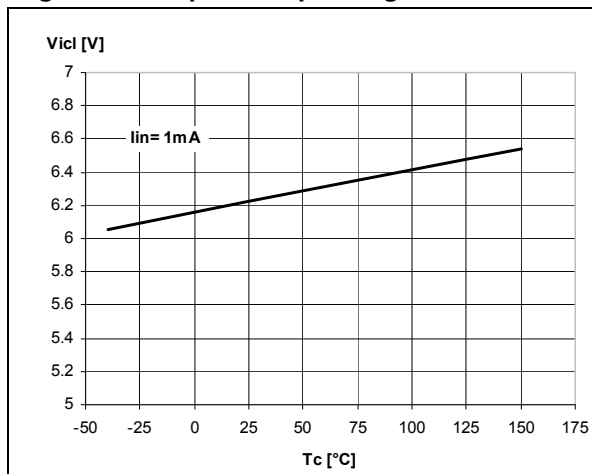

Figure 17. Low-level input voltage

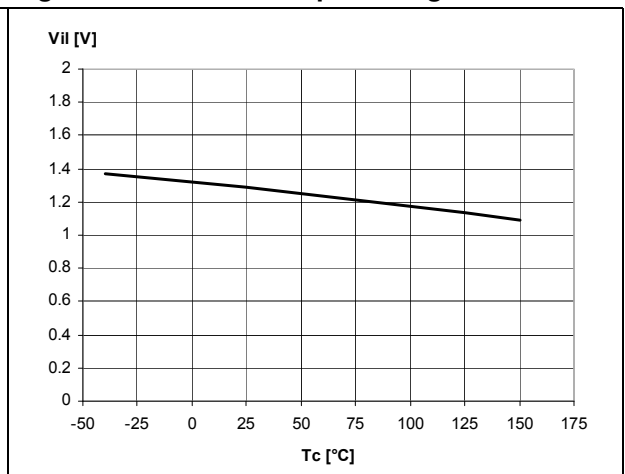

Figure 18. High-level input voltage

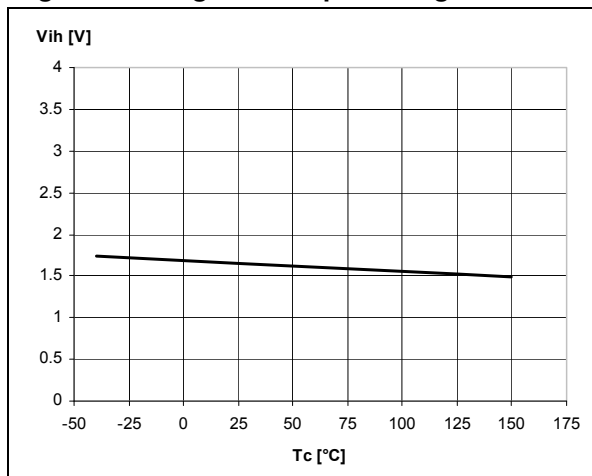

Figure 19. Input hysteresis voltage

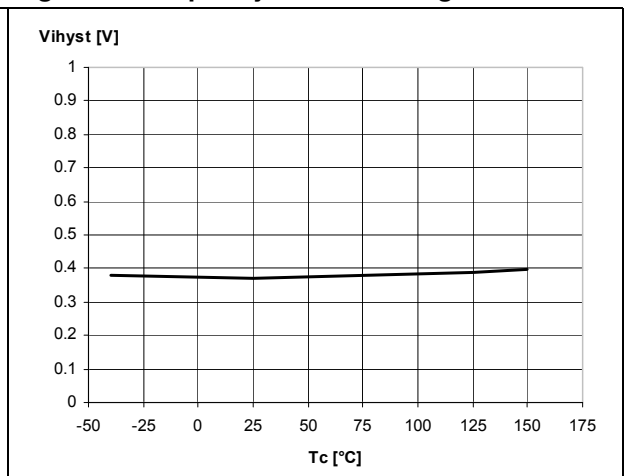

Figure 20. ON-state resistance vs. T_{case}

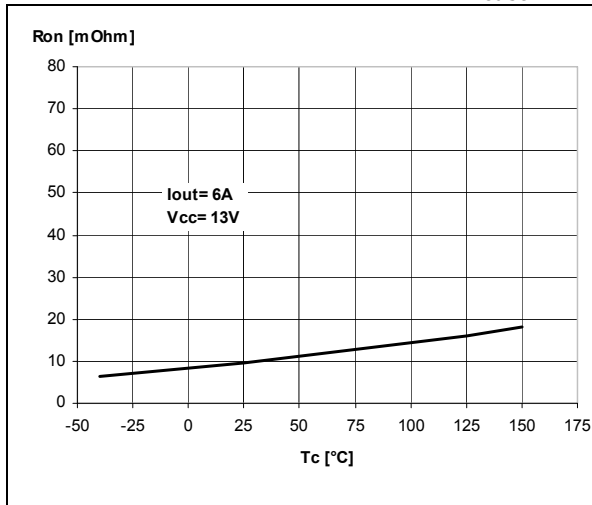

Figure 21. ON-state resistance vs. V_{CC}

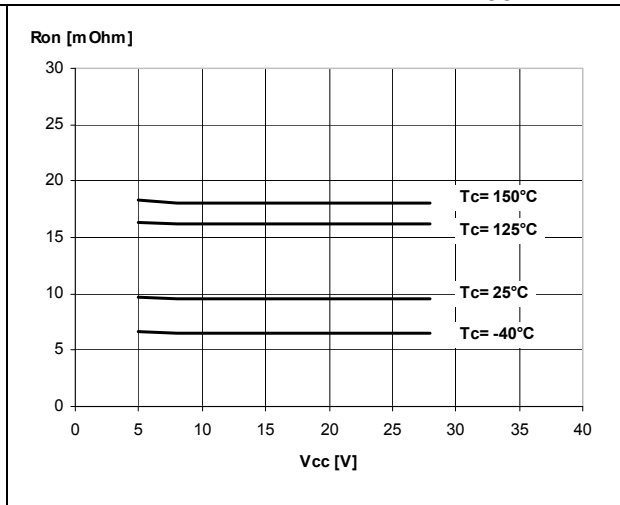

Figure 22. Undervoltage shutdown

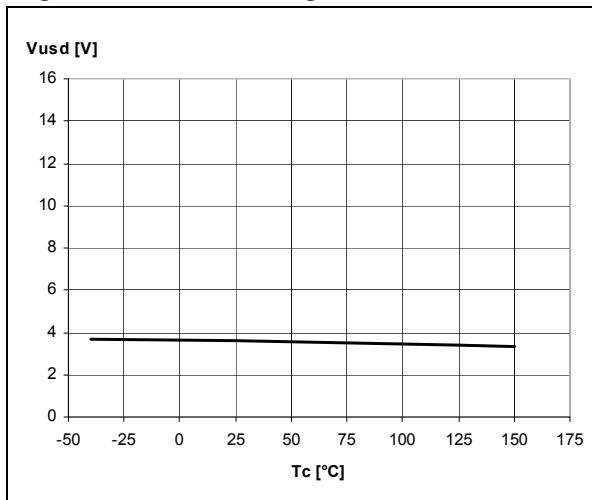

Figure 23. Turn-on voltage slope

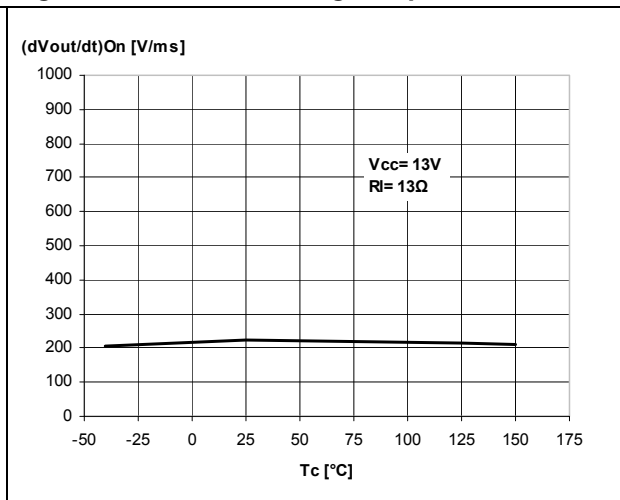

Figure 24. I_{LIMH} vs. T_{case}

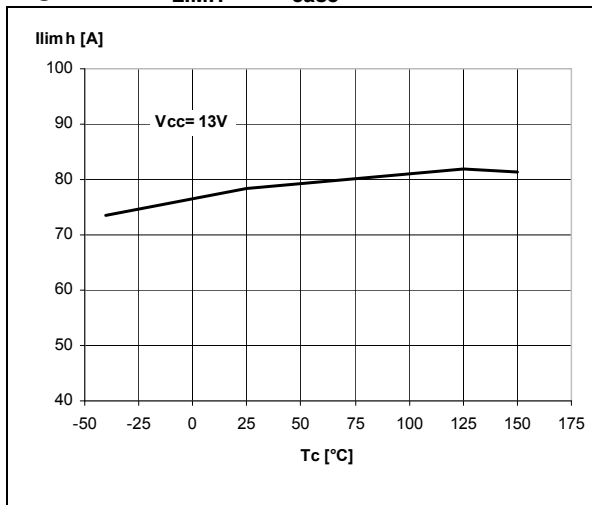

Figure 25. Turn-off voltage slope

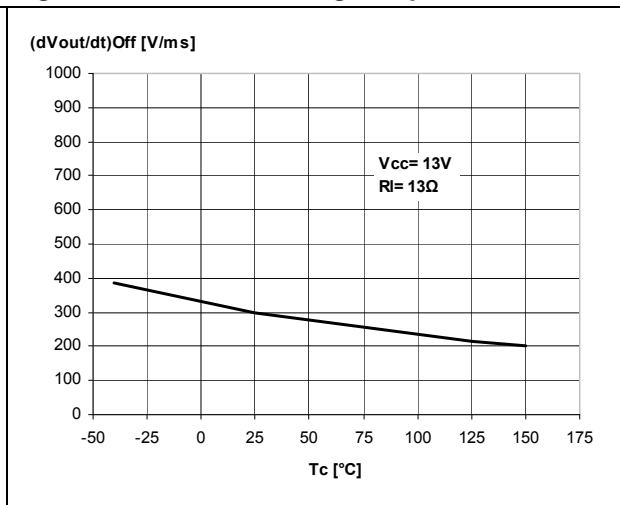

Figure 26. High-level CS_DIS voltage

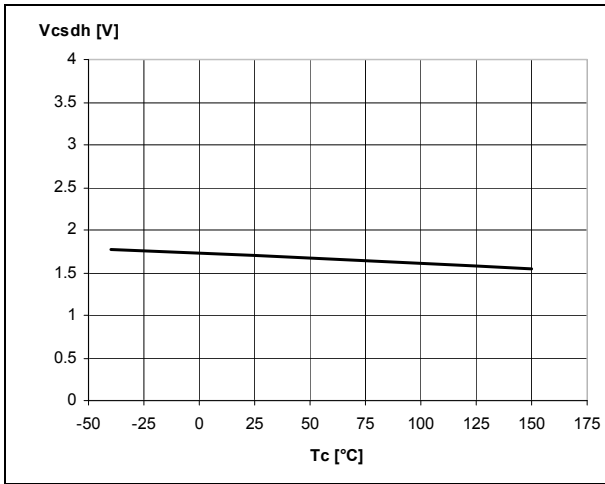

Figure 27. CS_DIS clamp voltage

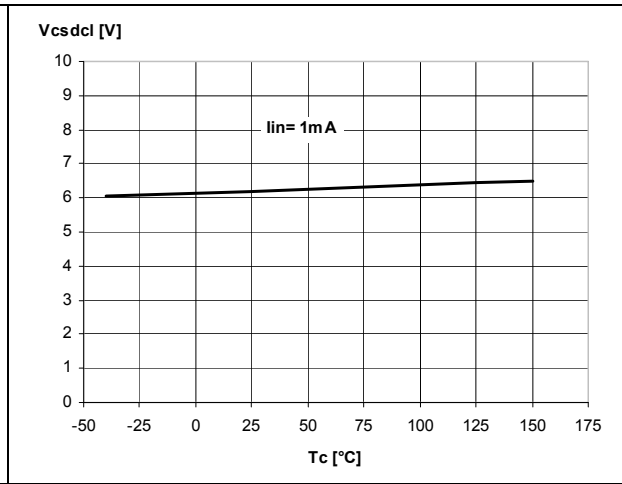
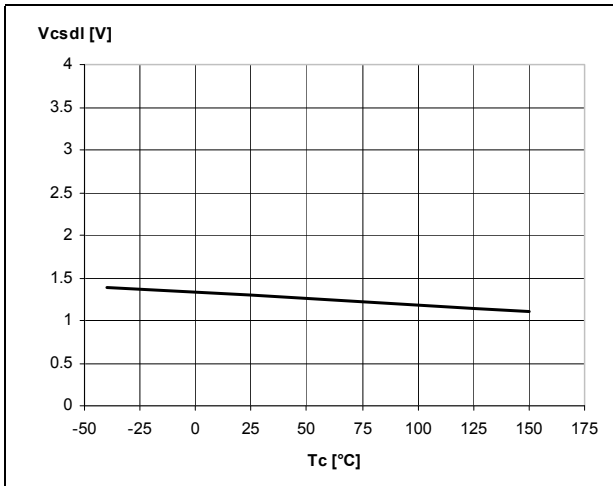
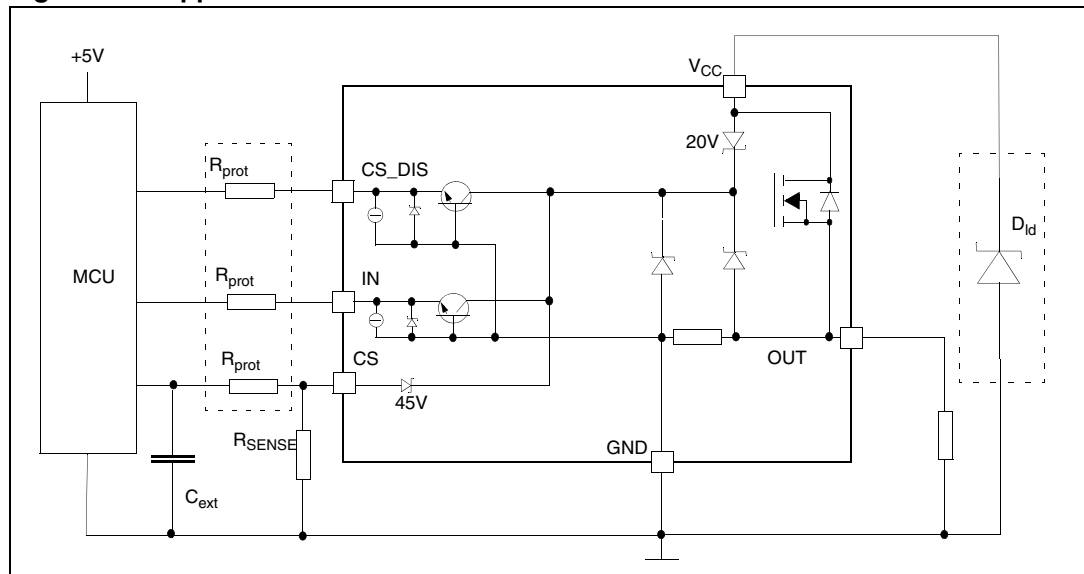

Figure 28. Low-level CS_DIS voltage



2.6 Application information

Figure 29. Application schematic



2.7 Load dump protection

D_{ld} is necessary (voltage transient suppressor) if the load dump peak voltage exceeds the V_{CC} max DC rating. The same applies if the device is subject to transients on the V_{CC} line that are greater than the ones shown in the ISO 7637-2 2004 (E) table.

2.8 MCU I/Os protection

When negative transients are present on the V_{CC} line, the control pins are pulled negative to approximately -1.5 V. ST suggests to insert a resistor (R_{prot}) in line to prevent the microcontroller I/Os pins to latch-up.

The value of these resistors is a compromise between the leakage current of microcontroller and the current required by the HSD I/Os (input levels compatibility) with the latch-up limit of microcontroller I/Os.

Equation 1

$$-V_{CCpeak} / I_{latchup} \leq R_{prot} \leq (V_{OH\mu C} - V_{IH}) / I_{IHmax}$$

Calculation example:

For $V_{CCpeak} = -1.5$ V; $I_{latchup} \geq 20$ mA; $V_{OH\mu C} \geq 4.5$ V

$$75 \Omega \leq R_{prot} \leq 240 \text{ k}\Omega$$

Recommended values: $R_{prot} = 10$ k Ω , $C_{EXT} = 10$ nF.

2.9 Current sense and diagnostic

The current sense pin performs a double function (see [Figure 30: Current sense and diagnostic](#)):

- **Current mirror of the load current in normal operation**, delivering a current proportional to the load one according to a know ratio K_x .
The current I_{SENSE} can be easily converted to a voltage V_{SENSE} by means of an external resistor R_{SENSE} . Linearity between I_{OUT} and V_{SENSE} is ensured up to 5 V minimum (see parameter V_{SENSE} in [Table 9: Current sense \(8 V < \$V_{CC}\$ < 18 V\)](#)). The current sense accuracy depends on the output current (refer to current sense electrical characteristics [Table 9: Current sense \(8 V < \$V_{CC}\$ < 18 V\)](#)).
- **Diagnostic flag in fault conditions**, delivering a fixed voltage V_{SENSEH} up to a maximum current I_{SENSEH} in case of the following fault conditions (refer to [Table 10: Truth table](#)):
 - Power limitation activation
 - Overtemperature

A logic level high on CS_DIS pin sets at the same time all the current sense pins of the device in a high-impedance state, thus disabling the current monitoring and diagnostic detection. This feature allows multiplexing of the microcontroller analog inputs by sharing of sense resistance and ADC line among different devices.

Figure 30. Current sense and diagnostic

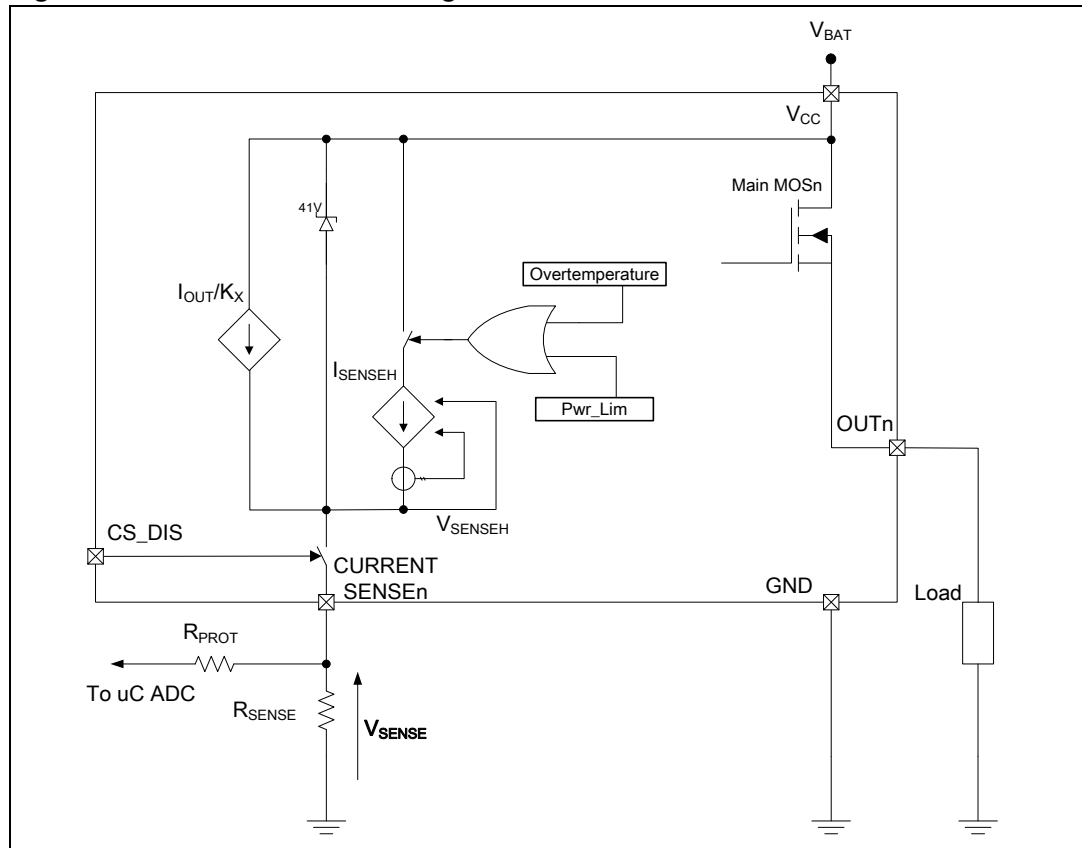

2.10 Maximum demagnetization energy ($V_{CC} = 13.5\text{ V}$)

Figure 31. Maximum turn-off current versus inductance⁽¹⁾

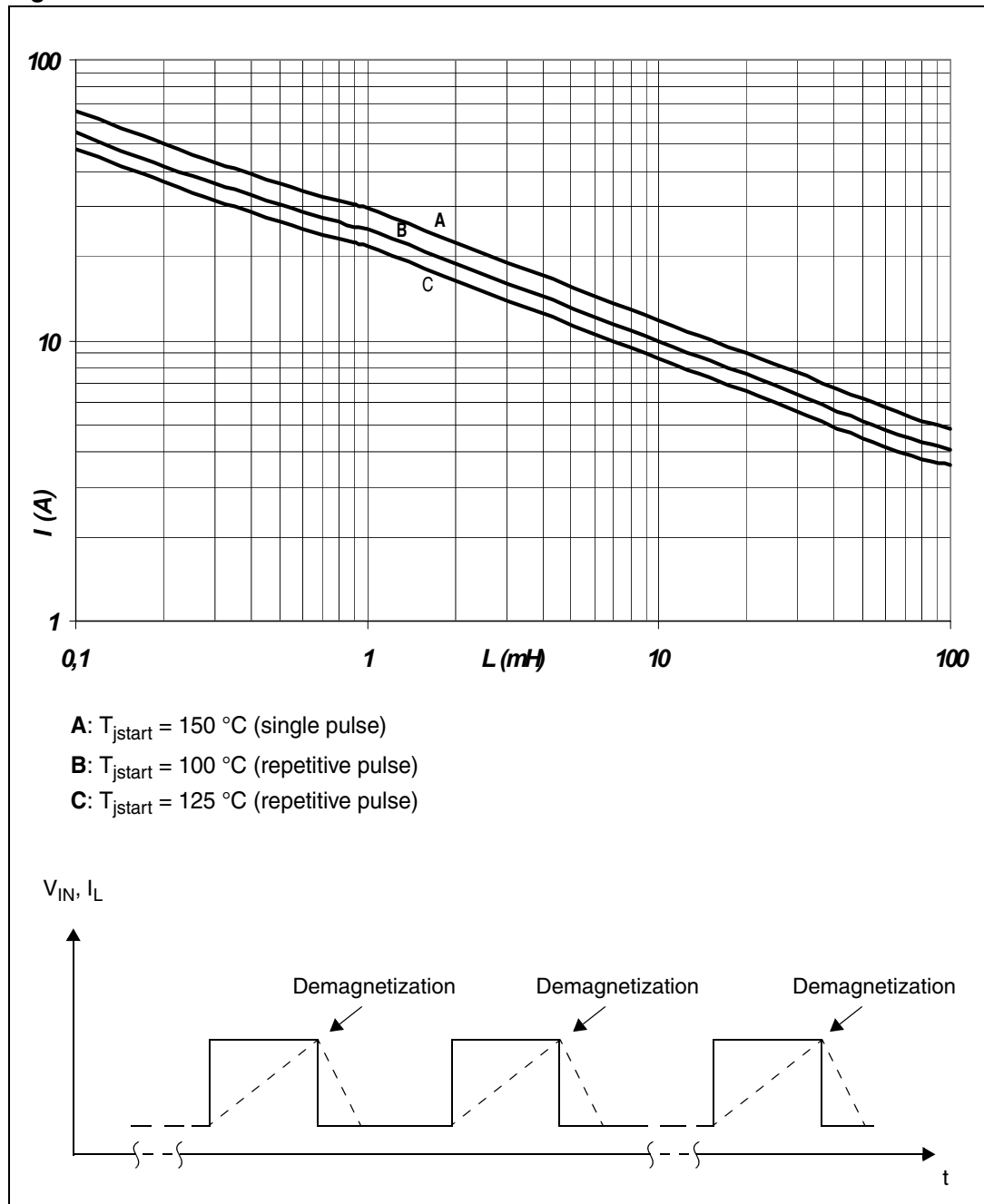

1. Values are generated with $R_L = 0\ \Omega$.

In case of repetitive pulses, T_{jstart} (at beginning of each demagnetization) of every pulse must not exceed the temperature specified above for curves A and B.

3 Package and PC board thermal data

3.1 HPAK thermal data

Figure 32. PC board⁽¹⁾

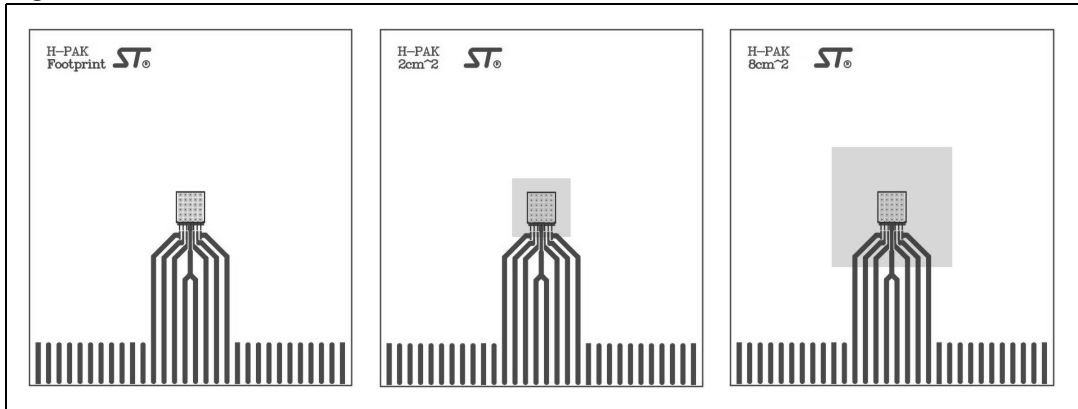

1. Layout condition of Rth and Zth measurements (PCB FR4 area = 58 mm x 58 mm, PCB thickness = 1.8 mm, Cu thickness = 70 μm, Copper areas: from minimum pad lay-out to 8 cm²).

Figure 33. R_{thj-amb} vs. PCB copper area in open box free air condition

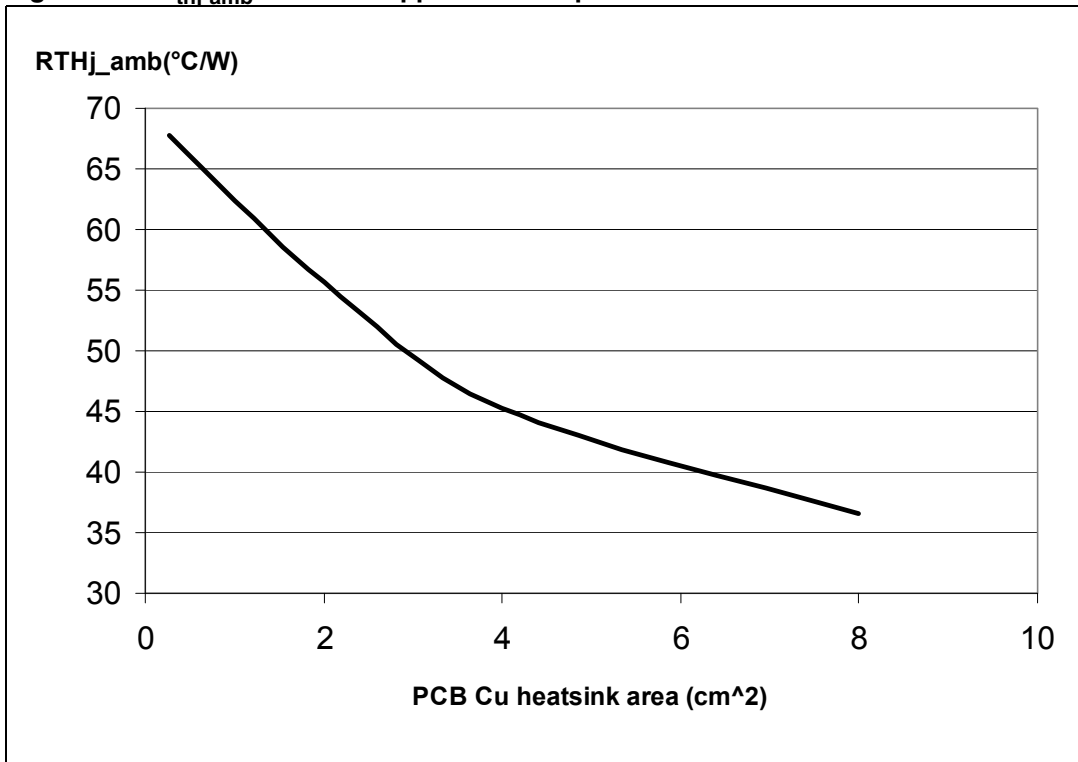

Figure 34. HPAK thermal impedance junction ambient single pulse

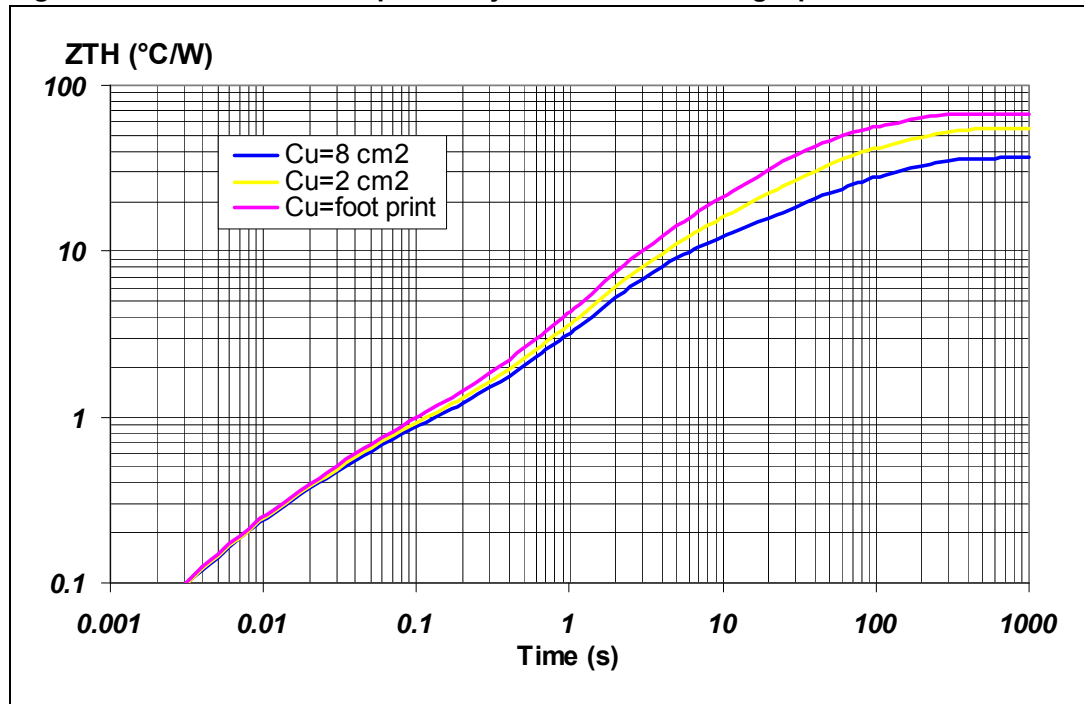
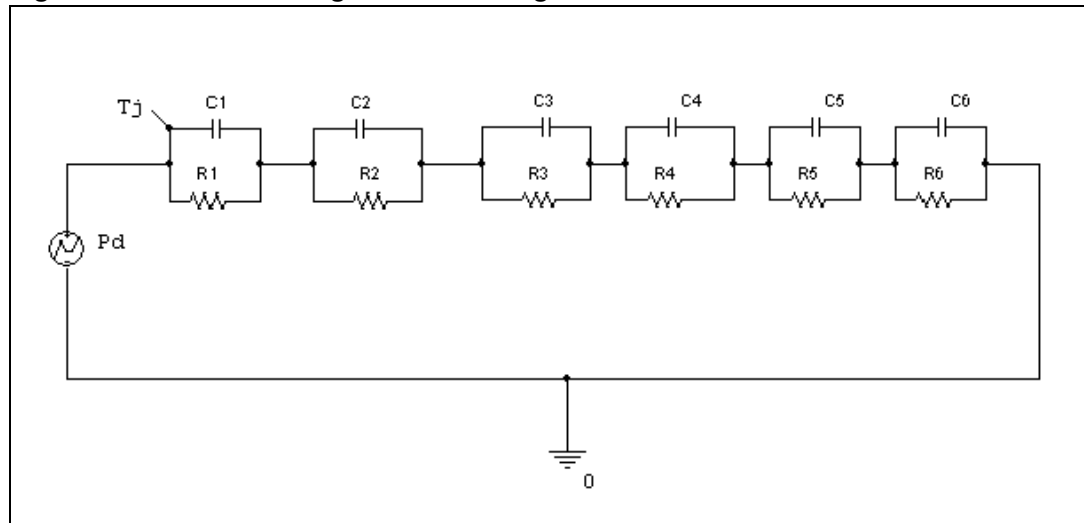

Figure 35. Thermal fitting model of a single-channel HSD in HPAK⁽¹⁾



1. The fitting model is a simplified thermal tool and is valid for transient evolutions where the embedded protections (power limitation or thermal cycling during thermal shutdown) are not triggered.

Equation 2: pulse calculation formula

$$Z_{TH\delta} = R_{TH} \cdot \delta + Z_{THtp}(1 - \delta)$$

where $\delta = t_p/T$

Table 14. Thermal parameter

Area/island (cm ²)	Footprint	4	8
R1 (°C/W)	0.01		
R2 (°C/W)	0.15		
R3 (°C/W)	0.5		
R4 (°C/W)	8		
R5 (°C/W)	28	22	12
R6 (°C/W)	31	25	16
C1 (W.s/°C)	0.005		
C2 (W.s/°C)	0.05		
C3 (W.s/°C)	0.1		
C4 (W.s/°C)	0.4		
C5 (W.s/°C)	0.8	1.4	3
C6 (W.s/°C)	3	6	9

4 Package and packing information

4.1 ECOPACK®

In order to meet environmental requirements, ST offers these devices in different grades of ECOPACK® packages, depending on their level of environmental compliance. ECOPACK® specifications, grade definitions and product status are available at: www.st.com. ECOPACK® is an ST trademark.

4.2 HPAK mechanical data

Figure 36. HPAK package dimension

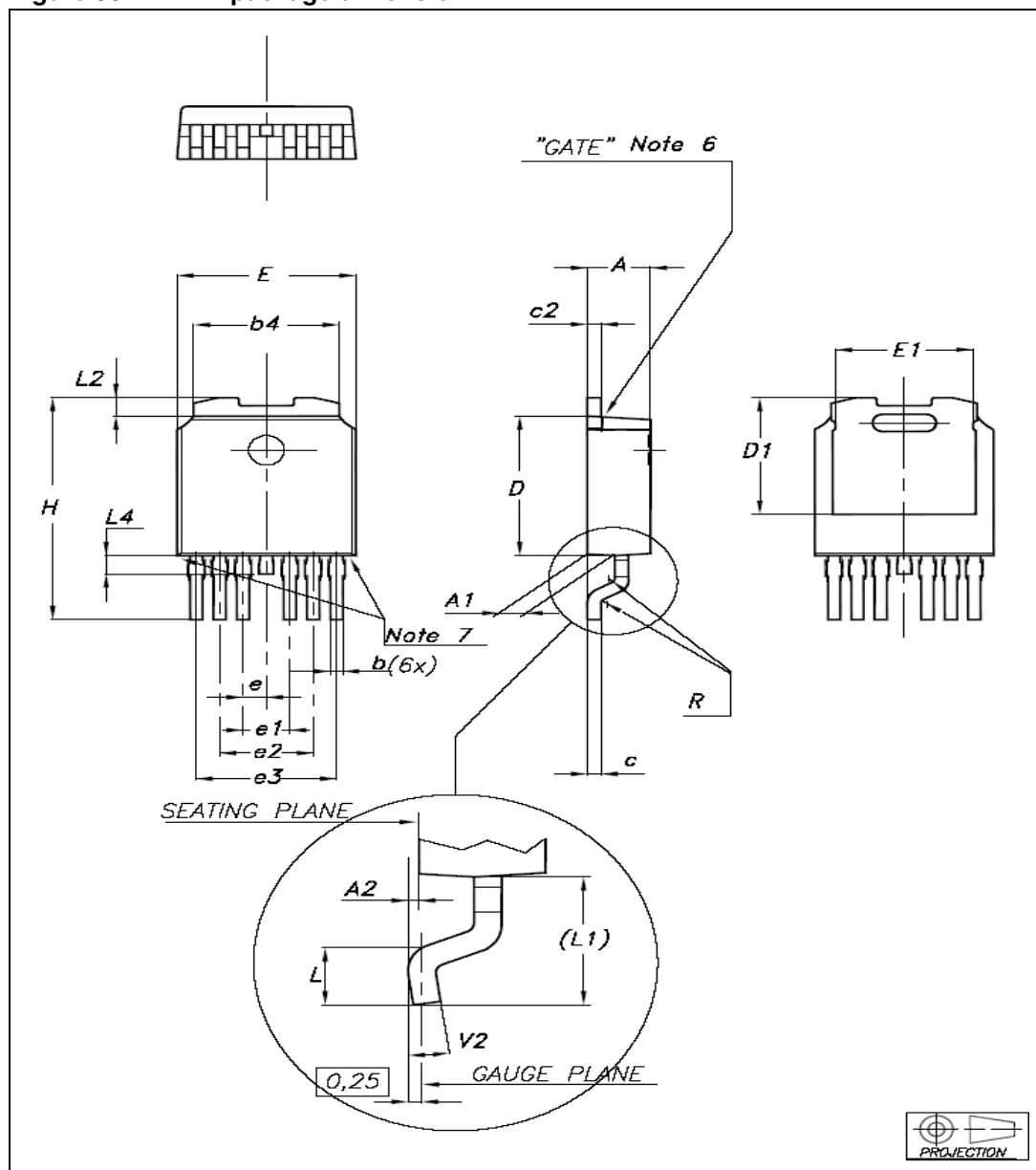
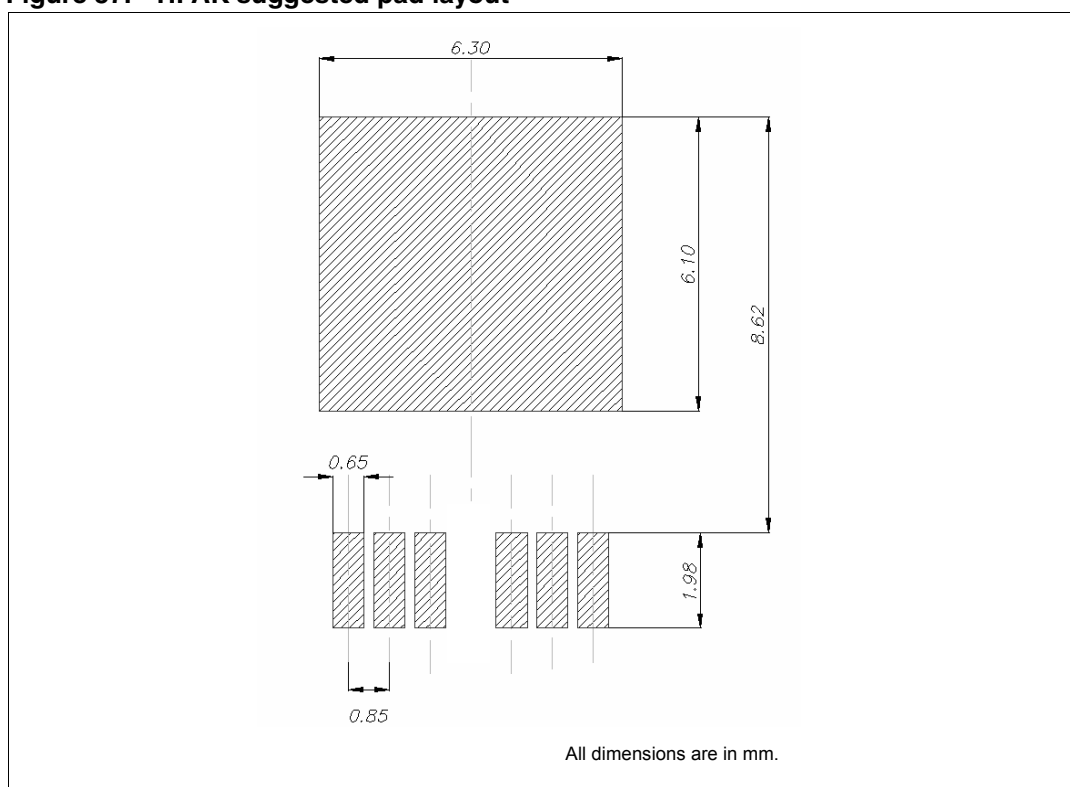

Table 15. HPAK mechanical data

Ref. dim	Data book mm		
	Nom.	Min.	Max.
A		2.20	2.40
A1		0.90	1.10
A2		0.03	0.23
b		0.45	0.60
b4		5.20	5.40
c		0.45	0.60
c2		0.48	0.60
D		6.00	6.20
D1	5.10		
E		6.40	6.60
E1	5.20		
e	0.85		
e1		1.60	1.80
e2		3.30	3.50
e3		5.00	5.20
H		9.35	10.10
L		1	
(L1)	2.80		
L2	0.80		
L4		0.60	1.00
R	0.20		
V2		0°	8°

4.3 HPAK suggested land pattern

Figure 37. HPAK suggested pad layout⁽¹⁾



1. The land pattern proposed is not intended to overrule User's PCB design, manufacturing and soldering process rules

4.4 Packing information

The devices can be packed in tube or tape and reel shipments (see [Table 16: Device summary](#)).

Figure 38. HPAK tube shipment (no suffix)

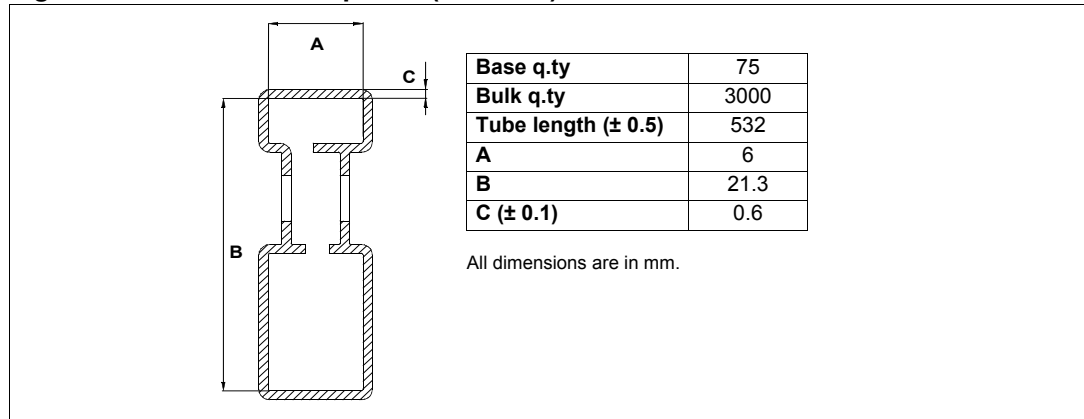
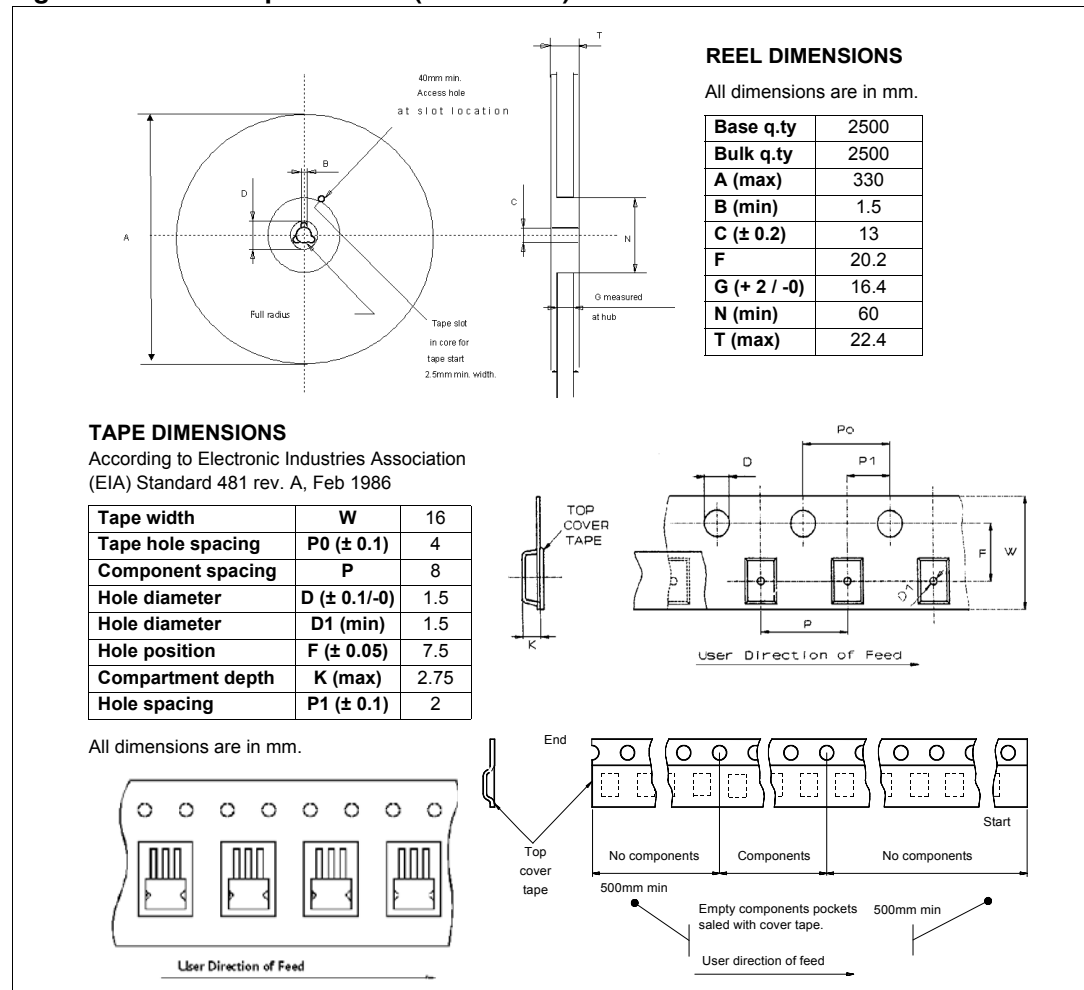

Figure 39. HPAK tape and reel (suffix “TR”)



5 Order codes

Table 16. Device summary

Package	Order codes	
	Tube	Tape and reel
6 pins HPAK	VN5E010MH-E	VN5E010MHTR-E

6 Revision history

Table 17. Document revision history

Date	Revision	Changes
28-May-2009	1	Initial release.
18-Jun-2009	2	<i>Figure 32: PC board⁽¹⁾</i> – Changed footnote
15-Dec-2009	3	Updated <i>Table 7: Logic inputs</i>
25-Jan-2010	4	Updated <i>Table 9: Current sense (8 V < V_{CC} < 18 V)</i>
27-May-2010	5	Updated <i>Table 15: HPAK mechanical data.</i>
18-Sep-2013	6	Updated Disclaimer.

Please Read Carefully:

Information in this document is provided solely in connection with ST products. STMicroelectronics NV and its subsidiaries ("ST") reserve the right to make changes, corrections, modifications or improvements, to this document, and the products and services described herein at any time, without notice.

All ST products are sold pursuant to ST's terms and conditions of sale.

Purchasers are solely responsible for the choice, selection and use of the ST products and services described herein, and ST assumes no liability whatsoever relating to the choice, selection or use of the ST products and services described herein.

No license, express or implied, by estoppel or otherwise, to any intellectual property rights is granted under this document. If any part of this document refers to any third party products or services it shall not be deemed a license grant by ST for the use of such third party products or services, or any intellectual property contained therein or considered as a warranty covering the use in any manner whatsoever of such third party products or services or any intellectual property contained therein.

UNLESS OTHERWISE SET FORTH IN ST'S TERMS AND CONDITIONS OF SALE ST DISCLAIMS ANY EXPRESS OR IMPLIED WARRANTY WITH RESPECT TO THE USE AND/OR SALE OF ST PRODUCTS INCLUDING WITHOUT LIMITATION IMPLIED WARRANTIES OF MERCHANTABILITY, FITNESS FOR A PARTICULAR PURPOSE (AND THEIR EQUIVALENTS UNDER THE LAWS OF ANY JURISDICTION), OR INFRINGEMENT OF ANY PATENT, COPYRIGHT OR OTHER INTELLECTUAL PROPERTY RIGHT.

ST PRODUCTS ARE NOT DESIGNED OR AUTHORIZED FOR USE IN: (A) SAFETY CRITICAL APPLICATIONS SUCH AS LIFE SUPPORTING, ACTIVE IMPLANTED DEVICES OR SYSTEMS WITH PRODUCT FUNCTIONAL SAFETY REQUIREMENTS; (B) AERONAUTIC APPLICATIONS; (C) AUTOMOTIVE APPLICATIONS OR ENVIRONMENTS, AND/OR (D) AEROSPACE APPLICATIONS OR ENVIRONMENTS. WHERE ST PRODUCTS ARE NOT DESIGNED FOR SUCH USE, THE PURCHASER SHALL USE PRODUCTS AT PURCHASER'S SOLE RISK, EVEN IF ST HAS BEEN INFORMED IN WRITING OF SUCH USAGE, UNLESS A PRODUCT IS EXPRESSLY DESIGNATED BY ST AS BEING INTENDED FOR "AUTOMOTIVE, AUTOMOTIVE SAFETY OR MEDICAL" INDUSTRY DOMAINS ACCORDING TO ST PRODUCT DESIGN SPECIFICATIONS. PRODUCTS FORMALLY ESCC, QML OR JAN QUALIFIED ARE DEEMED SUITABLE FOR USE IN AEROSPACE BY THE CORRESPONDING GOVERNMENTAL AGENCY.

Resale of ST products with provisions different from the statements and/or technical features set forth in this document shall immediately void any warranty granted by ST for the ST product or service described herein and shall not create or extend in any manner whatsoever, any liability of ST.

ST and the ST logo are trademarks or registered trademarks of ST in various countries.

Information in this document supersedes and replaces all information previously supplied.

The ST logo is a registered trademark of STMicroelectronics. All other names are the property of their respective owners.

© 2013 STMicroelectronics - All rights reserved



STMicroelectronics group of companies

Australia - Belgium - Brazil - Canada - China - Czech Republic - Finland - France - Germany - Hong Kong - India - Israel - Italy - Japan - Malaysia - Malta - Morocco - Philippines - Singapore - Spain - Sweden - Switzerland - United Kingdom - United States of America







www.st.com

Looking for pricing, stock, or lifecycle information?

Click below to explore more details on WIN SOURCE:

-  [View VN5E010MHTR-E on WIN SOURCE](#)
-  [STMicroelectronics](#) Information

Optimize Your Supply Chain with WIN SOURCE Solutions

-  Global Sourcing Solution
-  Obsolete Management
-  Cost Control Management
-  Shortage Management
-  Alternative Solution
-  Excess Inventory Management