

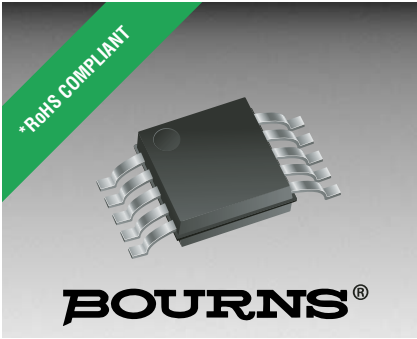

**THE DATASHEET OF
CDMSP10-0504M**





Features

- RoHS compliant*
- Protects four I/O lines
- Ultra-low capacitance ~ 0.55 pF
- ESD protection >30 kV
- Surge protection

Applications

- High Definition Multimedia Interface (HDMI)
- Digital Visual Interface (DVI)
- Ethernet 10/100/1000 Mb/s
- SATA interface
- Portable electronics

CDMSP10-0504M – Surface Mount TVS Diode Array

General Information

The CDMSP10-0504M device provides ESD, EFT and Surge protection for high speed data ports meeting IEC 61000-4-2 (ESD), IEC 61000-4-4 (EFT) and IEC 61000-4-5 (Surge) requirements. The Transient Voltage Suppressor array, protecting up to 4 data lines, offers a Working Peak Reverse Voltage of 5 V and Minimum Breakdown Voltage of 6 V.

The MSOP-10L packaged device will mount directly onto the industry standard MSOP-10L footprint. Bourns® Chip Diodes conform to JEDEC standards, are easy to handle with standard pick and place equipment and their flat configuration minimizes roll away.

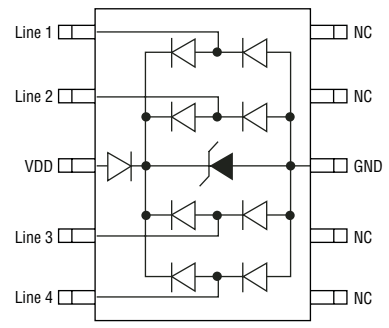

Absolute Maximum Ratings (@ T_A = 25 °C Unless Otherwise Noted)

Parameter	Symbol	Value	Unit
Operating Supply Voltage	V _{DC}	6	V
DC Voltage at any I/O Pin	V _D	(Gnd - 0.5) to (Vdd + 0.5)	V
ESD Performance per IEC 61000-4-2 (I/O Pins)	Air Discharge	V _{ESD} I/O	19 kV
	Contact Discharge	V _{ESD} I/O	12 kV
ESD Performance per IEC 61000-4-2 (VDD, GND Pins)	Air Discharge	V _{ESD} PW	30 kV
	Contact Discharge	V _{ESD} PW	30 kV
Storage Temperature	T _{STG}	-55 °C to +150 °C	°C
Operating Temperature	T _{OPR}	-55 °C to +150 °C	°C

How To Order

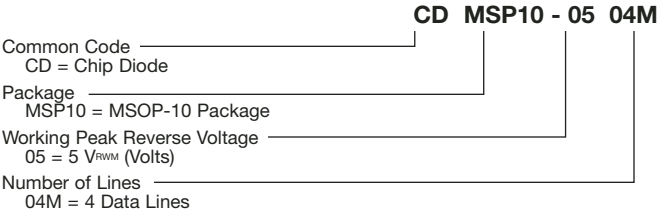

Typical Part Marking

CDMSP10-0504MB0504

Schematic

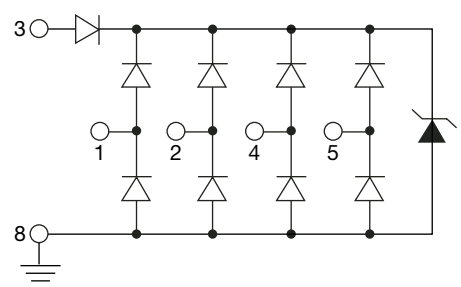

*RoHS Directive 2002/95/EC Jan 27 2003 including Annex Specifications are subject to change without notice. Customers should verify actual device performance in their specific applications.

CDMSP10-0504M – Surface Mount TVS Diode Array

BOURNS®

Electrical Characteristics (@ T_A = 25 °C Unless Otherwise Noted)

Parameter	Symbol	Minimum	Nominal	Maximum	Unit
Reverse Standoff Voltage ¹	V _{RWM}			5	V
Leakage Current ¹ @ V _{RWM}	I _D			5	μA
Channel Leakage Current @ V _{RWM}	I _{CD}			1	μA
Reverse Breakdown Voltage @ V _{RWM}	V _{BR}	6		9	V
Forward Voltage ³ @ I _F = 15 mA	V _F		0.8	1	V
ESD Clamping Voltage ² @ IEC 61000-4-2 +6 kV, Contact Mode	V _C		12.5		V
ESD Clamping Voltage ¹ @ IEC 61000-4-2 +6 kV, Contact Mode	V _C		9.5		V
ESD Dynamic Turn-On Resistance - I/O ²	R _{dyn_io}		0.33		Ohms
ESD Dynamic Turn-On Resistance - V _{DD} ¹	R _{dyn_VDD}		0.16		Ohms
Channel Input Capacitance ² - 1 @ V _{PIN3} =5 V, V _{IN} =2.5 V, f = 1 MHz	C _{IN-1}		0.55	0.65	pF
Channel Input Capacitance ² - 2 @ V _{PIN3} =N/C, V _{IN} =2.5 V, f = 1 MHz	C _{IN-2}		0.70	0.80	pF
Channel to Channel Input Capacitance - 1 @ V _{PIN3} =5 V, V _{IN} =2.5 V, f = 1 MHz (Between channel pins)	C _{CROSS-1}		0.08	0.09	pF
Channel to Channel Input Capacitance - 2 @ V _{PIN3} =N/C, V _{IN} =2.5 V, f = 1 MHz (Between channel pins)	C _{CROSS-2}		0.10	0.11	pF
Variation of Channel Input Capacitance - 1 @ V _{PIN3} =5 V, V _{IN} =2.5 V, f = 1 MHz (Channel x Pin to GND, Channel y Pin to GND)	ΔC _{IN-1}		0.04	0.06	pF
Variation of Channel Input Capacitance - 2 @ V _{PIN3} =N/C, V _{IN} =2.5 V, f = 1 MHz (Channel x Pin to GND, Channel y Pin to GND)	ΔC _{IN-2}		0.05	0.08	pF

Notes:

1. Test from V_{dd} Pin 3 to Gnd Pin 8
2. Test from Pin 1,2,4 or 5 to Gnd Pin 8
3. Test from Gnd Pin 8 to V_{dd} Pin 3

CDMSP10-0504M – Surface Mount TVS Diode Array



Product Dimensions

This is a molded JEDEC MSOP-10L package with lead free 100 % Matte Sn on the lead frame. It weighs approximately 7 mg and has a flammability rating of UL 94V-0.

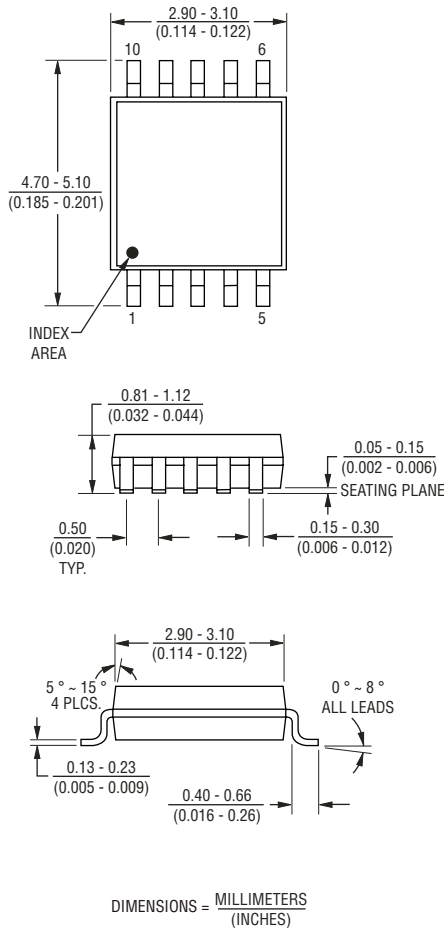

Recommended Footprint

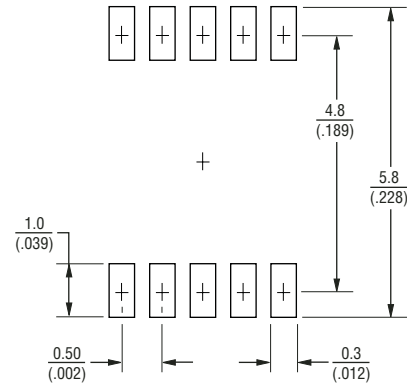

This LAND LAYOUT is for reference purposes only. Please consult your manufacturing partners to ensure your company's PCB design guidelines are met.

Typical Application

This ESD protection device is ideal in high speed data port protection such as HDMI where capacitance per line is critical parameter. See example connection below.

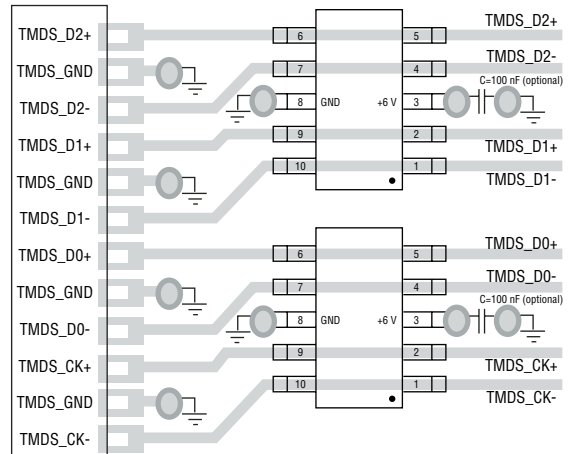

CDMSP10-0504M – Surface Mount TVS Diode Array



Characteristic Curves

Insertion Loss S21 (I/O-to-GND)

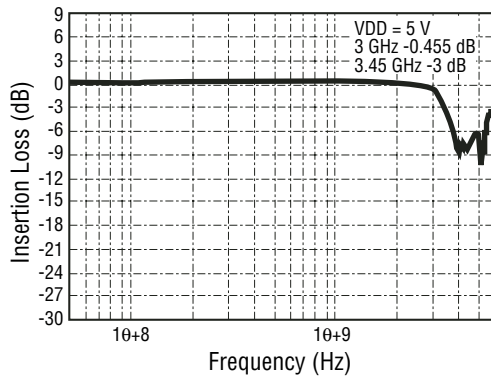

Insertion Loss S21 (I/O-to-GND)

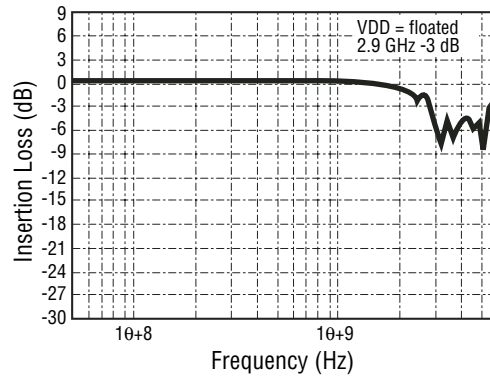

Analog Cross Talk

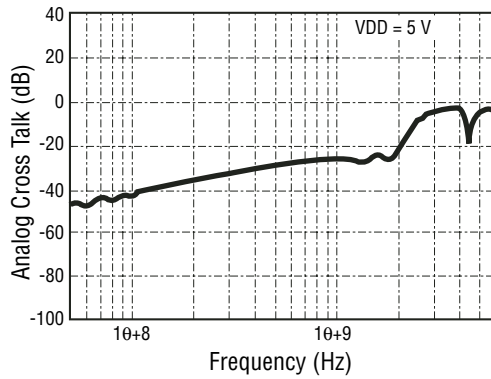

Analog Cross Talk

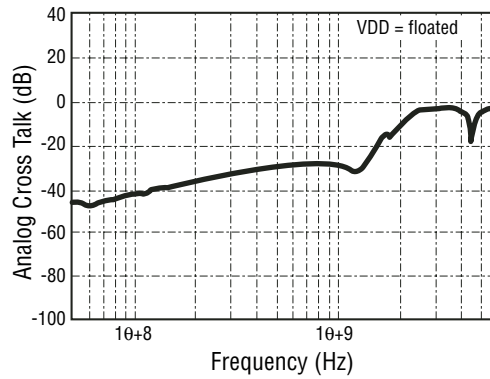

Transmission Line Pulsing (TLP) Measurement

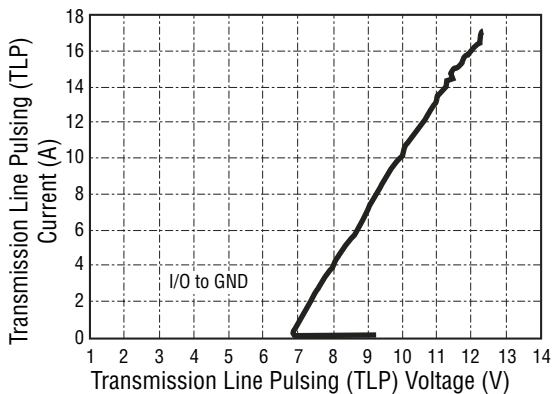

Transmission Line Pulsing (TLP) Measurement

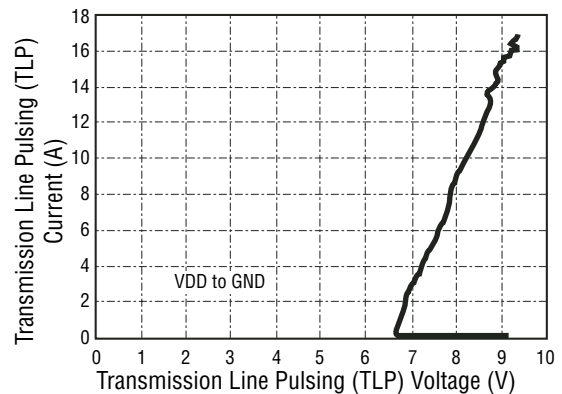

Characteristic Curves

Typical Variation of C_{IN} vs. V_{IN}

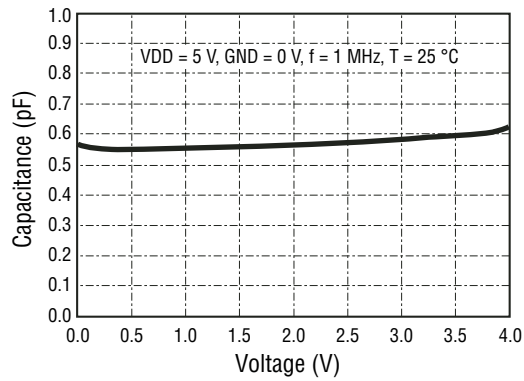

Typical Variation of C_{IN} vs. V_{IN}

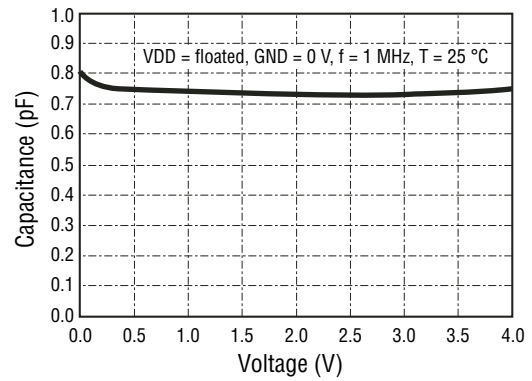

Typical Variation of $C_{IO-to-IO}$ vs. V_{IN}

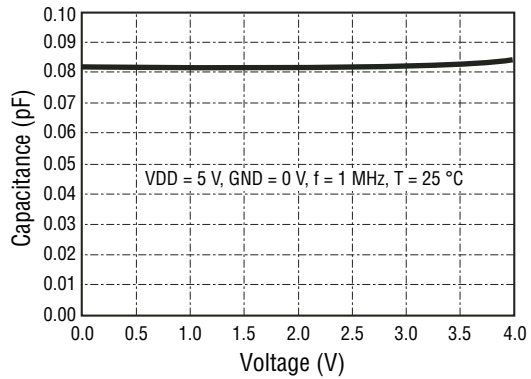

Typical Variation of $C_{IO-to-IO}$ vs. V_{IN}

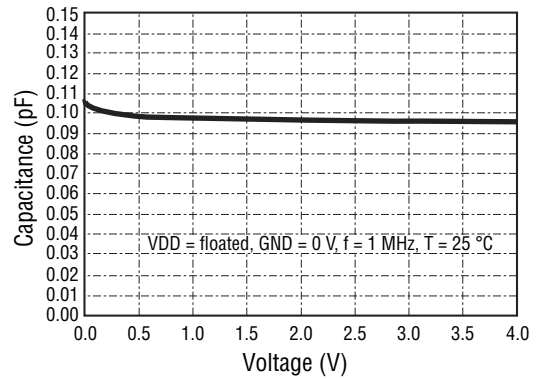

CDMSP10-0504M – Surface Mount TVS Diode Array

BOURNS®

Packaging Information

The product will be dispensed in tape and reel format (see diagram below).

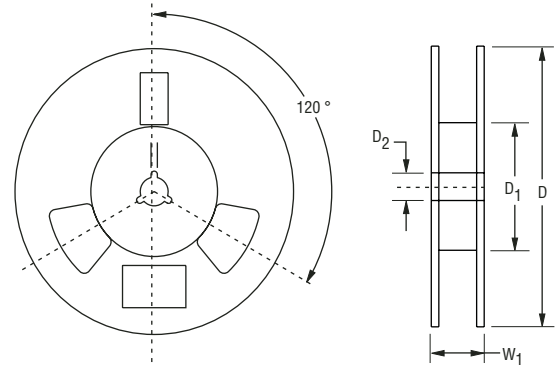
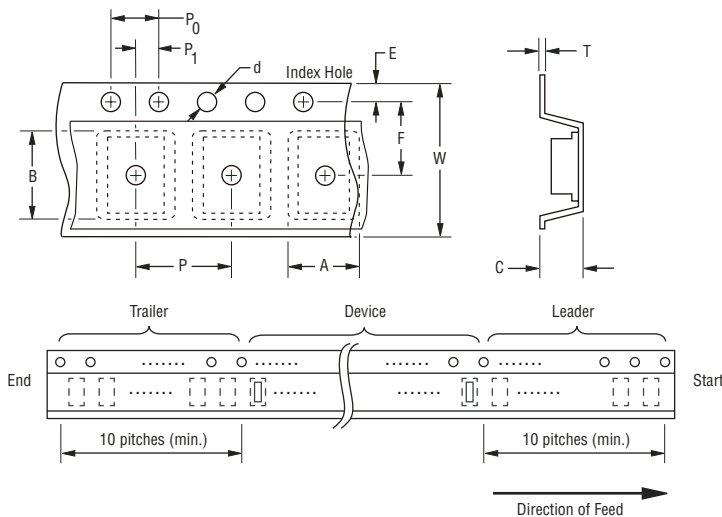

Devices are packed in accordance with EIA standard RS-481-A.

DIMENSIONS: $\frac{\text{MM}}{\text{(INCHES)}}$

Item	Symbol	MSOP-10L
Carrier Width	A	$\frac{5.5 \pm 0.10}{(0.216 \pm 0.004)}$
Carrier Length	B	$\frac{3.5 \pm 0.10}{(0.138 \pm 0.004)}$
Carrier Depth	C	$\frac{1.5 \pm 0.10}{(0.059 \pm 0.004)}$
Sprocket Hole	d	$\frac{1.55 \pm 0.05}{(0.061 \pm 0.002)}$
Reel Outside Diameter	D	$\frac{178}{(7.008)}$
Reel Inner Diameter	D ₁	$\frac{50.0}{(1.969)}$ MIN.
Feed Hole Diameter	D ₂	$\frac{13.0 \pm 0.20}{(0.512 \pm 0.008)}$
Sprocket Hole Position	E	$\frac{1.75 \pm 0.10}{(0.069 \pm 0.004)}$
Punch Hole Position	F	$\frac{3.50 \pm 0.05}{(0.138 \pm 0.002)}$
Punch Hole Pitch	P	$\frac{8.00 \pm 0.10}{(0.314 \pm 0.004)}$
Sprocket Hole Pitch	P ₀	$\frac{4.00 \pm 0.10}{(0.157 \pm 0.004)}$
Embossment Center	P ₁	$\frac{2.00 \pm 0.05}{(0.079 \pm 0.002)}$
Overall Tape Thickness	T	$\frac{0.20 \pm 0.10}{(0.008 \pm 0.004)}$
Tape Width	W	$\frac{12.0 \pm 0.20}{(0.470 \pm 0.008)}$
Reel Width	W ₁	$\frac{14.4}{(0.567)}$
Quantity per Reel	--	3000





Asia-Pacific:
Tel: +886-2 2562-4117 • Fax: +886-2 2562-4116
Europe:
Tel: +41-41 768 5555 • Fax: +41-41 768 5510
The Americas:
Tel: +1-951 781-5500 • Fax: +1-951 781-5700
www.bourns.com

09/08

Specifications are subject to change without notice. Customers should verify actual device performance in their specific applications.

Looking for pricing, stock, or lifecycle information?

Click below to explore more details on WIN SOURCE:

-  [View CDMSP10-0504M on WIN SOURCE](#)
-  [Bourns Inc. Information](#)

Optimize Your Supply Chain with WIN SOURCE Solutions

-  Global Sourcing Solution
-  Obsolete Management
-  Cost Control Management
-  Shortage Management
-  Alternative Solution
-  Excess Inventory Management