

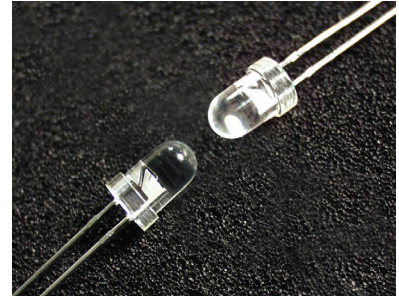

**THE DATASHEET OF  
C503B-AAS-CY0B0251**



# Cree® 5-mm Red and Amber Round LED C503C-RCS/RCN/ACS/ACN



## PRODUCT DESCRIPTION

Round LEDs offer superior light output for excellent readability in sunlight and dependable performance. They provide extremely stable light output over long periods of time.

These lamps are made with an advanced optical-grade epoxy offering superior high-temperature and high-moisture-resistance performance in outdoor signal and sign applications.

## FEATURES

- Size (mm): 5
- Color and Typical Dominant Wavelength:  
Red (624nm)  
Amber(591nm)
- Luminous Intensity (mcd)  
C503C-RCS/RCN:(5860 - 10100)  
C503C-ACS/ACN:(5860 - 10100)
- Viewing angle:  
C503C-RCS/RCN/ACS/ACN:  
30 degree
- Lead - Free
- RoHS Compliant

## APPLICATIONS

- Electronic Signs & Signals (ESS)
- Motorway Signs
- Variable Message Sign (VMS)
- Advertising signs
- Petrol Signs
- Amusement

## ABSOLUTE MAXIMUM RATINGS ( $T_A = 25^\circ\text{C}$ )

Items	Symbol	Absolute Maximum Rating	Unit
		Red/Amber	
Forward Current	$I_F$	50 <sup>Note1</sup>	mA
Peak Forward Current <sup>Note2</sup>	$I_{FP}$	200	mA
Reverse Voltage	$V_R$	5	V
Power Dissipation	$P_D$	130	mW
Operation Temperature	$T_{opr}$	-40 ~ +100	$^\circ\text{C}$
Storage Temperature	$T_{stg}$	-40 ~ +100	$^\circ\text{C}$
Lead Soldering Temperature	$T_{sol}$	Max. 260 $^\circ\text{C}$ for 3 sec. max. (3 mm from the base of the epoxy bulb)	
Electrostatic Discharge Classification (MIL-STD-883E)	ESD	Class 2	

### Note:

- For long term performance the drive currents between 10mA and 30mA are recommended. Please contact CREE sales representative for more information on recommended drive conditions.
- Pulse width  $\leq 0.1$  msec, duty  $\leq 1/10$ .

## TYPICAL ELECTRICAL & OPTICAL CHARACTERISTICS ( $T_A = 25^\circ\text{C}$ )

Characteristics	Color	Symbol	Condition	Unit	Minimum	Typical	Maximum
Forward Voltage	Red/Amber	$V_F$	$I_F = 20$ mA	V		2.1	2.6
Reverse Current	Red/Amber	$I_R$	$V_R = 5$ V	$\mu\text{A}$			100
Dominant Wavelength	Red	$\lambda_D$	$I_F = 20$ mA	nm	618	624	630
	Amber	$\lambda_D$	$I_F = 20$ mA	nm	584	591	596
Luminous Intensity	Red	C503C-RCS/RCN	$I_V$	$I_F = 20$ mA	mcd	5860	7400
	Amber	C503C-ACS/ACN	$I_V$	$I_F = 20$ mA	mcd	5860	7600
50% Power Angle	C503C-RCS/RCN/ACS/ACN	$2\theta_{1/2}$	$I_F = 20$ mA	deg		30	

**Note:** Continuous reverse voltage can cause LED damage.

## INTENSITY BIN LIMIT ( $I_f = 20 \text{ mA}$ )

Red  
C503C-RCS/RCN

Bin Code	Min. (mcd)	Max. (mcd)	Bin Code	Min. (mcd)	Max. (mcd)	Bin Code	Min. (mcd)	Max. (mcd)	
Y	Y0	5860	8200	Ya	5860	7030	YA	5860	6500
				Yb	7030	8200	YB	6500	7200
Z	Z0	8200	12000	Za	8200	10100			

Amber

C503C-ACS/ACN

Bin Code	Min. (mcd)	Max. (mcd)	Bin Code	Min. (mcd)	Max. (mcd)	Bin Code	Min. (mcd)	Max. (mcd)	
Y	Y0	5860	8200	Ya	5860	7030	YA	5860	6500
				Yb	7030	8200	YB	6500	7200
Z	Z0	8200	12000	Za	8200	10100			

- Tolerance of measurement of luminous intensity is  $\pm 15\%$

## COLOR BIN LIMIT ( $I_f = 20 \text{ mA}$ )

Red

Bin Code	Min. (nm)	Max. (nm)
RA	618	630

Amber

Bin Code	Min. (nm)	Max. (nm)
A2	584	587
A3	587	590
A4	590	593
A5	593	596

- Tolerance of measurement of dominant wavelength is  $\pm 1 \text{ nm}$

**ORDER CODE TABLE\***

Red

Color	Kit Number	Viewing Angle	Luminous Intensity (mcd)		Dominant Wavelength				Package	Standoff
			Min.	Max.	Color Bin	Min. (nm)	Color Bin	Max. (nm)		
Red	C503C-RCS-CYAZaAA1	30	5860	10100	RA	618	RA	630	Bulk	Yes
Red	C503C-RCS-CYBYCAA1	30	6500	8200	RA	618	RA	630	Bulk	Yes
Red	C503C-RCS-CYCZaAA1	30	7200	10100	RA	618	RA	630	Bulk	Yes
Red	C503C-RCS-CYAZaAA2	30	5860	10100	RA	618	RA	630	Ammo	Yes
Red	C503C-RCS-CYBYCAA2	30	6500	8200	RA	618	RA	630	Ammo	Yes
Red	C503C-RCS-CYCZaAA2	30	7200	10100	RA	618	RA	630	Ammo	Yes
Red	C503C-RCN-CYAZaAA1	30	5860	10100	RA	618	RA	630	Bulk	No
Red	C503C-RCN-CYBYCAA1	30	6500	8200	RA	618	RA	630	Bulk	No
Red	C503C-RCN-CYCZaAA1	30	7200	10100	RA	618	RA	630	Bulk	No
Red	C503C-RCN-CYAZaAA2	30	5860	10100	RA	618	RA	630	Ammo	No
Red	C503C-RCN-CYBYCAA2	30	6500	8200	RA	618	RA	630	Ammo	No
Red	C503C-RCN-CYCZaAA2	30	7200	10100	RA	618	RA	630	Ammo	No

**ORDER CODE TABLE\***

Amber

Color	Kit Number	Viewing Angle	Luminous Intensity (mcd)		Dominant Wavelength				Package	Standoff
			Min.	Max.	Color Bin	Min. (nm)	Color Bin	Max. (nm)		
Amber	C503C-ACS-CYAza251	30	5860	10100	A2	584	A5	596	Bulk	Yes
Amber	C503C-ACS-CYAza341	30	5860	10100	A3	587	A4	593	Bulk	Yes
Amber	C503C-ACS-CYCza251	30	7200	10100	A2	584	A5	596	Bulk	Yes
Amber	C503C-ACS-CYCza341	30	7200	10100	A3	587	A4	593	Bulk	Yes
Amber	C503C-ACS-CYAza252	30	5860	10100	A2	584	A5	596	Ammo	Yes
Amber	C503C-ACS-CYAza342	30	5860	10100	A3	587	A4	593	Ammo	Yes
Amber	C503C-ACS-CYCza252	30	7200	10100	A2	584	A5	596	Ammo	Yes
Amber	C503C-ACS-CYCza342	30	7200	10100	A3	587	A4	593	Ammo	Yes
Amber	C503C-ACN-CYAza251	30	5860	10100	A2	584	A5	596	Bulk	No
Amber	C503C-ACN-CYAza341	30	5860	10100	A3	587	A4	593	Bulk	No
Amber	C503C-ACN-CYCza251	30	7200	10100	A2	584	A5	596	Bulk	No
Amber	C503C-ACN-CYCza341	30	7200	10100	A3	587	A4	593	Bulk	No
Amber	C503C-ACN-CYAza252	30	5860	10100	A2	584	A5	596	Ammo	No
Amber	C503C-ACN-CYAza342	30	5860	10100	A3	587	A4	593	Ammo	No
Amber	C503C-ACN-CYCza252	30	7200	10100	A2	584	A5	596	Ammo	No
Amber	C503C-ACN-CYCza342	30	7200	10100	A3	587	A4	593	Ammo	No

Notes:

1. The above kit numbers represent order codes that include multiple intensity-bin and color-bin codes. Only one intensity-bin code and one color-bin code will be shipped on each bulk. Single intensity-bin code and single color-bin codes will not be orderable.
2. Please refer to the "Cree LED Lamp Reliability Test Standards" document #1 for reliability test conditions.
3. Please refer to the "Cree LED Lamp Soldering & Handling" document #2 for information about how to use this LED product safely.

#1: Refer to [http://www.cree.com/led-components/media/documents/LED\\_Lamp\\_Reliability\\_Test\\_Standard.pdf](http://www.cree.com/led-components/media/documents/LED_Lamp_Reliability_Test_Standard.pdf)

#2: Refer to <http://www.cree.com/led-components/media/documents/sh-HB.pdf>

## GRAPHS

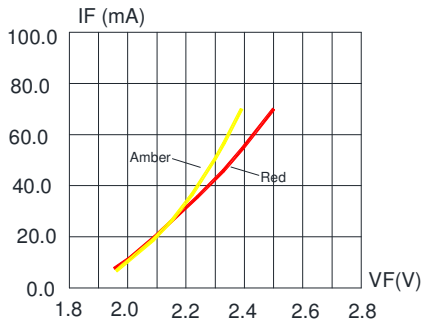

FIG.1 FORWARD CURRENT VS. FORWARD VOLTAGE.

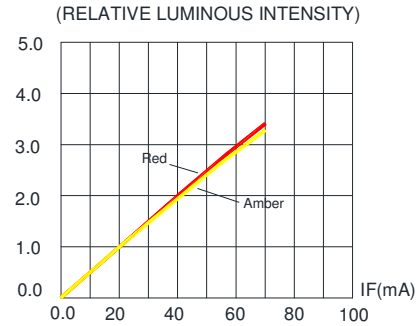

FIG.2 RELATIVE LUMINOUS INTENSITY VS. FORWARD CURRENT

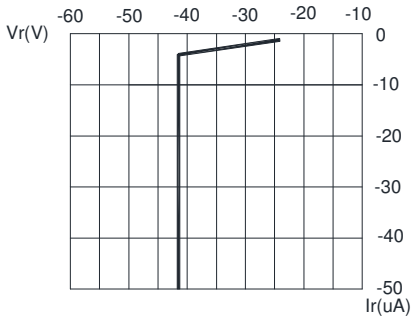

FIG.3 RED & AMBER REVERSE CURRENT VS. REVERSE VOLTAGE.

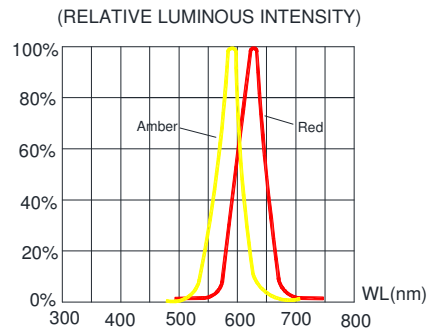

FIG.4 RELATIVE LUMINOUS INTENSITY VS. WAVELENGTH.

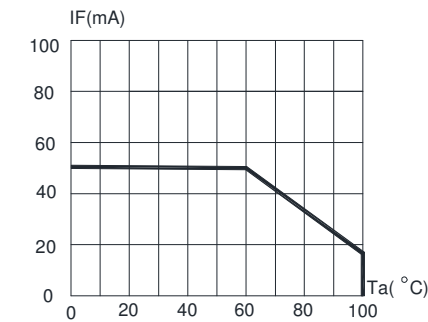

FIG.5 RED & AMBER MAXIMUM FORWARD DC CURRENT VS AMBIENT TEMPERATURE ( $T_{jmax}=110^{\circ}\text{C}$ )

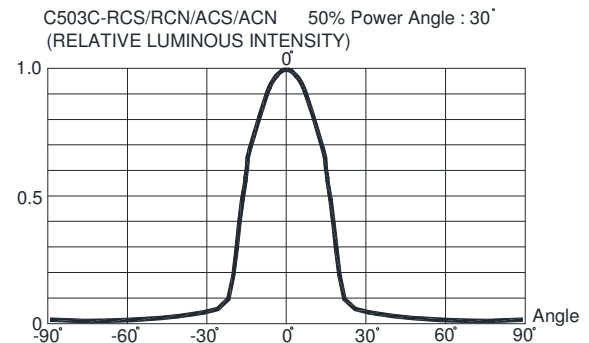

FIG.6 FAR FIELD PATTERN

The above data are collected from statistical figures that do not necessarily correspond to the actual parameters of each single LED. Hence, these data will be changed without further notice.

## MECHANICAL DIMENSIONS

All dimensions are in mm. Tolerance is  $\pm 0.25$  mm unless otherwise noted.

An epoxy meniscus may extend about 1.5 mm down the leads.

Burr around bottom of epoxy may be 0.5 mm max.

C503C-RCS:

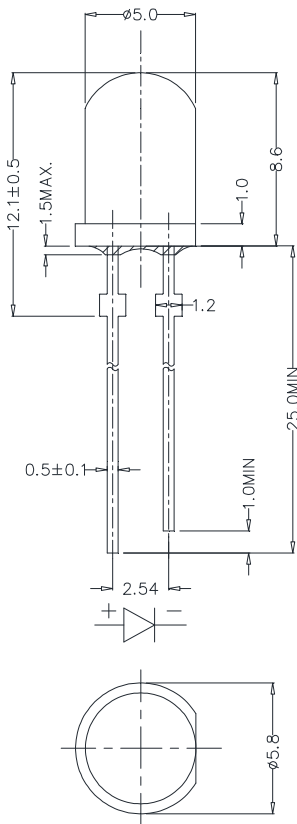

C503C-ACS:

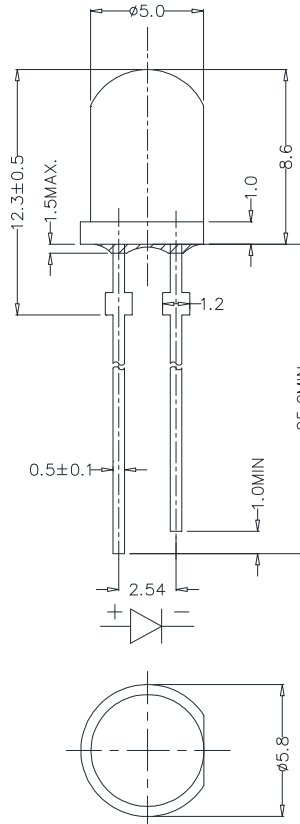

C503C-RCN/ACN:

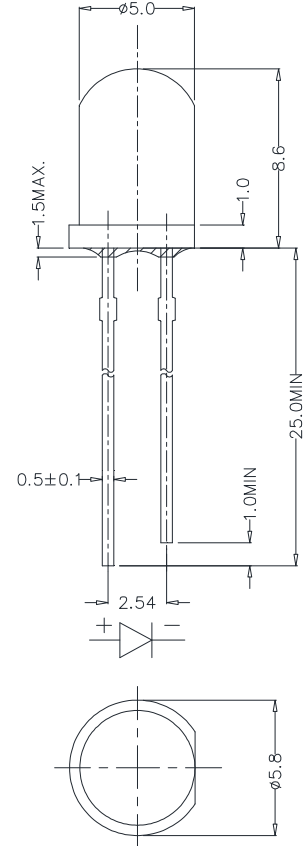

## NOTES

### RoHS Compliance

The levels of environmentally sensitive, persistent biologically toxic (PBT), persistent organic pollutants (POP), or otherwise restricted materials in this product are below the maximum concentration values (also referred to as the threshold limits) permitted for such substances, or are used in an exempted application, in accordance with EU Directive 2002/95/EC on the restriction of the use of certain hazardous substances in electrical and electronic equipment (RoHS), as amended through April 21, 2006.

### Vision Advisory Claim

Users should be cautioned not to stare at the light of this LED product. The bright light can damage the eye.

## KIT NUMBER SYSTEM

All dimensions in mm. Cree LED lamps are tested and sorted into performance bins. A bin is specified by ranges of color, forward voltage, and brightness. Sorted LEDs are packaged for shipping in various convenient options. Please refer to the "Cree LED Lamp Packaging Standard" document for more information about shipping and packaging options.

Cree LEDs are sold by order codes in combinations of bins called kits. Order codes are configured in the following manner:

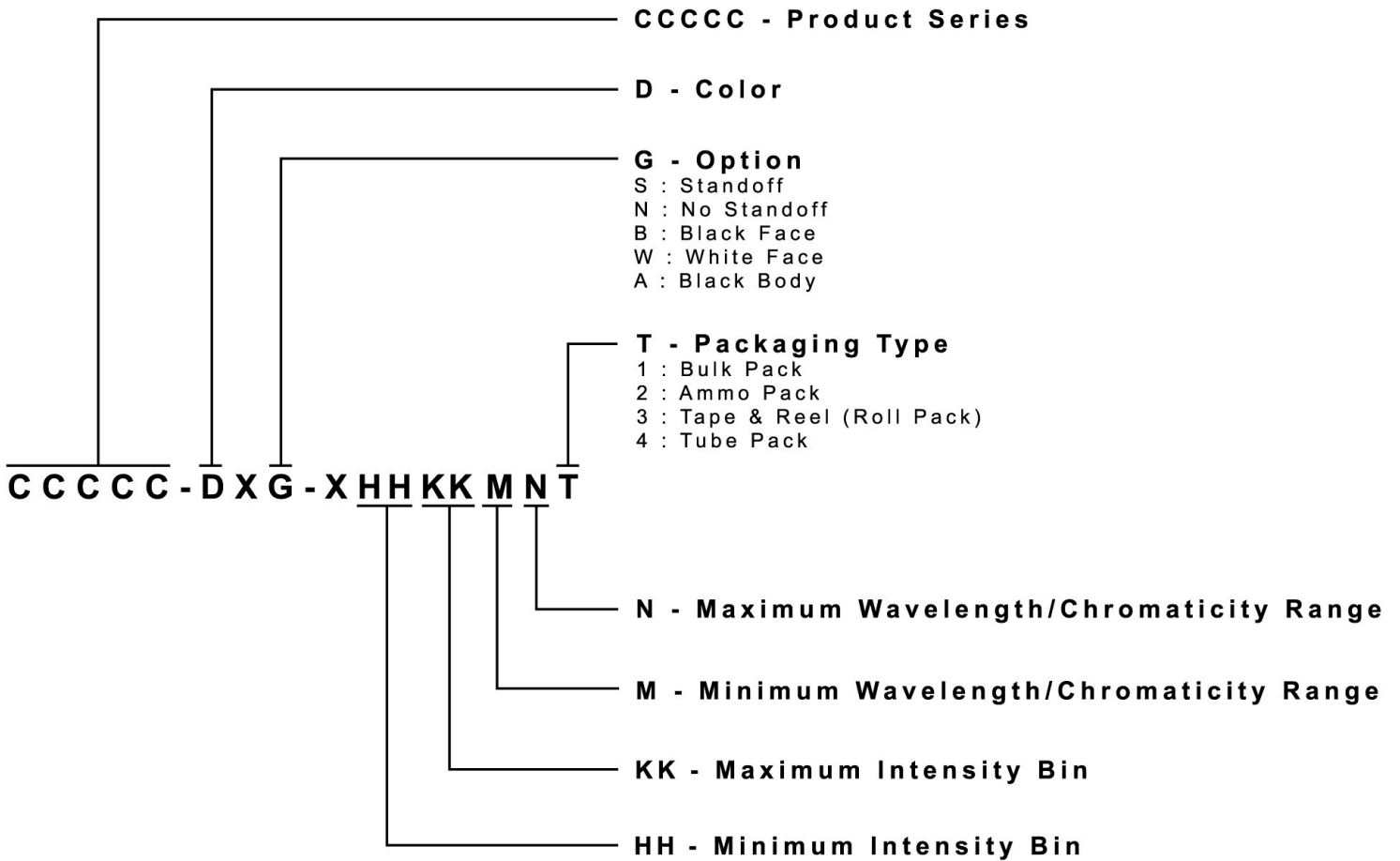

## REFLOW SOLDERING

The LED soldering specification is shown below (suitable for both leaded solder & lead-free solder):

Manual Soldering		Solder Dipping	
Soldering iron	35 W max	Preheat	110 °C max
Temperature	300 °C max	Preheat time	60 seconds max
		Solder-bath temperature	260 °C Max
Soldering time	3 seconds max	Dipping time	5 seconds max
Position	Not less than 3 mm from the base of the package.	Position	Not less than 3 mm from the base of the package.

- Manual soldering onto the PCB is not recommended because soldering time is uncontrollable.
- The recommended wave soldering is as below:

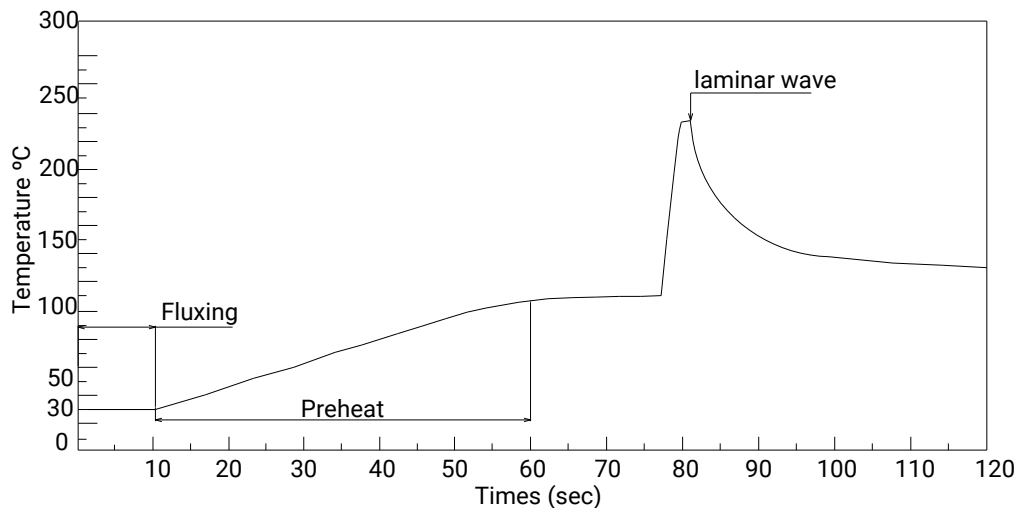

- Do not apply any stress to the LED package, particularly when heated.
- Only bottom preheat is suggested & should not preheat on top in order to reduce thermal stress experienced by the LEDs.
- The LEDs must not be re used once they have been extracted from PCB.
- After soldering the LEDs, the package should be protected from mechanical shock or vibration until the LEDs have reached 40 °C or below.
- Precautions must be taken as mechanical stress on the LEDs may be caused by PCB warpage or from the clinching and cutting of the LED leads.
- When it is necessary to clam the LEDs during soldering, it is important to ensure no mechanical stress is exerted on the LEDs.
- Cut the LED lead at normal room temperature. Lead cutting at high temperature may cause failure of the LEDs.

Refer to "<http://www.cree.com/led-components/media/documents/sh-HB.pdf>" for soldering & handling details.

## PACKAGING

### Features:

- The LEDs are packed in cardboard boxes after packaging in normal or anti-electrostatic bags.
- Cardboard boxes will be used to protect the LEDs from mechanical shock during transportation.
- The boxes are not water resistant, and they must be kept away from water and moisture.
- The Bulk Pack types of packaging.
- Max 500 pcs per bulk and Max 2500 pcs per ammo.

### Bulk Pack Packaging Type:

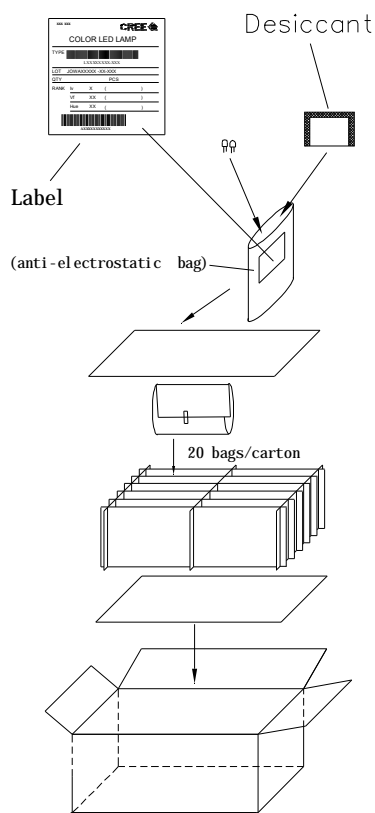

### Ammo Pack Packaging Type:

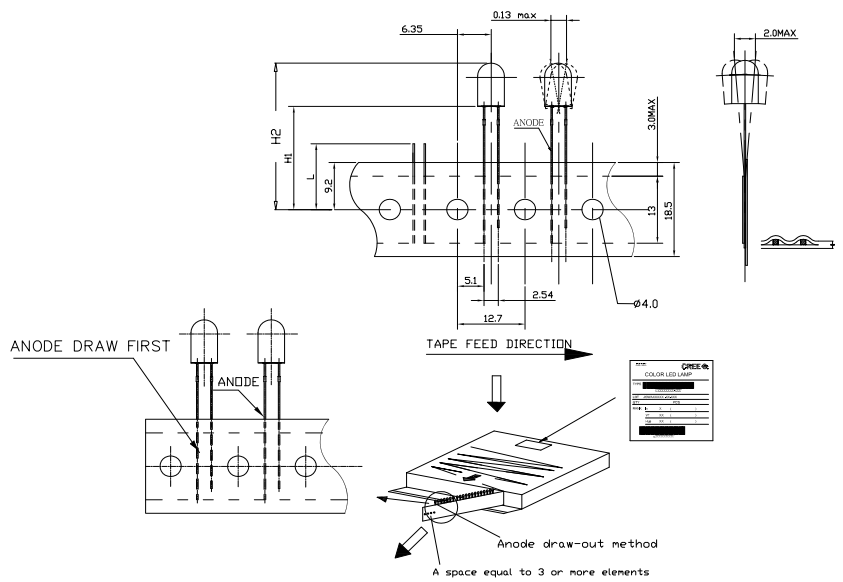

## Looking for pricing, stock, or lifecycle information?

Click below to explore more details on WIN SOURCE:

 [View C503B-AAS-CY0B0251 on WIN SOURCE](#)

 [Cree Inc. Information](#)

## Optimize Your Supply Chain with WIN SOURCE Solutions

-  Global Sourcing Solution
-  Obsolete Management
-  Cost Control Management
-  Shortage Management
-  Alternative Solution
-  Excess Inventory Management