

4-Lane DisplayPort™ Rev 1.2 Compliant Switch

Features

- 4-lane, 1:2 mux/demux that will support RBR, HBR1, or HBR2
- 1-channel 1:2 mux/demux for DP_HPDP signal
- 1-differential channel 1:2 mux/demux for DP_Aux signal with support up to 720Mbps
- -1.6dB Insertion Loss for Dx channels @ 2.7 GHz (TQFN)
- -3dB Bandwidth for Dx channels: 4.6GHz (TQFN)
- Return loss for Dx channels @ 2.7GHz: -16dB (TQFN)
- Low Bit-to-Bit Skew , 5ps typ (between '+' and '-' bits)
- Low Crosstalk for high speed channels: -28dB@5.4 Gbps
- Low Off Isolation for high speed channels: -22dB@5.4 Gbps
- V_{DD} Operating Range: 3.3V +/-10%
- ESD Tolerance: 2kV HBM
- Low channel-to-channel skew, 35ps max
- Packaging (Pb-free & Green):
 - 42 TQFN (ZHE)
 - 48 BGA (NEE)

Description

Pericom Semiconductor's PI3VDP12412 mux/demux is targeted for next generation digital video signals. This device can be used to connect a DisplayPort™ Source to two Independent DisplayPort Sinks or to connect two DisplayPort sources to a single DP display.

PI3VDP12412 supports DisplayPort 1.2 which requires a data rate of 5.4 Gbps. PI3VDP12412 offers excellent signal integrity at this high data rate with very low insertion loss, good return loss, and very small crosstalk.

PI3VDP12412 is available in two package types, a 5 mm x 5 mm 48 BGA and a 3.5 mm x 9 mm 42 TQFN. The BGA consumes less board space. The TQFN achieves slightly better signal integrity.

Application

Routing of DisplayPort signals with low signal attenuation between source and sink.

Block Diagram

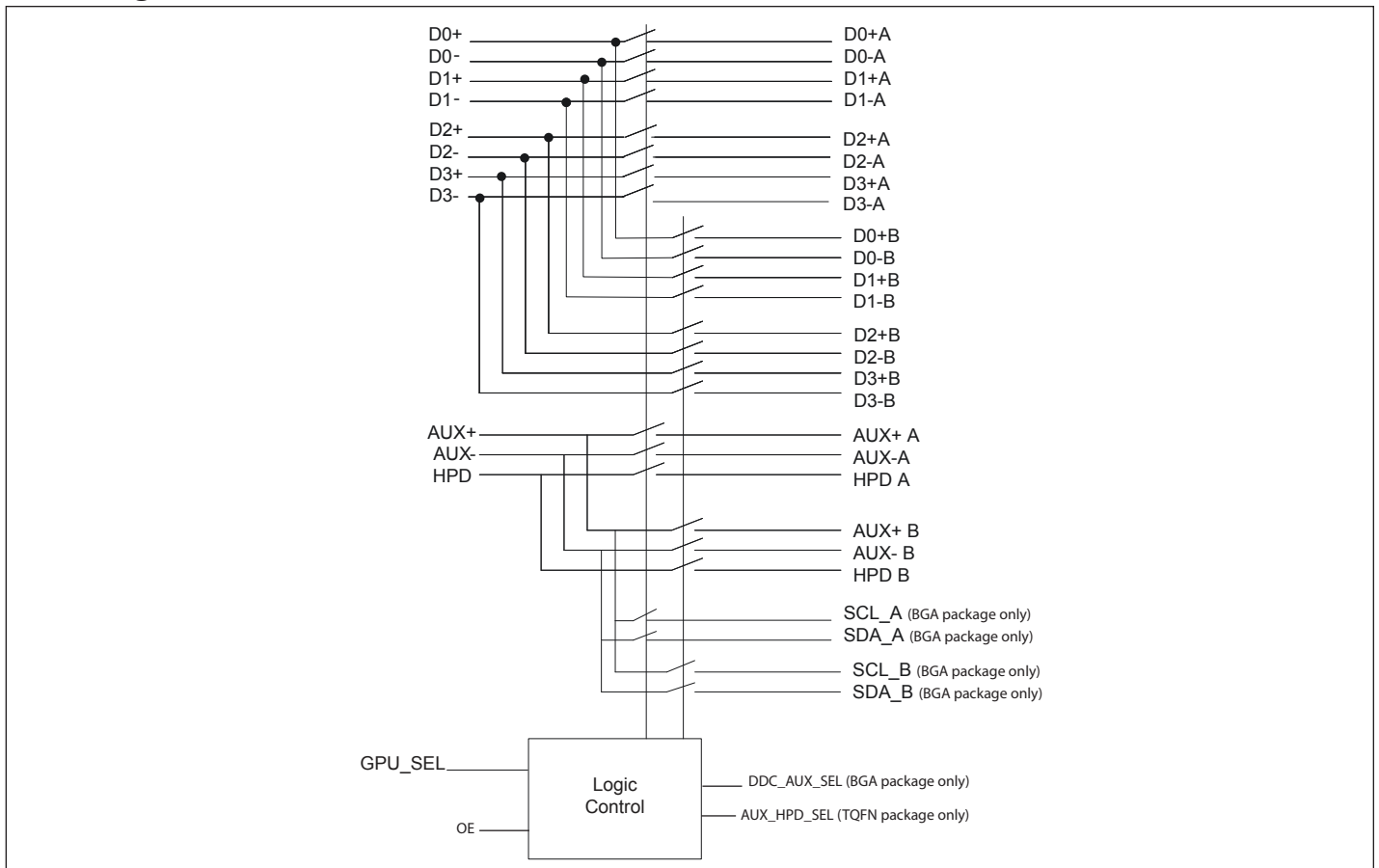

Pin Assignment (TQFN-42, ZHE)

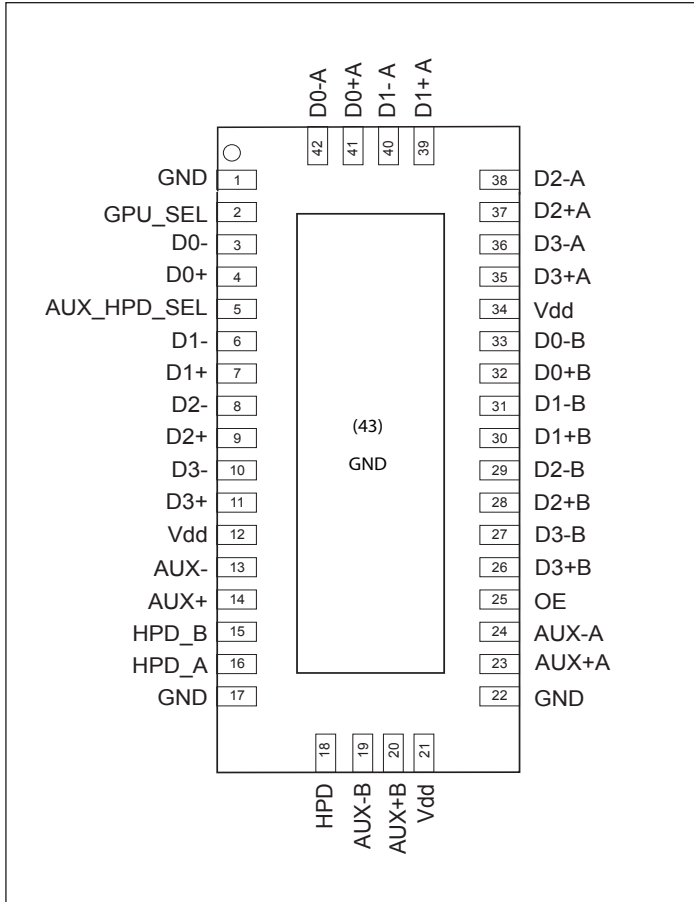

Truth Table for 42 pin package

| OE | GPU_SEL | AUX_HPD_SEL | Function |
|------|---------|-------------|---|
| High | Low | Low | Port A active for all channels |
| High | Low | High | Port A for HS, port B for HPD/AUX |
| High | High | Low | Port B for HS, port A for HPD/AUX |
| High | High | High | Port B active for all channels |
| Low | x | x | All I/O's are hi-z and IC is power down |

Pin Assignment (48-Ball BGA, NEE)

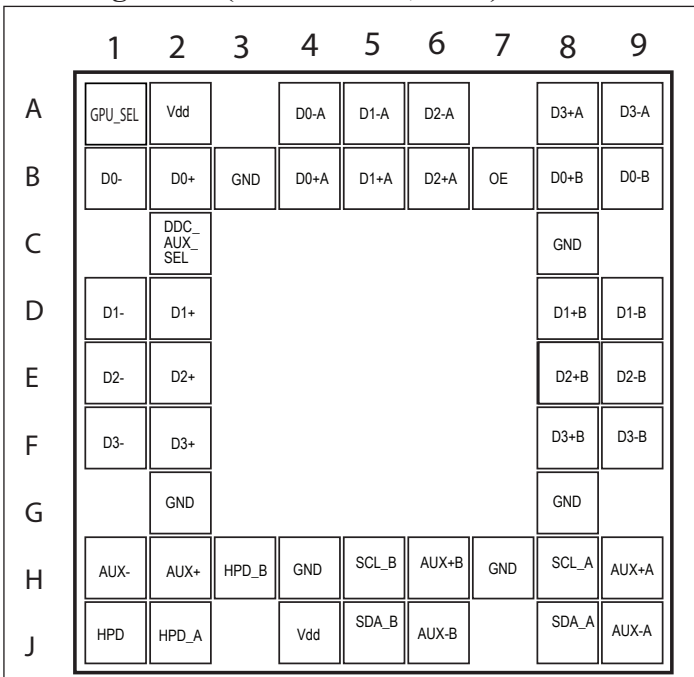

| OE | GPU_SEL | DDC_AUX_SEL | Function |
|------|---------|-------------|--|
| High | Low | Low | Port A active for AUX, HPD & HS channel |
| High | Low | High | Port A active for DDC, HPD, & HS channel |
| High | High | Low | Port B active for AUX, HPD & HS channel |
| High | High | High | Port B active for DDC, HPD & HS channel |
| Low | x | x | all I/Os are hi-z and IC is power down |

| 42ZHE pin# | 48NEE pin# | pin Name | Signal Type | Description |
|------------|------------|----------|-------------|---|
| 2 | A1 | GPU_SEL | I | switch logic control. different function for different package options: 42pin TQFN package: If HIGH, then path B is selected for high speed channels only If LOW, then path A is selected for high speed channels only 48ball BGA package: If HIGH, then path B is selected for all channels If LOW, then path A is selected for all channels |
| 3 | B1 | D0- | I/O | negative differential signal 0 for COM port |
| 4 | B2 | D0+ | I/O | positive differential signal 0 for COM port |
| 6 | D1 | D1- | I/O | negative differential signal 1 for COM port |
| 7 | D2 | D1+ | I/O | positive differential signal 1 for COM port |
| 8 | E1 | D2- | I/O | negative differential signal 2 for COM port |
| 9 | E2 | D2+ | I/O | positive differential signal 2 for COM port |
| 10 | F1 | D3- | I/O | negative differential signal 3 for COM port |
| 11 | F2 | D3+ | I/O | positive differential signal 3 for COM port |
| 1 | B3 | GND | Ground | Ground |
| 13 | H1 | AUX- | I/O | negative differential signal for AUX COM port |
| 14 | H2 | AUX+ | I/O | positive differential signal for AUX COM port |
| 18 | J1 | HPD | I/O | HPD for COM port |
| 16 | J2 | HPD_A | I/O | HPD for port A |
| 15 | H3 | HPD_B | I/O | HPD for port B |
| 17 | C8 | GND | Ground | Ground |
| 12 | J4 | VDD | Pwr | 3.3V +/-10% power supply |
| | G2 | GND | Ground | Ground |
| 20 | H6 | AUX+B | I/O | positive differential signal for AUX, port B |
| 19 | J6 | AUX-B | I/O | negative differential signal for AUX, port B |
| 23 | H9 | AUX+A | I/O | positive differential signal for AUX, port A |
| 24 | J9 | AUX-A | I/O | negative differential signal for AUX, port A |
| 22 | G8 | GND | Ground | Ground |
| 26 | F8 | D3+B | I/O | positive differential signal 3 for portB |
| 27 | F9 | D3-B | I/O | negative differential signal 3 for portB |
| 28 | E8 | D2+B | I/O | positive differential signal 2 for portB |
| 29 | E9 | D2-B | I/O | negative differential signal 2 for portB |
| 30 | D8 | D1+B | I/O | positive differential signal 1 for portB |
| 31 | D9 | D1-B | I/O | negative differential signal 1 for portB |
| 32 | B8 | D0+B | I/O | positive differential signal 0 for portB |

(Continued)

| 42ZHE pin# | 48NEE pin# | pin Name | Signal Type | Description |
|------------|------------|------------------|-------------|---|
| 33 | B9 | D0-B | I/O | negative differential signal 0 for portB |
| 35 | A8 | D3+A | I/O | positive differential signal 3 for port A |
| 36 | A9 | D3-A | I/O | negative differential signal 3 for port A |
| | H4 | GND | Ground | |
| 37 | B6 | D2+A | I/O | positive differential signal 2 for port A |
| 38 | A6 | D2-A | I/O | negative differential signal 2 for port A |
| 39 | B5 | D1+A | I/O | positive differential signal 1 for port A |
| 40 | A5 | D1-A | I/O | negative differential signal 1 for port A |
| 41 | B4 | D0+A | I/O | positive differential signal 0 for port A |
| 42 | A4 | D0-A | I/O | negative differential signal 0 for port A |
| 21 | A2 | VDD | Pwr | Power |
| 34 | | VDD | Pwr | Power |
| N/A | C2 | DDC_ AUX_SEL | I | toggles between passing DDC channels through or AUX channels through If HIGH, then path DDC signals are passed through (depending on port selection via GPU_SEL) If LOW, then path AUX signals are passed through (depending on port selection via GPU_SEL) |
| 5 | N/A | AUX_HPDP_ SEL | I | switches only the AUX and HPD channels from port A vs. port B |
| N/A | H5 | SCL_B | I/O | DDC_clock channel for port B |
| N/A | H7 | GND | Ground | |
| N/A | H8 | SCL_A | I/O | DDC_clock channel for port A |
| N/A | J5 | SDA_B | I/O | DDC_data channel for port B |
| N/A | J8 | SDA_A | I/O | DDC_data channel for port A |
| 25 | B7 | OE | I | Output enable. if OE is high, IC is enabled. If OE is low, then IC is power down and all I/Os are hi-z |
| 43 | N/A | Center pad | Ground | Ground |

Maximum Ratings

(Above which useful life may be impaired. For user guidelines, not tested.)

| | |
|--|--------------------------|
| Storage Temperature | -65°C to +150°C |
| Supply Voltage to Ground Potential | -0.5V to +4.2V |
| DC Input Voltage | -0.5V to V _{DD} |
| DC Output Current | 120mA |
| Power Dissipation | 0.5W |

Note: Stresses greater than those listed under MAXIMUM RATINGS may cause permanent damage to the device. This is a stress rating only and functional operation of the device at these or any other conditions above those indicated in the operational sections of this specification is not implied. Exposure to absolute maximum rating conditions for extended periods may affect reliability.

DC Electrical Characteristics for Switching over Operating Range (T_A = -40°C to +105°C, V_{DD} = 3.3V ±10%)

| Parameter | Description | Test Conditions ⁽¹⁾ | Min | Typ ⁽²⁾ | Max | Units |
|---------------------|---|--|------|--------------------|------|-------|
| V _{IH} | Input HIGH Voltage | Guaranteed HIGH level | 1.5 | | | V |
| V _{IL} | Input LOW Voltage | Guaranteed LOW level | | | 0.75 | |
| V _{IK} | Clamp Diode Voltage (HS Channel) | V _{DD} = Max., I _{IN} = -18mA | | -1.6V | -1.8 | |
| V _{IK} | Clamp Diode Voltage (Aux, Cntrl) | V _{DD} = Max., I _{IN} = -18mA | | -0.7 | -1.5 | |
| I _{IH} | Input HIGH Current | V _{DD} = Max., V _{IN} = V _{DD} | | | ±5 | µA |
| I _{IL} | Input LOW Current | V _{DD} = Max., V _{IN} = GND | | | ±5 | |
| I _{OFF_SB} | I/O leakage when part is off for side-band signals only (DDC, AUX, HPD) | V _{DD} = 0V, V _{INPUT} = 0V to 3.6V | | | 20 | |
| R _{ON_HS} | On resistance between input to output for high speed signals | V _{DD} = 3.0V, V _{input} = -0.35V to 2V, I _{INPUT} = 20mA | | 10.0 | | Ohm |
| R _{ON_AUX} | On resistance between input to output for side-band signals (AUX) | V _{DD} = 3.0V, V _{input} = 0 to 3.3V, I _{INPUT} = 20mA | | 7 | | Ohm |
| R _{ON_DDC} | On resistance between input to output for DDC channel | V _{DD} = 3.0V, V _{input} = 0V, I _{INPUT} = 20mA | | 10 | | Ohm |
| Aux _{ss} | Signal Swing Tolerance in Aux path | V _{DD} = 3.0V | -0.5 | | 3.6 | V |
| HPD _I | Input voltage on HPD path | | | | 5.5 | V |
| HPD _O | Output voltage tolerance on HPD path | HPD input from 3.3V to 5.25V | | 3.3 | 3.6 | V |

Power Supply Characteristics (T_A = -40°C to +105°C)

| Parameter | Description | Test Conditions ⁽¹⁾ | Min | Typ ⁽²⁾ | Max | Units |
|------------------|--------------------------------|---|-----|--------------------|-----|-------|
| I _{DD} | Power Supply Current | V _{DD} = 3.3V, OE = 3.3V, V _{IN} = GND or V _{DD} | | 0.4 | 1 | mA |
| I _{DDQ} | Quiescent Power Supply Current | V _{DD} = 3.3V, OE = GND | | 1 | | µA |

- For Max. or Min. conditions, use appropriate value specified under Electrical Characteristics for the applicable device type.
- Typical values are at V_{DD} = 3.3V, T_A = 25°C ambient and maximum loading.

Dynamic Electrical Characteristics over Operating Range ($T_A = -40^\circ$ to $+105^\circ\text{C}$, $V_{DD} = 3.3\text{V} \pm 10\%$)

| Parameter | Description | Test Conditions ¹ | Min | Typ ² | MAX | Units |
|-----------------------|--|-----------------------------------|--------------|------------------|-------|-------|
| X _{TALK} | Crosstalk on High Speed Channels | See Fig. 1 for Measurement Setup | f = 2.7 GHz | -28 | -25 | dB |
| | | | f = 1.35 GHz | -32 | -28 | |
| O _{IRR} | OFF Isolation on High Speed Channels | See Fig. 2 for Measurement Setup, | f = 2.7 GHz | -22 | -20 | |
| | | | f = 1.35 GHz | -30 | -27 | |
| I _{LOSS} | Differential Insertion Loss on High Speed Channels | @5.4Gbps (see figure 3) | TQFN package | -1.8 | -1.6 | dB |
| | | | BGA package | -2.0 | -1.8 | |
| R _{loss} | Differential Return Loss on high speed channels | @ 2.7GHz (5.4Gbps) | TQFN package | | -16.0 | dB |
| | | | BGA package | | -14 | |
| BW _{Dx±} | Bandwidth -3dB for Main high speed path (Dx±) | See figure 3 | TQFN package | 4.1 | 4.6 | GHz |
| | | | BGA package | 3.7 | 4.1 | |
| BW _{AUX/HPD} | -3dB BW for AUX and HPD signals | See figure 3 | 1.35 | 1.5 | | GHz |
| T _{sw a-b} | time it takes to switch from port A to port B | | | | 1 | us |
| T _{sw b-a} | time it takes to switch from port B to port A | | | | 1 | us |
| T _{startup} | V _{DD} valid to channel enable | | | | 10 | us |
| T _{wakeup} | Enabling output by changing OE from low to High | | | | 10 | us |

1. For Max. or Min. conditions, use appropriate value specified under Electrical Characteristics for the applicable device type.

2. Typical values are at $V_{DD} = 3.3\text{V}$, $T_A = 25^\circ\text{C}$ ambient and maximum loading.

Switching Characteristics ($T_A = -40^\circ$ to $+105^\circ\text{C}$, $V_{DD} = 3.3\text{V} \pm 10\%$)

| Parameter | Description | Min. | Typ. | Max. | Units |
|--------------------|---|------|------|------|-------|
| T _{pd} | Propagation delay (input pin to output pin) on all channels | | 80 | | ps |
| t _{b-b} | Bit-to-bit skew within the same differential pair of Dx± channels | | 5 | 7 | ps |
| t _{ch-ch} | Channel-to-channel skew of Dx± channels | | | 35 | ps |

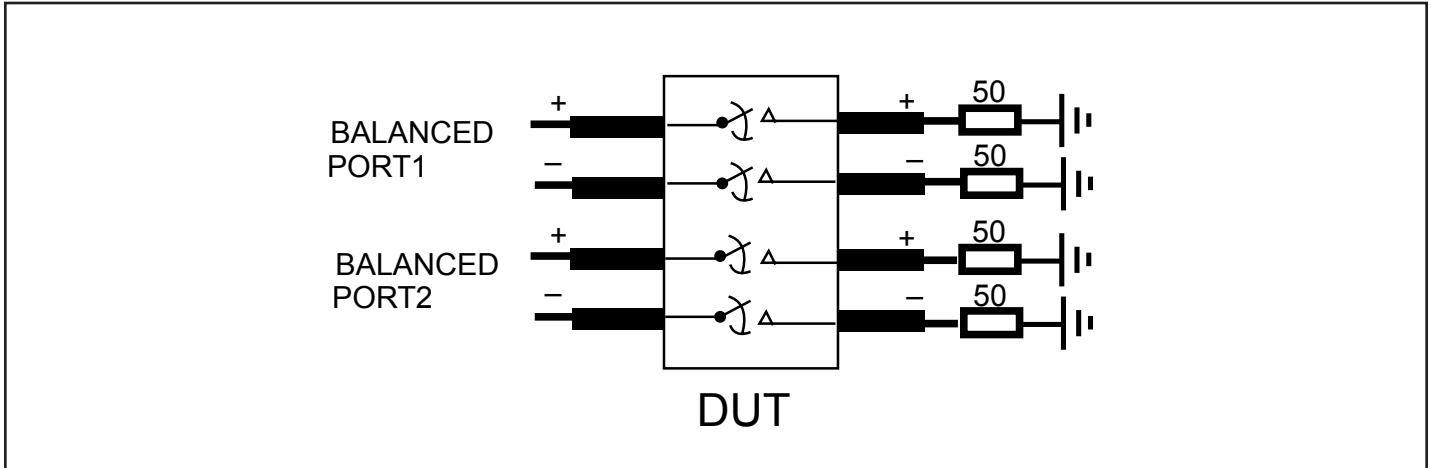

Fig 1. Crosstalk Setup

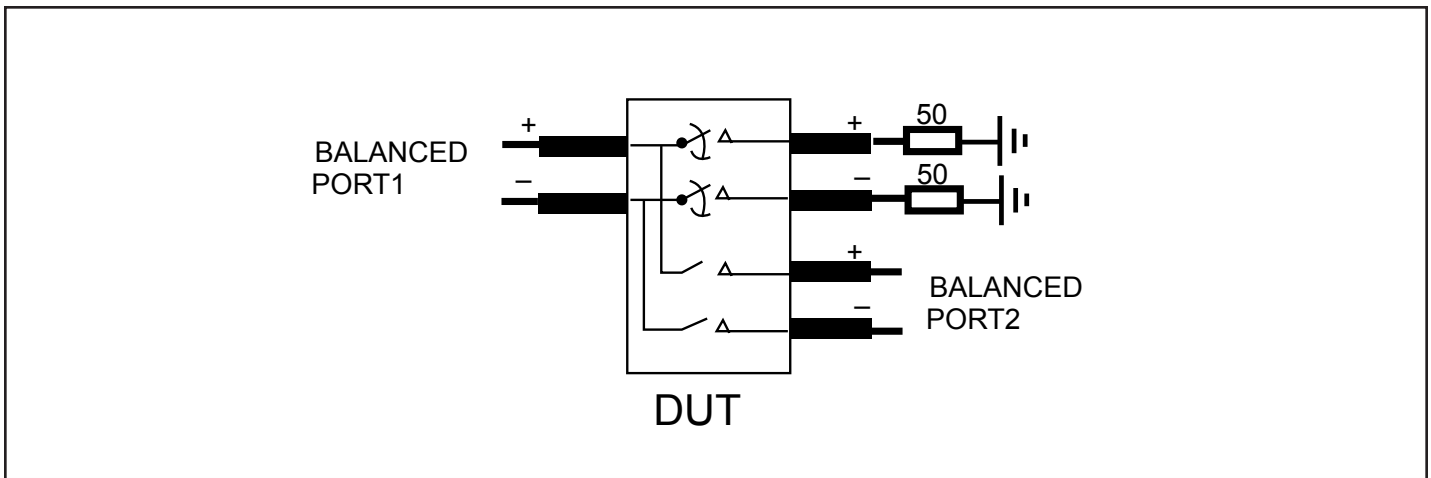

Fig 2. Off-isolation setup

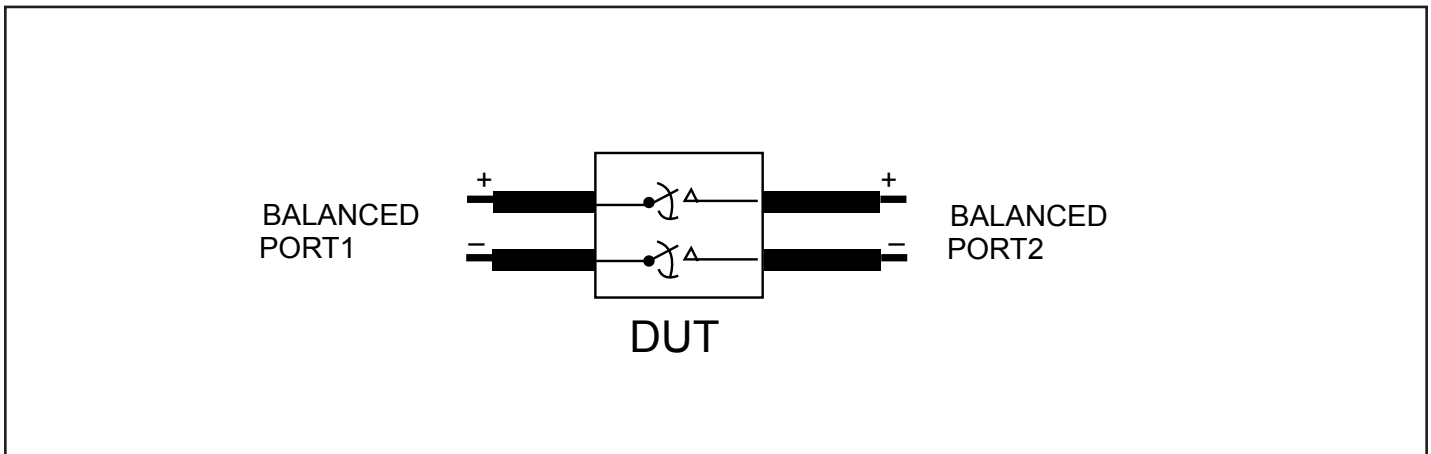

Fig 3. Differential Insertion Loss

Test Circuit for Dynamic Electrical Characteristics

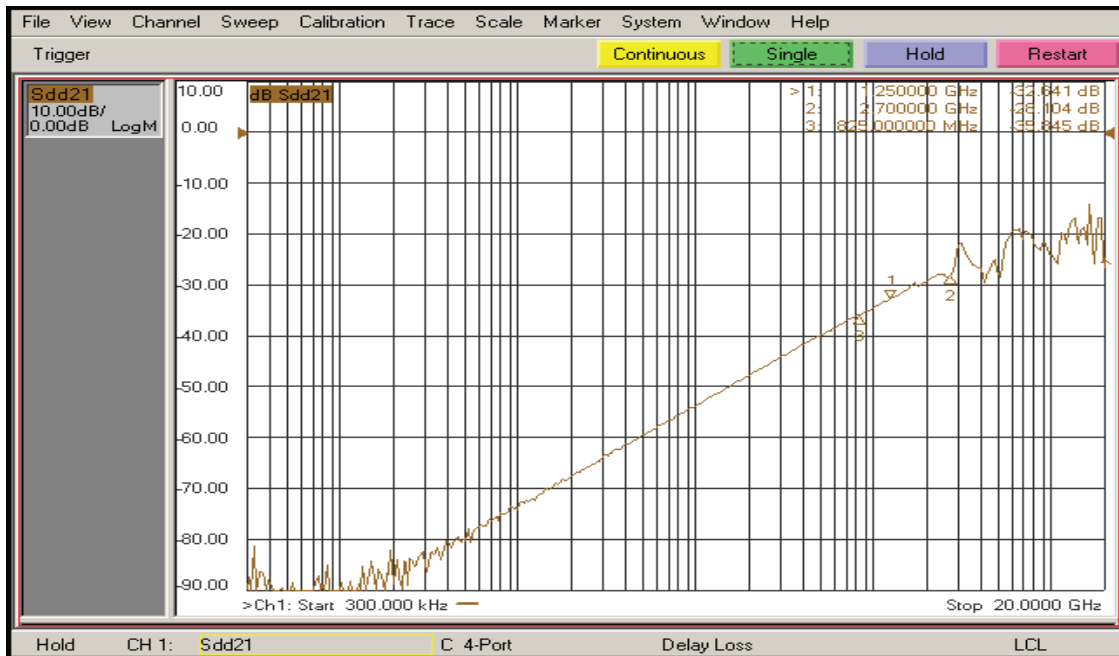
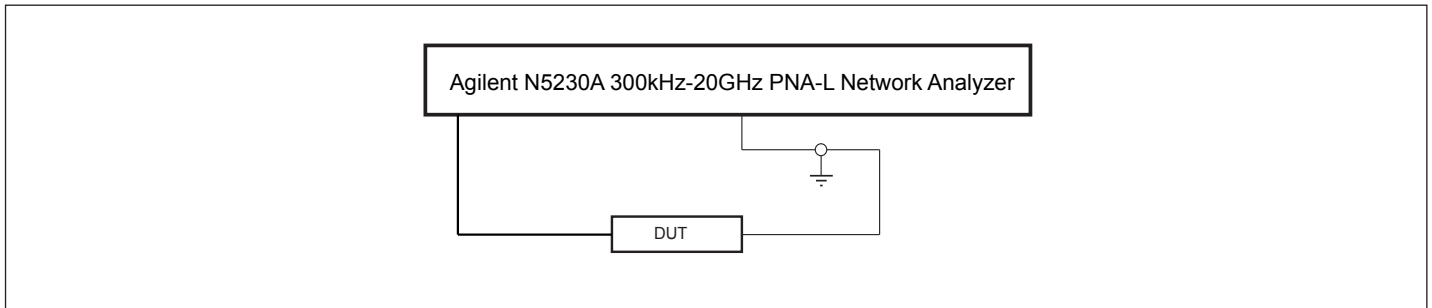

Fig 4. Crosstalk

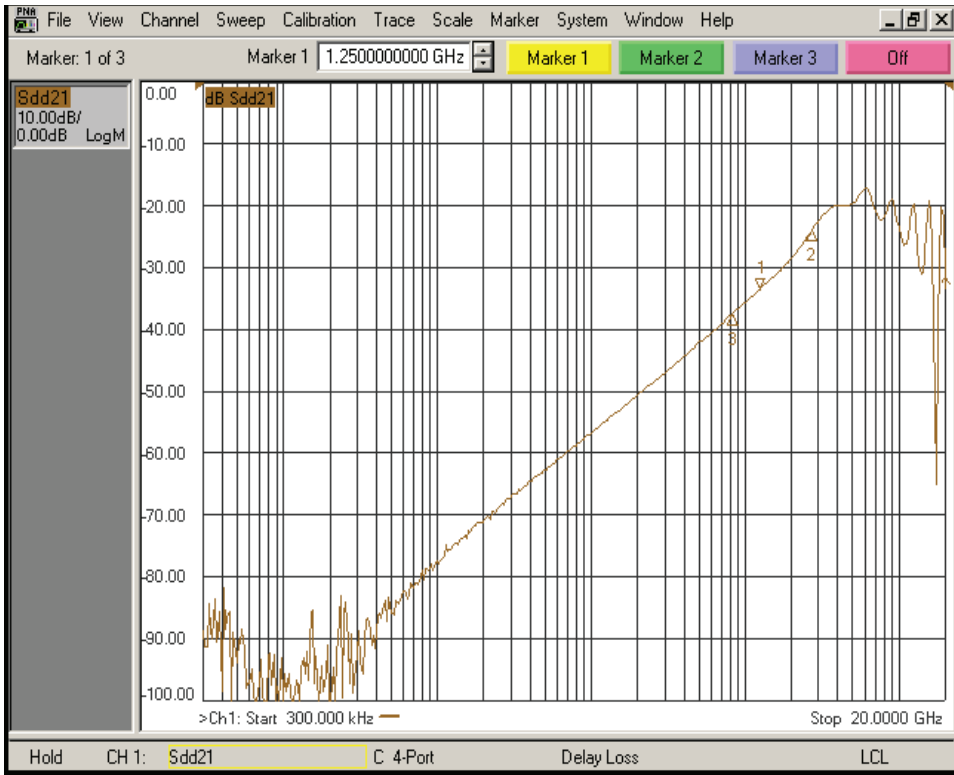

Fig 5. Off Isolation

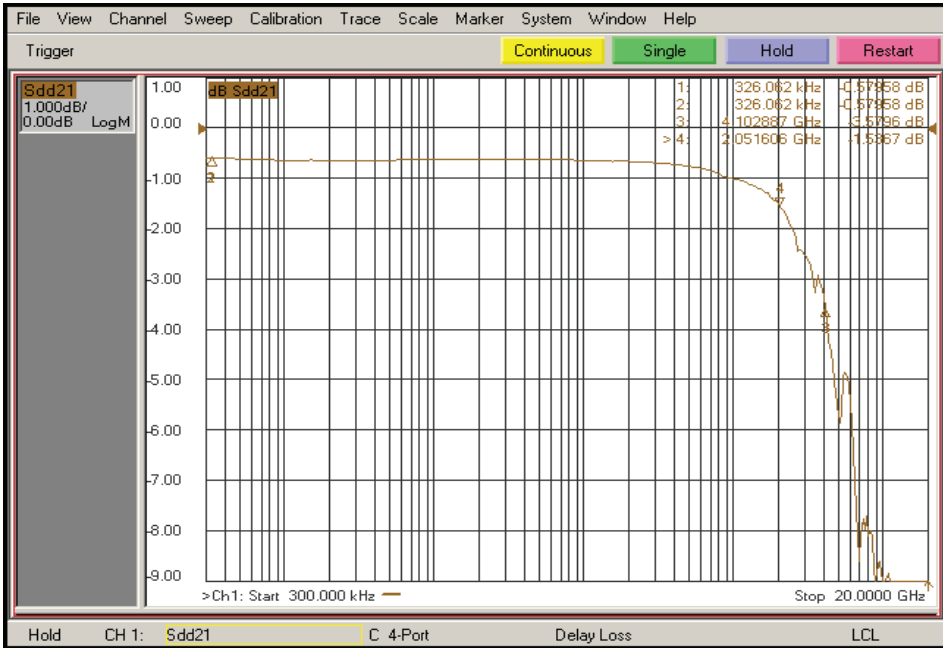
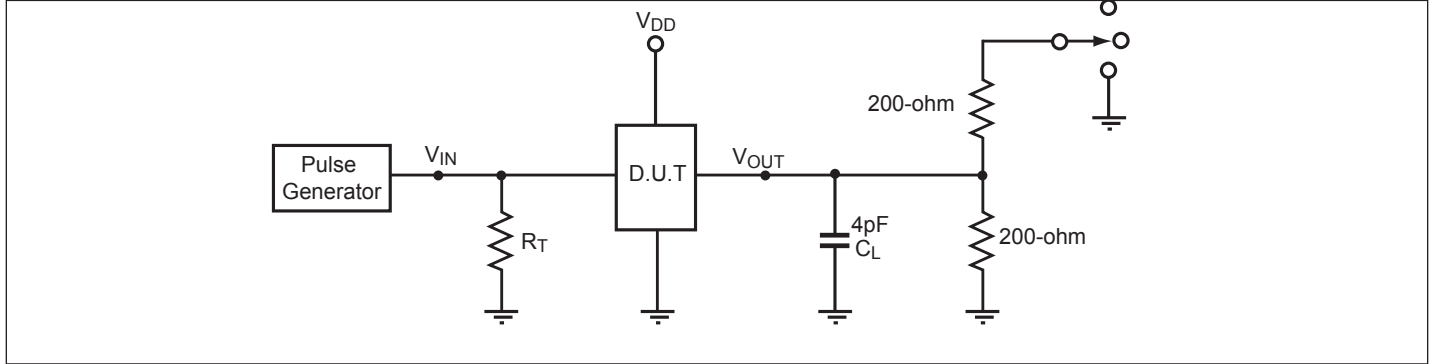

Fig 6. Insertion Loss

Test Circuit for Electrical Characteristics(1-5)



Notes:

1. C_L = Load capacitance: includes jig and probe capacitance.
2. R_T = Termination resistance: should be equal to Z_{OUT} of the Pulse Generator
3. Output 1 is for an output with internal conditions such that the output is low except when disabled by the output control.
4. Output 2 is for an output with internal conditions such that the output is high except when disabled by the output control.
5. All input impulses are supplied by generators having the following characteristics: $PRR \leq$ MHz, $Z_O = 50\Omega$, $t_R \leq 2.5ns$, $t_F \leq 2.5ns$.
6. The outputs are measured one at a time with one transition per measurement.

Switching Waveforms

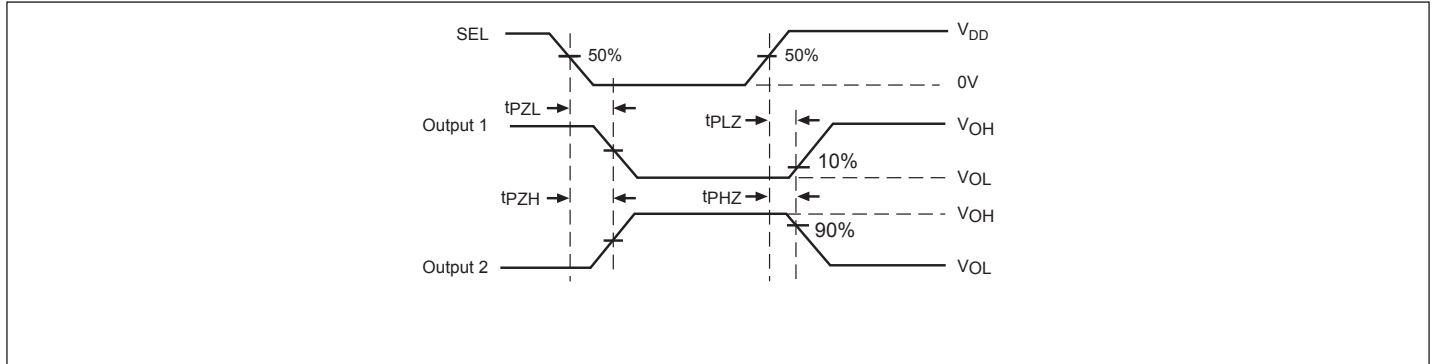

Voltage Waveforms Enable and Disable Times

Switch Positions

| Test | Switch |
|--|--------------|
| t_{PLZ} , t_{PZL} (output on B-side) | $2 * V_{DD}$ |
| t_{PHZ} , t_{PZH} (output on B-side) | GND |
| Prop Delay | Open |

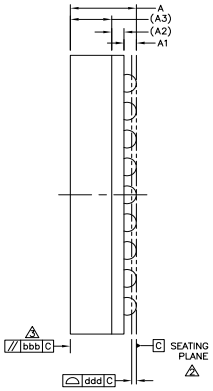
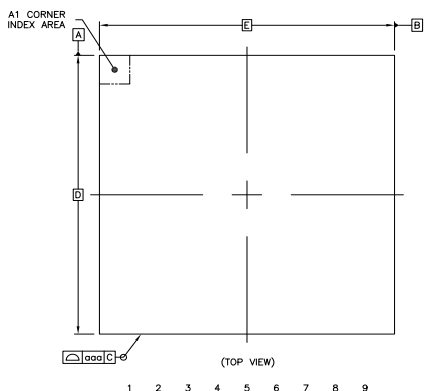

| | SYMBOL | COMMON DIMENSIONS | | |
|-----------------------------|--------|-------------------|-------|------|
| | | MIN. | NOR. | MAX. |
| TOTAL THICKNESS | A | --- | --- | 1.1 |
| STAND OFF | A1 | 0.16 | --- | 0.26 |
| SUBSTRATE THICKNESS | A2 | --- | 0.21 | REF |
| MOLD THICKNESS | A3 | --- | 0.54 | REF |
| BODY SIZE | D | --- | 5 | BSC |
| | E | --- | 5 | BSC |
| BALL DIAMETER | | --- | 0.3 | |
| BALL OPENING | | --- | 0.275 | |
| BALL WIDTH | b | 0.27 | --- | 0.37 |
| BALL PITCH | e | --- | 0.5 | BSC |
| BALL COUNT | n | --- | 48 | |
| EDGE BALL CENTER TO CENTER | D1 | --- | 4 | BSC |
| | E1 | --- | 4 | BSC |
| BODY CENTER TO CONTACT BALL | SD | --- | --- | BSC |
| | SE | --- | --- | BSC |
| PACKAGE EDGE TOLERANCE | ooo | --- | 0.1 | |
| MOLD FLATNESS | bbb | --- | 0.2 | |
| COPLANARITY | ddd | --- | 0.08 | |
| BALL OFFSET (PACKAGE) | eee | --- | 0.15 | |
| BALL OFFSET (BALL) | fff | --- | 0.08 | |
| | | | | |
| | | | | |
| | | | | |
| | | | | |

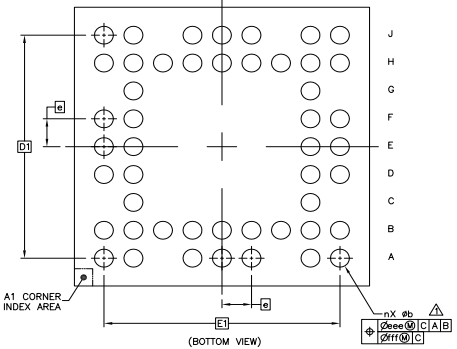

- Notes:**
1. Controlling dimensions in millimeters
 2. Ref: JEDEC MO-195C

| | |
|--|--|
| <p>PERICOM Enabling Serial Connectivity</p> | DATE: 07/15/11 |
| | DESCRIPTION: 48-Pin, Thin Fine Pitch Ball Grid Array TFBGA |
| PACKAGE CODE: NE48 | |
| DOCUMENT CONTROL #: PD-2101 | REVISION: -- |

12-0332

Note:
For latest package info, please check: <http://www.pericom.com/products/packaging/mechanicals.php>

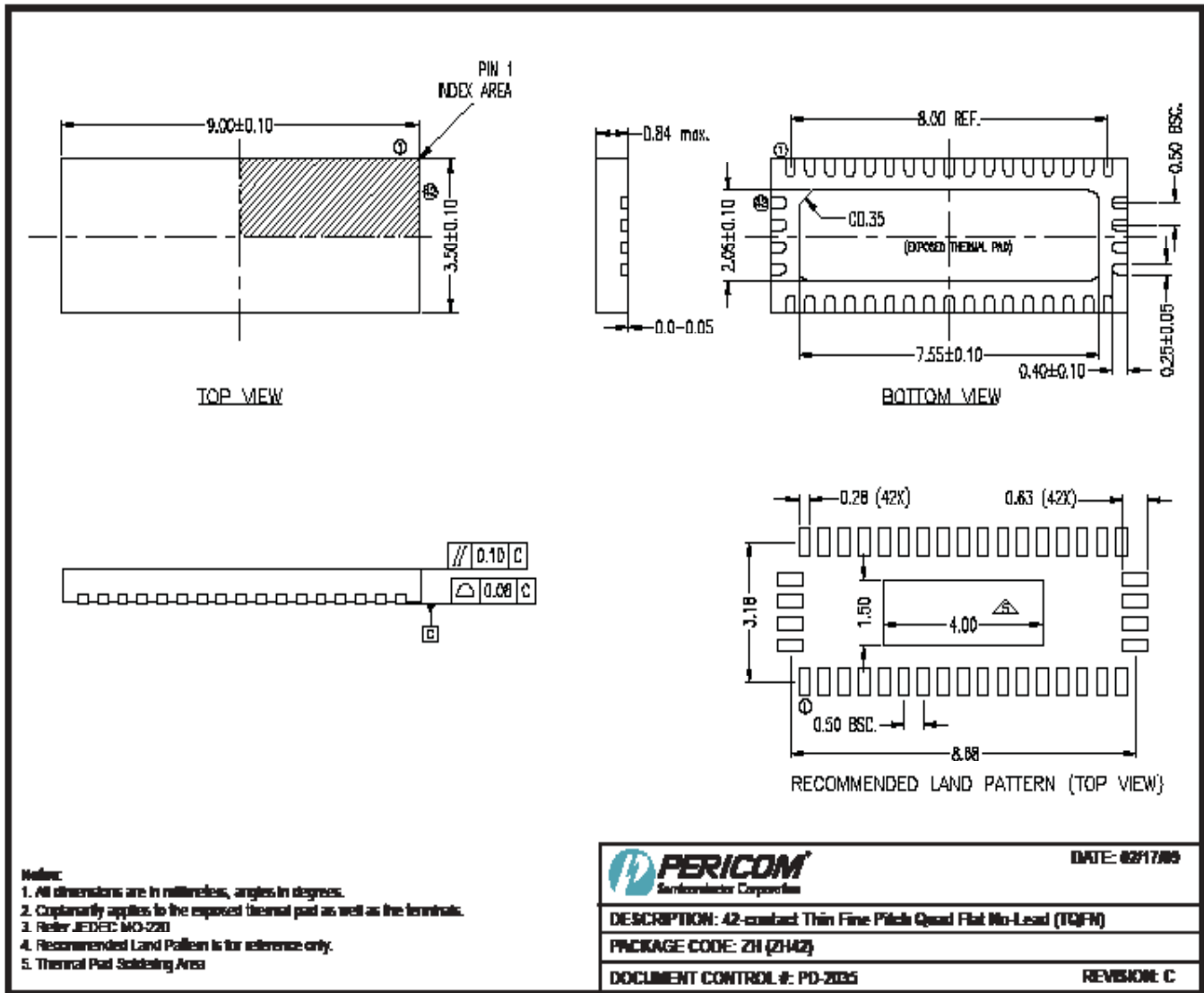

09-0116

Note:

For latest package info, please check: <http://www.pericom.com/products/packaging/mechanicals.php>

Ordering Information

| Ordering Code | Package Code | Package Description |
|----------------|--------------|----------------------------------|
| PI3VDP12412ZHE | ZH | Pb-free & Green, 42-contact TQFN |
| PI3VDP12412NEE | NE | Pb-free & Green, 48-ball BGA |

Notes:

- Thermal characteristics can be found on the company web site at www.pericom.com/packaging/
- "E" denotes Pb-free and Green
- Adding an "X" at the end of the ordering code denotes tape and reel packaging

Looking for pricing, stock, or lifecycle information?

Click below to explore more details on WIN SOURCE:

 [View PI3VDP12412NEEX on WIN SOURCE](#)

 [Diodes Incorporated Information](#)

Optimize Your Supply Chain with WIN SOURCE Solutions

-  Global Sourcing Solution
-  Obsolete Management
-  Cost Control Management
-  Shortage Management
-  Alternative Solution
-  Excess Inventory Management