



THE DATASHEET OF LED6001TR



PWM-dimmable single channel LED driver with integrated boost controller

Datasheet - production data



Features

- Switching controller section
 - 5.5 V to 36 V input voltage range
 - Very low shutdown current: $I_{SHDN} < 10 \mu A$
 - Internal +5 V LDO for gate driver supply
 - Internal +3.3 V LDO for device supply
 - Fixed frequency peak current mode control
 - Adjustable (100 kHz to 1 MHz) switching frequency
 - External synchronization for multi-device applications
 - High performance external MOSFET driver
 - Cycle-by-cycle external MOSFET OCP
 - Fixed internal soft-start
 - Programmable output OVP
 - Boost, buck-boost and SEPIC topologies supported
 - Thermal shutdown with autorestart
 - Output short-circuit detection
- LED control section
 - Up to 60 V output voltage
 - Constant current control loop
 - High-side output current sensing circuitry
 - 30 to 300 mV differential sensing voltage
 - $\pm 4\%$ output current reference accuracy
 - Output overcurrent protection
 - Sensing resistor failure protection
 - PWM dimming with auxiliary series switch
 - Analog dimming

Applications

- Indoor and architectural LED lighting
- Emergency LED lighting
- Off-grid LED street lighting
- White goods
- Gaming/gambling machines

Description

The LED6001 device is a LED driver that combines a boost controller and a high-side current sensing circuitry optimized for driving one string of high-brightness LEDs. The device is compatible with multiple topologies such as boost, SEPIC and floating load buck-boost. The brightness of the LEDs can be controlled through PWM dimming and analog dimming (10:1 ratio) by means of two independent pins. Enhanced PWM dimming can be obtained thanks to a MOSFET in series with the LED string and directly driven by a dedicated pin.

The high-side current sensing, in combination with a P-channel MOSFET, provides an effective protection in case the positive terminal of the LED string is shorted to ground. The high precision current sensing circuitry allows a LED current regulation reference within $\pm 4\%$ accuracy over the whole temperature range and production spread.

A fault output (open-drain) informs the host system about faulty conditions: device overtemperature, output overvoltage (disconnected LED string) and LED overcurrent.

Table 1. Device summary

Order code	Package	Packaging
LED6001	HTSSOP-16 (exposed pad)	Tube
LED6001TR		Tape and reel

Contents

1	Typical application circuit	3
2	Pin function	4
3	Block diagram	6
4	Absolute maximum ratings	7
5	Recommended operating conditions	8
6	Electrical characteristics	9
7	Device description	12
7.1	Device supply	12
7.2	Boost controller	12
7.2.1	Turn on and power-down sequences	12
7.2.2	Boost controller operation	13
7.2.3	Boost converter stability and slope compensation	14
7.2.4	Switching frequency oscillator and external synchronization	16
7.3	LED current regulation and brightness control	17
7.4	Device protections	20
7.4.1	Linear regulators undervoltage lockout	20
7.4.2	Power switch overcurrent	20
7.4.3	Output overvoltage and OVFB pin disconnection	20
7.4.4	Output rail disconnection detection or output short-circuit to ground ...	21
7.4.5	Thermal shutdown	22
8	Package information	23
9	Revision history	25

1 Typical application circuit

Figure 1. Basic application circuit schematic (boost topology)

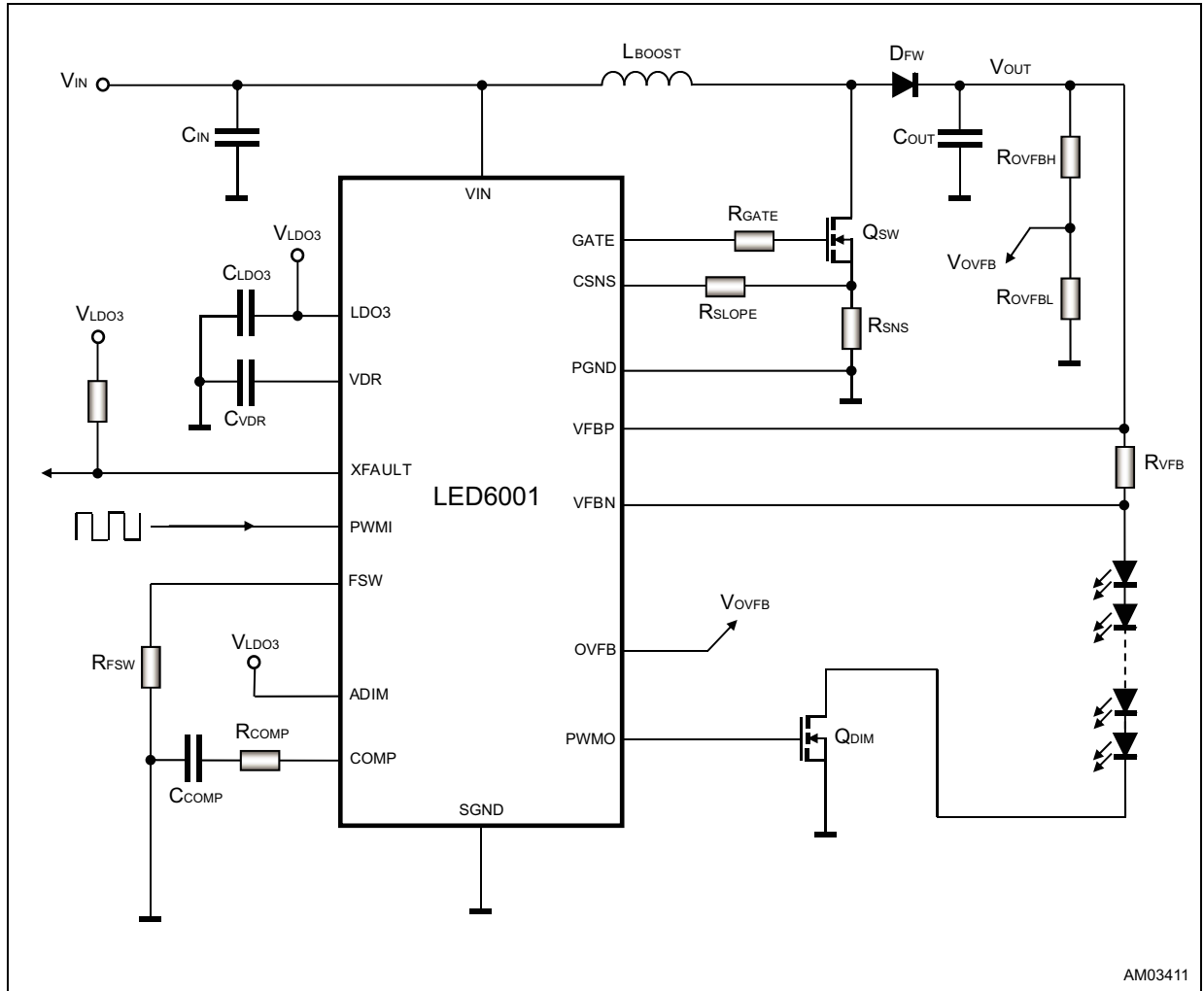

2 Pin function

Figure 2. Pin connection (through top view)

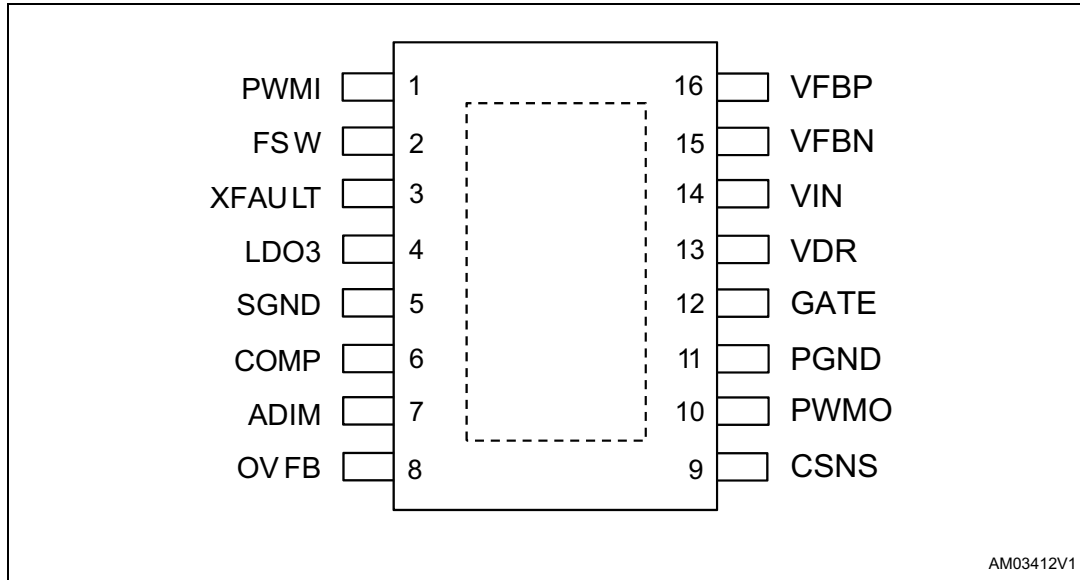
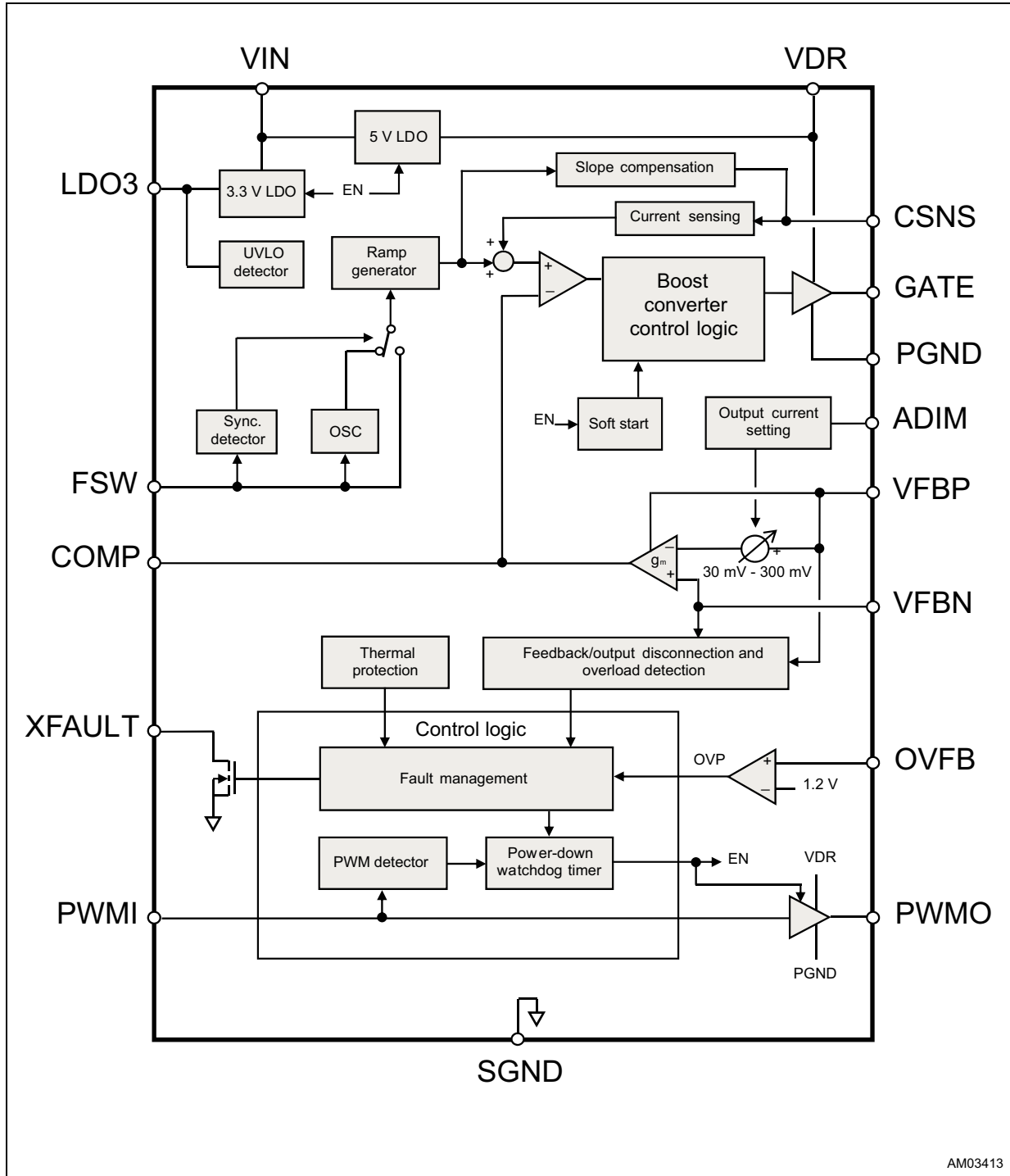

Table 2. Pin description

No.	Pin	
1	PWMI	Device enable and PWM dimming control input.
2	FSW	Switching frequency setting. A resistor between this pin and SGND sets the desired switching frequency. This pin is also used as synchronization input. If tied high (e.g. connected to LDO3 pin) a 600 kHz switching frequency is set.
3	XFAULT	Fault indicator, open-drain output. This pin is tied low by the device in case of faulty condition. See Section 7.4 on page 20 for details.
4	LDO3	3.3 V linear regulator output and device supply. Connect a 1 μ F (typ.) bypass MLCC between this pin and SGND as close as possible to the chip.
5	SGND	Signal ground. Return for analog circuitry. All setting components must refer to this grounding pin.
6	COMP	Boost controller loop compensation. A simple RC series must be connected between this pin and SGND for proper loop compensation. See Section 7.2.3 on page 14 for details.
7	ADIM	Analog dimming control input. The current at the output is linearly controlled by the voltage applied to this pin (0.3 V to 1.2 V). When the device is set to operate in standalone mode, a partition of the LDO3 voltage must be applied to this pin through a resistor divider.
8	OVFB	Output overvoltage protection feedback input. Connect to the central tap of a resistor divider at the output.
9	CSNS	Boost controller power switch current sensing input. Connect to the source of the external power MOSFET for proper switch overcurrent protection.
10	PWMO	PWM dimming control output. This pin provides a PWM output signal (in phase with the one applied to the PWMI pin) for direct control of a dimming N-channel MOSFET.
11	PGND	Power ground. Return for the VDR linear regulator and the power switch gate drivers. Also used as reference for the power MOSFET current sensing circuitry. Connect to ground as close as possible to the quiet terminal of the power switch sensing resistor.
12	GATE	Power switch gate driver output. Connect to the gate of the power MOSFET through a small value resistor.
13	VDR	5 V linear regulator output and gate driver supply. Connect a 1 μ F (typ.) bypass MLCC between this pin and PGND as close as possible to the chip.
14	VIN	Supply voltage input. Connect this pin to the supply power rail. A 1 μ F (typ.) bypass MLCC must be connected between this pin and PGND as close as possible to the chip.
15	VFBN	Output current differential sensing input, negative terminal. Connect to the hot terminal (load side) of the high-side sensing resistor.
16	VFBP	Output current differential sensing input, positive terminal. Connect to the quiet terminal (output capacitor side) of the high-side sensing resistor.
-	TPAD	Thermal pad. Connect to a suitable ground plane area in order to ensure proper heat dissipation. Electrically connected to PGND and SGND.

3 Block diagram

Figure 3. Simplified block diagram



AM03413

4 Absolute maximum ratings

Table 3. Absolute maximum ratings

Parameter	Pin	Min.	Max.	Unit
Maximum pin voltage	VIN to SGND		40	V
	VFBP and VFBN to SGND		65	
	VDR to SGND	-0.3	6	
	LDO3 to SGND	-0.3	3.6	
	COMP, CSNS and OVFB to SGND	-0.3	3.6	
	PGND to SGND	-0.3	0.3	
	XFAULT, FSW, ADIM and GATE to SGND	-0.3	6	
	PWMI and PWMO to SGND	-0.3	6	
HBM ESD susceptibility JEDEC JS001	All pins	-2000	2000	
VIN, VFBP, VFBN and ADIM ESD susceptibility	VIN, VFBP, VFBN, ADIM to SGND	-4000	4000	
CDM ESD resistivity to SGND ANSI/ESD STM5.3.1	Corner pins	-750	750	
	Non-corner pins	-500	500	

Table 4. Thermal characteristics

Symbol	Parameter	Conditions	Min.	Typ.	Max.	Unit
$T_{J,OP}$	Operating junction temperature		-40		150	°C
T_{STG}	Storage temperature range		-50		150	
T_{SHDN}	Thermal shutdown threshold		150	160	175	
	Thermal shutdown hysteresis			20		
	XFAULT release hysteresis			40		
$R_{th,JA}^{(1)}$	Junction to ambient thermal resistance	1s0p		55		°C/W
		2s2p		45		
$R_{th,JC}$	Junction to case thermal resistance			37		

1. The device mounted on a standard JESD51-5 test board.

5 Recommended operating conditions

Table 5. Recommended operating conditions

Symbol	Parameter	Conditions	Min.	Max.	Unit
DC characteristics					
V_{VIN}	Supply input voltage range		5.5	36	V
V_{VDR}	VDR pin Input voltage range	VDR and VIN shorted together	4.7	5.5	
V_{VFBx}	Feedback input common mode voltage range		4.4	60	
V_{FB}	Feedback input differential mode voltage range	VFBP to VFBN	30	300	mV
AC characteristics					
f_{sw}	Switching frequency		100	1000	kHz
f_{PWMI}	Dimming frequency		0.1	20	
$t_{PWMI,en}$	Minimum PWMI pulse duration for device enable (turn on)	PWMI input, $f_{sw} = 800$ kHz	100		μ s
$t_{PWMI,dim}$	Minimum dimming on-time	PWMI input, $f_{sw} = 1$ MHz	6		μ s

6 Electrical characteristics

$V_{IN} = 12\text{ V}$, $V_{VFBP} = 12\text{ V}$, $V_{VFBN} = 12\text{ V}$ and $T_J = -40\text{ }^\circ\text{C}$ to $125\text{ }^\circ\text{C}$ if not otherwise specified.

Table 6. Electrical characteristics

Symbol	Parameter	Conditions	Min.	Typ.	Max.	Unit
Supply section						
V_{VIN}	Supply voltage range		5.5		36	V
	PWMI turn on threshold			1.34	1.65	
	PWMI turn off threshold		0.7	0.85	1.1	
	PWMI pull-down resistor	PMWI at 3.3 V	350	570	810	k Ω
t_{SHDN}	PWMI low to shutdown mode delay		10	15	22	ms
t_{START}	Start-up time	$C_{LDO3} = C_{VDR} = 470\text{ nF}$		100	170	μs
V_{LDO3}	3.3 V LDO output voltage	$6\text{ V} \leq V_{IN} \leq 36\text{ V}$, $I_{LDO3} = 0.5\text{ mA}$, PWMI high	3.2	3.3	3.4	V
	3.3 V LDO line regulation	$I_{LDO3} = 20\text{ mA}$, PWMI high $6\text{ V} \leq V_{IN} \leq 36\text{ V}$		5	20	mV
	3.3 V LDO load regulation	$V_{IN} = 6\text{ V}$, PWMI high $0.5\text{ mA} \leq I_{LDO3} \leq 20\text{ mA}$		90	100	
$V_{LDO3,ON}$	LDO3 undervoltage lockout upper threshold		2.2	2.8	3.0	V
$V_{LDO3,OFF}$	LDO3 undervoltage lockout lower threshold		2.5	2.7	2.9	
	LDO3 undervoltage lockout hysteresis		50	200	400	mV
	3.3 V LDO current limit	$V_{LDO3} = 3.0\text{ V}$	30	38	46	mA
V_{VDR}	5 V LDO output voltage	$6\text{ V} \leq V_{IN} \leq 36\text{ V}$ $I_{VDR} = 0.5\text{ mA}$, PWMI high	4.8	5.0	5.2	V
	5 V LDO line regulation	$I_{VDR} = 40\text{ mA}$, PWMI high $6\text{ V} \leq V_{IN} \leq 36\text{ V}$		10	40	mV
	5 V LDO load regulation	$V_{IN} = 6\text{ V}$, PWMI high $0.5\text{ mA} \leq I_{VDR} \leq 40\text{ mA}$		120	200	
	5 V LDO dropout voltage	$I_{VDR} = 25\text{ mA}$, $V_{VIN} = 4.8\text{ V}$		150	300	
$V_{VDR,ON}$	VDR undervoltage lockout upper threshold		4.3	4.6	4.7	V
$V_{VDR,OFF}$	VDR undervoltage lockout lower threshold		4.25	4.4	4.55	mV
	VDR undervoltage lockout hysteresis		20	150	300	
	5 V LDO current limit	$V_{VDR} = 4.5\text{ V}$	50	75	100	mA

Table 6. Electrical characteristics (continued)

Symbol	Parameter	Conditions	Min.	Typ.	Max.	Unit
Power consumption						
I _{VIN,SHDN}	Shutdown current	V _{IN} = 16 V, PWMI low, -40 °C ≤ T _J ≤ 25 °C	1	4	10	μA
		V _{IN} = 16 V, PWMI low, 25 °C ≤ T _J ≤ 125 °C	1	9	25	
I _{VIN,Q}	Quiescent current	V _{IN} = 16 V, PWMI to LDO3, -40 °C ≤ T _J ≤ 125 °C switching off-time		1	1.7	mA
I _{VIN,ON}	Operating current	V _{IN} = 16 V, PWMI high, f _{SW} = 200 kHz, C _L = 3.3 nF		5	7	
Boost controller						
t _{ON,min}	Minimum switching on-time	Pulse skipping mode		140	180	ns
K _{FSW}	Switching frequency constant	R _{FSW} = 250 kΩ	45	50	55	MHz • kΩ
f _{SW}	Adjustable switching frequency	R _{FSW} = 500 kΩ	90	100	110	kHz
		R _{FSW} = 250 kΩ	180	200	220	
		R _{FSW} = 50 kΩ	900	1000	1100	
	Fixed switching frequency	FSW pin high (LDO3)	500	600	700	
	Synchronization signal frequency capture range	t _{CLK,H} = 250 ns, V _{CLK,L} = 0.8 V, V _{CLK,H} = 3.0 V	100		1000	
	FSW synchronization input high level	f _{CLK} = 100 kHz to 1 MHz, t _{CLK,H} = 250 ns	2.8			V
	FSW synchronization input low level				0.5	
Synchronization input high level pulse width	f _{CLK} = 100 kHz to 1 MHz, V _{CLK,L} = 0.5 V, V _{CLK,H} = 2.8 V	250			ns	
R _{GATE}	Power switch gate driver output resistance	Pull-up		3	6	Ω
		Pull-down		1	3	
t _{r,GATE}	Power switch gate driver rise time (20 to 80%)	V _{VDR} = 5 V, C _L = 3.3 nF		15	30	ns
t _{f,GATE}	Power switch gate driver fall time (80 to 20%)			7	14	
t _{SS}	Internal soft-start duration		2.9	3.5	4.5	ms
K _S	Slope compensation constant		3	5	7	A/s
V _{CSNS, OCP}	Power switch OCP detection threshold	CSNS pin to PGND	300	360	400	mV

Table 6. Electrical characteristics (continued)

Symbol	Parameter	Conditions	Min.	Typ.	Max.	Unit
Output current sensing section						
V_{FB}	Feedback voltage ($V_{VFBP} - V_{VFBN}$ differential current sensing voltage)	$V_{ADIM} = 0.3 \text{ V}$	20	30	40	mV
		$V_{ADIM} = 0.6 \text{ V}$	110	120	130	
		$V_{ADIM} = 1.2 \text{ V}$	280	300	304	
	Feedback reference voltage accuracy	V_{ADIM} to LDO3	288	300	308	
$V_{ADIM,OFF}$	ADIM pin voltage turn off threshold		260	270	280	
	ADIM pin voltage turn off hysteresis		5	10	20	
I_{VFBP}	Feedback positive input current	$V_{VFBP} = 12.0 \text{ V}$ $V_{VFBN} = 11.7 \text{ V}$	-32	-25	-18	μA
I_{VFBN}	Feedback negative input current	$V_{VFBP} = 12.0 \text{ V}$ $V_{VFBN} = 11.7 \text{ V}$	-7	-5	-4	
PWM dimming control						
R_{PWMO}	PWMO gate driver output resistance	Pull-up		14	22	Ω
		Pull-down		3	8	
$t_{r,PWMO}$	PWMO gate driver rise time (20 to 80%)	$V_{VDR} = 5 \text{ V}$, $C_L = 3.3 \text{ nF}$		50	120	ns
$t_{f,PWMO}$	PWMO gate driver fall time (80 to 20%)			30	60	
Fault management section						
$V_{OVFB,th}$	XFAULT output low level	$I_{XFAULT} = 4 \text{ mA}$		0.12	0.2	V
	XFAULT high level leakage current	$V_{XFAULT} = 5 \text{ V}$		1	4	μA
	OVFB input overvoltage detection threshold		1.14	1.20	1.25	V
	OVFB input overvoltage detection hysteresis		70	100	130	mV
	OVFB pull-up current	$V_{OVFB} = 1 \text{ V}$	0.7	1	1.2	μA
	Open load/VFBP pin disconnection detection threshold (differential)	$(V_{VFBP} - V_{VFBN})$	-190	-120	-80	mV
	Overload /VFBN pin disconnection detection threshold (differential)		550	600	650	
	VFBx undervoltage detection threshold	V_{VFBx} respect to SGND	3.0	3.5	4.0	V

7 Device description

The LED6001 device is a LED driver that integrates a boost controller, a high-side current sensing circuitry and a gate driver for an external dimming switch. It has been specifically designed for driving a single string of high-brightness LEDs. The device can support boost, floating buck-boost and SEPIC topologies in order to cover most of applications. A single pin, PWMI, combines both the device enable and PWM dimming control functions.

The brightness of the LED string can be controlled through PWM modulation, analog control of the output current level (by means of a dedicated pin) or a combination of the two.

7.1 Device supply

The LED6001 device integrates two low dropout linear regulators to derive the + 3.3 V (typ.) main supply and the +5 V supply for the gate drivers. The VIN pin is the input terminal for both linear regulators. Both the linear regulators are enabled when a PWM signal is applied to the PWMI pin. If the PWMI pin is held low for more than 10 ms (min.), the shutdown mode is automatically entered and both the LDOs are turned-off for minimum power consumption. An undervoltage lockout (UVLO) protection is associated to each linear regulator: in case the output voltage of LDO3 and VDR is below their respective nominal value, the device is no allowed to operate and the XFAULT pin is tied low.

When an external +5 V rail is available, the related internal LDO can be bypassed by connecting together the VIN and VDR pins: in this case the VDR pin is used as supply input.

7.2 Boost controller

7.2.1 Turn on and power-down sequences

The LED6001 is turned on and off by acting on the PWMI pin. This digital input combines two functions at the same time: device turn on/off and PWM dimming control.

When a high pulse having a 100 μ s (typ.) minimum duration appears at the PWMI pin, the LDOs are turned on and, after the VDR has reached its nominal value, a soft-start sequence on the boost controller takes place. The output voltage is smoothly increased by releasing in steps the current limit of the boost converter within a fixed 3 ms (typ.) period, unless the feedback voltage reaches 75% of the nominal value in advance.

Figure 4. Turn on and turn off waveforms

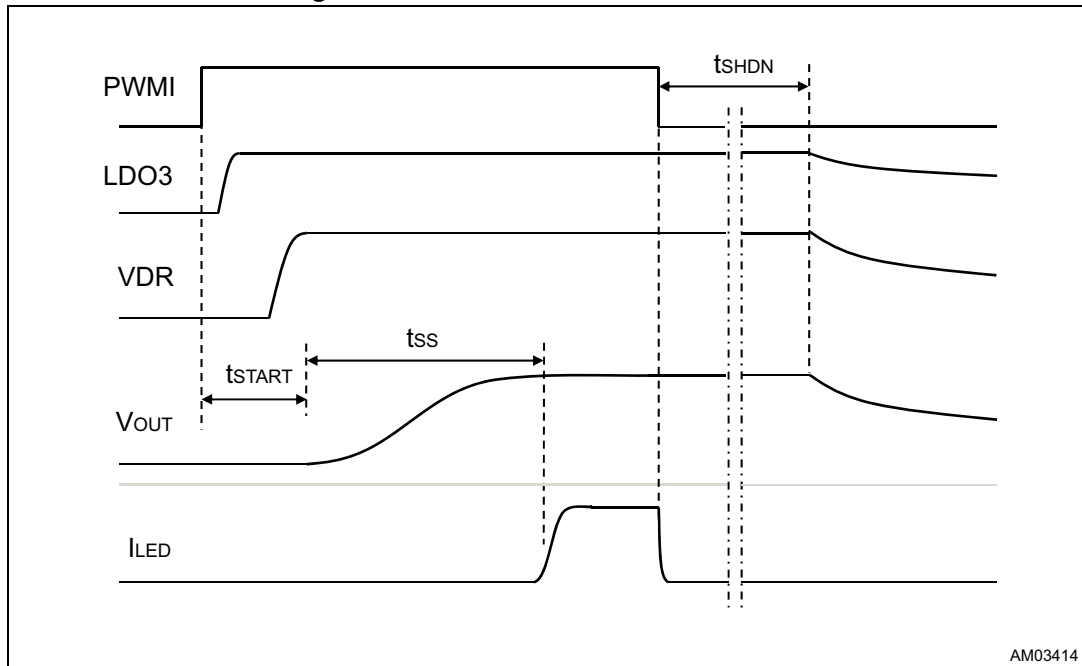

Suddenly after the pulse detection at the PWMI pin, an internal timer is enabled and cleared. The timer starts counting down on every subsequent falling edge. If the PWMI pin is held low for more than 10 ms (typ.), the timer is allowed to expire and the LED6001 automatically turns off minimizing the current consumption.

The start-up time, defined as the delay between the rising edge at the PWMI pin and the first pulse at the GATE pin, clearly depends on the bypass capacitors connected on both LDO3 and VDR pins. With a typical 1 μ F MLCC for both pins, the start-up time is in the order of 100 μ s.

7.2.2 Boost controller operation

The boost controller of the LED6001 device is based on peak current mode control architecture and can easily support boost, floating buck-boost and SEPIC topologies. The switching frequency of the converter is set through the FSW pin (external clock source or setting resistor toward ground) while the switching duty cycle is modulated by the control loop in order to keep the output (LED) current constant. As a consequence, the output voltage of the boost converter is determined by the LED string.

Figure 5. Simplified output regulation circuitry

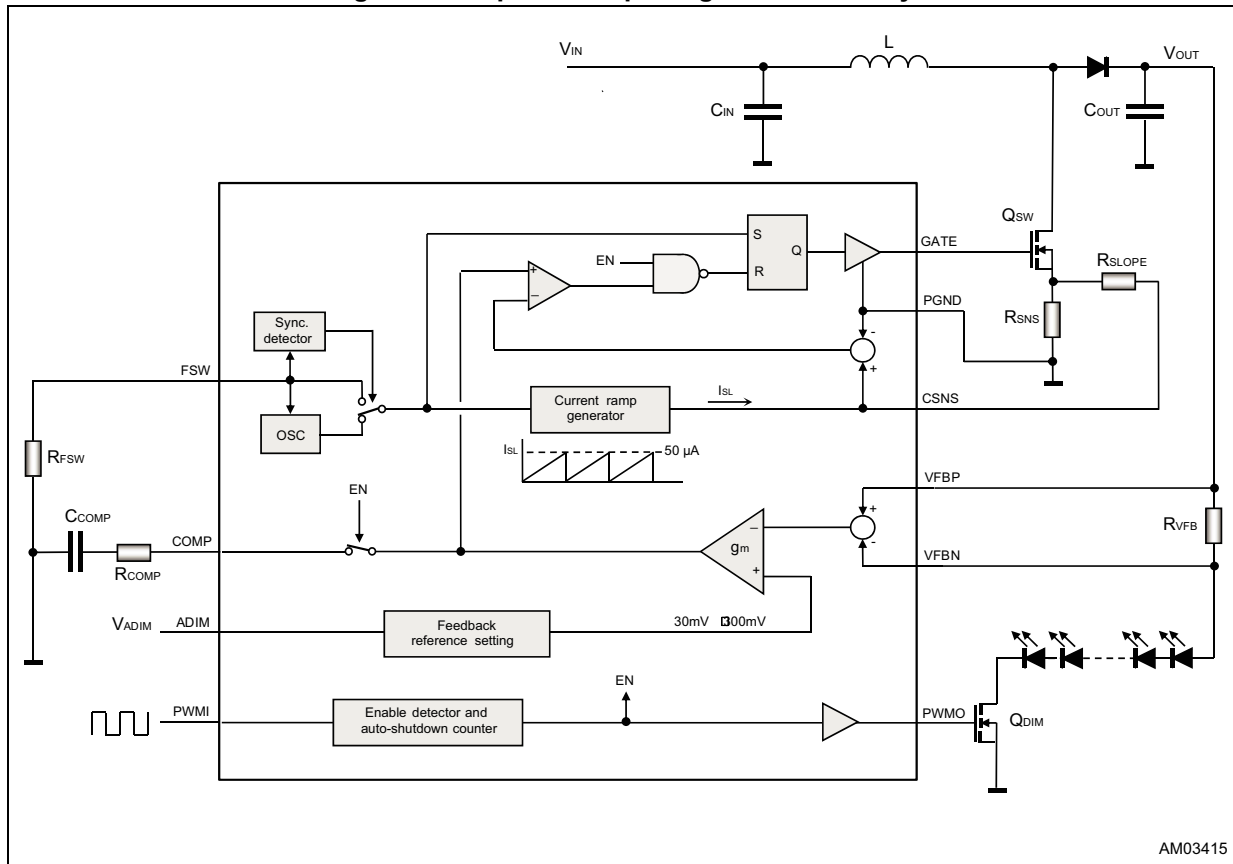

The boost controller regulates the output (LED) current by measuring the voltage across the external sensing resistor. The internal circuitry related to the two pins connected to the sensing resistor (VFBP and VFBN) has been designed to implement a high-side sensing scheme and can sustain a relatively high voltage. The voltage drop across the sensing resistor is the actual feedback voltage for the boost regulator control loop and it can be linearly varied by means of the ADIM pin (see [Section 7.3: LED current regulation and brightness control on page 17](#) for details).

The COMP pin is the output of the transconductance amplifier involved in the regulation loop and a simple RC series must be connected between this pin and SGND to ensure proper loop stability.

7.2.3 Boost converter stability and slope compensation

As visible in [Figure 5](#), the difference between the feedback voltage and the programmed is converted into an error current by the transconductance amplifier. This current, provided at the COMP pin, is turned into a voltage across the compensation network externally connected to the same pin. This voltage, in turn, determines the trip current for the following error amplifier.

When the boost converter operates in continuous conduction mode (CCM) and the switching duty cycle is higher than 50%, sub-harmonic instability may occur.

In order to prevent this, the trip current has to be properly shaped by summing a negative sawtooth ramp voltage (slope compensation) with the amplified error voltage.

In LED6001 the slope compensation is achieved by injecting a sawtooth current into the CSNS pin. Therefore the voltage across the CSNS pin is given by:

Equation 1

$$V_{CSNS}(t) = i_{MOS}(t) \cdot R_{SHUNT} + i_{SL}(t) \cdot R_{CSNS}$$

The R_{SNS} resistor is usually designed so that the peak voltage is about 15% of the overcurrent threshold at the CSNS pin in order to have a good S/N ratio, while the R_{SLOPE} resistor is calculated for the desired slope compensation amount (typically at least half the downslope of the inductor current during the switching off-time):

Equation 2

$$R_{SNS} \cong \frac{50mV}{I_{L,PEAK}}$$

Equation 3

$$R_{SLOPE} \geq \frac{V_{OUT} - V_{IN,min}}{f_{SW} \cdot L} \cdot \frac{R_{SNS}}{I_{SL}}$$

Where $I_{SL} = 50 \mu A$ is the maximum current injected by the slope compensation circuitry in the CSNS pin.

Figure 6. Power switch current sensing scheme

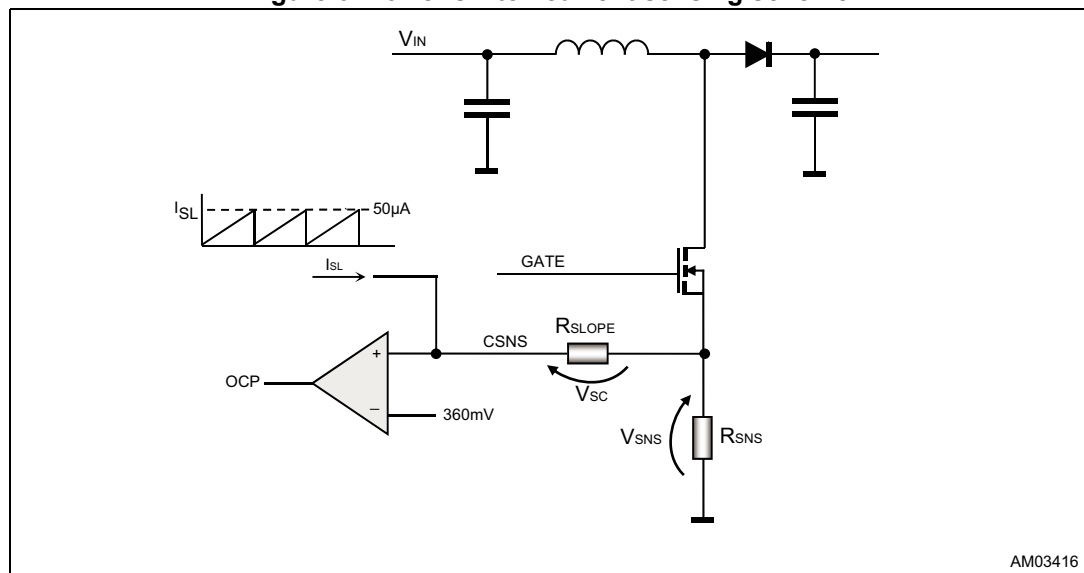

7.2.4 Switching frequency oscillator and external synchronization

The switching frequency of the boost controller is simply set by connecting a resistor between the FSW pin and ground. The resistor can be calculated according to [Equation 4](#):

Equation 4

$$R = \frac{K_{FSW}}{f_{SW}}$$

Where $K_{FSW} = 5 \cdot 10^{10} \text{ Hz} \cdot \Omega$ (typ.) and $100 \text{ kHz} \leq f_{SW} \leq 1 \text{ MHz}$.

Figure 7. Switching frequency vs. setting resistor at the FSW pin

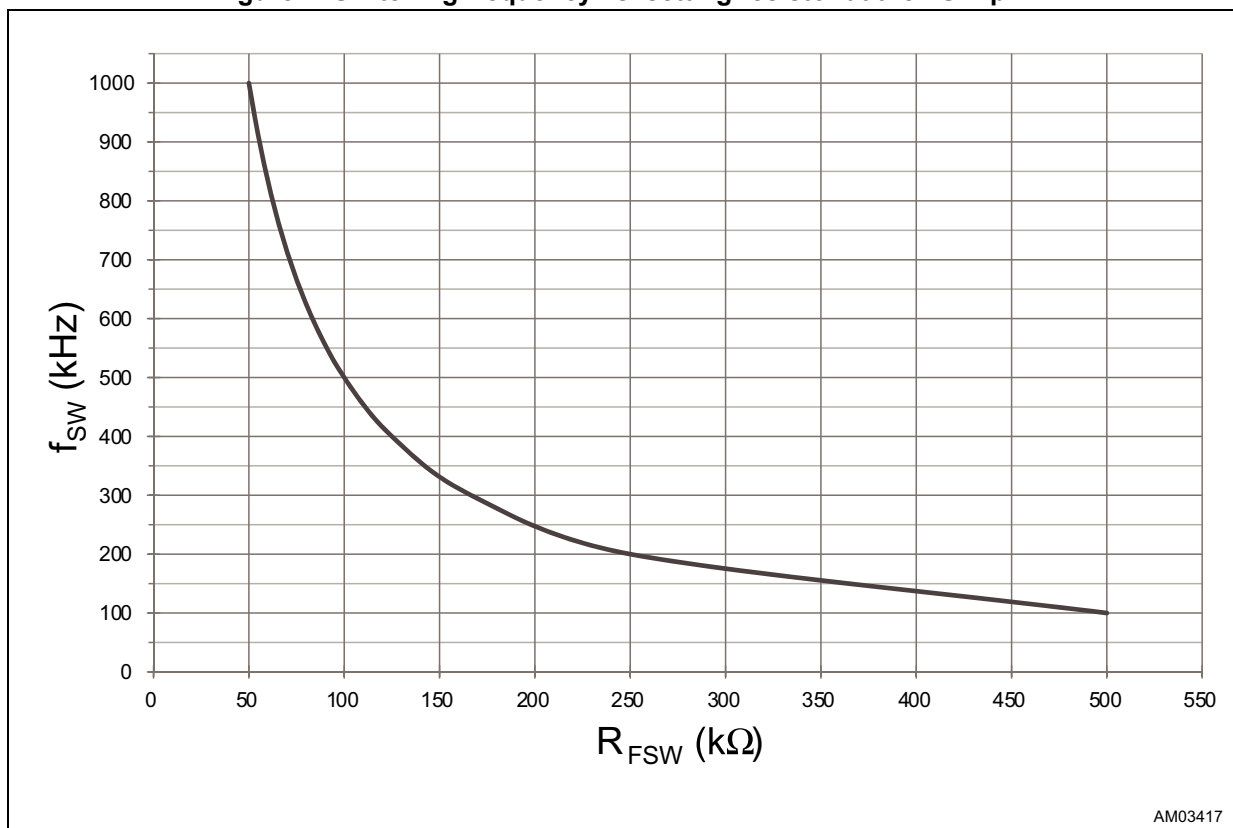

AM03417

If the FSW pin is tied high (e.g. connecting it to LDO3), a 600 kHz (typ.) default switching frequency is set.

In case the boost controller of the LED6001 has to be externally synchronized, the FSW pin can be used as synchronization clock input. In this case the external clock must have a frequency in the 100 kHz - 1 MHz range and a 250 ns minimum pulse duration in order to ensure internal oscillator locking.

Figure 8. External synchronization signal timing diagram

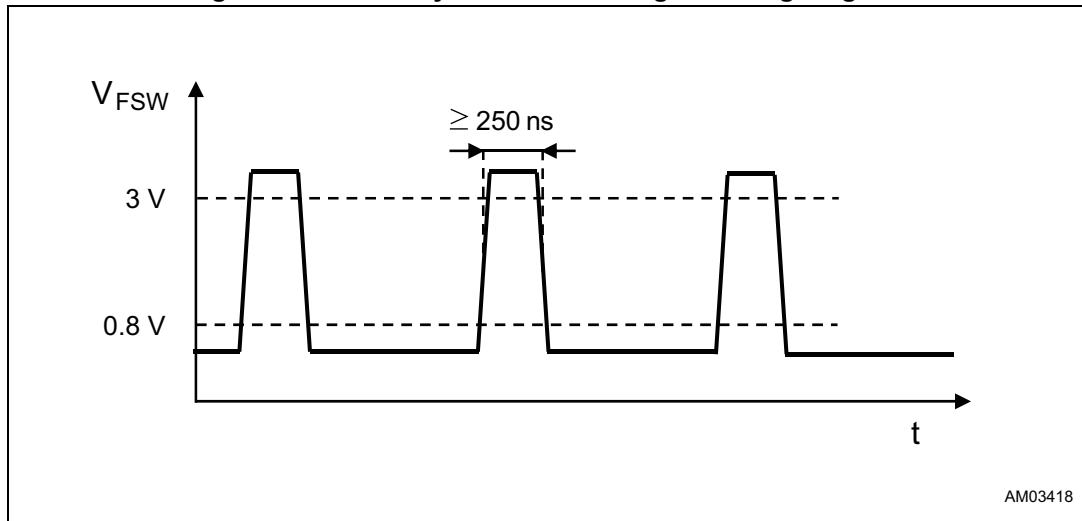

7.3 LED current regulation and brightness control

The brightness of the LEDs connected at the output of the LED6001 can be controlled by applying the desired PWM signal at the PWMI pin. The boost controller is turned on and off according to the duty cycle of the PWMI control signal. When the PWMI is high (and the soft-start has been completed), the output (LED) current is regulated by keeping constant the voltage drop across the external sensing resistor connected between the VFBN and VFBN pins.

A buffered replica of PWMI is available at the PWMO for driving a dimming N-channel MOSFET when superior dimming performance is required. In some applications a high-side dimming switch could be desirable (e.g.: protection against output short-circuit to ground or LED strings using the chassis as return) and a P-channel MOSFET can be used as shown in [Figure 9](#). Some additional components may be needed to avoid excessive voltage between the gate and the source of such MOSFET.

Figure 9. High-side dimming control by using a P-channel MOSFET

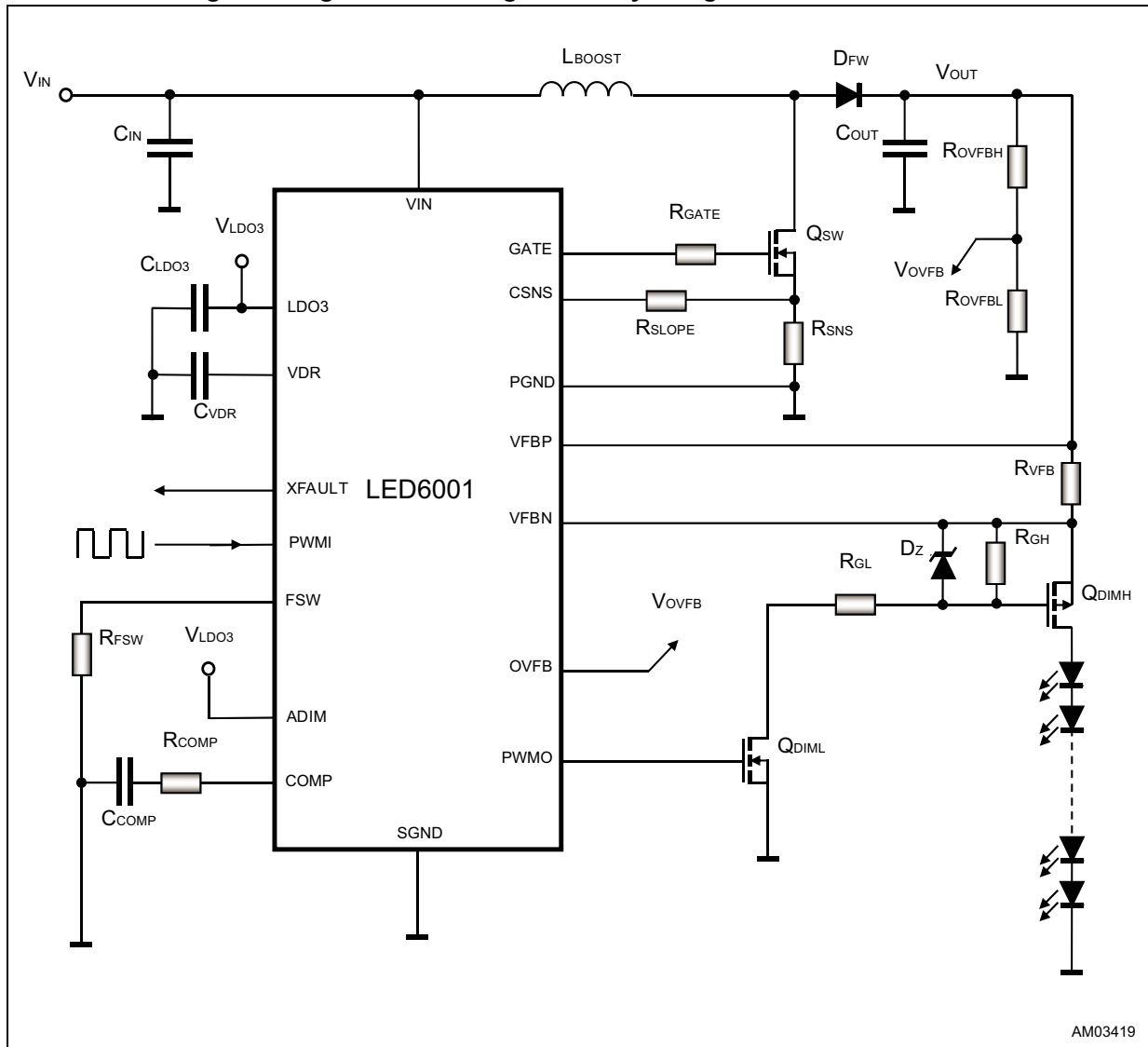

The regulation loop continuously compares the differential voltage drop with an internal reference and adjusts the switching duty cycle accordingly. In order to provide design flexibility and analog dimming capability, the internal feedback reference can be changed through the ADIM pin. As visible in [Figure 10](#), the reference voltage is proportional to the voltage at the ADIM pin within a limited range.

Equation 5

$$I_{LED} = \begin{cases} 0 & \text{if } V_{ADIM} < 260mV \\ \frac{0.3 \cdot (V_{ADIM} - 200mV)}{R_{VFB}} & \text{if } 300mV \leq V_{ADIM} \leq 1.2V \\ \frac{300mV}{R_{VFB}} & \text{if } V_{ADIM} > 1.2V \end{cases}$$

Figure 10. Differential feedback reference voltage vs. ADIM pin voltage

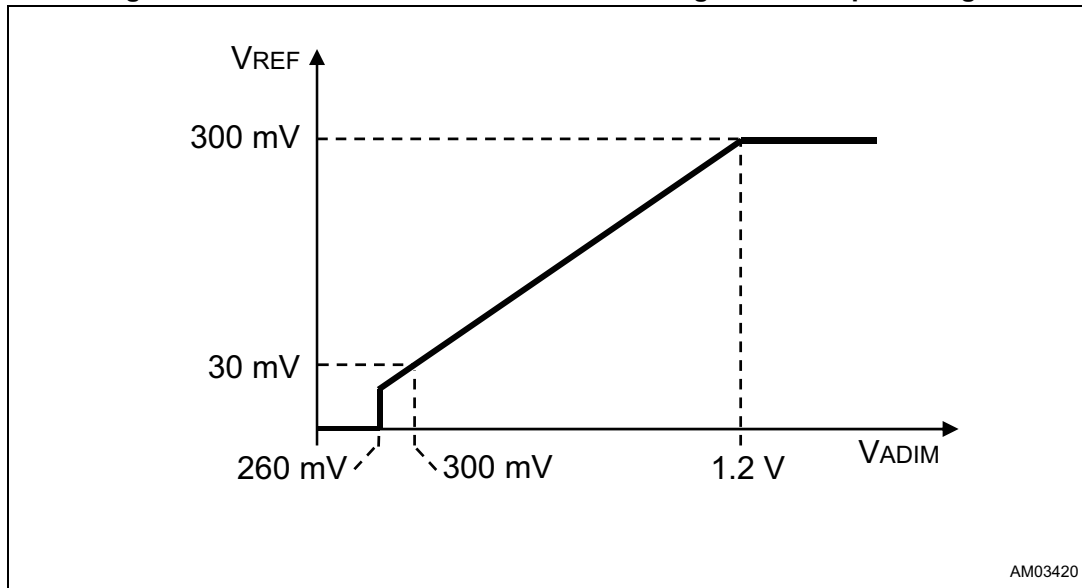

In case a fixed output (LED) current is needed or simple PWM dimming is used, the ADIM pin must be connected to the central tap of a resistor divider (supplied by the LDO3 pin) for the desired LED current level. Because of the best LED current accuracy overtime, a voltage higher than 1.2 V should be applied at the ADIM pin in case the analog dimming is not needed.

If an analog dimming control is required, the voltage at the ADIM pin can be changed runtime within its functional range. A simple way to perform an analog dimming is easily achieved by extracting the average value of a PWM signal through a simple RC low-pass filter (Figure 10).

Figure 11. Simple ADIM pin voltage control through a filtered PWM signal

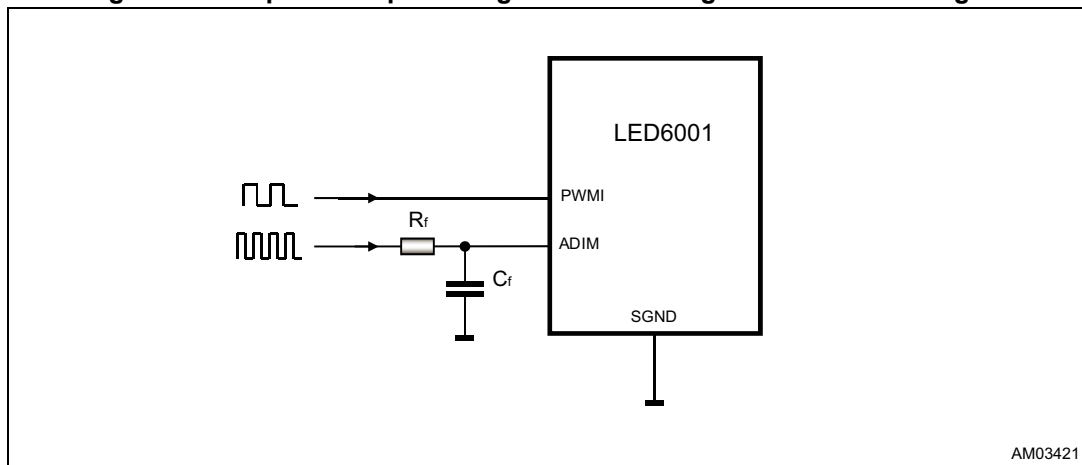

If the voltage at the ADIM pin is lower than 260 mV, both the PWMO and GATE pins are forced low and the boost converter is temporary disabled. As soon as the ADIM pin voltage is driven inside the operating range, normal operation is resumed.

7.4 Device protections

7.4.1 Linear regulators undervoltage lockout

Both the 5 V and 3.3 V linear regulators of the LED6001 are equipped with an undervoltage lockout (UVLO) protection. The UVLO protections avoid improper device operation in case at least one of the two outputs (VDR and LDO3) is below the allowed level. In particular, the LED6001 performs the soft-start sequence only after both VDR and LDO3 cross their respective upper UVLO threshold.

7.4.2 Power switch overcurrent

The current flowing through the external power MOSFET is monitored, cycle-by-cycle, by sensing the voltage across the shunt resistor in series with its source. If the voltage drop exceeds the overcurrent protection (OCP) level, the ongoing switching cycle is suddenly terminated (cycle-by-cycle power MOSFET OCP). Normal operation is automatically resumed once the root cause has been removed. The XFAULT pin is not affected by OCP.

As explained in [Section 7.2 on page 12](#) the slope compensation is added by injecting a sawtooth current at the CSNS pin. As a consequence, the OCP threshold depends on both the slope compensation amount and the boost converter's operating point:

Equation 6

$$I_{MOS, OCP} = \frac{V_{CSNS, OCP} - D \cdot I_{SL} \cdot R_{SLOPE}}{R_{SNS}}$$

Where $V_{CSNS, OCP} = 360$ mV (typ.), $I_{SL} = 50$ μ A (typ.) and D is the switching duty cycle.

7.4.3 Output overvoltage and OVFB pin disconnection

The output overvoltage fault detection is achieved by comparing the voltage at the OVFB pin with an internal threshold. Because of this fault can potentially damage both the device and the external components, a latched turn off condition is triggered once this event has been detected. A resistor divider connected to the output of the boost converter sets the desired OVP threshold.

The OVFB is internally pulled-up in order to protect the device against an OVFB pin disconnection fault: if the pin is left floating, the OVP is suddenly triggered regardless of the output voltage level. This small pull-up current ($I_{OVFB, PU}$) must be taken into account when designing an OVP output divider involving high resistance values. [Equation 7](#) allows setting the desired output OVP level (R_{OVPH} and R_{OVPL} are the two resistors of the output divider whose central tap is connected to the OVFB pin of LED6001):

Equation 7

$$V_{OUT, OVP} = \frac{R_{OVPH} + R_{OVPL}}{R_{OVPL}} V_{TH, OVFB} - R_{OVPL} \cdot I_{OVFB, PU}$$

Where $V_{TH, OVFB} = 1.2$ V (typ.) and $I_{OVFB, PU} = 1$ μ A (typ.).

Once the OVP faulty condition is detected, the LED6001 device suddenly stops switching. Both GATE and PWMO are forced low and the XFAULT pin is lowered. The condition is

latched and normal operation is resumed by toggling the PWMI pin (PWMI has to be low for more than 10 ms) after the root cause has been removed.

7.4.4 Output rail disconnection detection or output short-circuit to ground

If the connection between the output rail and the output sensing resistor is lost, the voltage of both the VFBP and VFBN pins falls down to zero. The LED6001 detects this faulty condition by comparing the absolute voltage of both VFBP and VFBN pins with an internal 3.3 V threshold and latches-off as a consequence (the GATE and PWMO pins forced low, XFAULT pin lowered). Normal operation is resumed by toggling the PWMI pin (PWMI has to be low for more than 10 ms) after the root cause has been removed.

When the LED6001 is operating with a boost topology, a similar condition occurs in case of output-to-ground short-circuit. Of course, because of the inherent path between input and output, a real protection against this faulty condition can be achieved only if the device is capable of disconnecting the boost output by means of the dimming switch (e.g. in case a P-channel MOSFET is used as a high-side dimming switch).

Figure 12. Load disconnection (1 and 5), open feedback (2 and 3) and open OVFB faulty conditions

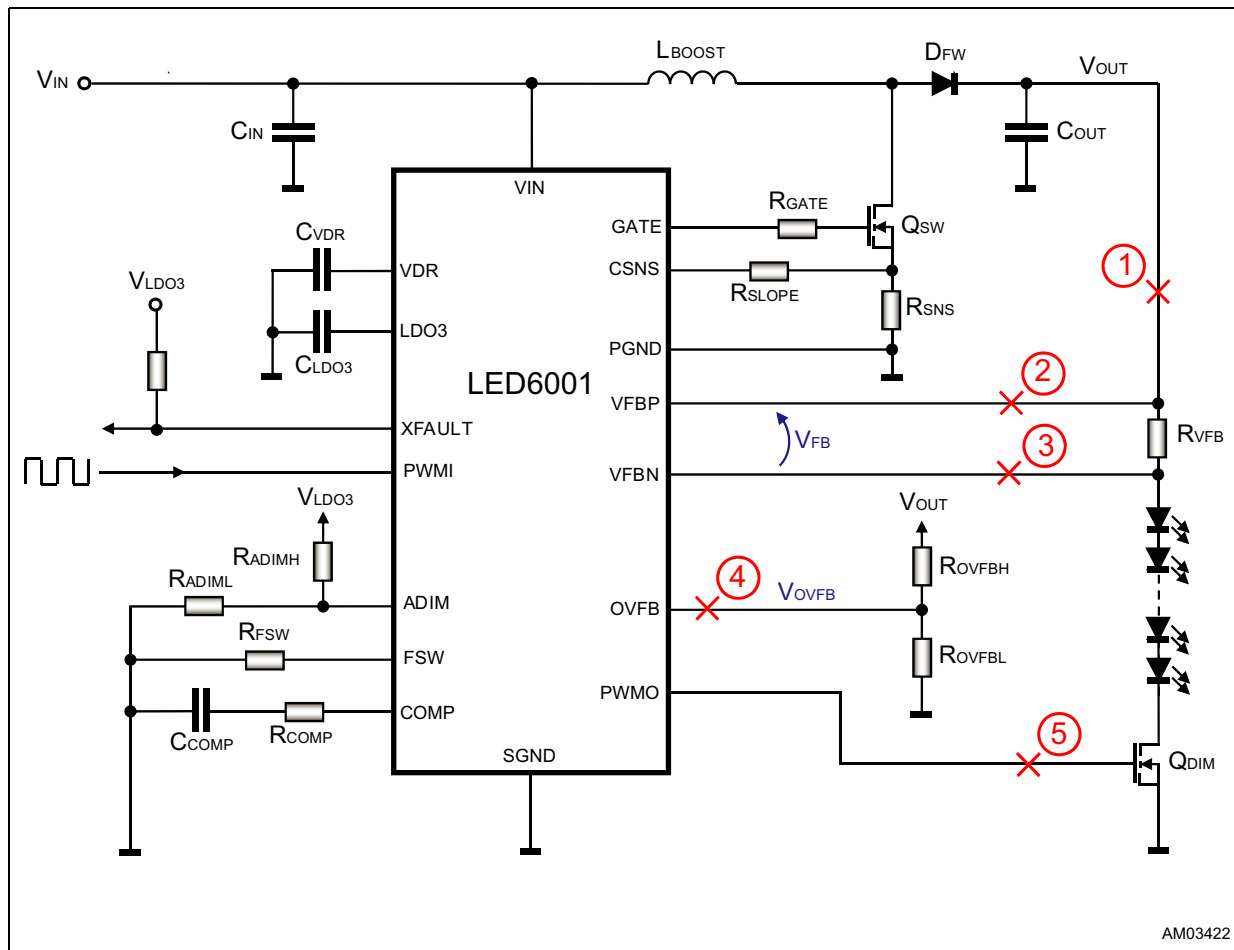

7.4.5 Thermal shutdown

The LED6001 implements an autoresetting thermal protection in order to avoid damages due to excessive die temperature. Once the chip temperature reaches the upper overtemperature protection (OTP) threshold, the ongoing operation is suddenly stopped, both the PWMO and XFAULT pins are held low and the 5 V linear regulator (VDR pin) is turned off. As soon as the die temperature drops below the autoresetting threshold, a new soft-start sequence takes place if the PWMI pin is still high and a 1 ms (typ.) deglitch delay has expired.

The XFAULT pin goes low as soon as the OTP threshold is crossed and it is released once the device temperature drops below a third threshold, lower than the restart one, in order to provide a stable information to the host system.

Table 7. Faulty conditions management summary

Faulty condition		Detection mechanism	Consequence
1	Output rail/load disconnection	$V_{VFBx} < 3.5 \text{ V}$	Device turning-off (latched condition). GATE, PWMO and XFAULT pins are forced low.
2	Open feedback (VFBP)	$V_{VFBP} - V_{VFBN} < -120 \text{ mV}$	
3	Open feedback (VFBN)	$V_{VFBP} - V_{VFBN} > 600 \text{ mV}$	
	LED overcurrent		
	Output to GND short-circuit⁽¹⁾		
4	Open OVFB path	$V_{OVFB} > 1.2 \text{ V}$ (internal pull-up)	
5	Open PWMO (loss of dimming MOSFET control)	$V_{OVFB} > 1.2 \text{ V}$	
Output overvoltage			
Power switch overcurrent		$V_{CSNS} > 360 \text{ mV}$	Ongoing switching cycle terminated
IC overtemperature		$T_J > 160 \text{ }^\circ\text{C}$ (typ.)	Device turning-off (VDR off, LDO3 active). GATE, PWMO and XFAULT pins are forced low. Autorestart if $T_J < 140 \text{ }^\circ\text{C}$ (typ.) and PWMI still high. XFAULT pin is released if $T_J < 120 \text{ }^\circ\text{C}$ (typ.).

1. Output-to-ground short-circuit protection can be achieved only if the device can effectively disconnect the output by acting on the PWMO pin (e.g. a high-side P-channel MOSFET is used as a dimming switch).

8 Package information

In order to meet environmental requirements, ST offers these devices in different grades of ECOPACK® packages, depending on their level of environmental compliance. ECOPACK specifications, grade definitions and product status are available at: www.st.com. ECOPACK is an ST trademark.

Figure 13. HTSSOP-16 package outline

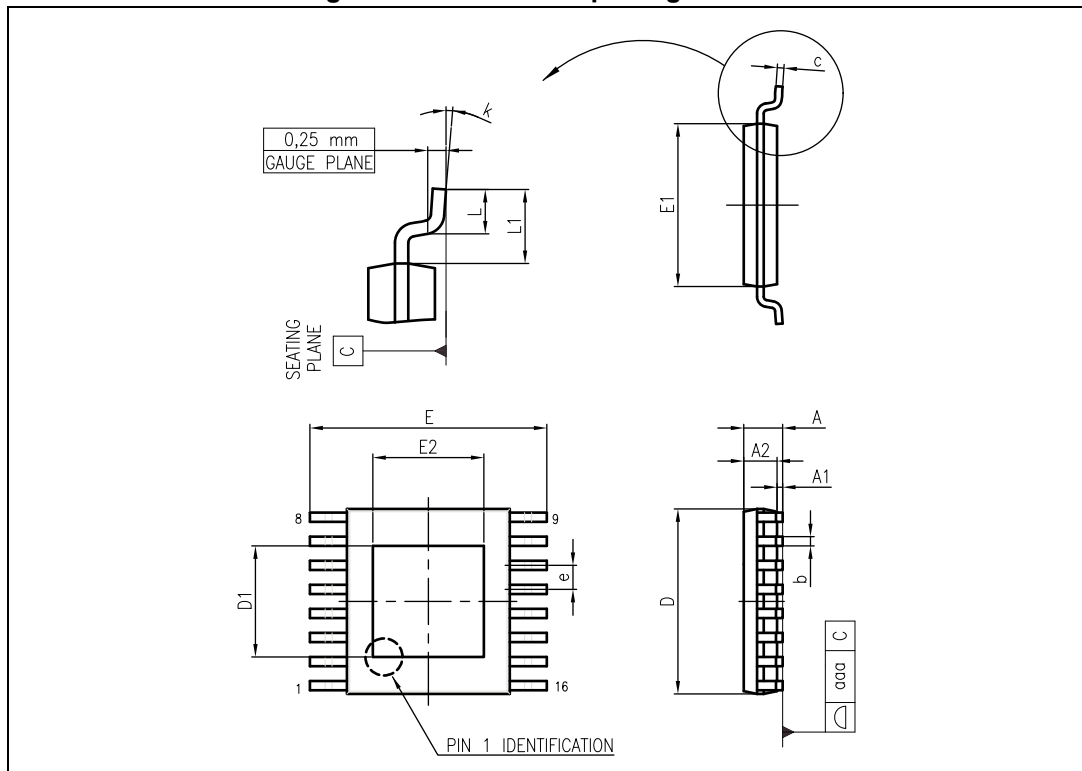

Table 8. HTSSOP-16 package mechanical data⁽¹⁾

Symbol	Dimensions (mm)			Note
	Min.	Typ.	Max.	
A			1.20	
A1			0.15	
A2	0.80	1.00	1.05	
b	0.19		0.30	
c	0.09		0.20	
D	4.90	5.00	5.10	(2)
D1		3.00		(3)
E	6.20	6.40	6.60	
E1	4.30	4.40	4.50	(4)
E2		3.00		(3)
e		0.65		
L	0.45	0.60	0.75	
L1		1.00		
k	0.00		8.00	
aaa			0.10	

1. HTSSOP stands for "Thermally Enhanced Variations".
2. Dimension "D" does not include mold flash, protrusions or gate burrs. Mold flash, protrusions or gate burrs shall not exceed 0.15 mm per side.
3. The size of exposed pad is variable depending of leadframe design pad size. End user should verify "D1" and "E2" dimensions for each device application.
4. Dimension "E1" does not include interlead flash or protrusions. Interlead flash or protrusions shall not exceed 0.25 mm per side.

9 Revision history

Table 9. Document revision history

Date	Revision	Changes
22-Nov-2013	1	Initial release.
13-Feb-2014	2	Updated <i>Figure 2: Pin connection (through top view) on page 4</i> (renumbered CSNS pin from 8 to 9, switched names of PWMO and CSNS pins).
26-Jun-2014	3	Updated <i>Section : Applications on page 1</i> (replaced by new applications). Minor modifications throughout document.

Please Read Carefully:

Information in this document is provided solely in connection with ST products. STMicroelectronics NV and its subsidiaries ("ST") reserve the right to make changes, corrections, modifications or improvements, to this document, and the products and services described herein at any time, without notice.

All ST products are sold pursuant to ST's terms and conditions of sale.

Purchasers are solely responsible for the choice, selection and use of the ST products and services described herein, and ST assumes no liability whatsoever relating to the choice, selection or use of the ST products and services described herein.

No license, express or implied, by estoppel or otherwise, to any intellectual property rights is granted under this document. If any part of this document refers to any third party products or services it shall not be deemed a license grant by ST for the use of such third party products or services, or any intellectual property contained therein or considered as a warranty covering the use in any manner whatsoever of such third party products or services or any intellectual property contained therein.

UNLESS OTHERWISE SET FORTH IN ST'S TERMS AND CONDITIONS OF SALE ST DISCLAIMS ANY EXPRESS OR IMPLIED WARRANTY WITH RESPECT TO THE USE AND/OR SALE OF ST PRODUCTS INCLUDING WITHOUT LIMITATION IMPLIED WARRANTIES OF MERCHANTABILITY, FITNESS FOR A PARTICULAR PURPOSE (AND THEIR EQUIVALENTS UNDER THE LAWS OF ANY JURISDICTION), OR INFRINGEMENT OF ANY PATENT, COPYRIGHT OR OTHER INTELLECTUAL PROPERTY RIGHT.

ST PRODUCTS ARE NOT DESIGNED OR AUTHORIZED FOR USE IN: (A) SAFETY CRITICAL APPLICATIONS SUCH AS LIFE SUPPORTING, ACTIVE IMPLANTED DEVICES OR SYSTEMS WITH PRODUCT FUNCTIONAL SAFETY REQUIREMENTS; (B) AERONAUTIC APPLICATIONS; (C) AUTOMOTIVE APPLICATIONS OR ENVIRONMENTS, AND/OR (D) AEROSPACE APPLICATIONS OR ENVIRONMENTS. WHERE ST PRODUCTS ARE NOT DESIGNED FOR SUCH USE, THE PURCHASER SHALL USE PRODUCTS AT PURCHASER'S SOLE RISK, EVEN IF ST HAS BEEN INFORMED IN WRITING OF SUCH USAGE, UNLESS A PRODUCT IS EXPRESSLY DESIGNATED BY ST AS BEING INTENDED FOR "AUTOMOTIVE, AUTOMOTIVE SAFETY OR MEDICAL" INDUSTRY DOMAINS ACCORDING TO ST PRODUCT DESIGN SPECIFICATIONS. PRODUCTS FORMALLY ESCC, QML OR JAN QUALIFIED ARE DEEMED SUITABLE FOR USE IN AEROSPACE BY THE CORRESPONDING GOVERNMENTAL AGENCY.

Resale of ST products with provisions different from the statements and/or technical features set forth in this document shall immediately void any warranty granted by ST for the ST product or service described herein and shall not create or extend in any manner whatsoever, any liability of ST.

ST and the ST logo are trademarks or registered trademarks of ST in various countries.

Information in this document supersedes and replaces all information previously supplied.

The ST logo is a registered trademark of STMicroelectronics. All other names are the property of their respective owners.

© 2014 STMicroelectronics - All rights reserved

STMicroelectronics group of companies

Australia - Belgium - Brazil - Canada - China - Czech Republic - Finland - France - Germany - Hong Kong - India - Israel - Italy - Japan - Malaysia - Malta - Morocco - Philippines - Singapore - Spain - Sweden - Switzerland - United Kingdom - United States of America

www.st.com

Looking for pricing, stock, or lifecycle information?

Click below to explore more details on WIN SOURCE:

-  [View LED6001TR](#) on WIN SOURCE
-  [STMicroelectronics](#) Information

Optimize Your Supply Chain with WIN SOURCE Solutions

-  Global Sourcing Solution
-  Obsolete Management
-  Cost Control Management
-  Shortage Management
-  Alternative Solution
-  Excess Inventory Management