



**THE DATASHEET OF  
NCV33039DR2G**



# MC33039, NCV33039

## Closed Loop Brushless Motor Adapter

The MC33039 is a high performance closed-loop speed control adapter specifically designed for use in brushless DC motor control systems. Implementation will allow precise speed regulation without the need for a magnetic or optical tachometer. This device contains three input buffers each with hysteresis for noise immunity, three digital edge detectors, a programmable monostable, and an internal shunt regulator. Also included is an inverter output for use in systems that require conversion of sensor phasing. Although this device is primarily intended for use with the MC33035 brushless motor controller, it can be used cost effectively in many other closed-loop speed control applications.

### Features

- Digital Detection of Each Input Transition for Improved Low Speed Motor Operation
- TTL Compatible Inputs With Hysteresis
- Operation Down to 5.5 V for Direct Powering from MC33035 Reference
- Internal Shunt Regulator Allows Operation from a Non-Regulated Voltage Source
- Inverter Output for Easy Conversion between 60°/300° and 120°/240° Sensor Phasing Conventions
- Pb-Free Packages are Available

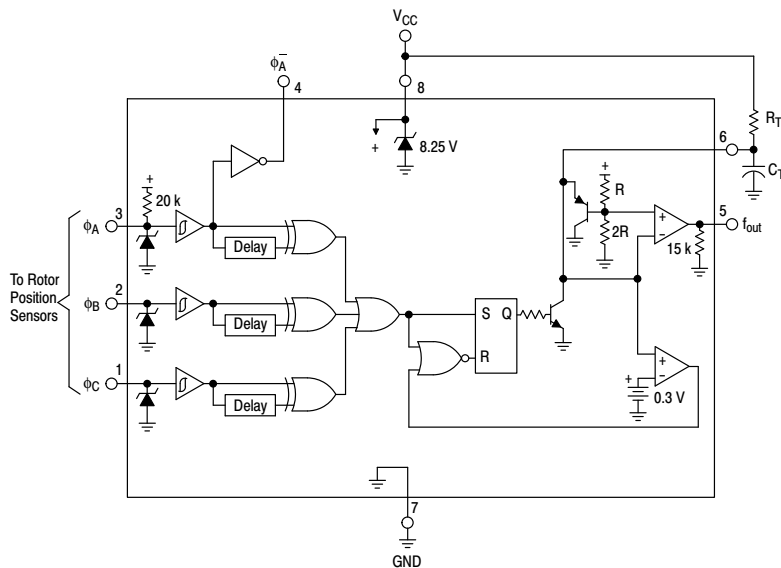

Representative Block Diagram



ON Semiconductor®

<http://onsemi.com>

### MARKING DIAGRAMS

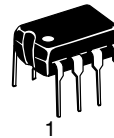

PDIP-8  
P SUFFIX  
CASE 626

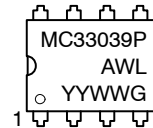

SOIC-8  
D SUFFIX  
CASE 751

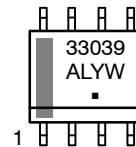

A = Assembly Location  
WL, L = Wafer Lot  
YY, Y = Year  
WW, W = Work Week  
G or ■ = Pb-Free Package

### PIN CONNECTIONS

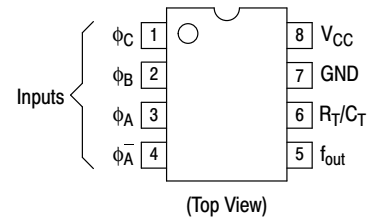

### ORDERING INFORMATION

See detailed ordering and shipping information in the package dimensions section on page 6 of this data sheet.

# MC33039, NCV33039

## MAXIMUM RATINGS

Rating	Symbol	Value	Unit
V <sub>CC</sub> Zener Current	I <sub>Z</sub> (V <sub>CC</sub> )	30	mA
Logic Input Current (Pins 1, 2, 3)	I <sub>IH</sub>	5.0	mA
Output Current (Pins 4, 5), Sink or Source	I <sub>DRV</sub>	20	mA
Power Dissipation and Thermal Characteristics Maximum Power Dissipation @ T <sub>A</sub> = +85°C Thermal Resistance, Junction-to-Air	P <sub>D</sub> R <sub>θJA</sub>	650 100	mW °C/W
Operating Junction Temperature	T <sub>J</sub>	+150	°C
Operating Ambient Temperature Range MC33039 NCV33039	T <sub>A</sub>	-40 to +85 -40 to +125	°C
Storage Temperature Range	T <sub>stg</sub>	-65 to +150	°C

Stresses exceeding Maximum Ratings may damage the device. Maximum Ratings are stress ratings only. Functional operation above the Recommended Operating Conditions is not implied. Extended exposure to stresses above the Recommended Operating Conditions may affect device reliability.

## ELECTRICAL CHARACTERISTICS (V<sub>CC</sub> = 6.25 V, R<sub>T</sub> = 10 k, C<sub>T</sub> = 22 nF, T<sub>A</sub> = 25°C, unless otherwise noted)

Characteristic	Symbol	Min	Typ	Max	Unit
----------------	--------	-----	-----	-----	------

### LOGIC INPUTS

Input Threshold Voltage High State	V <sub>IH</sub>	2.4	2.1	-	V
Low State	V <sub>IL</sub>	-	1.4	1.0	
Hysteresis	V <sub>H</sub>	0.4	0.7	0.9	
Input Current High State (V <sub>IH</sub> = 5.0 V)	I <sub>IH</sub>				μA
φ <sub>A</sub>		-40	-60	-80	
φ <sub>B</sub> , φ <sub>C</sub>		-	-0.3	-5.0	
Low State (V <sub>IL</sub> = 0 V)	I <sub>IL</sub>				
φ <sub>A</sub>		-190	-300	-380	
φ <sub>B</sub> , φ <sub>C</sub>		-	-0.3	-5.0	

### MONOSTABLE AND OUTPUT SECTIONS

Output Voltage High State	V <sub>OH</sub>				V
f <sub>out</sub> (I <sub>source</sub> = 5.0 mA)		3.60	3.95	4.20	
φ <sub>A</sub> (I <sub>source</sub> = 2.0 mA)		4.20	4.75	-	
Low State	V <sub>OL</sub>				
f <sub>out</sub> (I <sub>sink</sub> = 10 mA)		-	0.25	0.50	
φ <sub>A</sub> (I <sub>sink</sub> = 10 mA)		-	0.25	0.50	
Capacitor C <sub>T</sub> Discharge Current	I <sub>dischg</sub>	20	35	60	mA
Output Pulse Width (Pin 5)	t <sub>PW</sub>	205	225	245	μs

### POWER SUPPLY SECTION

Power Supply Operating Voltage Range MC33039 (T <sub>A</sub> = -40° to +85°C) NCV33039 (T <sub>A</sub> = -40° to +125°C)	V <sub>CC</sub>	5.5	-	V <sub>Z</sub>	V
Power Supply Current	I <sub>CC</sub>	1.8	3.9	5.0	mA
Zener Voltage (I <sub>Z</sub> = 10 mA)	V <sub>Z</sub>	7.5	8.25	9.0	V
Zener Dynamic Impedance (ΔI <sub>Z</sub> = 10 mA to 20 mA, f ≤ 1.0 kHz)	Z <sub>ka</sub>	-	2.0	5.0	Ω

# MC33039, NCV33039

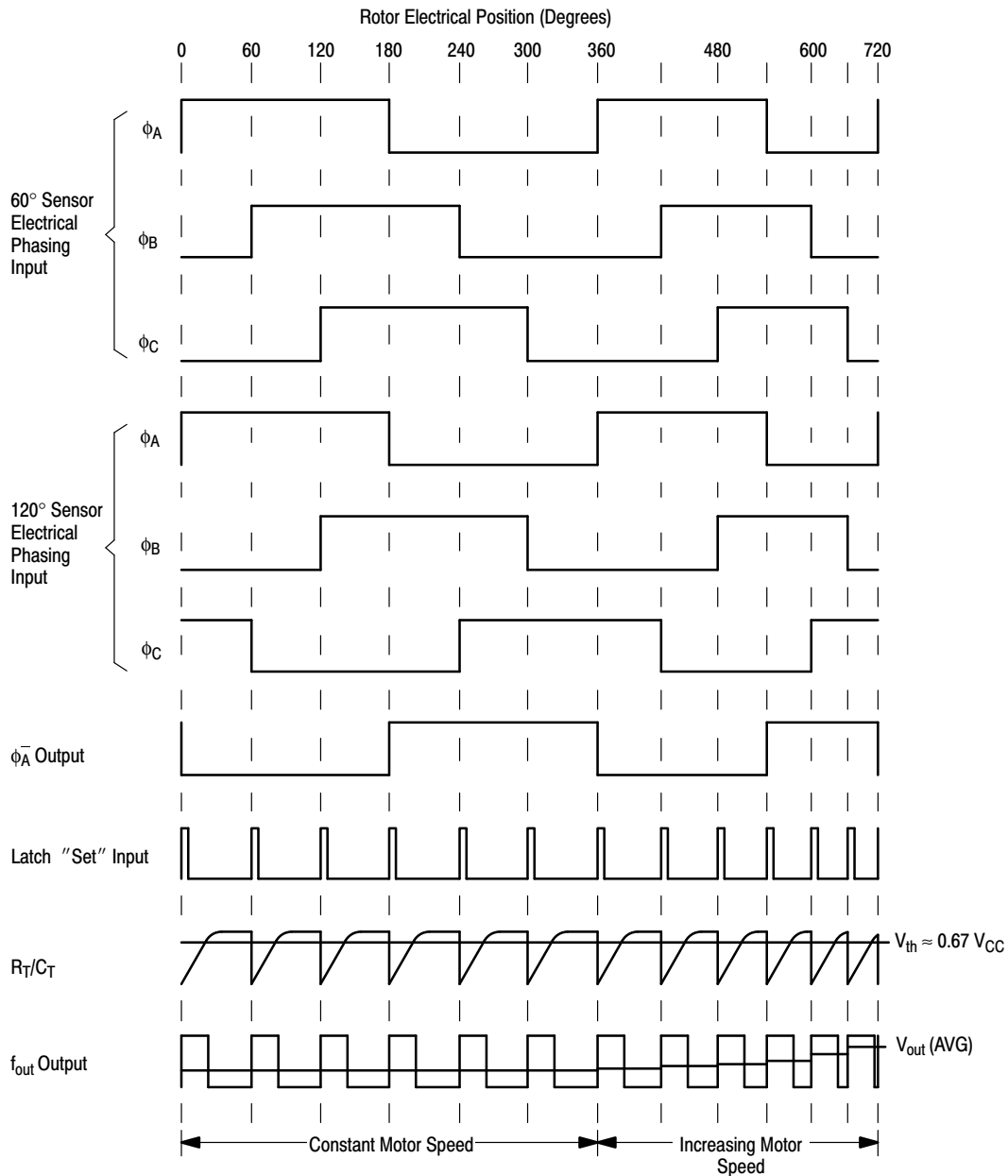

Figure 1. Typical Three Phase, Six Step Motor Application

## OPERATING DESCRIPTION

The MC33039 provides an economical method of implementing closed-loop speed control of brushless DC motors by eliminating the need for a magnetic or optical tachometer. Shown in the timing diagram of Figure 1, the three inputs (Pins 1, 2, 3) monitor the brushless motor rotor position sensors. Each sensor signal transition is digitally detected, OR'ed at the Latch 'Set' Input, and causes  $C_T$  to discharge. A corresponding output pulse is generated at  $f_{out}$  (Pin 5) of a defined amplitude, and programmable width determined by the values selected for  $R_T$  and  $C_T$  (Pin 6). The average voltage of the output pulse train increases with motor speed. When fed through a low pass filter or integrator, a DC voltage proportional to speed is generated. Figure 2 shows the proper connections for a typical closed

loop application using the MC33035 brushless motor controller. Constant speed operation down to 100 RPM is possible with economical three phase four pole motors.

The  $\phi_A$  inverter output (Pin 4) is used in systems where the controller and motor sensor phasing conventions are not compatible. A method of converting from either convention to the other is shown in Figure 3. For a more detailed explanation of this subject, refer to the text above Figure 39 on the MC33035 data sheet.

The output pulse amplitude  $V_{OH}$  is constant with temperature and controlled by the supply voltage on  $V_{CC}$  (Pin 8). Operation down to 5.5 V is guaranteed over temperature. For systems without a regulated power supply, an internal 8.25 V shunt regulator is provided.

# MC33039, NCV33039

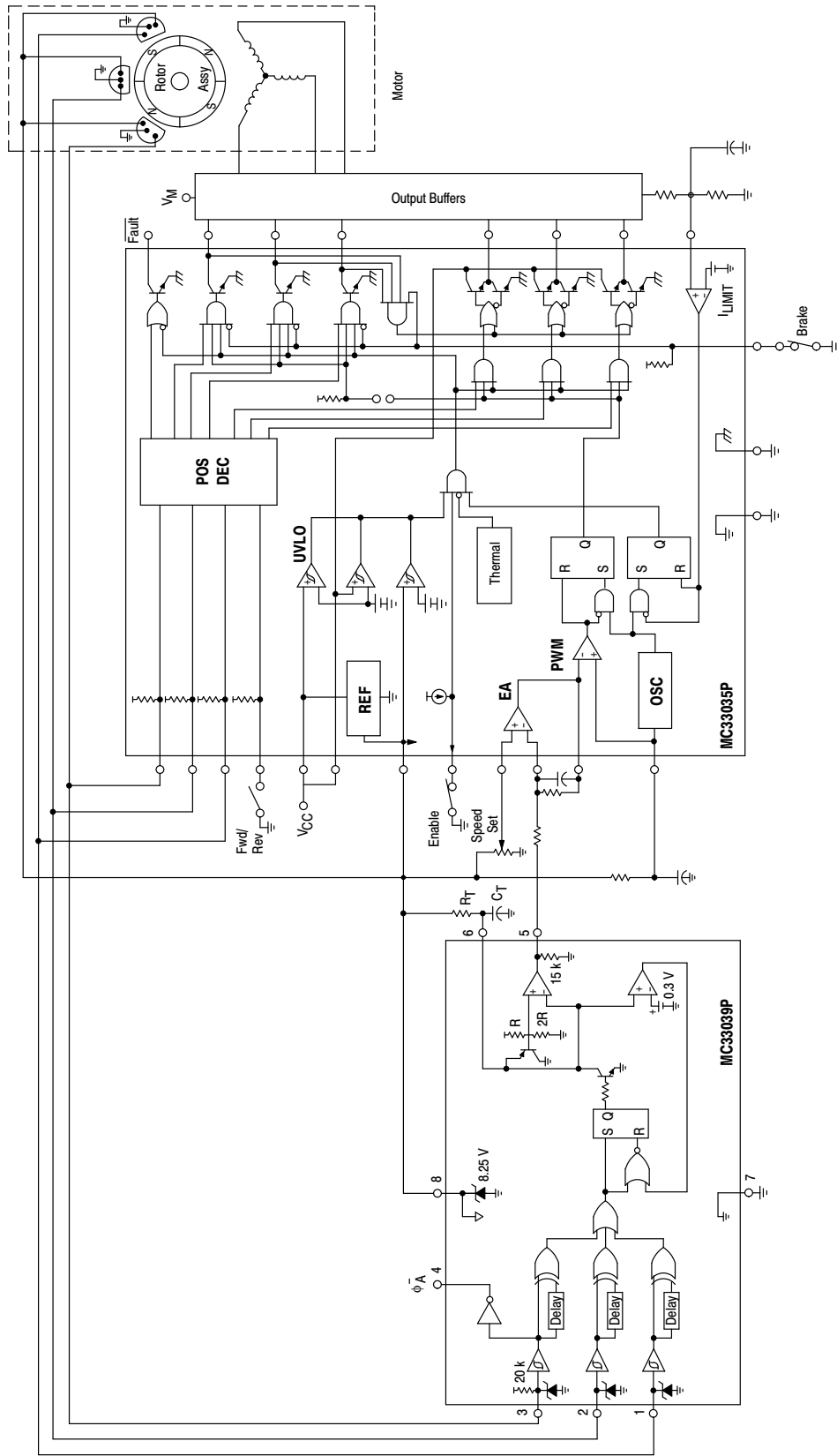

Figure 2. Typical Closed Loop Speed Control Application

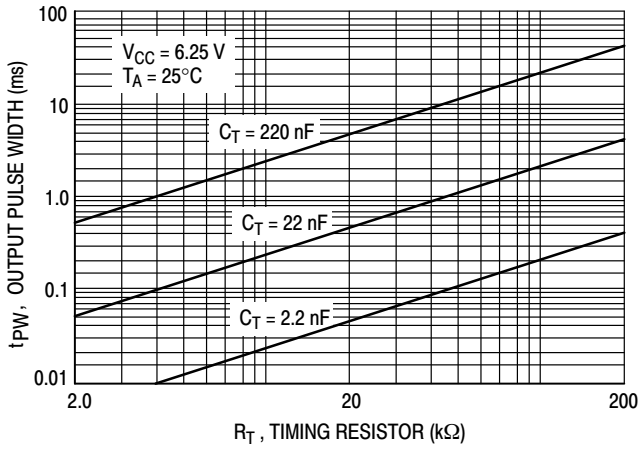

Figure 3.  $f_{out}$ , Pulse Width versus Timing Resistor

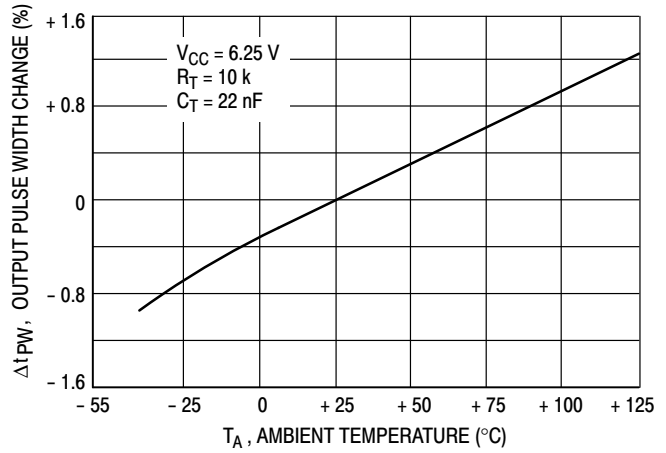

Figure 4.  $f_{out}$ , Pulse Width Change versus Temperature

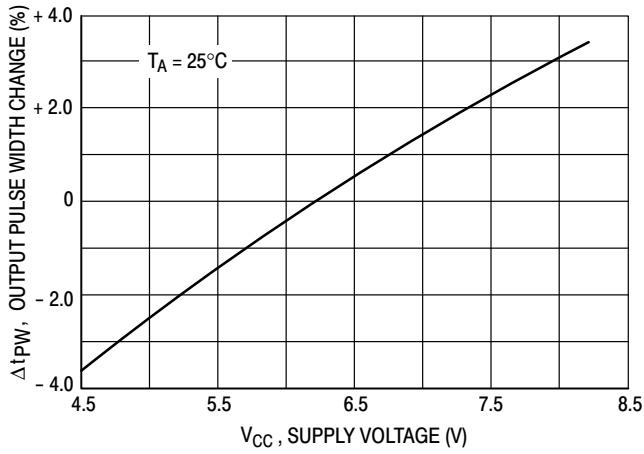

Figure 5.  $f_{out}$ , Pulse Width Change versus Supply Voltage

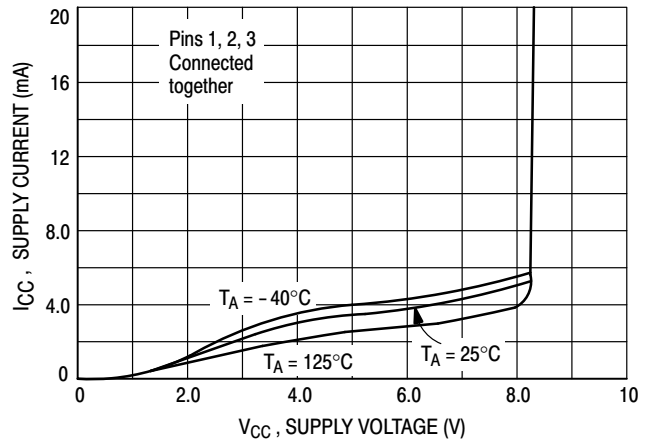

Figure 6. Supply Current versus Supply Voltage

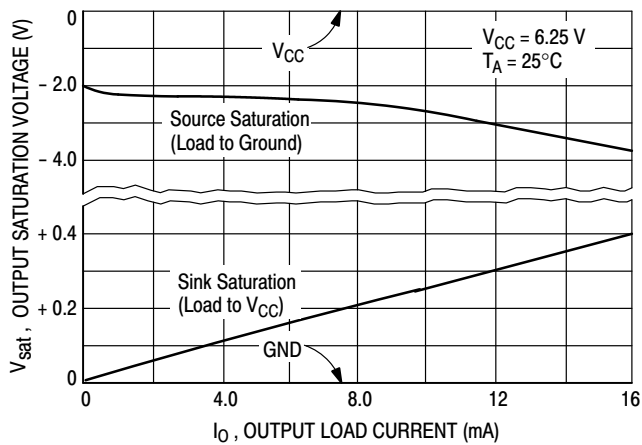

Figure 7.  $f_{out}$ , Saturation versus Load Current

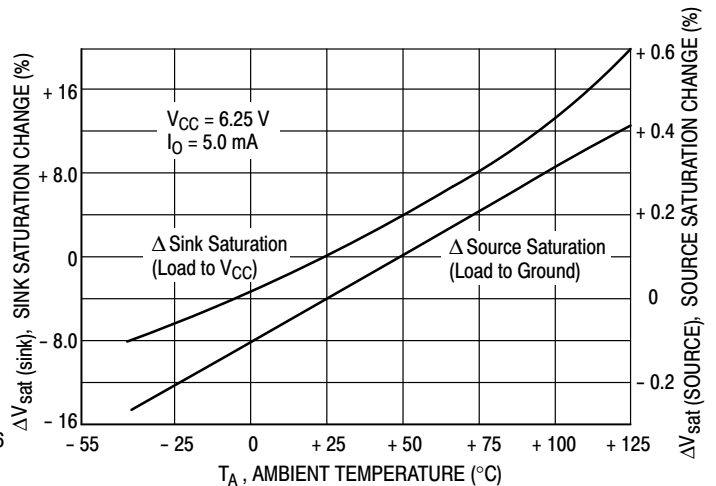

Figure 8.  $f_{out}$ , Saturation Change versus Temperature

# MC33039, NCV33039

## ORDERING INFORMATION

Device	Operating Temperature Range	Package	Shipping <sup>†</sup>
MC33039D	T <sub>A</sub> = -40°C to +85°C	SOIC-8	98 Units / Rail
MC33039DG			2500 / Tape & Reel
MC33039DR2			
MC33039DR2G		PDIP-8	
MC33039P			
MC33039PG			
NCV33039DR2*	T <sub>A</sub> = -40°C to +125°C	SOIC-8	2500 / Tape & Reel
NCV33039DR2G*			

<sup>†</sup>For information on tape and reel specifications, including part orientation and tape sizes, please refer to our Tape and Reel Packaging Specifications Brochure, BRD8011/D.

\*NCV33039: T<sub>low</sub> = -40C, T<sub>high</sub> = +125C. Guaranteed by design. NCV prefix is for automotive and other applications requiring site and change control.

# MC33039, NCV33039

## PACKAGE DIMENSIONS

P SUFFIX  
CASE 626-05  
ISSUE M

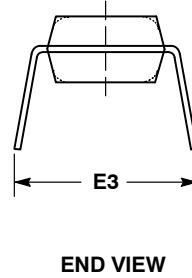
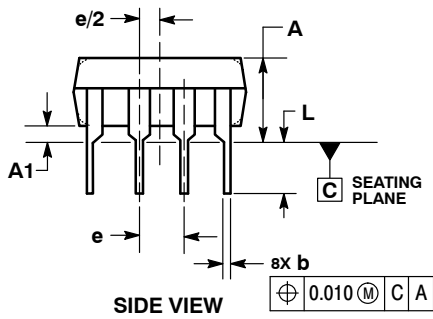
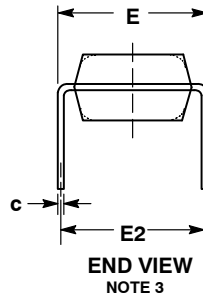
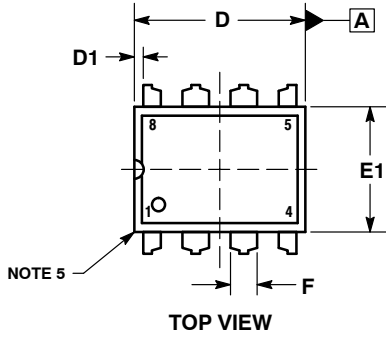

NOTES:

1. DIMENSIONING AND TOLERANCING PER ASME Y14.5M, 1994.
2. CONTROLLING DIMENSION: INCHES.
3. DIMENSION E IS MEASURED WITH THE LEADS RESTRAINED PARALLEL AT WIDTH E2.
4. DIMENSION E1 DOES NOT INCLUDE MOLD FLASH.
5. ROUNDED CORNERS OPTIONAL.

DIM	INCHES			MILLIMETERS		
	MIN	NOM	MAX	MIN	NOM	MAX
A	----	----	0.210	----	----	5.33
A1	0.015	----	----	0.38	----	----
b	0.014	0.018	0.022	0.35	0.46	0.56
C	0.008	0.010	0.014	0.20	0.25	0.36
D	0.355	0.365	0.400	9.02	9.27	10.02
D1	0.005	----	----	0.13	----	----
E	0.300	0.310	0.325	7.62	7.87	8.26
E1	0.240	0.250	0.280	6.10	6.35	7.11
E2	0.300 BSC			7.62 BSC		
E3	----	----	0.430	----	----	10.92
e	0.100 BSC			2.54 BSC		
L	0.115	0.130	0.150	2.92	3.30	3.81

# MC33039, NCV33039

## PACKAGE DIMENSIONS

SOIC-8 NB  
CASE 751-07  
ISSUE AK

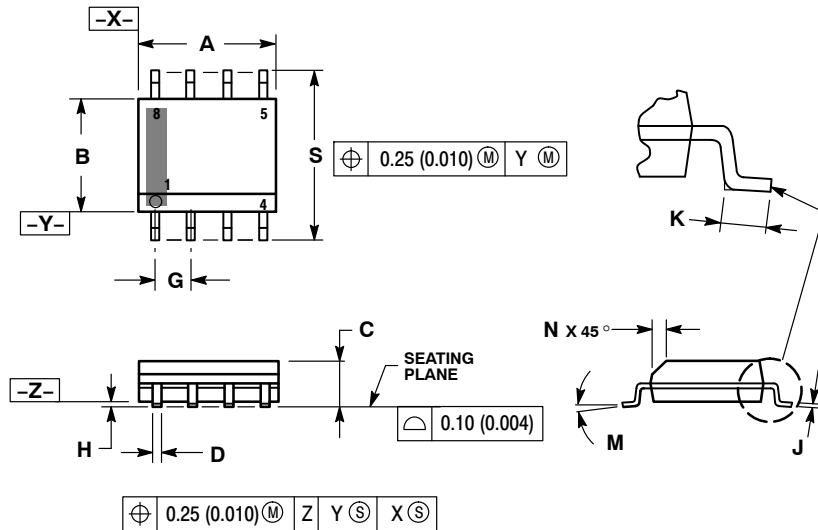

### NOTES:

1. DIMENSIONING AND TOLERANCING PER ANSI Y14.5M, 1982.
2. CONTROLLING DIMENSION: MILLIMETER.
3. DIMENSION A AND B DO NOT INCLUDE MOLD PROTRUSION.
4. MAXIMUM MOLD PROTRUSION 0.15 (0.006) PER SIDE.
5. DIMENSION D DOES NOT INCLUDE DAMBAR PROTRUSION. ALLOWABLE DAMBAR PROTRUSION SHALL BE 0.127 (0.005) TOTAL IN EXCESS OF THE D DIMENSION AT MAXIMUM MATERIAL CONDITION.
6. 751-01 THRU 751-06 ARE OBSOLETE. NEW STANDARD IS 751-07.

DIM	MILLIMETERS		INCHES	
	MIN	MAX	MIN	MAX
A	4.80	5.00	0.189	0.197
B	3.80	4.00	0.150	0.157
C	1.35	1.75	0.053	0.069
D	0.33	0.51	0.013	0.020
G	1.27 BSC		0.050 BSC	
H	0.10	0.25	0.004	0.010
J	0.19	0.25	0.007	0.010
K	0.40	1.27	0.016	0.050
M	0°	8°	0°	8°
N	0.25	0.50	0.010	0.020
S	5.80	6.20	0.228	0.244

### SOLDERING FOOTPRINT\*

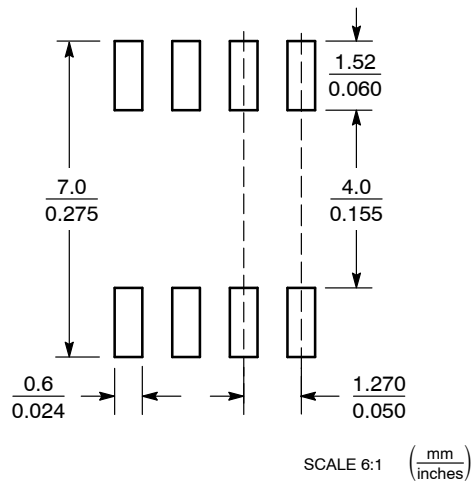

\*For additional information on our Pb-Free strategy and soldering details, please download the ON Semiconductor Soldering and Mounting Techniques Reference Manual, SOLDERRM/D.

ON Semiconductor and are registered trademarks of Semiconductor Components Industries, LLC (SCILLC). SCILLC owns the rights to a number of patents, trademarks, copyrights, trade secrets, and other intellectual property. A listing of SCILLC's product/patent coverage may be accessed at [www.onsemi.com/site/pdf/Patent-Marking.pdf](http://www.onsemi.com/site/pdf/Patent-Marking.pdf). SCILLC reserves the right to make changes without further notice to any products herein. SCILLC makes no warranty, representation or guarantee regarding the suitability of its products for any particular purpose, nor does SCILLC assume any liability arising out of the application or use of any product or circuit, and specifically disclaims any and all liability, including without limitation special, consequential or incidental damages. "Typical" parameters which may be provided in SCILLC data sheets and/or specifications can and do vary in different applications and actual performance may vary over time. All operating parameters, including "Typicals" must be validated for each customer application by customer's technical experts. SCILLC does not convey any license under its patent rights nor the rights of others. SCILLC products are not designed, intended, or authorized for use as components in systems intended for surgical implant into the body, or other applications intended to support or sustain life, or for any other application in which the failure of the SCILLC product could create a situation where personal injury or death may occur. Should Buyer purchase or use SCILLC products for any such unintended or unauthorized application, Buyer shall indemnify and hold SCILLC and its officers, employees, subsidiaries, affiliates, and distributors harmless against all claims, costs, damages, and expenses, and reasonable attorney fees arising out of, directly or indirectly, any claim of personal injury or death associated with such unintended or unauthorized use, even if such claim alleges that SCILLC was negligent regarding the design or manufacture of the part. SCILLC is an Equal Opportunity/Affirmative Action Employer. This literature is subject to all applicable copyright laws and is not for resale in any manner.

### PUBLICATION ORDERING INFORMATION

**LITERATURE FULFILLMENT:**  
Literature Distribution Center for ON Semiconductor  
P.O. Box 5163, Denver, Colorado 80217 USA  
Phone: 303-675-2175 or 800-344-3860 Toll Free USA/Canada  
Fax: 303-675-2176 or 800-344-3867 Toll Free USA/Canada  
Email: [orderlit@onsemi.com](mailto:orderlit@onsemi.com)

**N. American Technical Support:** 800-282-9855 Toll Free  
USA/Canada  
**Europe, Middle East and Africa Technical Support:**  
Phone: 421 33 790 2910  
**Japan Customer Focus Center**  
Phone: 81-3-5817-1050

**ON Semiconductor Website:** [www.onsemi.com](http://www.onsemi.com)  
**Order Literature:** <http://www.onsemi.com/orderlit>  
For additional information, please contact your local Sales Representative

## Looking for pricing, stock, or lifecycle information?

Click below to explore more details on WIN SOURCE:

 [View NCV33039DR2G on WIN SOURCE](#)

 [ON Semiconductor](#) Information

## Optimize Your Supply Chain with WIN SOURCE Solutions

-  Global Sourcing Solution
-  Obsolete Management
-  Cost Control Management
-  Shortage Management
-  Alternative Solution
-  Excess Inventory Management