



**THE DATASHEET OF  
MP6505DQ-LF-Z**



## DESCRIPTION

The MP6505 is a single-phase brushless-DC-motor driver, with an input voltage range of 4.5V to 16V and a maximum output current of 400mA.

The MP6505 controls the rotational speed through either the input voltage or the PWM signal. Other features include minimum-rotational-speed set, a rotational speed indicator, built-in input over-voltage protection, built-in locked-rotor protection, locked-rotor-state indicator, thermal shutdown, and a 1.2V integrated Hall bias voltage.

The MP6505 is available in 5.0mm×6.4mm TSSOP16 package.

## FEATURES

- Operating Voltage of 4.5V to 16V
- Integrated Power MOSFETs (HS: 370mΩ; LS: 230mΩ)
- Maximum Output Current 400mA
- Low Quiescent Current (Not including Hall Sensor) of 1.4mA
- Speed Control by Input Voltage or PWM Signal
- Programmable Minimum Speed
- Rotational-Speed Indicator
- Locked-Rotor Indicator
- Locked-Rotor Protection and Automatic Recovery
- Thermal Protection and Automatic Recovery
- Built-In Input OVP and Automatic Recovery
- Hall Bias Voltage(1.2V) Integrated
- Available in TSSOP16 (5.0×6.4mm) Package

## APPLICATIONS

- CPU Fan for Personal Computers or Servers
- Brushless DC Motor Driver

All MPS parts are lead-free, halogen free, and adhere to the RoHS directive. For MPS green status, please visit MPS website under Quality Assurance. "MPS" and "The Future of Analog IC Technology" are Registered Trademarks of Monolithic Power Systems, Inc.

## TYPICAL APPLICATION

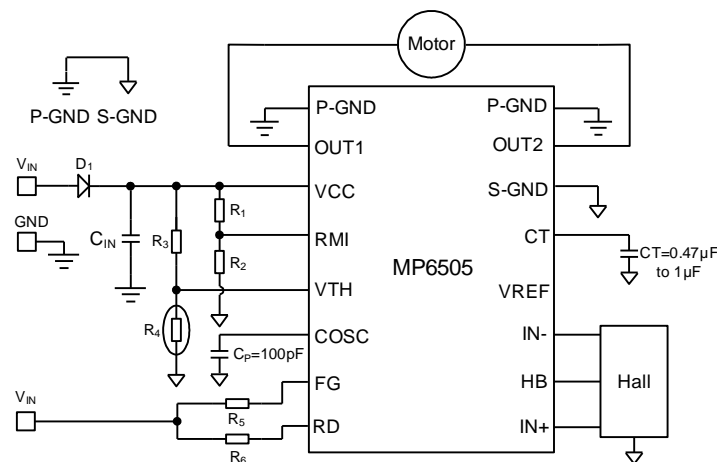

### ORDERING INFORMATION

Part Number	Package	Top Marking
MP6505DM*	TSSOP16(5.0x6.4mm)	MP6505

\* For Tape & Reel, add suffix -Z (eg. MP6505DM-Z);  
 For RoHS compliant packaging, add suffix -LF (e.g. MP6505DM-LF-Z)

### PACKAGE REFERENCE

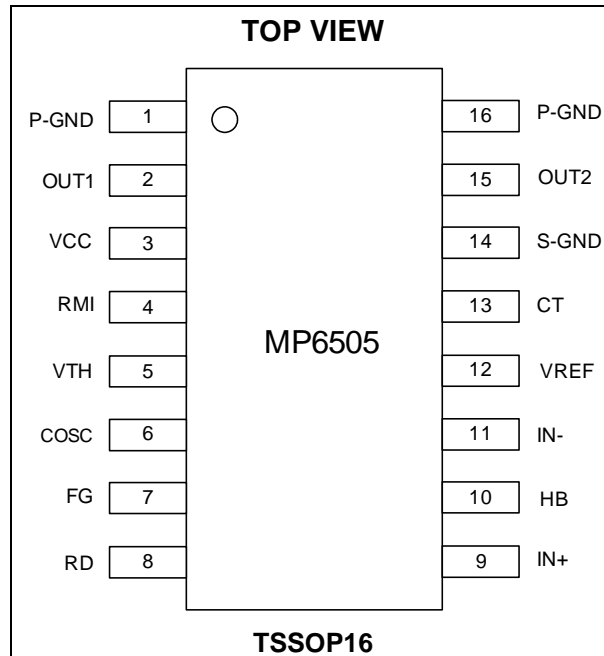

### ABSOLUTE MAXIMUM RATINGS<sup>(1)</sup>

V <sub>CC</sub> .....	0V to 20V
OUT1, OUT2.....	-1V to 20V
FG, RD.....	-0.3V to 18V
All other Pins.....	-0.3V to 6.5V
Continuous Power Dissipation (T <sub>A</sub> = 25°C) <sup>(2)</sup>	
TSSOP16.....	1.17W
Junction Temperature.....	150°C
Storage Temperature.....	-55°C to +150°C

### Recommended Operating Conditions<sup>(3)</sup>

V <sub>CC</sub> .....	4.5V to 16V
V <sub>TH</sub> .....	0V to 6V
IN+, IN-.....	0.2V to 3V
Operating Junction Temp. (T <sub>J</sub> ).....	-40°C to +125°C

### Thermal Resistance<sup>(4)</sup>

	$\theta_{JA}$	$\theta_{JC}$
TSSOP16 (5.0x6.4mm) .....	90	30 ... °C/W

#### Notes:

- Exceeding these ratings may damage the device.
- The maximum allowable power dissipation is a function of the maximum junction temperature T<sub>J</sub> (MAX), the junction-to-ambient thermal resistance  $\theta_{JA}$ , and the ambient temperature T<sub>A</sub>. The maximum allowable continuous power dissipation at any ambient temperature is calculated by P<sub>D</sub> (MAX) = (T<sub>J</sub> (MAX)-T<sub>A</sub>)/ $\theta_{JA}$ . Exceeding the maximum allowable power dissipation will cause excessive die temperature, and the regulator will go into thermal shutdown. Internal thermal shutdown circuitry protects the device from permanent damage.
- The device is not guaranteed to function outside of its operating conditions.(For V<sub>CC</sub> voltage range, it doesn't include the external input diode voltage drop)
- Measured on JESD51-7, 4-layer PCB.

## ELECTRICAL CHARACTERISTICS

$T_A=25^{\circ}\text{C}$ ,  $V_{CC}=12\text{V}$ , unless otherwise noted.

Parameter	Symbol	Condition	Min	Typ	Max	Unit
Circuit Current in Locked-Rotor Protection Mode	$I_{CC}$	$V_{CC}=20\text{V}$	1.0	1.4	2	mA
Reference Voltage	$V_{REF}$	$I_{VREF}=5\text{mA}$	5.6	5.9	6.2	V
HB Voltage	$V_{HB}$	$I_{HB}=5\text{mA}$	1.1	1.15	1.2	V
COSC HIGH Voltage	$V_{COSC\ H}$		3.45	3.6	3.75	V
COSC LOW Voltage	$V_{COSC\ L}$		1.8	1.95	2.1	V
COSC Oscillator Frequency	$f_{COSC}$	$CP=100\text{pF}$	26.4	31	35.6	kHz
CT Pin HIGH Voltage	$V_{CTH}$		3.4	3.63	3.86	V
CT Pin LOW Voltage	$V_{CTL}$		1.63	1.73	1.83	V
$I_{CT}$ Charge Current	$I_{CT1}$		1.1	1.95	2.85	$\mu\text{A}$
$I_{CT}$ Discharge Current	$I_{CT2}$		0.08	0.16	0.25	$\mu\text{A}$
$I_{CT}$ Charge/Discharge Ratio	$r_{CT}$		7	12	18	
High-Side Switch-On Resistance	$R_{DS1}$	$V_{CC}=12\text{V}$ $T_A=25^{\circ}\text{C}$		370	420	$\text{m}\Omega$
Low-Side Switch-On Resistance	$R_{DS2}$	$V_{CC}=12\text{V}$ $T_A=25^{\circ}\text{C}$		230	260	$\text{m}\Omega$
Current Limit Gain	$G_C$			9		A/V
Current Limit	$I_{PEAK}$	$IN+ - IN- = \pm 50\text{mV}$	0.4	0.7	1.3	A
		$IN+ - IN- = \pm 100\text{mV}$	0.8	1	1.8	
Under-Voltage Lockout Threshold—Rising			3.57	3.75	3.93	V
Under-Voltage Lockout Threshold—Hysteresis				190		mV
RD/FG Output Pin Low-Level Voltage	$V_{RDL/FGL}$	$I_{RD/FG}=5\text{mA}$			0.35	V
RD/FG Output Pin Leakage Current	$V_{RDL/FGL}$	$V_{RD/FG}=12\text{V}$		0.1	1	$\mu\text{A}$
OVP Threshold Rising			19	20	21	V
OVP Threshold Hysteresis				1.7		V

## PIN FUNCTIONS

Pin # (TSSOP16)	Name	Description
1,16	P-GND	Power Ground.
2	OUT1	Motor Driver Output 1.
3	VCC	Power Supply.
4	RMI	Minimum Rotational Speed Set.
5	VTH	Rotational Speed Control. Use DC voltage or PWM signal.
6	COSC	Oscillator Setting. Connect this pin to an external capacitor to set the switch frequency.
7	FG	Rotational Speed Detector. Connect to an external power source through a pull-up resistor.
8	RD	Locked-Rotor Protection Detector. Connect to an external power source through a pull-up resistor.
9	IN+	Hall Sensor Input+. For rotor position detection and current limit setting.
10	HB	Hall Sensor Bias Regulator Output. Powers the external Hall sensor.
11	IN-	Hall Sensor Input-. For rotor position detection and current limit setting.
12	VREF	Reference Voltage Output.
13	CT	Locked-Rotor Protection and Recovery Time Set. Connect to an external capacitor to set the recovery time.
14	S-GND	Ground for Control Circuit.
15	OUT2	Motor Driver Output 2.
	NC	Not Connected. Connect exposed thermal pad to power ground for better thermal performance.

## TYPICAL CHARACTERISTICS

$V_{IN}=12V$ ,  $f_{OSC}=30kHz$

**UVLO vs. Temperature**

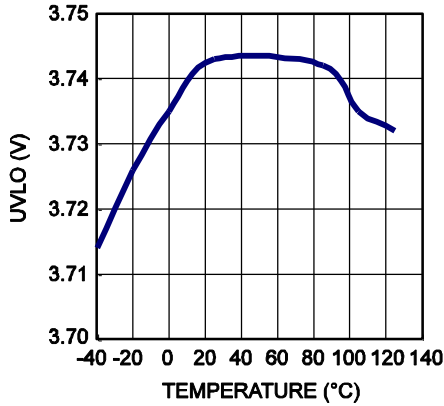

**ICC vs. Temperature**

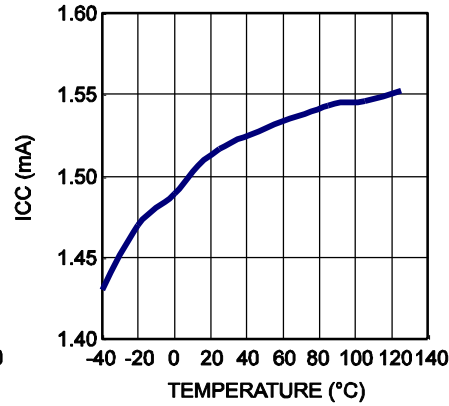

**VCC Breakdown Voltage vs. Temperature**

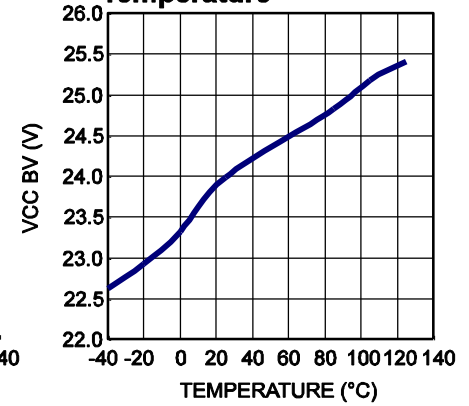

**Frequency vs. Temperature**

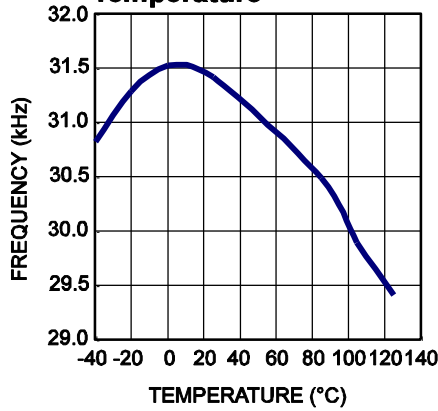

**VHB vs. Temperature**

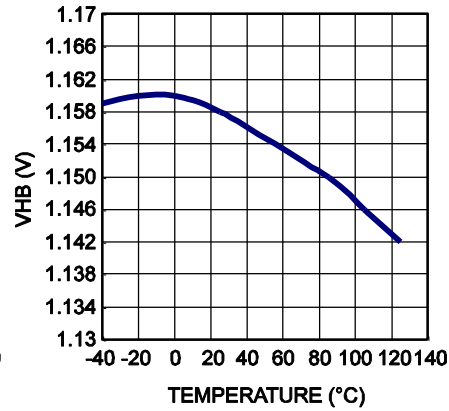

**VREF vs. Temperature**

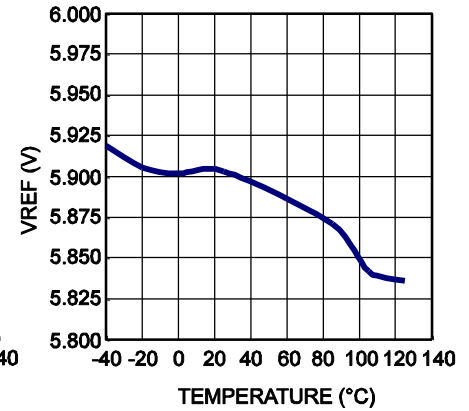

## TYPICAL PERFORMANCE CHARACTERISTICS

$f_{\text{OSC}}=30\text{kHz}$ ,  $C_T=1\mu\text{F}$ ,  $V_{\text{TH}}=0\text{V}$ ,  $V_{\text{IN}}=12\text{V}$ ,  $C_{\text{IN}}=10\mu\text{F}$ ,  $L_{\text{motor}}=5\text{mH}$ ,  $R_{\text{motor}}=10\Omega$ ,  $T_A=25^\circ\text{C}$ , unless otherwise noted.

### Steady State

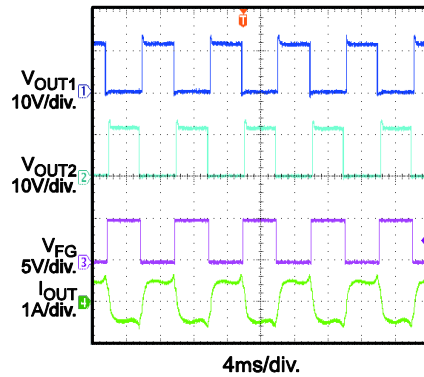

### Locked-rotor Protection

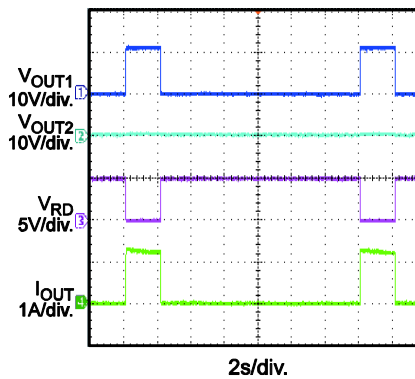

### Power Ramp Up

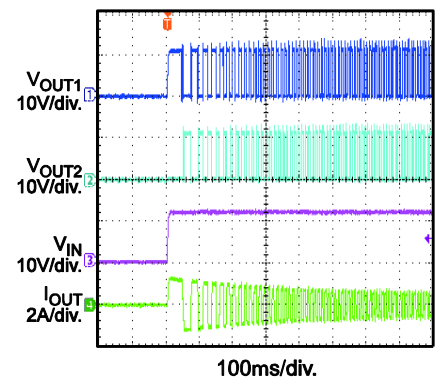

### Power Ramp Down

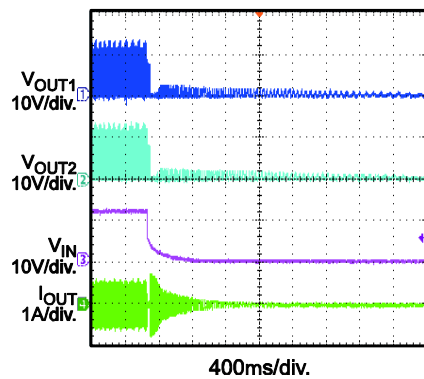

### BLOCK DIAGRAM

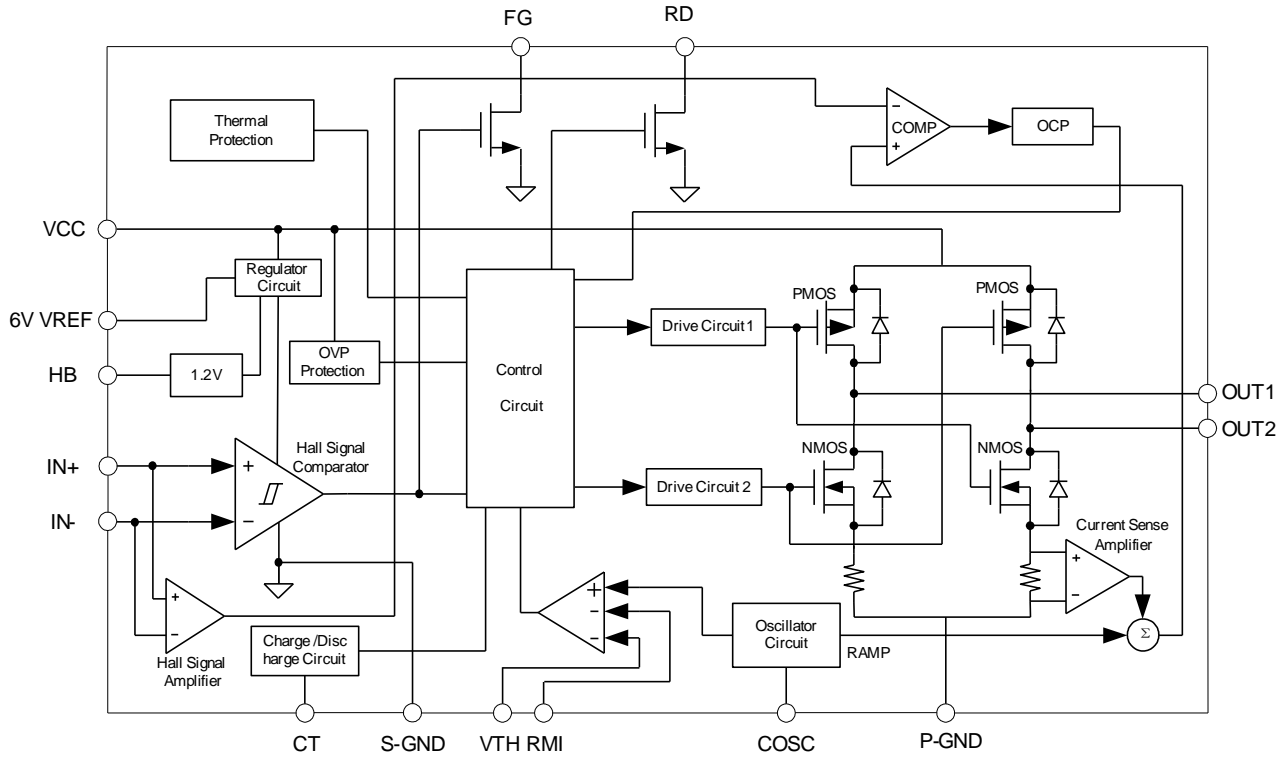

Figure 1: Functional Block Diagram

## FUNCTION DESCRIPTION

### Motor Driver

The OUT1 and OUT2 pins drive the motor with a maximum continuous output current of 400mA at room temperature. The peak output current value is proportional to the Hall sensor output voltage of ( $V_{IN+}-V_{IN-}$ ).

### Frequency Setting

A capacitor at the COSC pin sets the frequency. For most applications, use a 100pF capacitor for a typical PWM frequency of 30kHz.

### Minimum Speed

The voltage on RMI pin sets the minimum PWM duty cycle, which sets the lowest speed. Connect to VTH if not used.

### Locked-Rotor Detection

The RD pin is the locked-rotor detector, and is the output of an open collector. It goes low when the motor rotates and goes into high impedance if the motor is in a locked-rotor state. Leave it open if not used.

### Speed Detection

The rotational speed detector (the FG pin) is the output of an open collector. It outputs a high or low voltage relative to the Hall comparator's output. Higher speeds produce higher-frequency signals. Leave it open if not used.

### Current Limit and the Hall Signal

An internal amplifier with hysteresis amplifies the differential Hall signal: The output of this amplifier serves as the current-limit value. The differential Hall voltage drops to 0V whenever an opposing magnet passes the Hall sensor to limit the peak current during commutation. The Hall sensor is directly powered by a 1.2V voltage on the HB pin. The Hall sensor input sensitivity accepted by the part is down to 3mV.

### Input Over-Voltage Protection

The reverse current generated with every commutation charges the input capacitor and causes a periodic voltage spike at the input pin. The internal input over-voltage protection (OVP) circuit turns off two HS switches when a spike exceeds 20V, and recovers from OVP when the spike is less than 18V.

### Over Temperature Protection

The MOSFET is shutdown when the temperature exceeds about 175°C and resumes working once the temperature is below about 155°C.

### Working Mode

The driver has operates in one of four modes under normal conditions, as shown in Figure 2. The following describes each mode:

- **Minimum Speed Mode**

This mode runs the motor at the slowest motor speed. It uses a thermistor to provide the VTH signal and compares it against RMI to determine the slowest motor speed.

At low temperatures, VTH exceeds RMI. The device compares  $V_{COSC}$  against RMI to generate a PWM signal,  $PWM_{RMI}$ , to control the motor speed. Removing the thermistor causes VTH and the motor speed to reach their respective maxima and minima.

- **Variable Speed Mode**

When the VTH signal falls below RMI, the device compares  $V_{COSC}$  against VTH to generate a PWM signal of  $PWM_{VTH}$  to control the motor speed. In general, VTH controls the PWM duty cycle, and therefore the motor speed.

- **Full-Speed Mode**

When the VTH signal is less than  $V_{COSC(MIN)}$ , the PWM duty is 100% and the motor speed is at its maximum.

- **Locked-Rotor-Protection Mode**

An internal current source,  $I_{CT1}$ , charges the capacitor at the CT pin; changing the Hall comparator's output provides a reset signal to drive an internal switch to discharge this capacitor to  $V_{CTL}$ .

If the motor rotor is locked, the Hall comparator's output will not change. Once the voltage on the capacitor goes to  $V_{CTH}$ , the driver enters locked-rotor-protection mode and another current source,  $I_{CT2}$ , discharges the CT capacitor. During this period, the PWM duty cycle goes to 0% and the RD pin is in a high-impedance state. When the voltage on the capacitor drops to 0V,  $I_{CT1}$  charges the capacitor again. The PWM signal resumes switching to try to drive motor again. If the rotor remains locked, the process repeats.

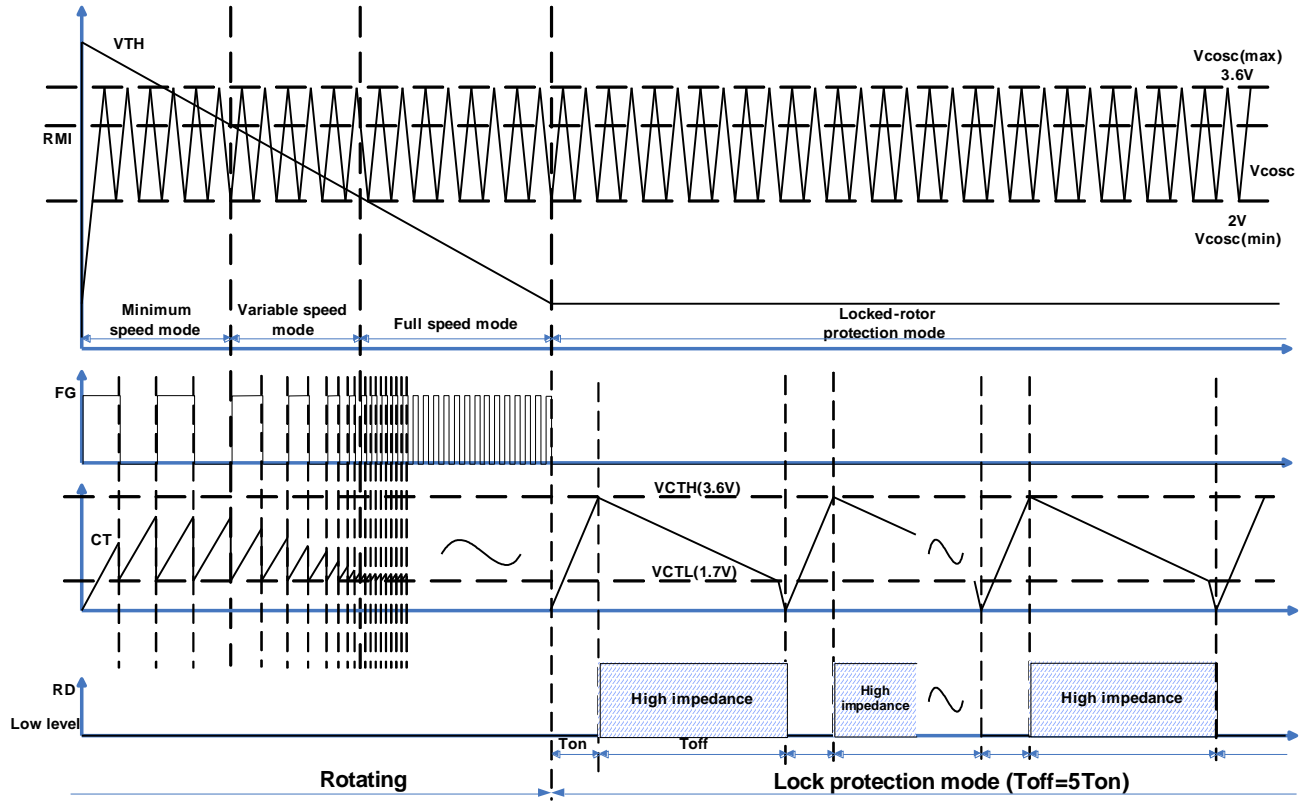

Figure 2: Driver Operation Mode

## APPLICATION INFORMATION

### Selecting the Input Capacitor

The input capacitor absorbs excess armature inductor energy with every commutation. For typical applications, select  $C_{IN} \geq 10\mu F$  to provide a margin of safety for input OVP. Motors with larger armature inductors require larger input capacitors.

### Setting the Frequency

For most applications, use a 100pF capacitor for the  $C_P$  capacitor to set the frequency to 30kHz.  $f_{OSC}$  is determined by:

$$f_{OSC} = 3 \times 10^{-6} / C_P (\text{Hz})$$

### Connecting the Motor

Figure 3 shows that the OUT1 and OUT2 connect to the motor armature: When  $V_{IN+}$  exceeds  $V_{IN-}$ , SW1 and SW4 activate and current flows from OUT1 to OUT2; When  $V_{IN-}$  exceeds  $V_{IN+}$ , SW2 and SW3 activate and current flows from OUT2 to OUT1. The opposing current directions generate opposing polarities in the armature winding. For most applications, carefully connect OUT1 and OUT2 to the motor terminators according to the Hall sensor setting position. Incorrect connections will cause abnormal motor function.

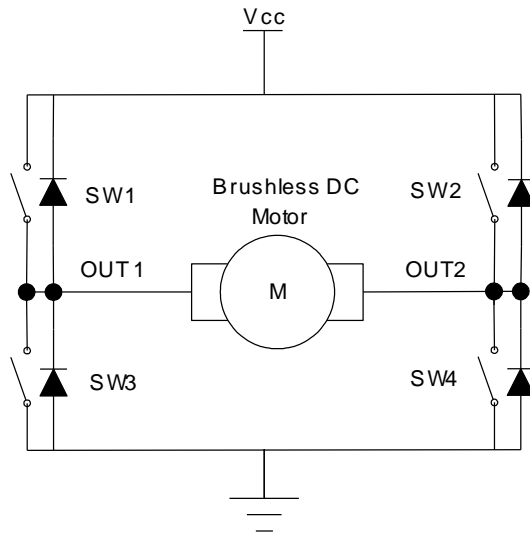

**Figure 3: Power Stage**

### Design Example

Below is an example design that follows the application guidelines for the given specifications:

$V_{IN}$	4.5V to 16V
$I_{OUT}(\text{Max})$	400mA
$f_{OSC}$	30kHz

Figure 4 shows a detailed application schematic. For more applications, please refer to the related Evaluation Board Data Sheets.

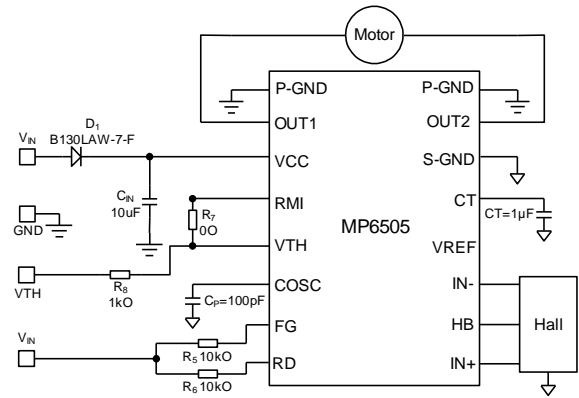

**Figure 4: Detailed Application Schematic**

## PACKAGE INFORMATION

### TSSOP16 (5.0X6.4mm)

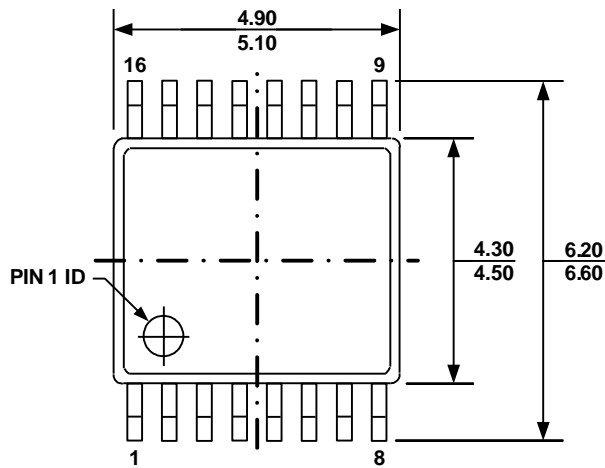

**TOP VIEW**

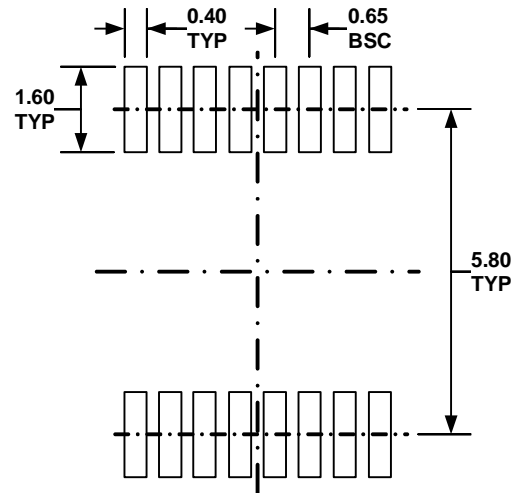

**RECOMMENDED LAND PATTERN**

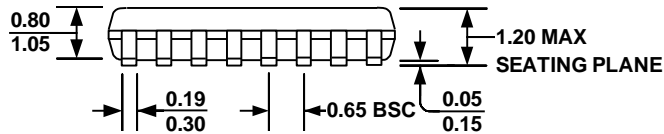

**FRONT VIEW**

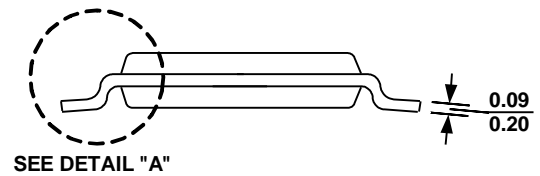

**SIDE VIEW**

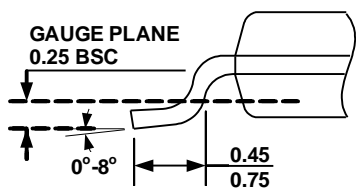

**DETAIL "A"**



**NOTE:**

- 1) ALL DIMENSIONS ARE IN MILLIMETERS
- 2) PACKAGE LENGTH DOES NOT INCLUDE MOLD FLASH, PROTRUSION OR GATE BURR
- 3) PACKAGE WIDTH DOES NOT INCLUDE INTERLEAD FLASH OR PROTRUSION.
- 4) LEAD COPLANARITY (BOTTOM OF LEADS AFTER FORMING) SHALL BE 0.10 MILLIMETERS MAX
- 5) DRAWING CONFORMS TO JEDEC MO-153, VARIATION AB
- 6) DRAWING IS NOT TO SCALE

**NOTICE:** The information in this document is subject to change without notice. Users should warrant and guarantee that third party Intellectual Property rights are not infringed upon when integrating MPS products into any application. MPS will not assume any legal responsibility for any said applications.

## Looking for pricing, stock, or lifecycle information?

Click below to explore more details on WIN SOURCE:

-  [View MP6505DQ-LF-Z on WIN SOURCE](#)
-  [Monolithic Power Systems Inc. Information](#)

## Optimize Your Supply Chain with WIN SOURCE Solutions

-  Global Sourcing Solution
-  Obsolete Management
-  Cost Control Management
-  Shortage Management
-  Alternative Solution
-  Excess Inventory Management