



**THE DATASHEET OF
CA5260AM96**



CA5260, CA5260A

3MHz, BiMOS Microprocessor Operational Amplifiers with MOSFET Input/CMOS Output

FN1929
Rev 8.00
August 3, 2010

The CA5260A and CA5260 are integrated-circuit operational amplifiers that combine the advantage of both CMOS and bipolar transistors on a monolithic chip. The CA5260 series circuits are dual versions of the popular CA5160 series. They are designed and guaranteed to operate in microprocessor or logic systems that use +5V supplies.

Gate-protected P-Channel MOSFET (PMOS) transistors are used in the input circuit to provide very-high-input impedance, very-low-input current, and exceptional speed performance. The use of PMOS field-effect transistors in the input stage results in common-mode input-voltage capability down to 0.5V below the negative-supply terminal, an important attribute in single-supply applications.

A complementary-symmetry MOS (CMOS) transistor-pair, capable of swinging the output voltage to within 10mV of either supply-voltage terminal (at very high values of load impedance), is employed as the output circuit.

The CA5260 Series circuits operate at supply voltages ranging from 4.5V to 16V, or ±2.25V to ±8V when using split supplies.

The CA5260, CA5260A have guaranteed specifications for 5V operation over the full military temperature range of -55°C to +125°C.

Pinout

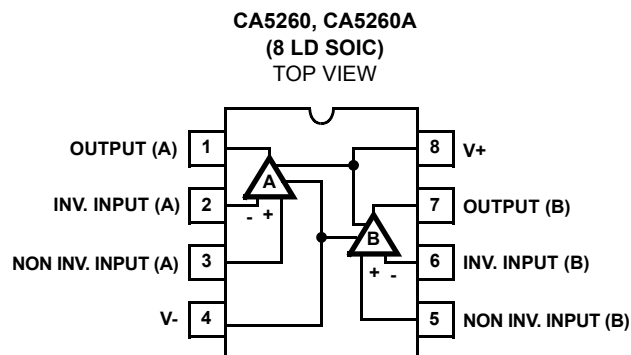

Features

- MOSFET Input Stage provides
 - Very High Z_i $1.5T\Omega$ ($1.5 \times 10^{12}\Omega$) (Typ)
 - Very Low I_i 5pA (Typ) at 15V Operation
2pA (Typ) at 5V Operation
- Ideal for Single Supply Applications
- Common Mode Input Voltage Range Includes Negative Supply Rail; Input Terminals Can be Swung 0.5V Below Negative Supply Rail
- CMOS Output Stage Permits Signal Swing to Either (or Both) Supply Rails
- CA5260A, CA5260 Have Full Military Temperature Range Guaranteed Specifications for $V_+ = 5V$
- CA5260A, CA5260 are Guaranteed to Operate Down to 4.5V for A_{OL}
- Fully Guaranteed to Operate from -55°C to +125°C at $V_+ = 5V, V_- = GND$
- Pb-Free Available (RoHS Compliant)

Applications

- Ground Referenced Single Supply Amplifiers
- Fast Sample-Hold Amplifiers
- Long Duration Timers/Monostables
- Ideal Interface with Digital CMOS
- High Input Impedance Wideband Amplifiers
- Voltage Followers (e.g., Follower for Single Supply D/A Converter)
- Voltage Regulators (Permits Control of Output Voltage Down to 0V)
- Wien Bridge Oscillators
- Voltage Controlled Oscillators
- Photo Diode Sensor Amplifiers
- 5V Logic Systems
- Microprocessor Interface

Ordering Information

PART NUMBER (Note 3)	PART MARKING	TEMP. RANGE (°C)	PACKAGE (Pb-Free)	PKG. DWG. #
CA5260AM96 (Note 1)	5260A	-55 to +125	8 Ld SOIC (Tape and Reel)	M8.15
CA5260MZ96 (Note 2)	CA5260 MZ	-55 to +125	8 Ld SOIC	M8.15
CA5260M (Notes 1)	5260	-55 to +125	8 Ld SOIC (Tape and Reel)	M8.15
CA5260MZ (Note 2)	CA5260 MZ	-55 to +125	8 Ld SOIC	M8.15

NOTES:

1. Please refer to [TB347](#) for details on reel specifications.
2. These Intersil Pb-free plastic packaged products employ special Pb-free material sets, molding compounds/die attach materials, and 100% matte tin plate plus anneal (e3 termination finish, which is RoHS compliant and compatible with both SnPb and Pb-free soldering operations). Intersil Pb-free products are MSL classified at Pb-free peak reflow temperatures that meet or exceed the Pb-free requirements of IPC/JEDEC J STD-020.
3. For Moisture Sensitivity Level (MSL), please see device information page for [CA5260](#), [CA5260A](#). For more information on MSL please see techbrief [TB363](#).

Absolute Maximum Ratings

Supply Voltage (Between V+ and V- Terminals)	16V
Differential Input Voltage	8V
Input Voltage	(V+ +8V) to (V- -0.5V)
Input Current	1mA
Output Short Circuit Duration (Note 4)	Indefinite
Temperature Range	-55°C to +125°C

Thermal Information

Thermal Resistance (Typical, Note 5)	θ_{JA} (°C/W)
SOIC Package	157
Maximum Junction Temperature (Die)	175°C
Maximum Junction Temperature (Plastic Package)	+150°C
Maximum Storage Temperature Range	-65°C to +150°C
Pb-Free Reflow Profile	see link below http://www.intersil.com/pbfree/Pb-FreeReflow.asp

CAUTION: Do not operate at or near the maximum ratings listed for extended periods of time. Exposure to such conditions may adversely impact product reliability and result in failures not covered by warranty.

NOTES:

- Short circuit may be applied to ground or to either supply.
- θ_{JA} is measured with the component mounted on an evaluation PC board in free air.

Electrical Specifications Typical Values Intended Only for Design Guidance, V+ = 5V, V- = 0V, T_A = +25°C, Unless Otherwise Specified

PARAMETER	SYMBOL	TEST CONDITIONS	TYPICAL VALUES		UNITS
			CA5260	CA5260A	
Input Resistance	R _I		1.5	1.5	TΩ
Input Capacitance	C _I	f = 1MHz	4.3	4.3	pF
Unity Gain Crossover Frequency	f _T		3	3	MHz
Slew Rate	SR	V _{OUT} = 2.5V _{P-P}	5	5	V/μs
Transient Response	Rise Time	C _L = 25pF, R _L = 2kΩ (Voltage Follower)	0.09	0.09	μs
Settling Time (To <0.1%, V _{IN} = 4V _{P-P})	t _S	C _L = 25pF, R _L = 2kΩ (Voltage Follower)	1.8	1.8	μs

Electrical Specifications T_A = +25°C, V+ = 5V, V- = 0V

PARAMETER	SYMBOL	TEST CONDITIONS	CA5260			CA5260A			UNITS
			MIN	TYP	MAX	MIN	TYP	MAX	
Input Offset Voltage	V _{IO}	V _O = 2.5V	-	2	15	-	1.5	4	mV
Input Offset Current	I _{IO}	V _O = 2.5V	-	1	10	-	1	10	pA
Input Current	I _I	V _O = 2.5V	-	2	15	-	2	15	pA
Common Mode Rejection Ratio	CMRR	V _{CM} = 0V to 1V	70	85	-	74	85	-	dB
		V _{CM} = 0V to 2.5V	50	55	-	50	55	-	dB
Common Mode Input Voltage Range	V _{ICR+}		2.5	3	-	2.5	3	-	V
	V _{ICR-}		-	-0.5	0	-	-0.5	0	V
Power Supply Rejection Ratio	PSRR	ΔV+ = 1V; ΔV- = 1V	70	84	-	75	84	-	dB
Large Signal Voltage Gain (Note 6)	A _{OL}	R _L = ∞, V _O = 0.5V to 4V	-	111	-	-	113	-	dB
		R _L = 10kΩ, V _O = 0.5V to 3.6V	80	86	-	83	86	-	dB
Source Current	I _{SOURCE}	V _O = 0V	1.75	2.2	-	1.75	2.2	-	mA
Sink Current	I _{SINK}	V _O = 5V	1.70	2	-	1.70	2	-	mA

Electrical Specifications $T_A = +25^\circ\text{C}$, $V_+ = 5\text{V}$, $V_- = 0\text{V}$ (Continued)

PARAMETER	SYMBOL	TEST CONDITIONS	CA5260			CA5260A			UNITS
			MIN	TYP	MAX	MIN	TYP	MAX	
Output Voltage	V_{OM+}	$R_L = \infty$	4.99	5	-	4.99	5	-	V
	V_{OM-}		-	0	0.01	-	0	0.01	V
	V_{OM+}	$R_L = 10\text{k}\Omega$	4.4	4.7	-	4.4	4.7	-	V
	V_{OM-}		-	0	0.01	-	0	0.01	V
	V_{OM+}	$R_L = 2\text{k}\Omega$	3	3.4	-	3	3.4	-	V
	V_{OM-}		-	0	0.01	-	0	0.01	V
Supply Current	I_{SUPPLY}	$V_O = 0\text{V}$	-	1.60	2.0	-	1.60	2.0	mA
		$V_O = 2.5\text{V}$	-	1.80	2.25	-	1.80	2.25	mA

NOTE:

6. For $V_+ = 4.5\text{V}$ and $V_- = \text{GND}$; $V_{OUT} = 0.5\text{V}$ to 3.2V at $R_L = 10\text{k}\Omega$.**Electrical Specifications** $T_A = -55^\circ\text{C}$ to $+125^\circ\text{C}$, $V_+ = 5\text{V}$, $V_- = 0\text{V}$

PARAMETER	SYMBOL	TEST CONDITIONS	CA5260			CA5260A			UNITS
			MIN (Note 8)	TYP	MAX (Note 8)	MIN (Note 8)	TYP	MAX (Note 8)	
Input Offset Voltage	V_{IO}	$V_O = 2.5\text{V}$	-	3	20	-	2	15	mV
Input Offset Current	I_{IO}	$V_O = 2.5\text{V}$	-	1	10	-	1	10	nA
Input Current	I_I	$V_O = 2.5\text{V}$	-	2	15	-	2	15	nA
Common Mode Rejection Ratio	CMRR	$V_{CM} = 0$ to 1V	60	78	-	65	78	-	dB
		$V_{CM} = 0$ to 2.5V	50	60	-	50	60	-	dB
Common Mode Input Voltage Range	V_{ICR+}		2.5	3	-	2.5	3	-	V
	V_{ICR-}		-	-0.5	0	-	-0.5	0	V
Power Supply Rejection Ratio	PSRR	$\Delta V_+ = 1\text{V}$; $\Delta V_- = 1\text{V}$	60	65	-	62	65	-	dB
Large Signal Voltage Gain (Note 7)	A_{OL}	$R_L = \infty$, $V_O = 0.5$ to 4V	70	78	-	70	78	-	dB
		$R_L = 10\text{k}\Omega$, $V_O = 0.5$ to 3.6V	60	65	-	60	65	-	dB
Source Current	I_{SOURCE}	$V_O = 0\text{V}$	1.3	1.6	-	1.3	1.6	-	mA
Sink Current	I_{SINK}	$V_O = 5\text{V}$	1.2	1.4	-	1.2	1.4	-	mA
Output Voltage	V_{OM+}	$R_L = \infty$	4.99	5	-	4.99	5	-	V
	V_{OM-}		-	0	0.01	-	0	0.01	V
	V_{OM+}	$R_L = 10\text{k}\Omega$	4.2	4.4	-	4.2	4.4	-	V
	V_{OM-}		-	0	0.01	-	0	0.01	V
	V_{OM+}	$R_L = 2\text{k}\Omega$	2.5	2.7	-	2.5	2.7	-	V
	V_{OM-}		-	0	0.01	-	0	0.01	V
Supply Current	I_{SUPPLY}	$V_O = 0\text{V}$	-	1.65	2.2	-	1.65	2.2	mA
		$V_O = 2.5\text{V}$	-	1.95	2.35	-	1.95	2.35	mA

NOTES:

7. For $V_+ = 4.5\text{V}$ and $V_- = \text{GND}$; $V_{OUT} = 0.5\text{V}$ to 3.2V at $R_L = 10\text{k}\Omega$.8. Parameters with MIN and/or MAX limits are 100% tested at $+25^\circ\text{C}$, unless otherwise specified. Temperature limits established by characterization and are not production tested.

Electrical Specifications Each Amplifier at $T_A = +25^\circ\text{C}$, $V_+ = 15\text{V}$, $V_- = 0\text{V}$, Unless Otherwise Specified

PARAMETER	SYMBOL	TEST CONDITIONS	CA5260			CA5260A			UNITS
			MIN	TYP	MAX	MIN	TYP	MAX	
Input Offset Voltage	V_{IO}	$V_S = \pm 7.5$	-	6	15	-	2	5	mV
Input Offset Current	I_{IO}	$V_S = \pm 7.5$	-	0.5	30	-	0.5	20	μA
Input Current	I_I	$V_S = \pm 7.5$	-	5	50	-	5	30	μA
Large Signal Voltage Gain	A_{OL}	$V_O = 10V_{P-P}$ $R_L = 10k\Omega$	40	320	-	40	320	-	kV/V
			92	110	-	92	110	-	dB
Common Mode Rejection Ratio	CMRR		70	90	-	80	95	-	dB
Common Mode Input Voltage Range	V_{ICR}		10	-0.5 to 12	0	10	-0.5 to 12	0	V
Power Supply Rejection Ratio, $\Delta V_{IO} / \Delta V_{\pm}$	PSRR	$V_S = \pm 7.5$	-	32	320	-	32	150	$\mu\text{V/V}$
Maximum Output Voltage	V_{OM+}	$R_L = 10k\Omega$	11	13.3	-	11	13.3	-	V
	V_{OM-}		-	0.002	0.01	-	0.002	0.01	V
	V_{OM+}	$R_L = \infty$	14.99	15	-	14.99	15	-	V
	V_{OM-}		-	0	0.01	-	0	0.01	V
Maximum Output Current	I_{OM+} (Source)	$V_O = 7.5\text{V}$	12	22	45	12	22	45	mA
	I_{OM-} (Sink)		12	20	45	12	20	45	mA
Total Supply Current, $R_L = \infty$	I+	V_O (Amp A) = 7.5V V_O (Amp B) = 7.5V	-	9	16.5	-	9	16.5	mA
		V_O (Amp A) = 0V V_O (Amp B) = 0V	-	1.2	4	-	1.2	4	mA
		V_O (Amp A) = 0V V_O (Amp B) = 7.5V	-	5	9.5	-	5	9.5	mA
Input Offset Voltage Temperature Drift	$\Delta V_{IO} / \Delta T$		-	8	-	-	6	-	$\mu\text{V}/^\circ\text{C}$
Crosstalk		f = 1kHz	-	120	-	-	120	-	dB

Schematic Diagram

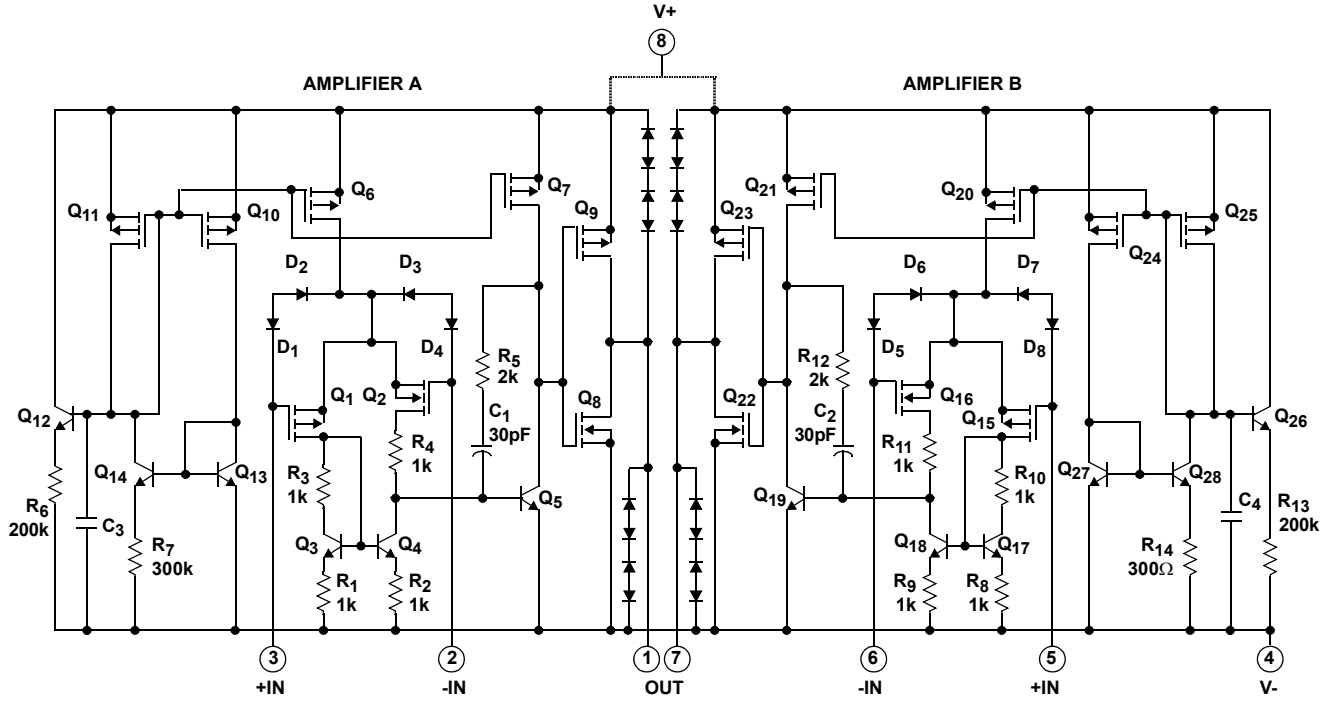

Small Outline Plastic Packages (SOIC)

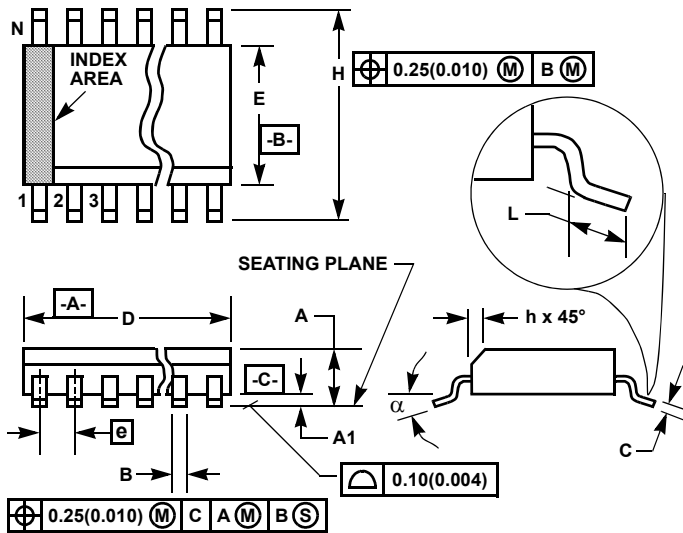

**M8.15 (JEDEC MS-012-AA ISSUE C)
8 LEAD NARROW BODY SMALL OUTLINE PLASTIC PACKAGE**

SYMBOL	INCHES		MILLIMETERS		NOTES
	MIN	MAX	MIN	MAX	
A	0.0532	0.0688	1.35	1.75	-
A1	0.0040	0.0098	0.10	0.25	-
B	0.013	0.020	0.33	0.51	9
C	0.0075	0.0098	0.19	0.25	-
D	0.1890	0.1968	4.80	5.00	3
E	0.1497	0.1574	3.80	4.00	4
e	0.050 BSC		1.27 BSC		-
H	0.2284	0.2440	5.80	6.20	-
h	0.0099	0.0196	0.25	0.50	5
L	0.016	0.050	0.40	1.27	6
N	8		8		7
α	0°	8°	0°	8°	-

NOTES:

1. Symbols are defined in the "MO Series Symbol List" in Section 2.2 of Publication Number 95.
2. Dimensioning and tolerancing per ANSI Y14.5M-1982.
3. Dimension "D" does not include mold flash, protrusions or gate burrs. Mold flash, protrusion and gate burrs shall not exceed 0.15mm (0.006 inch) per side.
4. Dimension "E" does not include interlead flash or protrusions. Interlead flash and protrusions shall not exceed 0.25mm (0.010 inch) per side.
5. The chamfer on the body is optional. If it is not present, a visual index feature must be located within the crosshatched area.
6. "L" is the length of terminal for soldering to a substrate.
7. "N" is the number of terminal positions.
8. Terminal numbers are shown for reference only.
9. The lead width "B", as measured 0.36mm (0.014 inch) or greater above the seating plane, shall not exceed a maximum value of 0.61mm (0.024 inch).
10. Controlling dimension: MILLIMETER. Converted inch dimensions are not necessarily exact.

Rev. 1 6/05

© Copyright Intersil Americas LLC 2003-2010. All Rights Reserved.
All trademarks and registered trademarks are the property of their respective owners.

For additional products, see www.intersil.com/en/products.html

Intersil products are manufactured, assembled and tested utilizing ISO9001 quality systems as noted in the quality certifications found at www.intersil.com/en/support/qualandreliability.html

Intersil products are sold by description only. Intersil may modify the circuit design and/or specifications of products at any time without notice, provided that such modification does not, in Intersil's sole judgment, affect the form, fit or function of the product. Accordingly, the reader is cautioned to verify that datasheets are current before placing orders. Information furnished by Intersil is believed to be accurate and reliable. However, no responsibility is assumed by Intersil or its subsidiaries for its use; nor for any infringements of patents or other rights of third parties which may result from its use. No license is granted by implication or otherwise under any patent or patent rights of Intersil or its subsidiaries.

For information regarding Intersil Corporation and its products, see www.intersil.com

Looking for pricing, stock, or lifecycle information?

Click below to explore more details on WIN SOURCE:

 [View CA5260AM96 on WIN SOURCE](#)

 [Intersil Information](#)

Optimize Your Supply Chain with WIN SOURCE Solutions

-  Global Sourcing Solution
-  Obsolete Management
-  Cost Control Management
-  Shortage Management
-  Alternative Solution
-  Excess Inventory Management