

# LT1Z□95A series

## 3528 Size, 1.9mm Thickness, Leadless Chip LED

### Outline Dimensions

(Unit : mm)

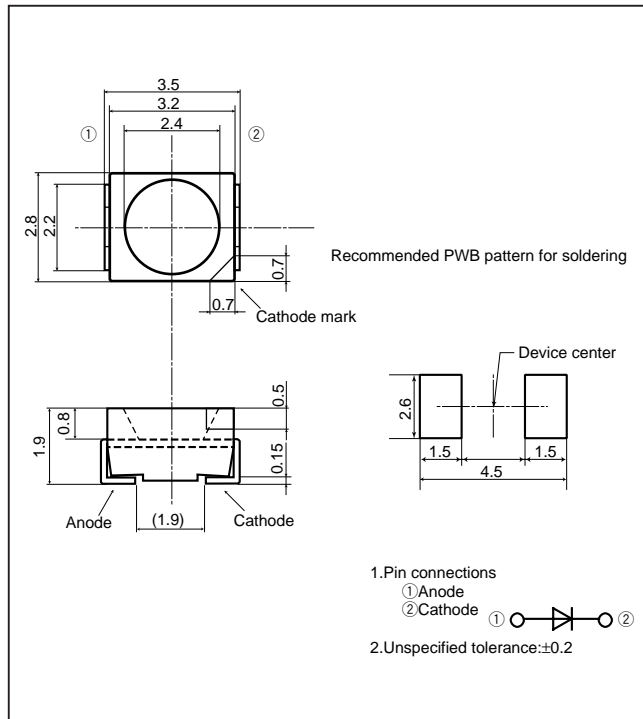

### Directive Characteristics

(Ta=25°C)

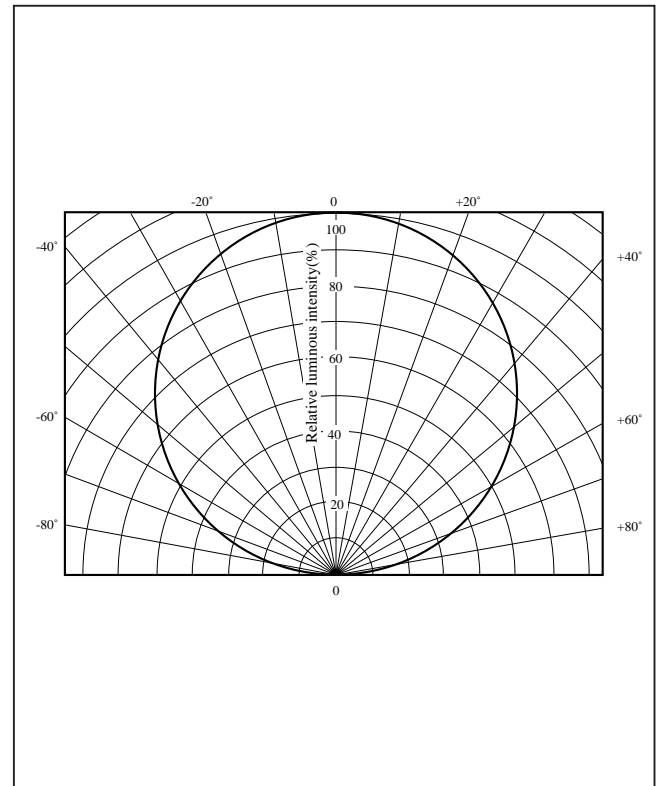

### Absolute Maximum Ratings

(Ta=25°C)

Model No.	Emitting color	Material	Power dissipation P (mW)	Forward current IF (mA)	Peak forward current IFM*1 (mA)	Derating factor (mA/°C)		Reverse voltage VR (V)	Operating temperature Topr (°C)	Storage temperature Tstg (°C)	Soldering temperature Tsol*2 (°C)
						DC	Pulse				
GM5ZR95200AE	Red	AlGaInP on GaAs	78	30	60	0.60	1.20	5	-55 to +110	-55 to +110	295
LT1ZJ95A	Orange	AlGaInP on GaAs	78	30	60	0.60	1.20	5	-55 to +110	-55 to +110	295
LT1ZS95A	Sunset orange	AlGaInP on GaAs	78	30	60	0.60	1.20	5	-55 to +110	-55 to +110	295
LT1ZV95A	Amber	AlGaInP on GaAs	78	30	60	0.60	1.20	5	-55 to +110	-55 to +110	295
LT1ZE95A	Yellow-green	AlGaInP on GaAs	78	30	60	0.60	1.20	5	-55 to +110	-55 to +110	295
LT1ZG95A	Green	AlGaInP on GaAs	78	30	60	0.60	1.20	5	-55 to +110	-55 to +110	295

\*1 Duty ratio=1/10, Pulse width=0.1ms

\*2 For 3s or less at the temperature of hand soldering. Temperature of reflow soldering is shown on page 2.

### Electro-optical Characteristics

(IF=20mA, Ta=25°C)

Lens type	Model No.	Forward voltage VF(V)		Peak emission wavelength λp(nm) TYP	Dominant wavelength λd(nm) TYP	Luminous intensity IV(mcd) TYP	Reverse current		Terminal capacitance		Page for characteristics diagrams
		TYP	MAX				IR(μA) MAX	VR (V)	Ct(pF) TYP	(MHz)	
Colorless transparency	GM5ZR95200AE	2.0	2.6	638	630	100	100	4	60	1	64
	LT1ZJ95A	2.2	2.6	627	618	200	100	4	60	1	64
	LT1ZS95A	2.2	2.6	609	605	290	100	4	60	1	64
	LT1ZV95A	2.2	2.6	591	588	170	100	4	60	1	64
	LT1ZE95A	2.2	2.6	570	570	45	100	4	60	1	64
	LT1ZG95A	2.2	2.6	560	560	15	100	4	60	1	64

Super/High-Luminosity [Single Color]

# Characteristics Diagrams

## GM5Y□01210A series

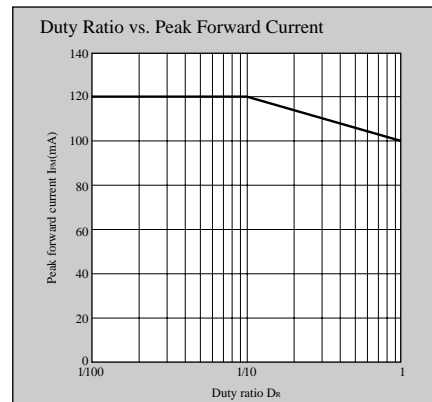
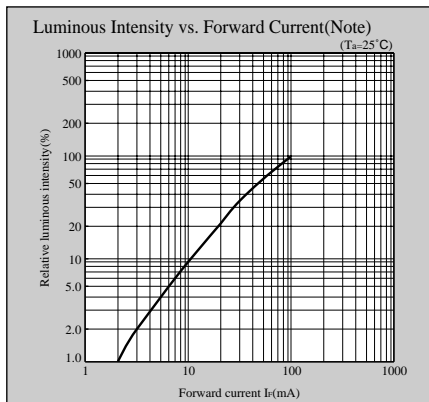
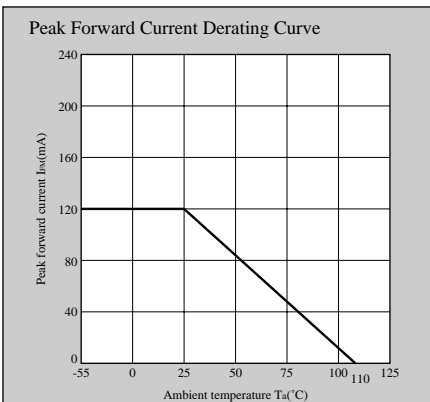
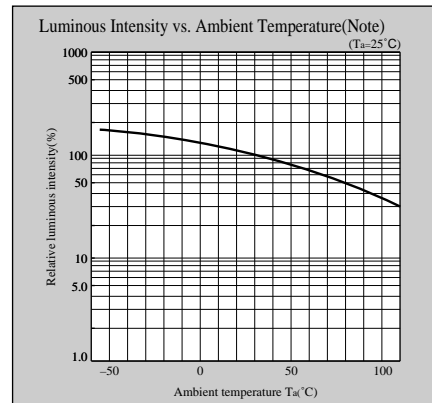
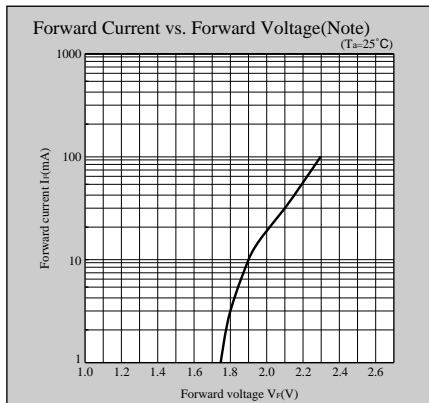
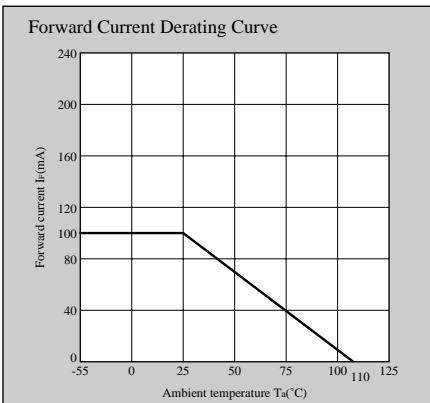

## LT1Z□95A series

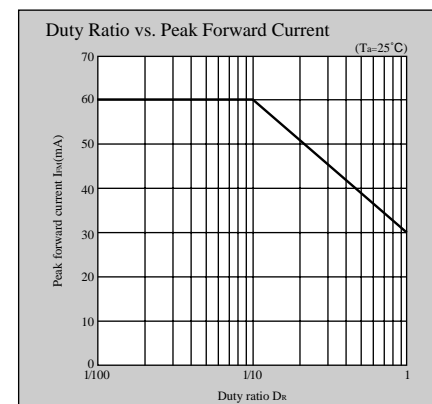
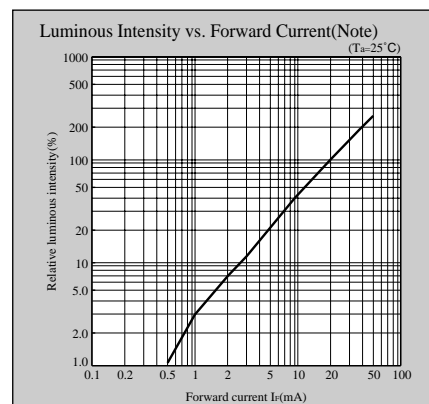
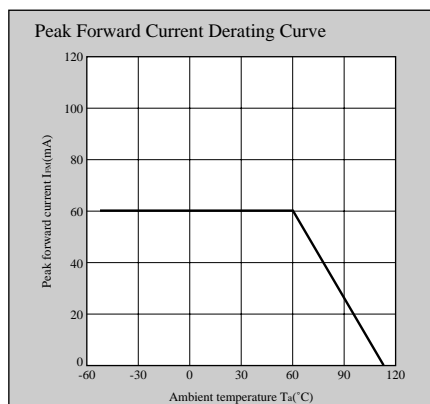
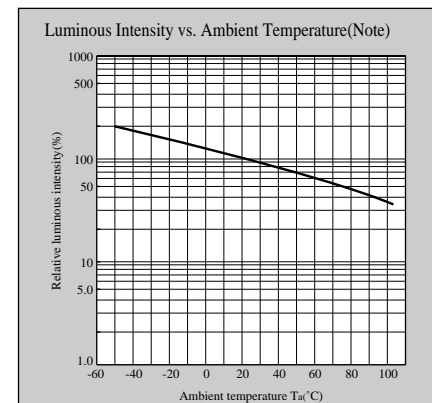
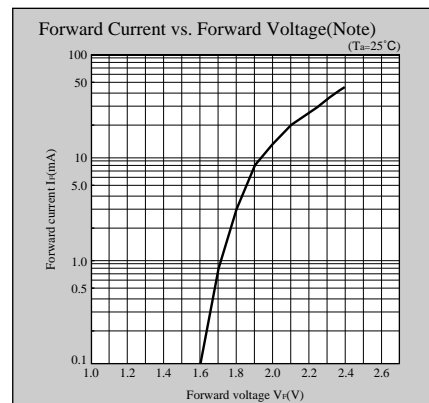
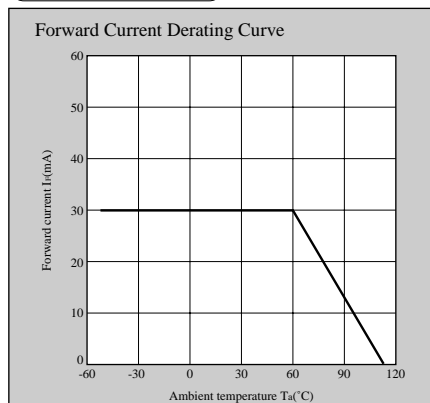

Note) Characteristics shown in diagrams are typical values. (not assurance value)

# Taping Specifications

(Unit : mm)

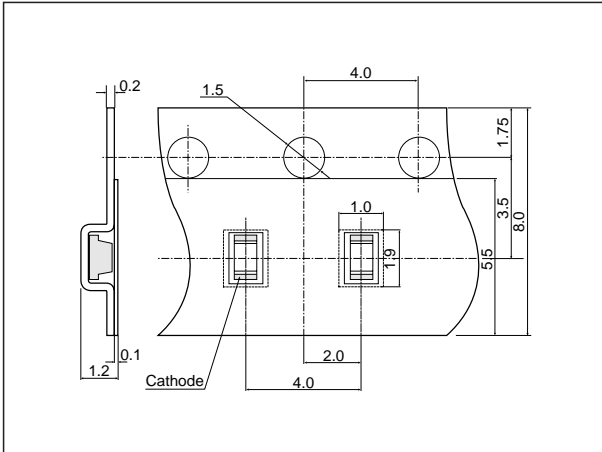

GM1□□35200A□ series 6 000 pcs. /reel  
 GM1□□55200A□ series 5 000 pcs. /reel  
 LT1□□67A series 4 000 pcs. /reel  
 LT1□97A series 5 000 pcs. /reel

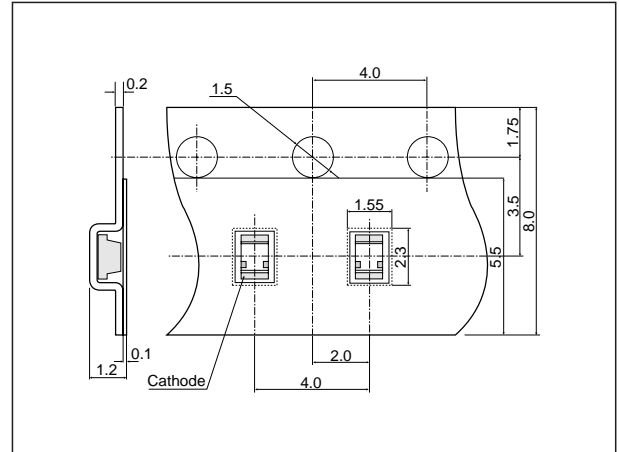

GM1□□40300AE series/LT1□□40A series 4 000 pcs. /reel

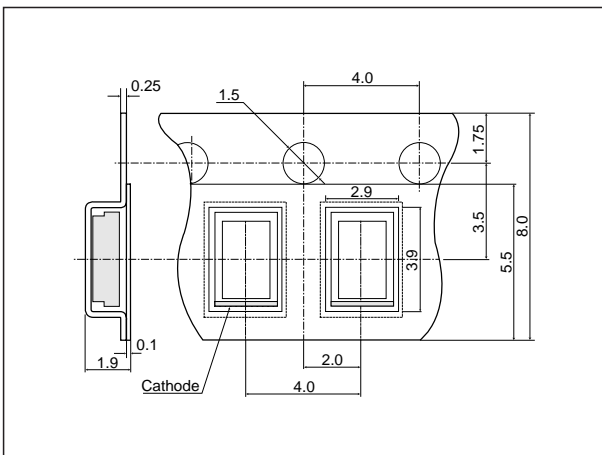

LT1□90A series 3 000 pcs. / reel

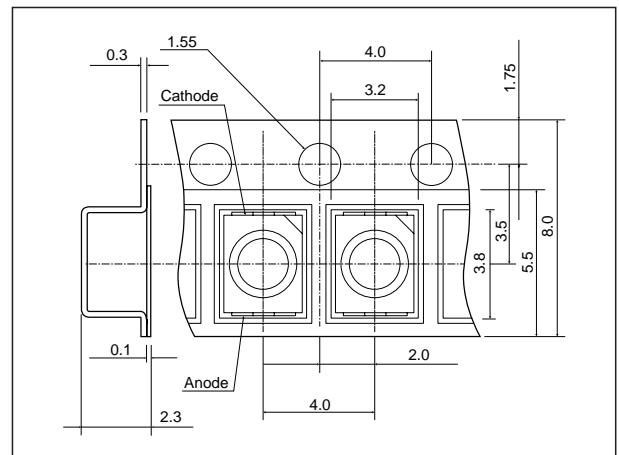

GM5□□95200A□ series/LT1Z□95A series 2 000 pcs. /reel

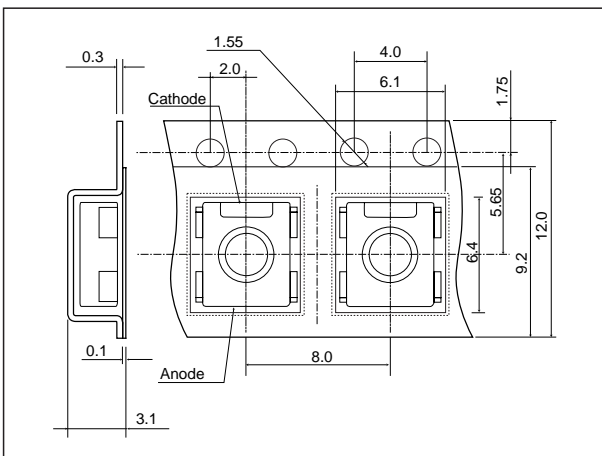

GM5□□01200A series/GM5WA02200A/GM5WA06210A/  
 GM5WA06250A 800 pcs. / reel

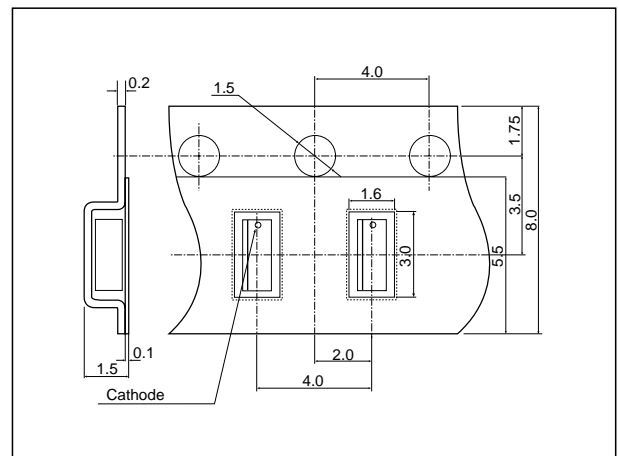

LT1□□45A series/GM4□C13300AC series 3 000 pcs. /reel

# Taping Specifications

(Unit : mm)

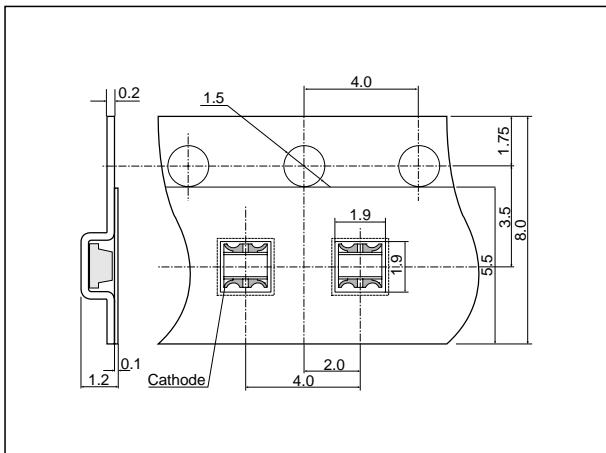

LT1□□67A series/GM1WA80350A/GM1ZUB 80300A/GM1ZSG80300A  
4 000 pcs./reel

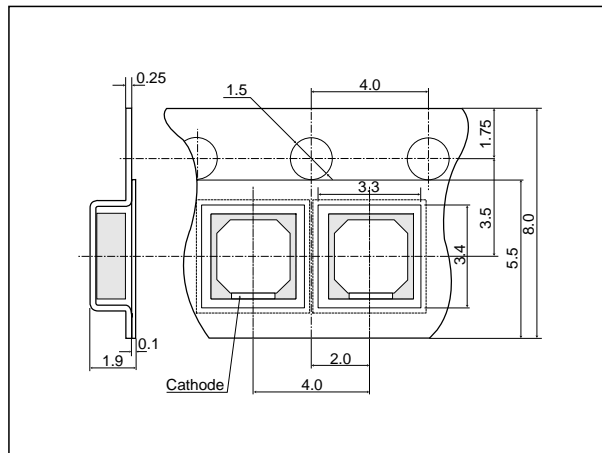

LT1□□90A series 3 000 pcs./reel

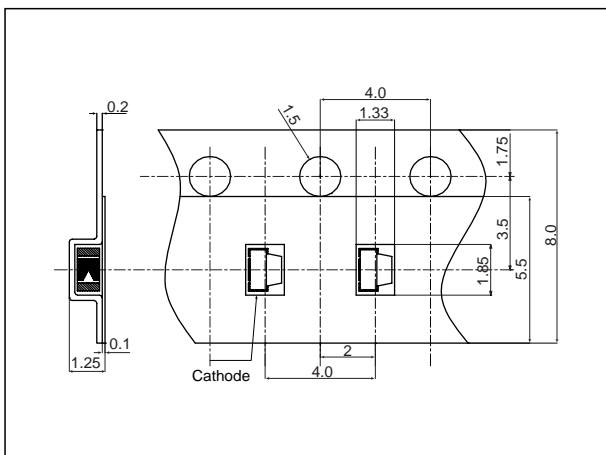

GM4□□81200A series 4 000 pcs./reel

## ■ Shape and dimension of reel

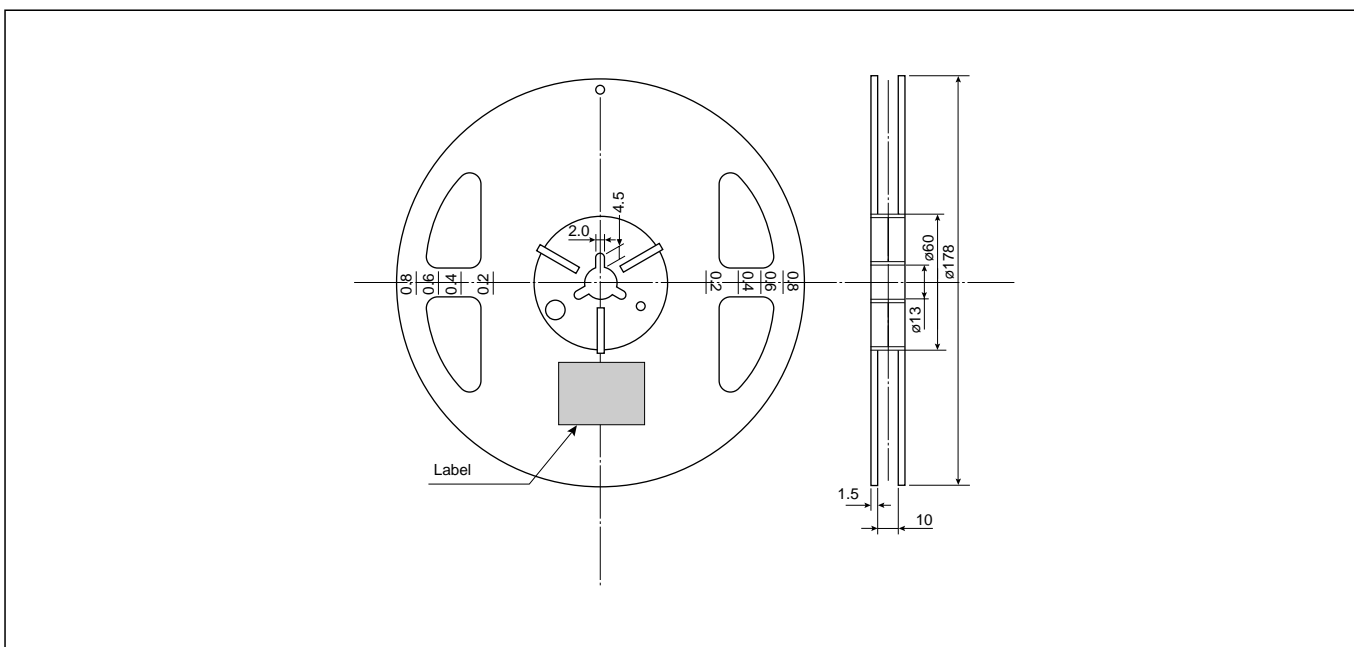

# Taping Specifications

## ■Lead type Chip LED (Unit : mm)

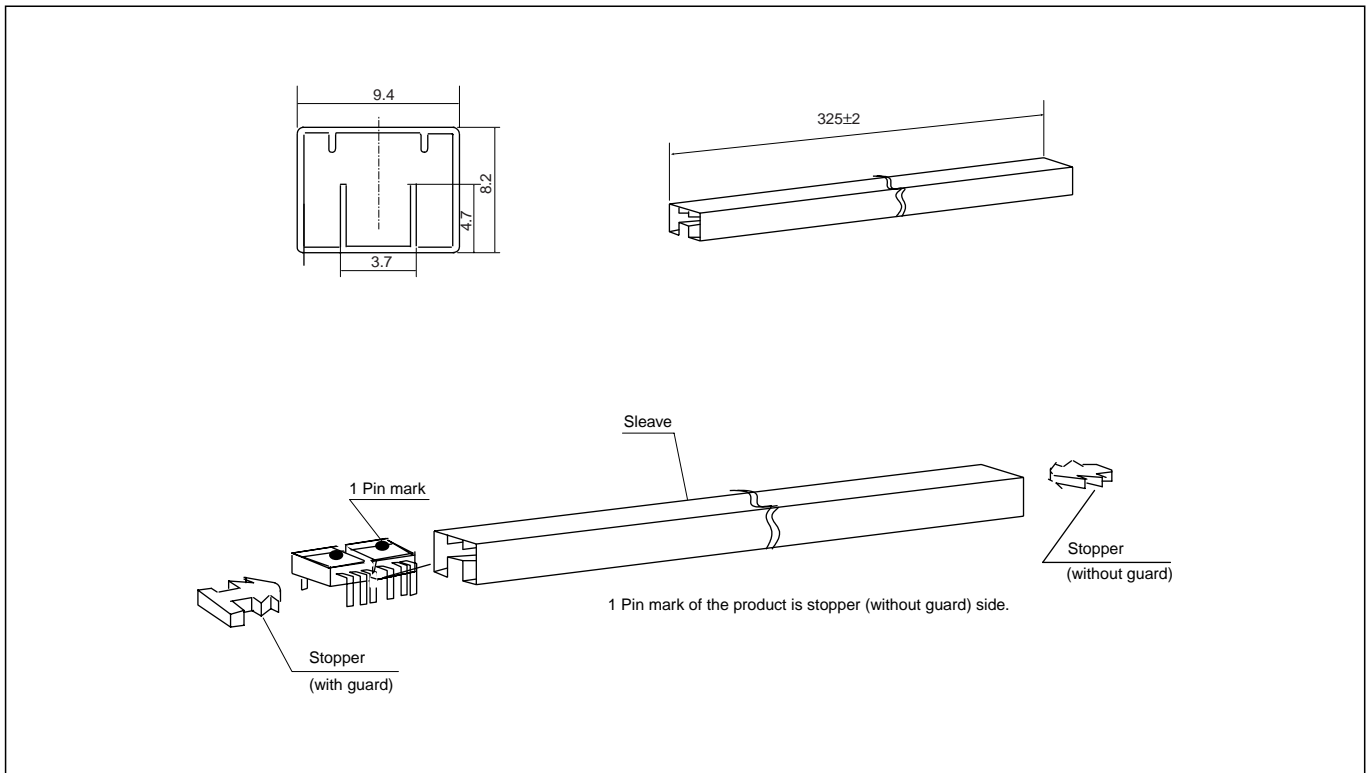

GM5□□03200Z series/GM5WA06200Z/GM5WA06250Z 1 000 pcs. (50 pcs./sleeve × 20)

## NOTICE

- The circuit application examples in this publication are provided to explain representative applications of SHARP devices and are not intended to guarantee any circuit design or license any intellectual property rights. SHARP takes no responsibility for any problems related to any intellectual property right of a third party resulting from the use of SHARP's devices.
- Contact SHARP in order to obtain the latest device specification sheets before using any SHARP device. SHARP reserves the right to make changes in the specifications, characteristics, data, materials, structure, and other contents described herein at any time without notice in order to improve design or reliability. Manufacturing locations are also subject to change without notice.
- Observe the following points when using any devices in this publication. SHARP takes no responsibility for damage caused by improper use of the devices which does not meet the conditions and absolute maximum ratings to be used specified in the relevant specification sheet nor meet the following conditions:
  - (i) The devices in this publication are designed for use in general electronic equipment designs such as:
    - Personal computers
    - Office automation equipment
    - Telecommunication equipment [terminal]
    - Test and measurement equipment
    - Industrial control
    - Audio visual equipment
    - Consumer electronics
  - (ii) Measures such as fail-safe function and redundant design should be taken to ensure reliability and safety when SHARP devices are used for or in connection with equipment that requires higher reliability such as:
    - Transportation control and safety equipment (i.e., aircraft, trains, automobiles, etc.)
    - Traffic signals
    - Gas leakage sensor breakers
    - Alarm equipment
    - Various safety devices, etc.
  - (iii) SHARP devices shall not be used for or in connection with equipment that requires an extremely high level of reliability and safety such as:
    - Space applications
    - Telecommunication equipment [trunk lines]
    - Nuclear power control equipment
    - Medical and other life support equipment (e.g., scuba).
- If the SHARP devices listed in this publication fall within the scope of strategic products described in the Foreign Exchange and Foreign Trade Law of Japan, it is necessary to obtain approval to export such SHARP devices.
- This publication is the proprietary product of SHARP and is copyrighted, with all rights reserved. Under the copyright laws, no part of this publication may be reproduced or transmitted in any form or by any means, electronic or mechanical, for any purpose, in whole or in part, without the express written permission of SHARP. Express written permission is also required before any use of this publication may be made by a third party.
- Contact and consult with a SHARP representative if there are any questions about the contents of this publication.

## Looking for pricing, stock, or lifecycle information?

Click below to explore more details on WIN SOURCE:

- ⊖ [View GM5ZR95200AE](#) on WIN SOURCE
- ⊖ [Sharp Microelectronics](#) Information

## Optimize Your Supply Chain with WIN SOURCE Solutions

- ✓ Global Sourcing Solution
- ✓ Obsolete Management
- ✓ Cost Control Management
- ✓ Shortage Management
- ✓ Alternative Solution
- ✓ Excess Inventory Management