



**THE DATASHEET OF
SN65LVDS047PWRG4**



LVDS QUAD DIFFERENTIAL LINE DRIVER

FEATURES

- >400 Mbps (200 MHz) Signaling Rates
- Flow-Through Pinout Simplifies PCB Layout
- 300 ps Maximum Differential Skew
- Propagation Delay Times 1.8 ns (Typical)
- 3.3 V Power Supply Design
- ±350 mV Differential Signaling
- High Impedance on LVDS Outputs on Power Down
- Conforms to TIA/EIA-644 LVDS Standard
- Industrial Operating Temperature Range (-40°C to 85°C)
- Available in SOIC and TSSOP Packages

The SN65LVDS047 is characterized for operation from -40°C to 85°C.

D OR PW PACKAGE
(Marked as LVDS047)
(TOP VIEW)

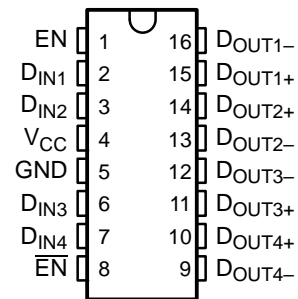

DESCRIPTION

The SN65LVDS047 is a quad differential linedriver that implements the electrical characteristics of low-voltage differential signaling (LVDS). This signaling technique lowers the output voltage levels of 5-V differential standard levels (such as EIA/TIA-422B) to reduce the power, increase the switching speeds, and allow operation with a 3.3-V supply rail. Any of the four current-mode drivers will deliver a minimum differential output voltage magnitude of 247 mV into a 100-Ω load when enabled.

The intended application of this device and signaling technique is for point-to-point and multi-drop baseband data transmission over controlled impedance media of approximately 100 Ω. The transmission media may be printed-circuit board traces, backplanes, or cables. The ultimate rate and distance of data transfer is dependent upon the attenuation characteristics of the media, the noise coupling to the environment, and other system characteristics.

functional block diagram

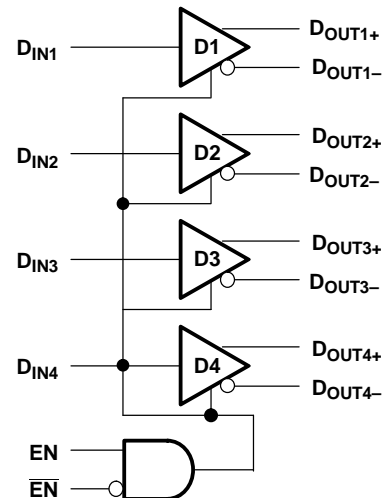

TRUTH TABLE⁽¹⁾

INPUT	ENABLES		OUTPUTS	
	D _{IN}	EN	EN̄	D _{OUT+}
L	H	L or OPEN	L	H
H			H	L
X	All other conditions		Z	Z

(1) H = high level, L = low level, X = irrelevant, Z = high impedance (off)



Please be aware that an important notice concerning availability, standard warranty, and use in critical applications of Texas Instruments semiconductor products and disclaimers thereto appears at the end of this data sheet.



These devices have limited built-in ESD protection. The leads should be shorted together or the device placed in conductive foam during storage or handling to prevent electrostatic damage to the MOS gates.

EQUIVALENT INPUT AND OUTPUT SCHEMATIC DIAGRAMS

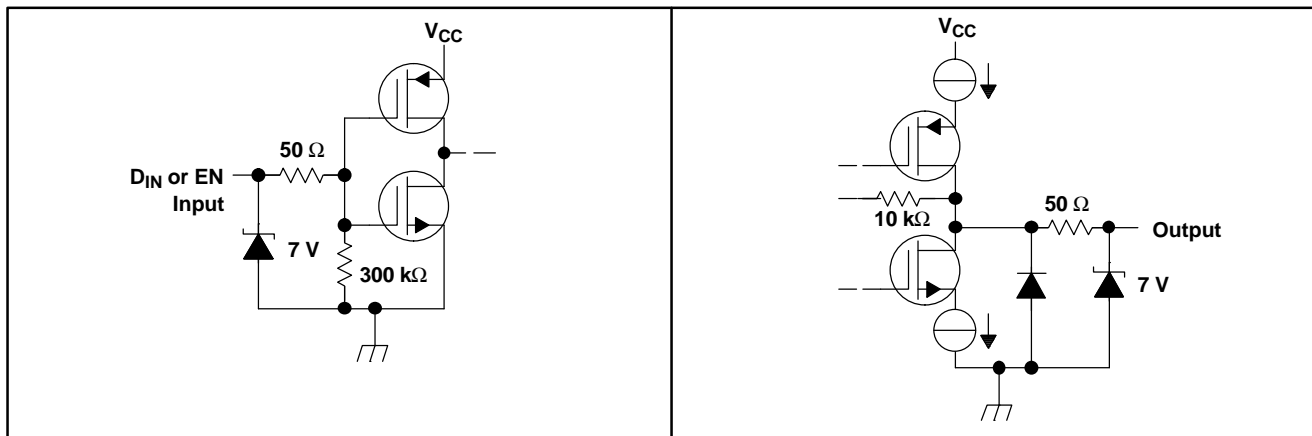

ABSOLUTE MAXIMUM RATINGS⁽¹⁾

over operating free-air temperature (see ⁽²⁾ range (unless otherwise noted)

		UNIT
(V _{CC})	Supply voltage	-0.3 V to 4 V
V _I (D _{IN})	Input voltage range	-0.3 V to (V _{CC} +0.3 V)
(EN, $\overline{\text{EN}}$)	Enable input voltage	-0.3 V to (V _{CC} +0.3 V)
V _O (D _{OUT+} , D _{OUT-})	Output voltage	-0.5 V to (V _{CC} +0.5 V)
(D _{OUT+} , D _{OUT-})	Bus-pin--electrostatic discharge, see ⁽³⁾	>10 kV
(D _{OUT+} , (D _{OUT-})	Short circuit duration	Continuous
	Storage temperature range	-65°C to 150°C
	Lead temperature 1,6 mm (1/16 inch) from case for 10 seconds	260°C

- (1) Stresses beyond those listed under absolute maximum ratings may cause permanent damage to the device. These are stress ratings only, and functional operation of the device at these or any other conditions beyond those indicated under recommended operating conditions is not implied. Exposure to absolute-maximum-rated conditions for extended periods may affect device reliability.
- (2) All voltage values, except differential I/O bus voltages, are with respect to network ground terminal.
- (3) Tested in accordance with MIL-STD-883C Method 3015.7.

DISSIPATION RATING TABLE

PACKAGE	T _A ≤ 25°C POWER RATING	OPERATING FACTOR ⁽¹⁾ ABOVE T _A = 25°C	T _A = 85°C POWER RATING
D	950 mW	7.6 mW/°C	494 mW
PW	774 mW	6.2 mW/°C	402 mW

- (1) This is the inverse of the junction-to-ambient thermal resistance when board-mounted and with no air flow.

RECOMMENDED OPERATING CONDITIONS

		MIN	NOM	MAX	UNIT
V _{CC}	Supply voltage	3	3.3	3.6	V
T _A	Operating free-air temperature	-40	25	85	°C

ELECTRICAL CHARACTERISTICS

 over recommended operating free-air temperature range (see ⁽¹⁾ and ⁽²⁾) (unless otherwise noted)

PARAMETER		TEST CONDITIONS	MIN	TYP ⁽³⁾	MAX	UNIT
V_{OD}	Differential output voltage	$R_L = 100 \Omega$, see Figure 1	250	310	450	mV
$n V_{OD} $	Change in magnitude of V_{OD} for complementary output states			1	35	mV
$V_{OC(SS)}$	Steady-state, common-mode output voltage		1.125	1.17	1.375	V
$nV_{OC(SS)}$	Change in steady-state common-mode output voltage between logic states			1	25	mV
V_{OH}	Output high voltage			1.33	1.6	V
V_{OL}	Output low voltage		0.90	1.02		V
V_{IH}	Input high voltage				V_{CC}	V
V_{IL}	Input low voltage		GND	0.8	V	
I_{IH}	Input high current	$V_{IN} = V_{CC}$ or 2.5 V	-10	3	10	μ A
I_{IL}	Input low current	$V_{IN} = \text{GND}$ or 0.4 V	-10	1	10	μ A
V_{IK}	Input clamp voltage	$I_{CL} = -18 \text{ mA}$	-1.5	-0.8		V
I_{OS}	Output short circuit current, see ⁽⁴⁾	Enabled, $D_{IN} = V_{CC}$, $D_{OUT+} = 0 \text{ V}$ or $D_{IN} = \text{GND}$, $D_{OUT-} = 0 \text{ V}$		-3.1	-9	mA
I_{OSD}	Differential output short circuit current, see ⁽⁴⁾	Enabled, $V_{OD} = 0 \text{ V}$			-9	mA
I_{OFF}	Power-off leakage	$V_O = 0 \text{ V}$ or 3.6 V, $V_{CC} = 0 \text{ V}$ or Open	-1		1	μ A
I_{OZ}	Output 3-state current	$\overline{EN} = 0.8 \text{ V}$ and $\overline{EN} = 2 \text{ V}$, $V_O = 0 \text{ V}$ or V_{CC}	-1		1	μ A
I_{CC}	No load supply current, drivers enabled	$D_{IN} = V_{CC}$ or GND		7		mA
I_{CCL}	Loaded supply current, drivers enabled	$R_L = 100 \Omega$ all channels, $D_{IN} = V_{CC}$ or GND (all inputs)		20	26	mA
$I_{CC(Z)}$	No load supply current, drivers disabled	$D_{IN} = V_{CC}$ or GND, $\overline{EN} = \text{GND}$, $\overline{EN} = V_{CC}$		0.5	1.3	mA

- (1) Current into device pin is defined as positive. Current out of the device is defined as negative. All voltages are referenced to ground, unless otherwise specified.
- (2) The SN65LVDS047 is a current mode device and only functions within data sheet specifications when a resistive load is applied to the driver outputs, 90 Ω to 110 Ω typical range.
- (3) All typical values are given for: $V_{CC} = 3.3 \text{ V}$, $T_A = 25^\circ\text{C}$.
- (4) Output short circuit current (I_{OS}) is specified as magnitude only, minus sign indicates direction only.

SWITCHING CHARACTERISTICS

over recommended operating conditions (see ⁽¹⁾, ⁽²⁾ and ⁽³⁾)(unless otherwise noted)

PARAMETER		TEST CONDITIONS	MIN	TYP ⁽⁴⁾	MAX	UNIT
t_{PHL}	Differential propagation delay, high-to-low	$R_L = 100 \Omega$, $C_L = 15 \text{ pF}$, see Figure 2 and Figure 3	1.4	1.8	2.8	ns
t_{PLH}	Differential propagation delay, low-to-high		1.4	1.8	2.8	ns
$t_{SK(p)}$	Differential pulse skew ($t_{PHLD} - t_{PLHD}$), see ⁽⁵⁾			50	300	ps
$t_{SK(o)}$	Channel-to-channel skew, see ⁽⁶⁾			40	300	ps
$t_{SK(pp)}$	Differential part-to-part skew, see ⁽⁷⁾				1	ns
$t_{SK(lim)}$	Differential part-to-part skew, see ⁽⁸⁾				1.2	ns
t_r	Rise time			0.5	1.5	ns
t_f	Fall time			0.5	1.5	ns
t_{PHZ}	Disable time high to Z	$R_L = 100 \Omega$, $C_L = 15 \text{ pF}$, see Figure 4 and Figure 5		5.5	8	ns
t_{PLZ}	Disable time low to Z			5.5	8	ns
t_{PZH}	Enable time Z to high			8.5	12	ns
t_{PZL}	Enable time Z to low			8.5	12	ns
$f_{(MAX)}$	Maximum operating frequency, see ⁽⁹⁾			250		MHz

- (1) Generator waveform for all tests unless otherwise: $f = 1 \text{ MHz}$, $Z_o = 50 \Omega$, $t_r < 1 \text{ ns}$, and $t_f < 1 \text{ ns}$.
- (2) C_L includes probe and jig capacitance.
- (3) All input voltages are for one channel unless otherwise specified. Other inputs are set to GND.
- (4) All typical values are given for: $V_{CC} = 3.3 \text{ V}$, $T_A = 25^\circ\text{C}$.
- (5) $t_{SK(p)} |t_{PHL} - t_{PLH}|$ is the magnitude difference in differential propagation delay time between the positive going edge and the negative going edge of the same channel.
- (6) $t_{SK(o)}$ is the differential channel-to-channel skew of any event on the same device.
- (7) $t_{SK(pp)}$ is the differential part-to-part skew, and is defined as the difference between the minimum and the maximum specified differential propagation delays. This specification applies to devices at the same V_{CC} and within 5°C of each other within the operating temperature range.
- (8) $t_{SK(lim)}$ part-to-part skew, is the differential channel-to-channel skew of any event between devices. This specification applies to devices over recommended operating temperature and voltage ranges, and across process distribution. $t_{SK(lim)}$ is defined as $|\text{Min} - \text{Max}|$ differential propagation delay.
- (9) $f_{(MAX)}$ generator input conditions: $t_r = t_f < 1 \text{ ns}$ (0% to 100%), 50% duty cycle, 0 V to 3 V. Output criteria: duty cycle = 45% to 55%, $V_{OD} > 250 \text{ mV}$, all channels switching

PARAMETER MEASUREMENT INFORMATION

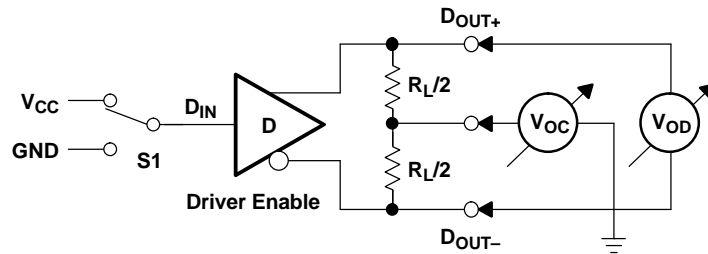

Figure 1. Driver V_{OD} and V_{OC} Test Circuit

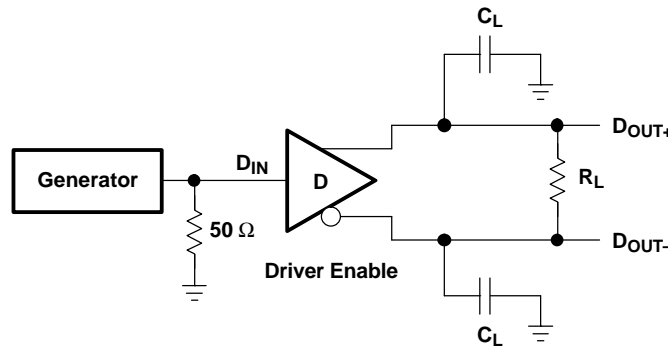

Figure 2. Driver Propagation Delay and Transition Time Test Circuit

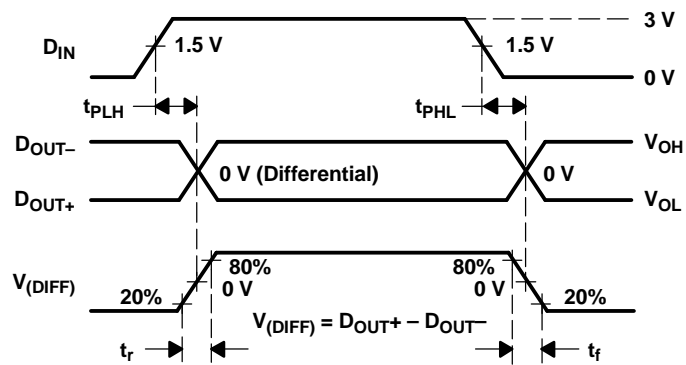

Figure 3. Driver Propagation Delay and Transition Time Waveforms

PARAMETER MEASUREMENT INFORMATION (continued)

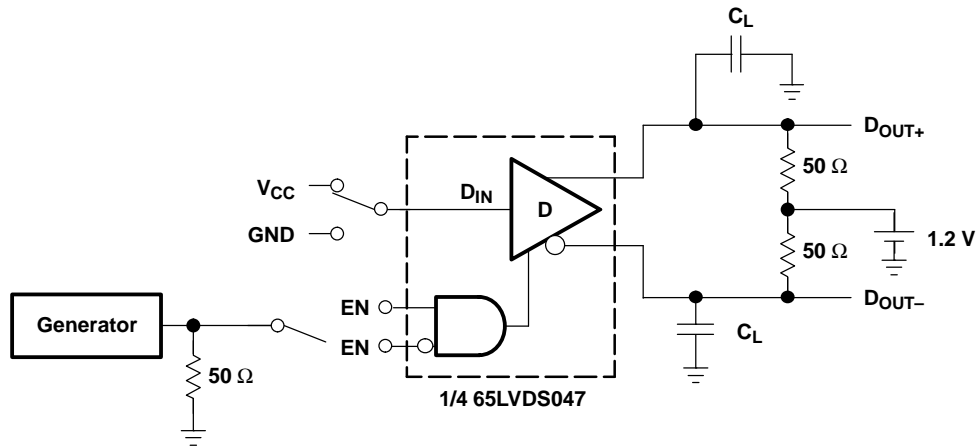

Figure 4. Driver 3-State Delay Test Circuit

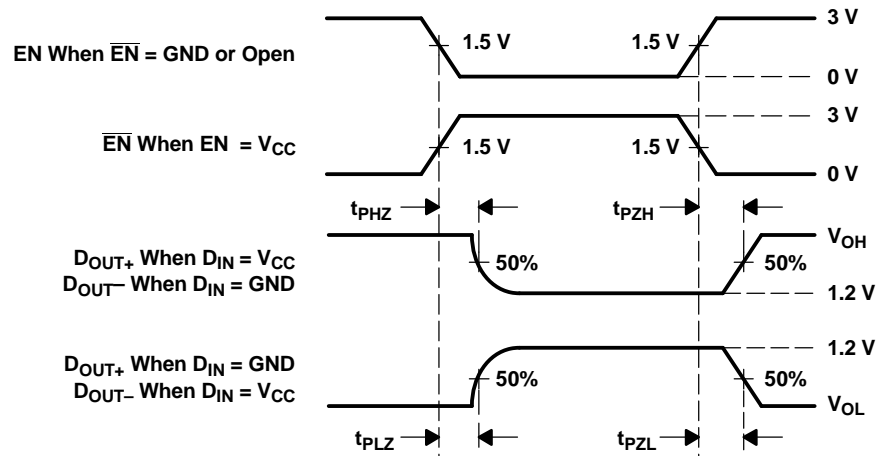

Figure 5. Driver 3-State Delay Waveform

TYPICAL CHARACTERISTICS

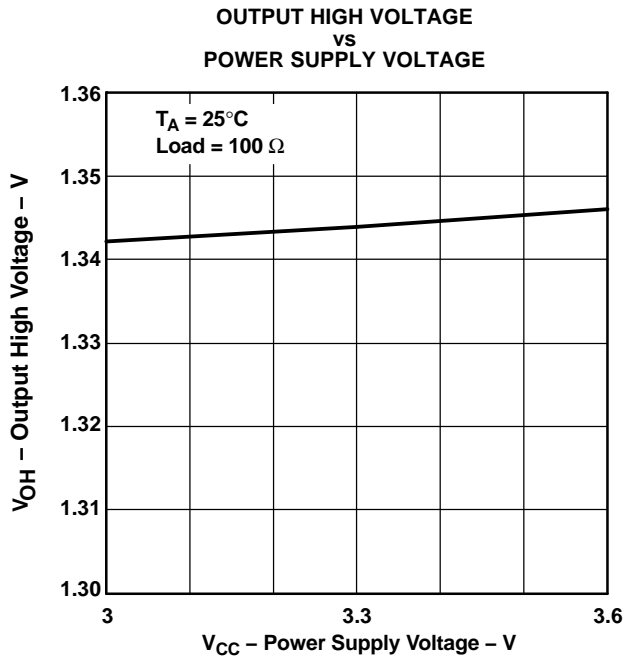

Figure 6.

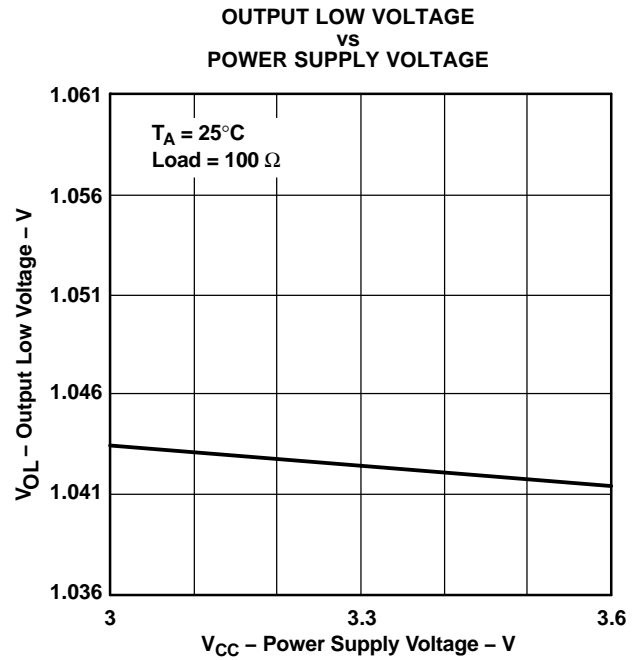

Figure 7.

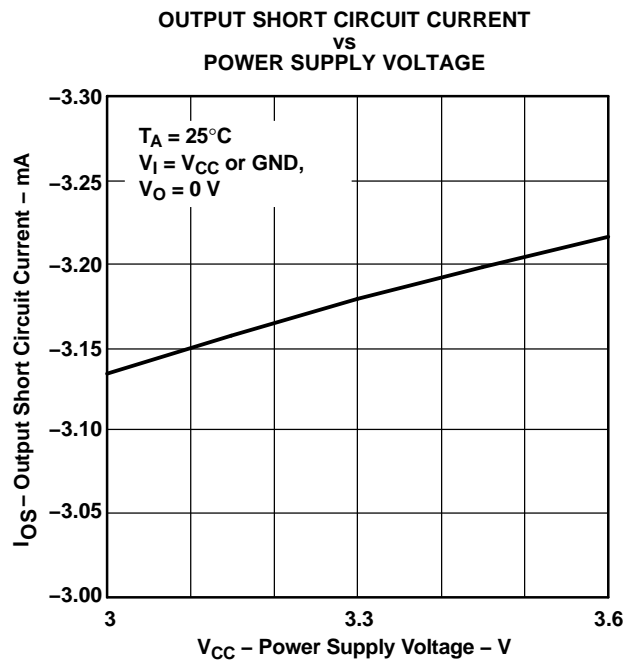

Figure 8.

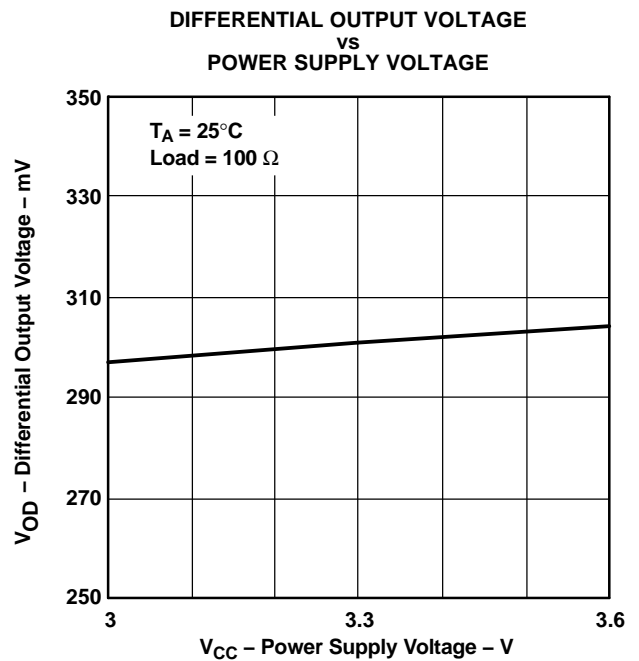

Figure 9.

TYPICAL CHARACTERISTICS (continued)

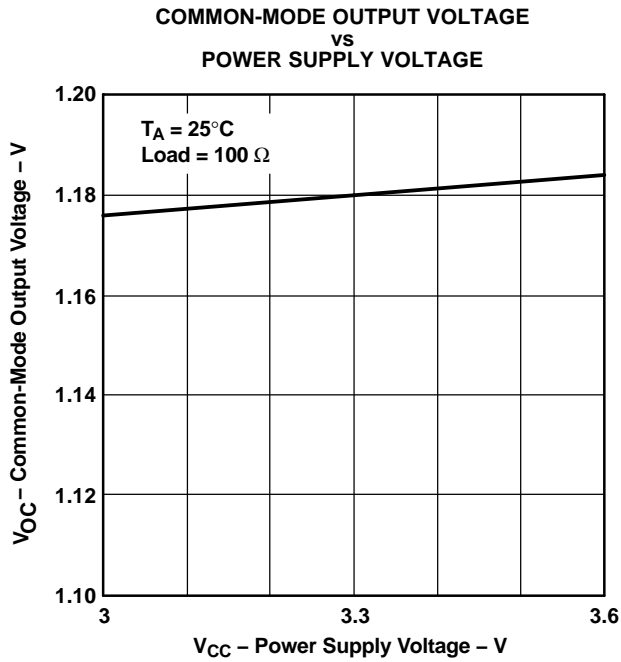

Figure 10.

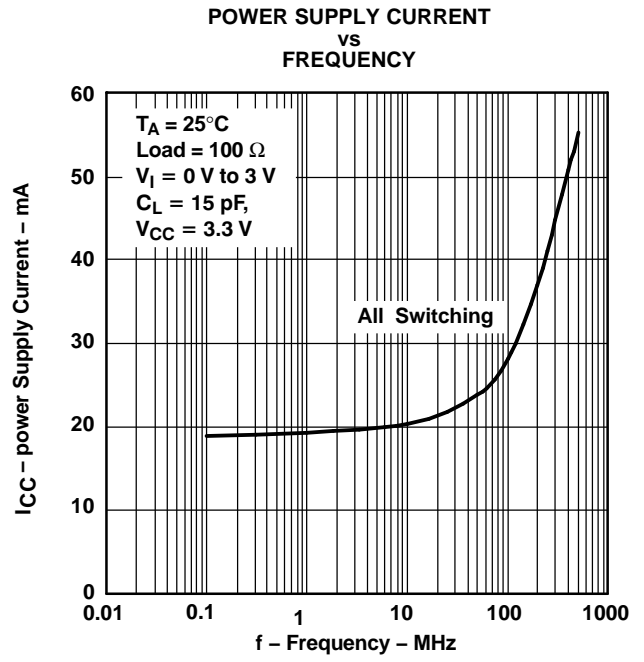

Figure 11.

PACKAGING INFORMATION

Orderable Device	Status (1)	Package Type	Package Drawing	Pins	Package Qty	Eco Plan (2)	Lead/Ball Finish (6)	MSL Peak Temp (3)	Op Temp (°C)	Device Marking (4/5)	Samples
SN65LVDS047D	ACTIVE	SOIC	D	16	40	Green (RoHS & no Sb/Br)	CU NIPDAU	Level-1-260C-UNLIM	-40 to 85	LVDS047	Samples
SN65LVDS047DG4	ACTIVE	SOIC	D	16	40	Green (RoHS & no Sb/Br)	CU NIPDAU	Level-1-260C-UNLIM	-40 to 85	LVDS047	Samples
SN65LVDS047DR	ACTIVE	SOIC	D	16	2500	Green (RoHS & no Sb/Br)	CU NIPDAU	Level-1-260C-UNLIM	-40 to 85	LVDS047	Samples
SN65LVDS047PW	ACTIVE	TSSOP	PW	16	90	Green (RoHS & no Sb/Br)	CU NIPDAU	Level-1-260C-UNLIM	-40 to 85	LVDS047	Samples
SN65LVDS047PWG4	ACTIVE	TSSOP	PW	16	90	Green (RoHS & no Sb/Br)	CU NIPDAU	Level-1-260C-UNLIM	-40 to 85	LVDS047	Samples
SN65LVDS047PWR	ACTIVE	TSSOP	PW	16	2000	Green (RoHS & no Sb/Br)	CU NIPDAU	Level-1-260C-UNLIM	-40 to 85	LVDS047	Samples
SN65LVDS047PWRG4	ACTIVE	TSSOP	PW	16	2000	Green (RoHS & no Sb/Br)	CU NIPDAU	Level-1-260C-UNLIM	-40 to 85	LVDS047	Samples

(1) The marketing status values are defined as follows:

ACTIVE: Product device recommended for new designs.

LIFEBUY: TI has announced that the device will be discontinued, and a lifetime-buy period is in effect.

NRND: Not recommended for new designs. Device is in production to support existing customers, but TI does not recommend using this part in a new design.

PREVIEW: Device has been announced but is not in production. Samples may or may not be available.

OBSOLETE: TI has discontinued the production of the device.

(2) Eco Plan - The planned eco-friendly classification: Pb-Free (RoHS), Pb-Free (RoHS Exempt), or Green (RoHS & no Sb/Br) - please check <http://www.ti.com/productcontent> for the latest availability information and additional product content details.

TBD: The Pb-Free/Green conversion plan has not been defined.

Pb-Free (RoHS): TI's terms "Lead-Free" or "Pb-Free" mean semiconductor products that are compatible with the current RoHS requirements for all 6 substances, including the requirement that lead not exceed 0.1% by weight in homogeneous materials. Where designed to be soldered at high temperatures, TI Pb-Free products are suitable for use in specified lead-free processes.

Pb-Free (RoHS Exempt): This component has a RoHS exemption for either 1) lead-based flip-chip solder bumps used between the die and package, or 2) lead-based die adhesive used between the die and leadframe. The component is otherwise considered Pb-Free (RoHS compatible) as defined above.

Green (RoHS & no Sb/Br): TI defines "Green" to mean Pb-Free (RoHS compatible), and free of Bromine (Br) and Antimony (Sb) based flame retardants (Br or Sb do not exceed 0.1% by weight in homogeneous material)

(3) MSL, Peak Temp. - The Moisture Sensitivity Level rating according to the JEDEC industry standard classifications, and peak solder temperature.

(4) There may be additional marking, which relates to the logo, the lot trace code information, or the environmental category on the device.

⁽⁵⁾ Multiple Device Markings will be inside parentheses. Only one Device Marking contained in parentheses and separated by a "-" will appear on a device. If a line is indented then it is a continuation of the previous line and the two combined represent the entire Device Marking for that device.

⁽⁶⁾ Lead/Ball Finish - Orderable Devices may have multiple material finish options. Finish options are separated by a vertical ruled line. Lead/Ball Finish values may wrap to two lines if the finish value exceeds the maximum column width.

Important Information and Disclaimer:The information provided on this page represents TI's knowledge and belief as of the date that it is provided. TI bases its knowledge and belief on information provided by third parties, and makes no representation or warranty as to the accuracy of such information. Efforts are underway to better integrate information from third parties. TI has taken and continues to take reasonable steps to provide representative and accurate information but may not have conducted destructive testing or chemical analysis on incoming materials and chemicals. TI and TI suppliers consider certain information to be proprietary, and thus CAS numbers and other limited information may not be available for release.

In no event shall TI's liability arising out of such information exceed the total purchase price of the TI part(s) at issue in this document sold by TI to Customer on an annual basis.

TAPE AND REEL INFORMATION



QUADRANT ASSIGNMENTS FOR PIN 1 ORIENTATION IN TAPE



*All dimensions are nominal

Device	Package Type	Package Drawing	Pins	SPQ	Reel Diameter (mm)	Reel Width W1 (mm)	A0 (mm)	B0 (mm)	K0 (mm)	P1 (mm)	W (mm)	Pin1 Quadrant
SN65LVDS047DR	SOIC	D	16	2500	330.0	16.4	6.5	10.3	2.1	8.0	16.0	Q1
SN65LVDS047PWR	TSSOP	PW	16	2000	330.0	12.4	6.9	5.6	1.6	8.0	12.0	Q1

TAPE AND REEL BOX DIMENSIONS

*All dimensions are nominal

Device	Package Type	Package Drawing	Pins	SPQ	Length (mm)	Width (mm)	Height (mm)
SN65LVDS047DR	SOIC	D	16	2500	350.0	350.0	43.0
SN65LVDS047PWR	TSSOP	PW	16	2000	350.0	350.0	43.0

D (R-PDSO-G16)

PLASTIC SMALL OUTLINE



- NOTES:
- All linear dimensions are in millimeters.
 - This drawing is subject to change without notice.
 - Publication IPC-7351 is recommended for alternate designs.
 - Laser cutting apertures with trapezoidal walls and also rounding corners will offer better paste release. Customers should contact their board assembly site for stencil design recommendations. Refer to IPC-7525 for other stencil recommendations.
 - Customers should contact their board fabrication site for solder mask tolerances between and around signal pads.



4220204/A 02/2017

NOTES:

- All linear dimensions are in millimeters. Any dimensions in parenthesis are for reference only. Dimensioning and tolerancing per ASME Y14.5M.
- This drawing is subject to change without notice.
- This dimension does not include mold flash, protrusions, or gate burrs. Mold flash, protrusions, or gate burrs shall not exceed 0.15 mm per side.
- This dimension does not include interlead flash. Interlead flash shall not exceed 0.25 mm per side.
- Reference JEDEC registration MO-153.

EXAMPLE BOARD LAYOUT

PW0016A

TSSOP - 1.2 mm max height

SMALL OUTLINE PACKAGE



LAND PATTERN EXAMPLE
EXPOSED METAL SHOWN
SCALE: 10X



SOLDER MASK DETAILS

4220204/A 02/2017

NOTES: (continued)

- 6. Publication IPC-7351 may have alternate designs.
- 7. Solder mask tolerances between and around signal pads can vary based on board fabrication site.

EXAMPLE STENCIL DESIGN

PW0016A

TSSOP - 1.2 mm max height

SMALL OUTLINE PACKAGE

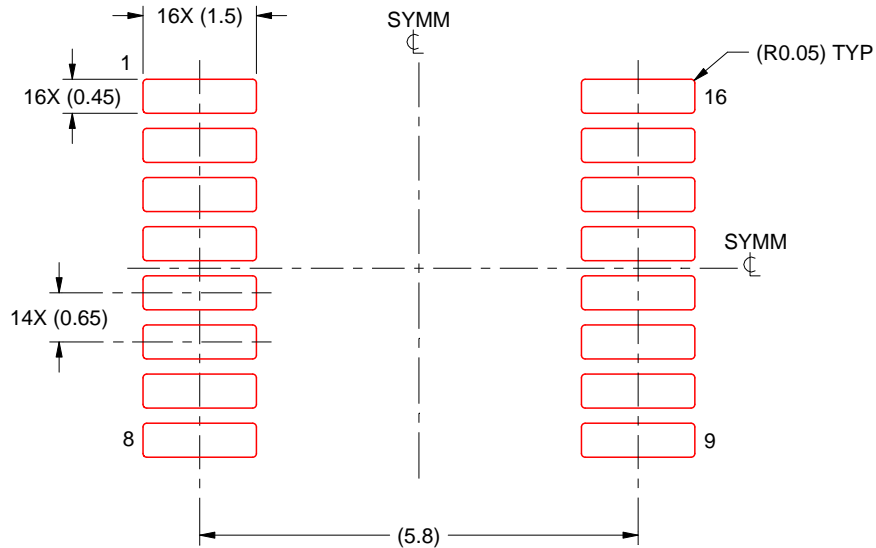

SOLDER PASTE EXAMPLE
BASED ON 0.125 mm THICK STENCIL
SCALE: 10X

4220204/A 02/2017

NOTES: (continued)

8. Laser cutting apertures with trapezoidal walls and rounded corners may offer better paste release. IPC-7525 may have alternate design recommendations.
9. Board assembly site may have different recommendations for stencil design.

IMPORTANT NOTICE AND DISCLAIMER

TI PROVIDES TECHNICAL AND RELIABILITY DATA (INCLUDING DATASHEETS), DESIGN RESOURCES (INCLUDING REFERENCE DESIGNS), APPLICATION OR OTHER DESIGN ADVICE, WEB TOOLS, SAFETY INFORMATION, AND OTHER RESOURCES "AS IS" AND WITH ALL FAULTS, AND DISCLAIMS ALL WARRANTIES, EXPRESS AND IMPLIED, INCLUDING WITHOUT LIMITATION ANY IMPLIED WARRANTIES OF MERCHANTABILITY, FITNESS FOR A PARTICULAR PURPOSE OR NON-INFRINGEMENT OF THIRD PARTY INTELLECTUAL PROPERTY RIGHTS.

These resources are intended for skilled developers designing with TI products. You are solely responsible for (1) selecting the appropriate TI products for your application, (2) designing, validating and testing your application, and (3) ensuring your application meets applicable standards, and any other safety, security, or other requirements. These resources are subject to change without notice. TI grants you permission to use these resources only for development of an application that uses the TI products described in the resource. Other reproduction and display of these resources is prohibited. No license is granted to any other TI intellectual property right or to any third party intellectual property right. TI disclaims responsibility for, and you will fully indemnify TI and its representatives against, any claims, damages, costs, losses, and liabilities arising out of your use of these resources.

TI's products are provided subject to TI's Terms of Sale (www.ti.com/legal/termsofsale.html) or other applicable terms available either on ti.com or provided in conjunction with such TI products. TI's provision of these resources does not expand or otherwise alter TI's applicable warranties or warranty disclaimers for TI products.

Mailing Address: Texas Instruments, Post Office Box 655303, Dallas, Texas 75265
Copyright © 2019, Texas Instruments Incorporated

Looking for pricing, stock, or lifecycle information?

Click below to explore more details on WIN SOURCE:

 [View SN65LVDS047PWRG4 on WIN SOURCE](#)

 [Texas Instruments](#) Information

Optimize Your Supply Chain with WIN SOURCE Solutions

-  Global Sourcing Solution
-  Obsolete Management
-  Cost Control Management
-  Shortage Management
-  Alternative Solution
-  Excess Inventory Management