



**THE DATASHEET OF  
AD1980JST-REEL**



### FEATURES

- AC '97 2.3 COMPATIBLE FEATURES
- 6 DAC Channels for 5.1 Surround
- S/PDIF Output
- Integrated Stereo Headphone Amplifier
- Variable Rate Audio
- Double Rate Audio ( $f_s = 96$  kHz)
- Greater than 90 dB Dynamic Range
- 20-Bit PCM DACs
- Line-Level Mono "Phone" Input
- High Quality CD Input
- Selectable MIC Input with Preamp
- AUX and Line\_In Stereo Inputs
- External Amplifier Power-Down Control
- Power Management Modes
- 48-Lead LQFP Package

### ENHANCED FEATURES

- Integrated Parametric Equalizer
- Stereo MIC Preamp Support
- Integrated PLL for System Clocking
- Variable Sample Rate 7 kHz to 96 kHz
- Jack Sense (Auto Topology Switching)
- Software Controlled VREF\_OUT for MIC Bias
- Software Enabled Outputs for Jack Sharing
- Auto Down-Mix and Channel Spreading Modes

### FUNCTIONAL BLOCK DIAGRAM

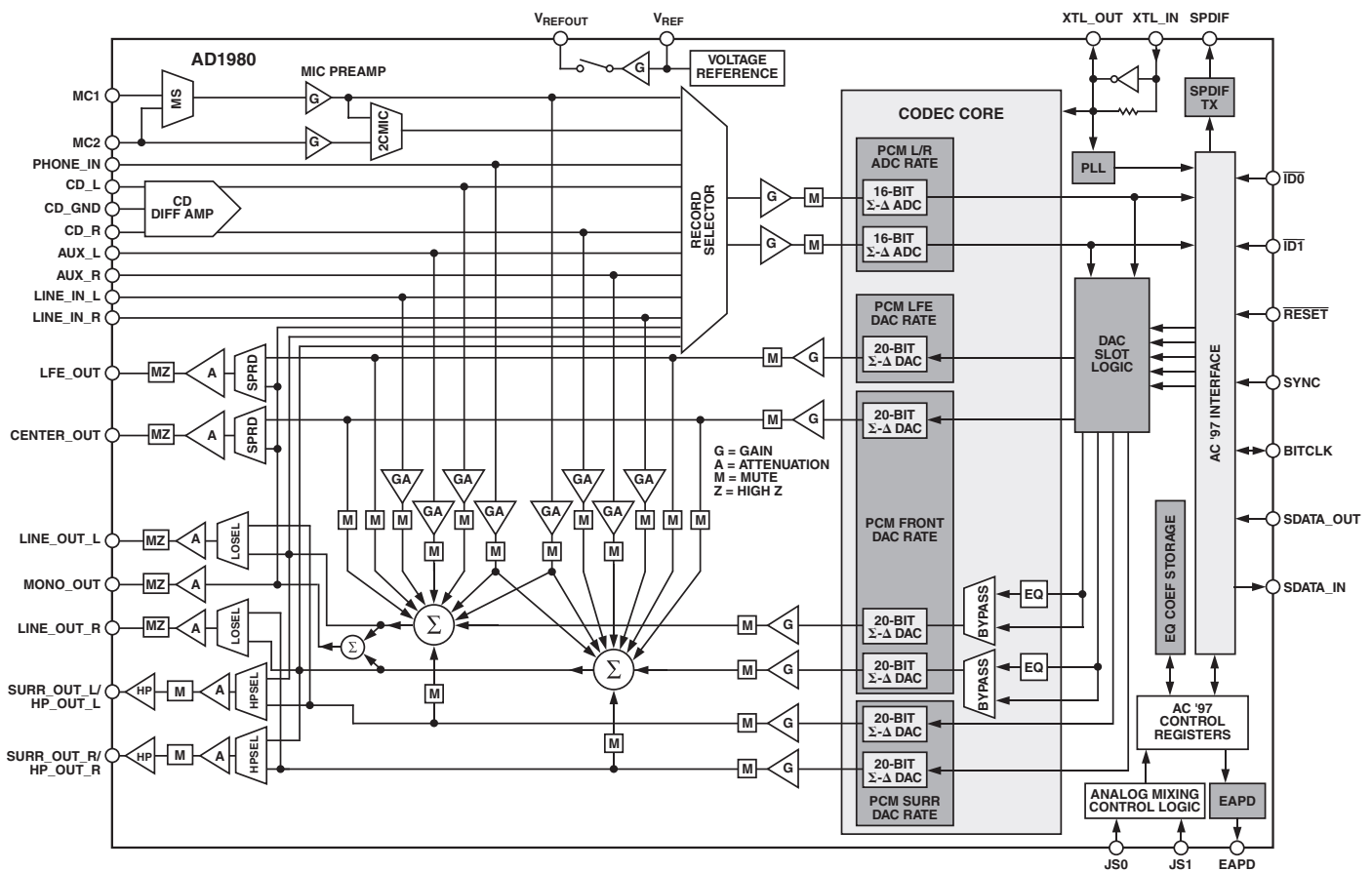

REV. 0

Information furnished by Analog Devices is believed to be accurate and reliable. However, no responsibility is assumed by Analog Devices for its use, nor for any infringements of patents or other rights of third parties that may result from its use. No license is granted by implication or otherwise under any patent or patent rights of Analog Devices. Trademarks and registered trademarks are the property of their respective companies.

# AD1980—SPECIFICATIONS

## STANDARD TEST CONDITIONS, UNLESS OTHERWISE NOTED

Temperature	25°C
Digital Supply (DV <sub>DD</sub> )	3.3 V
Analog Supply (AV <sub>DD</sub> )	5.0 V
Sample Rate (f <sub>s</sub> )	48 kHz
Input Signal	1008 Hz
Analog Output Pass Band	20 Hz to 20 kHz

## DAC Test Conditions

Calibrated
-3 dB Attenuation Relative to Full Scale
0 dB Input
10 kΩ Output Load LINE_OUT, MONO_OUT, CENTER_OUT, and LFE_OUT
32 Ω Output Load (HP_OUT)

## ADC Test Conditions

Calibrated
0 dB Gain
Input -3.0 dB Relative to Full Scale

Parameter	Min	Typ	Max	Unit
<b>ANALOG INPUT</b>				
Input Voltage (rms Values Assume Sine Wave Input) LINE_IN, CD, AUX, PHONE_IN		1 2.83		V rms V p-p
MIC_IN with 30 dB Preamp		0.032		V rms
MIC_IN with 20 dB Preamp		0.089		V p-p
MIC_IN with 10 dB Preamp		0.1 0.283		V rms V p-p
MIC_IN with 0 dB Gain		0.316 0.894		V rms V p-p
Input Impedance*		1 2.83		V rms V p-p
Input Capacitance*		20	7.5	kΩ pF
<b>MASTER VOLUME</b>				
Step Size (Line Out, Mono Out, Surround Out, Center, LFE)		1.5		dB
Output Attenuation Range Span*		46.5		dB
Mute Attenuation of 0 dB Fundamental*			80	dB
<b>PROGRAMMABLE GAIN AMPLIFIER—ADC</b>				
Step Size (0 dB to 22.5 dB)		1.5		dB
PGA Gain Range Span		22.5		dB
<b>ANALOG MIXER—INPUT GAIN/AMPLIFIERS/ATTENUATORS</b>				
Signal-to-Noise Ratio (SNR) CD to LINE_OUT		90		dB
LINE, AUX, PHONE, to LINE_OUT*		90		dB
MIC1 or MIC2 (Note: MIC Gain of 0 dB) to LINE_OUT*		90		dB
Step Size All Mixer Inputs		1.5		dB
Input Gain/Attenuation Range: All Mixer Inputs		46.5		dB
<b>DIGITAL DECIMATION AND INTERPOLATION FILTERS*</b>				
Pass Band	0		0.4 × f <sub>s</sub>	Hz
Pass-Band Ripple			±0.09	dB
Transition Band	0.4 × f <sub>s</sub>		0.6 × f <sub>s</sub>	Hz
Stop Band	0.6 × f <sub>s</sub>		∞	Hz
Stop-Band Rejection	-74			dB
Group Delay		16/f <sub>s</sub>		sec
Group Delay Variation over Pass Band		0		μs

Parameter	Min	Typ	Max	Unit
<b>ANALOG-TO-DIGITAL CONVERTERS</b>				
Resolution		16		Bits
Total Harmonic Distortion (THD) $AV_{DD} = 5.0$ V		-78		dB
Dynamic Range (-60 dB Input THD + N Referenced to FS, A-Weighted) $AV_{DD} = 5.0$ V		82		dB
Signal-to-Intermodulation Distortion* (CCIF Method)		84		dB
ADC Crosstalk*				
Line Inputs (Input L, Ground R, Read R; Input R, Ground L, Read L)		-95	-90	dB
LINE_IN to Other		-90	-85	dB
Gain Error (Full-Scale Span Relative to Nominal Input Voltage)			$\pm 10$	%
Interchannel Gain Mismatch (Difference of Gain Errors)			$\pm 0.5$	dB
ADC Offset Error* (0 dB Gain, HPF On)			$\pm 10$	mV
<b>DIGITAL-TO-ANALOG CONVERTERS</b>				
Resolution		20		Bits
Total Harmonic Distortion (THD), LINE_OUT, $AV_{DD} = 5.0$ V		-90		dB
Total Harmonic Distortion (THD), HP_OUT, $AV_{DD} = 5.0$ V		-73		dB
Total Harmonic Distortion (THD), CENTER/LFE, $AV_{DD} = 5.0$ V		-82.5		dB
Dynamic Range (-60 dB Input THD + N Referenced to FS A-Weighted) $AV_{DD} = 5.0$ V		90		dB
Signal-to-Intermodulation Distortion* (CCIF Method)		88		dB
Gain Error (Full-Scale Span Relative to Nominal Input Voltage)			$\pm 10$	%
Interchannel Gain Mismatch (Difference of Gain Errors)			$\pm 0.7$	dB
DAC Crosstalk (Input L, Zero R, Read LINE_OUT_R; Input R, Zero L, Read LINE_OUT_L, 10 k $\Omega$ Load)*			-80	dB
Total Audible Out-of-Band Energy* (Measured from $0.6 \times f_s$ to 20 kHz)		-40		dB
<b>ANALOG OUTPUT</b>				
Full-Scale Output Voltage; LINE_OUT/MONO_OUT, CENTER_OUT, LFE_OUT		1 2.83		V rms V p-p
Output Impedance*			800	$\Omega$
External Load Impedance* (LINE_OUT, CENTER_OUT/LFE_OUT, MONO_OUT)	10			k $\Omega$
Output Capacitance*		15		pF
External Load Capacitance*			100	pF
Full-Scale Output Voltage; HP_OUT (0 dB Gain)		1		V rms
External Load Impedance*; HP_OUT	32			$\Omega$
$V_{REF}$	2.05	2.25	2.45	V
$V_{REF\_OUT}$ ( $V_{REFH} = 0$ )		2.25		V
$V_{REF\_OUT}$ ( $V_{REFH} = 1$ )		3.65		V
$V_{REF\_OUT}$ Current Drive			5	mA
Mute Click (Muted Output Minus Unmuted Midscale DAC Output)		$\pm 5$		mV
<b>STATIC DIGITAL SPECIFICATIONS</b>				
High Level Input Voltage ( $V_{IH}$ ): Digital Inputs	$0.65 \times DV_{DD}$			V
Low Level Input Voltage ( $V_{IL}$ )			$0.35 \times DV_{DD}$	V
High Level Output Voltage ( $V_{OH}$ ), $I_{OH} = 2$ mA	$0.9 \times DV_{DD}$			V
Low Level Output Voltage ( $V_{OL}$ ), $I_{OL} = 2$ mA			$0.1 \times DV_{DD}$	V
Input Leakage Current	-10		+10	$\mu$ A
Output Leakage Current	-10		+10	$\mu$ A
<b>POWER SUPPLY</b>				
Power Supply Range; Analog ( $AV_{DD}$ )	4.75		5.25	V
Power Supply Range; Digital ( $DV_{DD}$ )	3.15		3.45	V
Power Dissipation 5 V/3.3 V		563		mW
Analog Supply Current 5 V ( $AV_{DD}$ )		70		mA
Digital Supply Current 3.3 V ( $DV_{DD}$ )		53		mA
Power Supply Rejection (100 mV p-p Signal @ 1 kHz)* (At Both Analog and Digital Supply Pins, Both ADCs and DACs)		40		dB

\*Guaranteed but not tested.

Specifications subject to change without notice.

# AD1980

Parameter	PR[K:I] <sup>1</sup>	PR[6:0] <sup>1</sup>	DV <sub>DD</sub> Typ	AV <sub>DD</sub> Typ	Unit
<b>POWER-DOWN STATES<sup>2</sup></b>					
Fully Active	000	000 0000	53	70	mA
ADC	000	000 0001	44	66	mA
FRONT DAC	000	000 0010	46	61	mA
SURROUND DAC	010	000 0000	46	61	mA
CENTER/LFE DAC	101	000 0000	46	61	mA
ADC + ALL DACs	111	000 0011	12	33	mA
Mixer	000	000 0100	52	44	mA
ADC + Mixer	000	000 0101	45	39	mA
ALL DACs + Mixer	111	000 0110	31	14	mA
ADC + ALL DACs + Mixer	111	000 0111	12	8	mA
Standby	111	011 1111	0	0	mA
Headphone Standby	000	100 0000	52	65	mA

## NOTES

<sup>1</sup>PR bits are controlled in Reg. 2Ah and 26h

<sup>2</sup>Values presented with V<sub>REFOUT</sub> loaded.

Specifications subject to change without notice.

Parameter	Min	Typ	Max	Unit
<b>CLOCK SPECIFICATIONS*</b>				
Input Clock Frequency (XTAL Mode or Clock Oscillator)		24.576		MHz
Input Clock Frequency (Reference Clock Mode)		14.31818		MHz
Input Clock Frequency (USB Clock Mode)		48.000		MHz
Recommended Clock Duty Cycle	40	50	60	%

\*Guaranteed but not tested.

Specifications subject to change without notice.

## TIMING PARAMETERS (Guaranteed over Operating Temperature Range)

Parameter	Symbol	Min	Typ	Max	Unit
RESET Active Low Pulsewidth	t <sub>RST_LOW</sub>		1.0		μs
RESET Inactive to BIT_CLK Startup Delay	t <sub>RST2CLK</sub>	162.8		400,000	ns
SYNC Active High Pulsewidth	t <sub>SYNC_HIGH</sub>		1.3		μs
SYNC Low Pulsewidth	t <sub>SYNC_LOW</sub>		19.5		μs
SYNC Inactive to BIT_CLK Startup Delay	t <sub>SYNC2CLK</sub>	162.8			ns
BIT_CLK Frequency			12.288		MHz
BIT_CLK Frequency Accuracy				±1.0	ppm
BIT_CLK Period	t <sub>CLK_PERIOD</sub>		81.4		ns
BIT_CLK Output Jitter <sup>1, 2</sup>			750		ps
BIT_CLK High Pulsewidth	t <sub>CLK_HIGH</sub>	40		41.7	ns
BIT_CLK Low Pulsewidth	t <sub>CLK_LOW</sub>	39.7		41.4	ns
SYNC Frequency			48.0		kHz
SYNC Period	t <sub>SYNC_PERIOD</sub>		20.8		μs
Setup to Falling Edge of BIT_CLK	t <sub>SETUP</sub>	4			ns
Hold from Falling Edge of BIT_CLK	t <sub>HOLD</sub>	3			ns
BIT_CLK Rise Time	t <sub>RISECLK</sub>	2	4	6	ns
BIT_CLK Fall Time	t <sub>FALLCLK</sub>	2	4	6	ns
SYNC Rise Time	t <sub>RISESYNC</sub>	2	4	6	ns
SYNC Fall Time	t <sub>FALLSYNC</sub>	2	4	6	ns
SDATA_IN Rise Time	t <sub>RISEDIN</sub>	2	4	6	ns
SDATA_IN Fall Time	t <sub>FALLDIN</sub>	2	4	6	ns
SDATA_OUT Rise Time	t <sub>RISEDOUT</sub>	2	4	6	ns
SDATA_OUT Fall Time	t <sub>FALLDOUT</sub>	2	4	6	ns
End of Slot 2 to BIT_CLK, SDATA_IN Low	t <sub>S2_PDOW</sub>	0		1.0	μs
Setup to RESET Inactive (SYNC, SDATA_OUT)	t <sub>SETUP2RST</sub>	15			ns
Rising Edge of RESET to Hi-Z Delay	t <sub>OFF</sub>			25	ns
Propagation Delay				15	ns
RESET Rise Time				50	ns
Output Valid Delay from BIT_CLK Rising				15	ns

## NOTES

<sup>1</sup>Guaranteed but not tested.

<sup>2</sup>Output jitter directly dependent on crystal input jitter.

Specifications subject to change without notice.

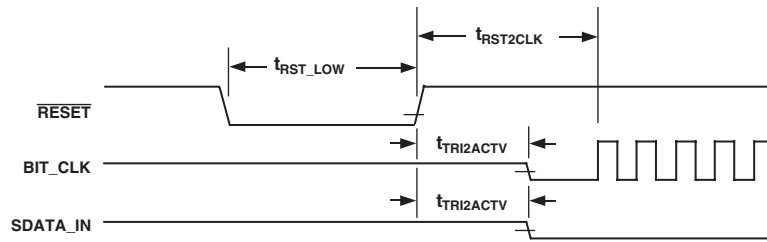

Figure 1. Cold Reset Timing (Codec is Supplying the Bit\_CLK Signal)

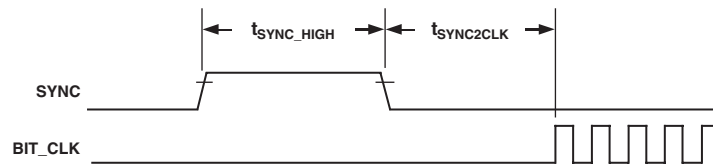

Figure 2. Warm Reset Timing

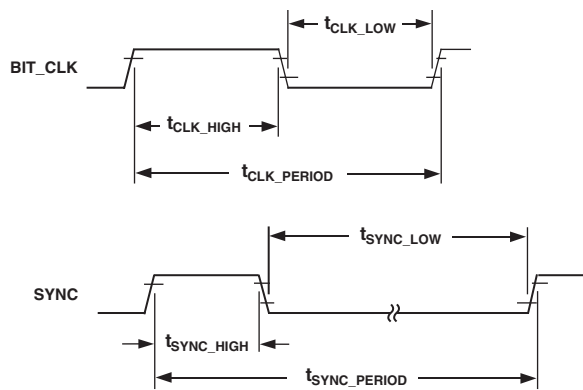

Figure 3. Clock Timing

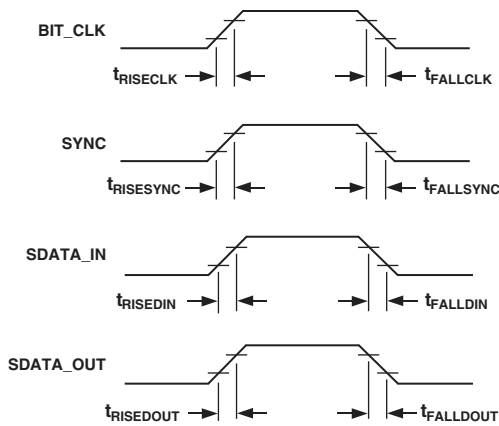

Figure 4. Signal Rise and Fall Times

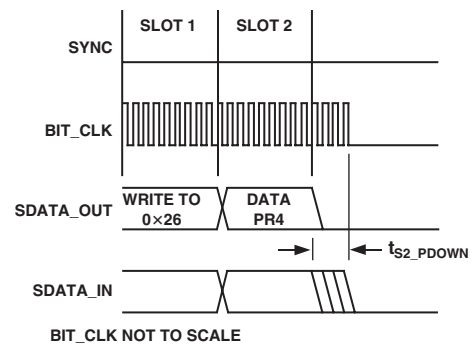

Figure 5. AC-Link Low Power Mode Timing

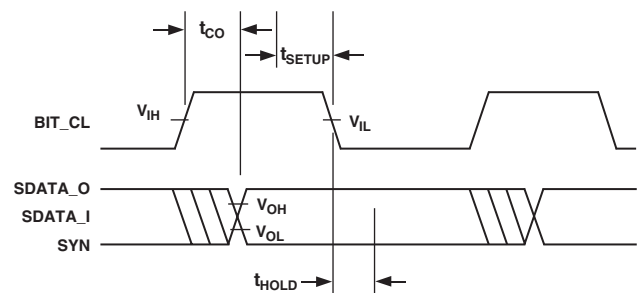

Figure 6. AC-Link Low Power Mode Timing

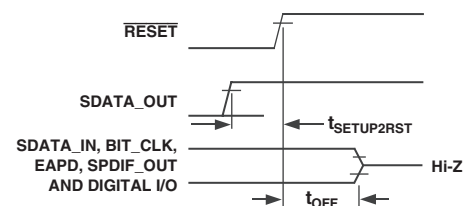

Figure 7. ATE Test Mode

# AD1980

## ABSOLUTE MAXIMUM RATINGS\*

Parameter	Min	Max	Unit
Power Supplies			
Digital (DV <sub>DD</sub> )	-0.3	+3.6	V
Analog (AV <sub>DD</sub> )	-0.3	+6.0	V
Input Current (Except Supply Pins)		±10.0	mA
Analog Input Voltage (Signal Pins)	-0.3	AV <sub>DD</sub> + 0.3	V
Digital Input Voltage (Signal Pins)	-0.3	DV <sub>DD</sub> + 0.3	V
Ambient Temperature (Operating)	0	70	°C
Storage Temperature	-65	+150	°C

\*Stresses greater than those listed under Absolute Maximum Ratings may cause permanent damage to the device. This is a stress rating only and functional operation of the device at these or any other conditions above those indicated in the operational section of this specification is not implied. Exposure to absolute maximum rating conditions for extended periods may affect device reliability.

## ENVIRONMENTAL CONDITIONS\*

Ambient Temperature Rating  
 TCASE = Case Temperature in °C  
 PD = Power Dissipation in W  
 $\theta_{JA}$  = Thermal Resistance (Junction-to-Ambient)  
 $\theta_{JC}$  = Thermal Resistance (Junction-to-Case)

Package	$\theta_{JA}$	$\theta_{JC}$
LQFP	50.1°C/W	17.8°C/W

\*All measurements per EIA/JESD51 with 2S2P test board per EIA/JESD51-7.

## ORDERING GUIDE

Model	Temperature Range	Package Description	Package Option*
AD1980JST	0°C to 70°C	48-Lead LQFP	ST-48

\*ST = Low Profile Quad Flatpack

## CAUTION

ESD (electrostatic discharge) sensitive device. Electrostatic charges as high as 4000 V readily accumulate on the human body and test equipment and can discharge without detection. Although the AD1980 features proprietary ESD protection circuitry, permanent damage may occur on devices subjected to high energy electrostatic discharges. Therefore, proper ESD precautions are recommended to avoid performance degradation or loss of functionality.



## PIN CONFIGURATION 48-Lead LQFP

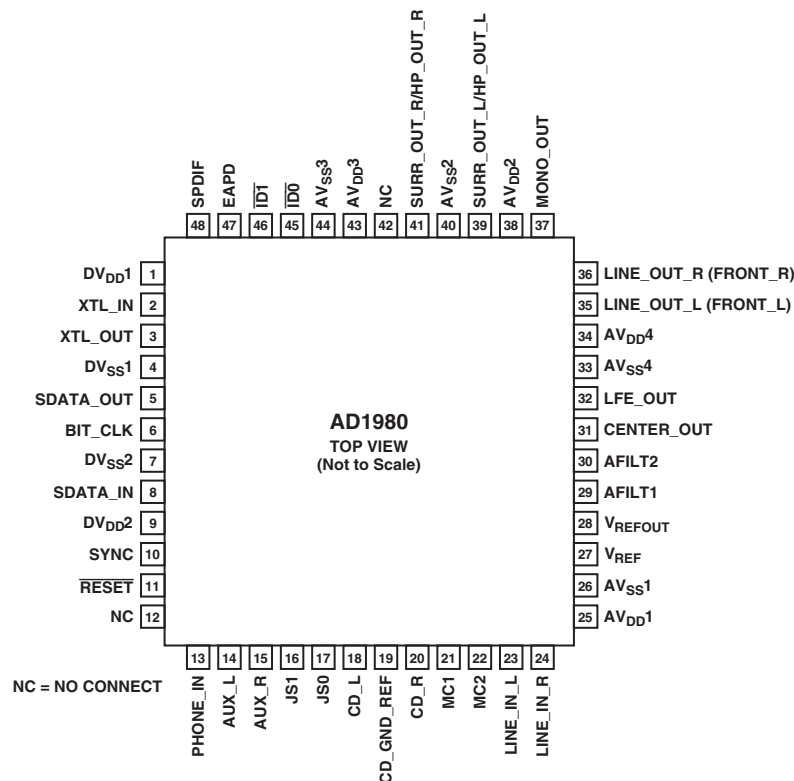

NC = NO CONNECT

## PIN FUNCTION DESCRIPTIONS

Pin Number	Mnemonic	I/O	Function
<b>DIGITAL INPUT/OUTPUT</b>			
2	XTL_IN	I	Crystal Input (24.576 MHz) or External Clock In (24.576 MHz, 14.31818 MHz or 48000 MHz)
3	XTL_OUT	O	Crystal Output
5	SDATA_OUT	I	AC-Link Serial Data Output. AD1980 Input Stream.
6	BIT_CLK	O/I	AC-Link Bit Clock. 12.288 MHz serial data clock. (Input pin, for Secondary mode only.)
8	SDATA_IN	O	AC-Link Serial Data Input. AD1980 Output Stream.
10	SYNC	I	AC-Link Frame Sync
11	RESET	I	AC-Link Reset. AD1980 Master H/W Reset.
48	SPDIF	O	SPDIF Output
<b>CHIP SELECTS/CLOCK STRAPPING</b>			
45	$\overline{\text{ID0}}$	I	Chip Select Input 0 (Active Low). This pin can also be used as the chain input from a secondary Codec.
46	$\overline{\text{ID1}}$	I	Chip Select Input 1 (Active Low)
<b>JACK SENSE AND EAPD</b>			
47	EAPD	O	EAPD Output
17	JS0	I	Jack Sense 0 Input
16	JS1	I	Jack Sense 1 Input
<b>ANALOG INPUT/OUTPUT</b>			
13	PHONE_IN	I	Monaural Line-Level Input
14	AUX_L	I	Auxiliary Input, Left Channel
15	AUX_R	I	Auxiliary Input, Right Channel
18	CD_L	I	CD Audio Left Channel
19	CD_GND_REF	I	CD Audio Analog Ground Reference for Differential CD Input
20	CD_R	I	CD Audio Right Channel
21	MIC1	I	Microphone #1 Input (Left Channel when 2-Channel Mode Selected)
22	MIC2	I	Microphone #2 Input (Right Channel when 2-Channel Mode Selected)
23	LINE_IN_L	I	Line-In Left Channel
24	LINE_IN_R	I	Line-In Right Channel
31	CENTER_OUT	O	Center Channel Output
32	LFE_OUT	O	Low Frequency Enhanced Output
35	LINE_OUT_L	O	Line-Out (Front) Left Channel
36	LINE_OUT_R	O	Line-Out (Front) Right Channel
37	MONO_OUT	O	Monaural Output to Telephone Subsystem Speakerphone
39	SURR_OUT_L/HP_OUT_L	O	Surround or Front Headphone Left Channel Output
41	SURR_OUT_R/HP_OUT_R	O	Surround or Front Headphone Right Channel Output
<b>FILTER/REFERENCE</b>			
27	V <sub>REF</sub>	O	Voltage Reference Filter
28	V <sub>REFOUT</sub>	O	Voltage Reference Output 5 mA Drive (intended for MIC bias)
29	AFILT1	O	Antialiasing Filter Capacitor—ADC Right Channel
30	AFILT2	O	Antialiasing Filter Capacitor—ADC Left Channel

# AD1980

Pin Number	Mnemonic	I/O	Function
POWER AND GROUND SIGNALS			
1	DV <sub>DD1</sub>	I	Digital V <sub>DD</sub> 3.3 V
4	DV <sub>SS1</sub>	I	Digital GND
7	DV <sub>SS2</sub>	I	Digital GND
9	DV <sub>DD2</sub>	I	Digital V <sub>DD</sub> 3.3 V
25	AV <sub>DD1</sub>	I	Analog V <sub>DD</sub> 5.0 V
26	AV <sub>SS1</sub>	I	Analog GND
33	AV <sub>SS4</sub>	I	Analog GND
34	AV <sub>DD4</sub>	I	Analog V <sub>DD</sub> 5.0 V
38	AV <sub>DD2</sub>	I	Analog V <sub>DD</sub> 5.0 V
40	AV <sub>SS2</sub>	I	Analog GND
43	AV <sub>DD3</sub>	I	Analog V <sub>DD</sub> 5.0 V
44	AV <sub>SS3</sub>	I	Analog GND
NO CONNECTS			
12	NC		No Connect
42	NC		No Connect

## Indexed Control Registers

Reg	Name	D15	D14	D13	D12	D11	D10	D9	D8	D7	D6	D5	D4	D3	D2	D1	D0	Default
00h	Reset	X	SE4	SE3	SE2	SE1	SE0	ID9	ID8	ID7	ID6	ID5	ID4	ID3	ID2	ID1	ID0	0090h
02h	Master Volume	MM	X	LMV5	LMV4	LMV3	LMV2	LMV1	LMV0	MMRM*	X	RMV5	RMV4	RMV3	RMV2	RMV1	RMV0	8000h
04h	Headphone Volume	HPM	X	LHV5	LHV4	LHV3	LHV2	LHV1	LHV0	HPRM*	X	RHV5	RHV4	RHV3	RHV2	RHV1	RHV0	8000h
06h	Mono Volume	MVM	X	X	X	X	X	X	X	X	X	MV5	MV4	MV3	MV2	MV1	MV0	8000h
0Ch	Phone Volume	PHM	X	X	X	X	X	X	X	X	X	X	PHV4	PHV3	PHV2	PHV1	PHV0	8008h
0Eh	Mic Volume	MCM	X	X	X	X	X	X	X	X	M20	X	MCV4	MCV3	MCV2	MCV1	MCV0	8008h
10h	Line In Volume	LVM	X	X	LLV4	LLV3	LLV2	LLV1	LLV0	LVRM*	X	X	RLV4	RLV3	RLV2	RLV1	RLV0	8808h
12h	CD Volume	CVM	X	X	LCV4	LCV3	LCV2	LCV1	LCV0	CDRM*	X	X	RCV4	RCV3	RCV2	RCV1	RCV0	8808h
16h	AUX Volume	AVM	X	X	LAV4	LAV3	LAV2	LAV1	LAV0	AVRM*	X	X	RAV4	RAV3	RAV2	RAV1	RAV0	8808h
18h	PCM Out Vol	OM	X	X	LOV4	LOV3	LOV2	LOV1	LOV0	OMRM*	X	X	ROV4	ROV3	ROV2	ROV1	ROV0	8808h
1Ah	Record Select	X	X	X	X	X	LS2	LS1	LS0	X	X	X	X	X	RS2	RS1	RS0	0000h
1Ch	Record Gain	IM	X	X	X	LIM3	LIM2	LIM1	LIM0	IMRM	X	X	X	RIM3	RIM2	RIM1	RIM0	8000h
20h	General Purpose	X	X	X	X	DRSS1	DRSS0	X	MS	LPBK	X	X	X	X	X	X	X	0000h
24h	Audio Int. and Paging	I4	X	X	X	I0	X	X	X	X	X	X	X	PG3	PG2	PG1	PG0	xxxx
26h	Power-Down Ctrl/Stat	EAPD	PR6	PR5	PR4	PR3	PR2	PR1	PR0	X	X	X	X	REF	ANL	DAC	ADC	0NA
28h	Ext'd Audio ID	ID1	ID0	X	X	REV1	REV0	AMAP	LDAC	SDAC	CDAC	DSA1	DSA0	X	SPDIF	DRA	VRAS	x3C7h
2Ah	Ext'd Audio Stat/Ctrl	VFORCE	X	PRK	PRJ	PRI	SPCV	X	ELDAC	ESDAC	ECDAC	SPSA1	SPSA0	X	ESPDIF	EDRA	EVRA	0xx0h
2Ch	PCM Front DAC Rate	SRF15	SRF14	SRF13	SRF12	SRF11	SRF10	SRF9	SRF8	SRF7	SRF6	SRF5	SRF4	SRF3	SRF2	SRF1	SRF0	BB80h
2Eh	PCM Surr DAC Rate	SRS15	SRS14	SRS13	SRS12	SRS11	SRS10	SRS9	SRS8	SRS7	SRS6	SRS5	SRS4	SRS3	SRS2	SRS1	SRS0	BB80h
30h	PCM C/LFE DAC Rate	SRCL15	SRCL14	SRCL13	SRCL12	SRCL11	SRCL10	SRCL9	SRCL8	SRCL7	SRCL6	SRCL5	SRCL4	SRCL3	SRCL2	SRCL1	SRCL0	BB80h
32h	PCM ADC Rate	SRA15	SRA14	SRA13	SRA13	SRA11	SRA10	SRA9	SRA8	SRA7	SRA6	SRA5	SRA4	SRA3	SRA2	SRA1	SRA0	BB80h
36h	Center/LFE Volume	LM	X	LFE5	LFE4	LFE3	LFE2	LFE1	LFE0	CM	X	CNT5	CNT4	CNT3	CNT2	CNT1	CNT0	8080h
38h	Surround Volume	MUTE_L	X	LSR5	LSR4	LSR3	LSR2	LSR1	LSR0	MUTE_R	X	RSR5	RSR4	RSR3	RSR2	RSR1	RSR0	8080h
3Ah	SPDIF Control	V	X	SPSR1	SPSR0	L	CC6	CC5	CC4	CC3	CC2	CC1	CC0	PRE	COPY	/AUD	PRO	2000h
60h	EQ CTRL	EQM	X	X	X	X	X	X	X	SYM	CHS	BCA5	BCA4	BCA3	BCA2	BCA1	BCA0	8080h
62h	EQ DATA	CFD15	CFD14	CFD13	CFD12	CFD11	CFD10	CFD9	CFD8	CFD7	CFD6	CFD5	CFD4	CFD3	CFD2	CFD1	CFD0	0000h
72h	JACK SENSE	JS1 SPRD	JS1 DMX	JS0 DMX	JS MT2	JS MT1	JS MT0	JS1 EQB	JS0 EQB	JS1 TMR	JS0 TMR	JS1 MD	JS0 MD	JS1 ST	JS0 ST	JS1 INT	JS0 INT	0000h
74h	Serial Configuration	SLOT 16	REGM2	REGM1	REGM0	REGM3	DRF	X	CHEN	X	LBK1	LBK0	INTS	X	SPAL	SPDZ	SPLNK	1001h
76h	Misc Control Bits	DACZ	AC97NC	MSPLT	LODIS	CLDIS	HPSEL	DMIX1	DMIX0	SPRD	2CMIC	LOSEL	SRU	VREFH	VREFD	MBG1	MBG0	0000h
7Ch	Vendor ID1	F7	F6	F5	F4	F3	F2	F1	F0	S7	S6	S5	S4	S3	S2	S1	S0	4144h
7Eh	Vendor ID2	T7	T6	T5	T4	T3	T2	T1	T0	REV7	REV6	REV5	REV4	REV3	REV2	REV1	REV0	5370h

## NOTES

All registers not shown and bits containing an X are assumed to be reserved.

Odd register addresses are aliased to the next lower even address.

Reserved registers should not be written to.

Zeros should be written to reserved bits.

\*For AC '97 compatibility, Bit D7 is only available by setting the MSPLT bit, Register 76h. The MSPLT bit enables separate mute bits for the left and right channels. If MSPLT is not set, Bit D7 has no effect.

# AD1980

## Reset Register (Index 00h)

Reg No.	Name	D15	D14	D13	D12	D11	D10	D9	D8	D7	D6	D5	D4	D3	D2	D1	D0	Default
00h	Reset	X	SE4	SE3	SE2	SE1	SE0	ID9	ID8	ID7	ID6	ID5	ID4	ID3	ID2	ID1	ID0	0090h

### NOTES

All registers not shown and bits containing an X are assumed to be reserved.

Writing any value to this register performs a register reset, which causes all registers to revert to their default values (except 74h, which forces the serial configuration).

Reading this register returns the ID code of the part and a code for the type of 3D Stereo Enhancement.

ID[9:0] Identify Capability. The ID decodes the capabilities of AD1980 based on the following:

Bit = 1	Function	AD1980
ID0	Dedicated Mic PCM In Channel	0
ID1	Modem Line Codec Support	0
ID2	Bass and Treble Control	0
ID3	Simulated Stereo (Mono to Stereo)	0
ID4	Headphone Out Support	1
ID5	Loudness (Bass Boost) Support	0
ID6	18-Bit DAC Resolution	0
ID7	20-Bit DAC Resolution	1
ID8	18-Bit ADC Resolution	0
ID9	20-Bit ADC Resolution	0

SE[4:0] Stereo Enhancement. The AD1980 does not provide hardware 3D stereo enhancement. (All bits are zeros.)

## Master Volume Register (Index 02h)

Reg No.	Name	D15	D14	D13 <sup>1</sup>	D12	D11	D10	D9	D8	D7	D6	D5 <sup>1</sup>	D4	D3	D2	D1	D0	Default
02h	Master Volume	MM	X	LMV5	LMV4	LMV3	LMV2	LMV1	LMV0	MMRM <sup>2</sup>	X	RMV5	RMV4	RMV3	RMV2	RMV1	RMV0	8000h

### NOTES

<sup>1</sup>Refer to Table I for examples. This register controls the Line\_Out volume controls for both stereo channels and mute bit. Each volume subregister contains five bits, generating 32 volume levels with 31 steps of 1.5 dB each. Because AC '97 defines 6-bit volume registers, to maintain compatibility whenever the D5 or D13 bits are set to "1," their respective lower five volume bits are automatically set to "1" by the codec logic. On readback, all lower five bits will read "1s" whenever these bits are set to "1."

<sup>2</sup>For AC '97 compatibility, Bit D7 is available only by setting the MSPLT bit, Register 76h. The MSPLT bit enables separate mute bits for the left and right channels. If MSPLT is not set, bit D7 has no effect. All registers not shown and bits containing an X are assumed to be reserved.

Note that depending on the state of the AC97NC bit in Register 0x76, this register has the following additional functionality:

For AC97NC = 0, the register controls the Line\_out output Attenuators only.

For AC97NC = 1, the register controls the Line\_out, Center, and LFE output Attenuators.

RMV[5:0]	Right Master Volume Control. The least significant bit represents 1.5 dB. This register controls the output from 0 dB to a maximum attenuation of 46.5 dB.
RM	Right Channel Mute. Once enabled by the MSPLT bit in Register 76h, this bit mutes the right channel separately from the MM bit. Otherwise this bit will always read "0" and will have no effect when set to "1."
LMV[5:0]	Left Master Volume Control. The least significant bit represents 1.5 dB. This register controls the output from 0 dB to a maximum attenuation of 46.5 dB.
MM	Headphones Volume Mute. When this bit is set to "1," both the left and the right channels are muted, unless the MSPLT bit in Register 76h is set to "1."

## Headphones Volume Register (Index 04h)

Reg No.	Name	D15	D14	D13	D12	D11	D10	D9	D8	D7	D6	D5	D4	D3	D2	D1	D0	Default
04h	Headphones Volume	HPM	X	LHV5	LHV4	LHV3	LHV2	LHV1	LHV0	HPRM*	X	RHV5	RHV4	RHV3	RHV2	RHV1	RHV0	8000h

\*For AC '97 compatibility, Bit D7 is available only by setting the MSPLT bit, Register 76h. The MSPLT bit enables separate mute bits for the left and right channels. If MSPLT is not set, Bit D7 has no effect.

**Table I. Volume Settings for Master and Headphone**

Reg. 76h	Control Bits								
	Master Volume (02h) and Headphone Volume (04h)								
	Left Channel Volume D[13:8]				Right Channel Volume D[5:0]				
MSPLT*	D15	WRITE	READBACK	Function	D7*	WRITE	READBACK	Function	
0	0	00 0000	00 0000	0 dB Gain	x	00 0000	00 0000	0 dB Gain	
0	0	00 1111	00 1111	-22.5 dB Gain	x	00 1111	00 1111	-22.5 dB Gain	
0	0	01 1111	01 1111	-46.5 dB Gain	x	01 1111	01 1111	-46.5 dB Gain	
0	0	1x xxxx	01 1111	-46.5 dB Gain	x	1x xxxx	01 1111	-46.5 dB Gain	
0	1	xx xxxx	xx xxxx	-∞ dB Gain, Muted	x	xx xxxx	xx xxxx	-∞ dB Gain, Muted	
1	0	1x xxxx	01 1111	-46.5 dB Gain	1	xx xxxx	xx xxxx	-∞ dB Gain, only Right Muted	
1	1	xx xxxx	xx xxxx	-∞ dB Gain, Left only Muted	0	xx xxxx	xx xxxx	-46.5 dB Gain	
1	1	xx xxxx	xx xxxx	-∞ dB Gain, Left Muted	1	xx xxxx	xx xxxx	-∞ dB Gain, Right Muted	

\*For AC '97 compatibility, Bit D7 is available only by setting the MSPLT bit, Register 76h. The MSPLT bit enables separate mute bits for the left and right channels. If MSPLT is not set, Bit D7 has no effect.

x in the above table is "don't care."

## Mono Volume Register (Index 06h)

Reg No.	Name	D15	D14	D13	D12	D11	D10	D9	D8	D7	D6	D5*	D4	D3	D2	D1	D0	Default
06h	Mono Volume	MVM	X	X	X	X	X	X	X	X	X	MV5	MV4	MV3	MV2	MV1	MV0	8000h

\*Refer to Table II for examples. This register controls the Mono output volume and mute bit. The volume register contains five bits, generating 32 volume levels with 31 steps of 1.5 dB each. Because AC '97 defines 6-bit volume registers, to maintain compatibility, whenever the D5 bit is set to "1," their respective lower five volume bits are automatically set to "1" by the codec logic. On readback, all lower five bits will read "1s" whenever this bit is set to "1." All registers not shown and bits containing an X are assumed to be reserved.

MV[5:0]	Mono Volume Control. The least significant bit represents 1.5 dB. This register controls the output from 0 dB to a maximum attenuation of 46.5 dB.
MVM	Mono Volume Mute. When this bit is set to "1," the channel is muted.

**Table II. Volume Settings for Mono**

D15	Control Bits D[4:0] for Mono (06h)		Function
	WRITE	READBACK	
0	0 0000	0 0000	0 dB Gain
0	0 1111	0 1111	-22.5 dB Gain
0	1 1111	1 1111	-46.5 dB Gain
1	x xxxx	x xxxx	-∞ dB Gain, Muted

x in the above table is a wild card and has no effect on the value.

# AD1980

## Phone\_in Volume Register (Index 0Ch)

Reg No.	Name	D15	D14	D13	D12	D11	D10	D9	D8	D7	D6	D5	D4	D3	D2	D1	D0	Default
0Ch	Phone_in Volume	PHM	X	X	X	X	X	X	X	X	X	X	PHV4	PHV3	PHV2	PHV1	PHV0	8008h

All registers not shown and bits containing an X are assumed to be reserved. Refer to Table III for examples.

PHV[4:0]	Phone Volume. Allows setting the Phone Volume attenuator in 32 volume levels with 31 steps of 1.5 dB each. The LSB represents 1.5 dB, and the gain range is +12 dB to -34.5 dB. The default value is 0 dB, with the mute bit enabled.
PHM	Phone Mute. When this bit is set to “1,” the Phone channel is muted.

## MIC Volume Register (Index 0Eh)

Reg No.	Name	D15	D14	D13	D12	D11	D10	D9	D8	D7	D6	D5	D4	D3	D2	D1	D0	Default
0Eh	MIC Volume	MCM	X	X	X	X	X	X	X	X	M20	X	MCV4	MCV3	MCV2	MCV1	MCV0	8008h

All registers not shown, and bits containing an X are assumed to be reserved. Refer to Table III for examples.

MCV[4:0]	MIC Volume Gain. Allows setting the MIC Volume attenuator in 32 volume levels. The LSB represents 1.5 dB, and the gain range is +12 dB to -34.5 dB. The default value is 0 dB, with mute enabled.
M20	MIC Gain Boost. This bit allows setting additional MIC gain to increase the microphone sensitivity. The nominal gain boost by default is 20 dB, however, Bits D0 and D1 (MBG[1:0]) on the miscellaneous control bits register (76h) allow changing the gain boost to 10 dB or 30 dB, if necessary. 0 = Disabled; Gain = 0 dB 1 = Enabled; Default Gain = 20 dB (see Register 76h, Bits D0, D1)
MCM	MIC Mute. When this bit is set to “1,” the channel is muted.

**Table III. Volume Settings for Phone and MIC**

D15	Control Bits D[4:0] Phone (0Ch) and MIC (0Eh)		Function
	WRITE	READBACK	
0	0 0000	0 0000	12 dB Gain
0	0 1000	0 1000	0 dB Gain
0	1 1111	1 1111	-34.5 dB Gain
1	x xxxx	x xxxx	-∞ dB Gain, Muted

x in the above table is a wild card, and has no effect on the value.

## Line-In Volume Register (Index 10h)

Reg No.	Name	D15	D14	D13	D12	D11	D10	D9	D8	D7	D6	D5	D4	D3	D2	D1	D0	Default
10h	Line-In Volume	LVM	X	X	LLV4	LLV3	LLV2	LLV1	LLV0	LVRM*	X	X	RLV4	RLV3	RLV2	RLV1	RLV0	8808h

\*For AC '97 compatibility, Bit D7 is available only by setting the MSPLT bit, Register 76h. The MSPLT bit enables separate mute bits for the left and right channels. If MSPLT is not set, the Bit D7 has no effect. All registers not shown and bits containing an X are assumed to be reserved. Refer to Table IV for examples.

RLV[4:0]	Right Line-In Volume. Allows setting the Line-In Right channel attenuator in 32 volume levels with 31 steps of 1.5 dB each. The LSB represents 1.5 dB, and the range is +12 dB to -34.d dB. The default value is 0 dB, mute enabled.
RM	Right Channel Mute. Once enabled by the MSPLT bit in Register 76h, this bit mutes the right channel separately from the LIM bit. Otherwise, this bit will always read “0” and will have no effect when set to “1.”
LLV[4:0]	Left Line-In Volume. Allows setting the Line-In left channel attenuator in 32 volume levels with 31 steps of 1.5 dB each. The LSB represents 1.5 dB, and the range is +12 dB to -34.5 dB. The default value is 0 dB, mute enabled.
LVM	Line-In Mute. When this bit is set to “1,” both the left and the right channels are muted, unless the MSPLT bit in Register 76h is set to “1,” in which case this mute bit will only affect the left channel.

## CD Volume Register (Index 12h)

Reg No.	Name	D15	D14	D13	D12	D11	D10	D9	D8	D7	D6	D5	D4	D3	D2	D1	D0	Default
12h	CD Volume	CVM	X	X	LCV4	LCV3	LCV2	LCV1	LCV0	CDRM*	X	X	RCV4	RCV3	RCV2	RCV1	RCV0	8808h

\*For AC '97 compatibility, Bit D7 is available only by setting the MSPLT bit, Register 76h. The MSPLT bit enables separate mute bits for the left and right channels. If MSPLT is not set, the Bit D7 has no effect. All registers not shown and bits containing an X are assumed to be reserved. Refer to Table IV for examples.

RCV[4:0]	Right CD Volume. Allows setting the CD right channel attenuator in 32 volume levels with 31 steps of 1.5 dB each. The LSB represents 1.5 dB, and the range is +12 dB to -34.5 dB. The default value is 0 dB, mute enabled.
RM	Right Channel Mute. Once enabled by the MSPLT bit in Register 76h, this bit mutes the Right channel separately from the CVM bit. Otherwise this bit will always read “0” and will have no effect when set to “1.”
LCV[4:0]	Left CD Volume. Allows setting the CD left channel attenuator in 32 volume levels with 31 steps of 1.5 dB each. The LSB represents 1.5 dB, and the range is +12 dB to -24.5 dB. The default value is 0 dB, mute enabled.
CVM	CD Volume Mute. When this bit is set to “1,” both the left and the right channels are muted, unless the MSPLT bit in Register 76h is set to “1,” in which case this mute bit will affect only the left channel.

## AUX Volume Register (Index 16h)

Reg No.	Name	D15	D14	D13	D12	D11	D10	D9	D8	D7	D6	D5	D4	D3	D2	D1	D0	Default
16h	AUX Volume	AVM	X	X	LAV4	LAV3	LAV2	LAV1	LAV0	AVRM*	X	X	RAV4	RAV3	RAV2	RAV1	RAV0	8808h

\*For AC '97 compatibility, Bit D7 is only available by setting the MSPLT bit, Register 76h. The MSPLT bit enables separate mute bits for the left and right channels. If MSPLT is not set, Bit D7 has no effect. All registers not shown and bits containing an X are assumed to be reserved. Refer to Table IV for examples.

RAV[4:0]	Right AUX Volume. Allows setting the AUX right channel attenuator in 32 volume levels with 31 steps of 1.5 dB each. The LSB represents 1.5 dB, and the range is +12 dB to -34.5 dB. The default value is 0 dB, mute enabled.
RM	Right Channel Mute. Once enabled by the MSPLT bit in Register 76h, this bit mutes the right channel separately from the AVM bit. Otherwise, this bit will always read “0” and will have no affect when set to “1.”
LAV[4:0]	Left PCM Out Volume. Allows setting the PCM left channel attenuator in 32 volume levels. The LSB represents 1.5 dB, and the range is +12 dB to -34.5 dB. The default value is 0 dB, mute enabled.
AVM	PCM Out Volume Mute. When this bit is set to “1,” both the left and the right channels are muted, unless the MSPLT bit in Register 76h is set to “1,” in which case this mute bit will affect only the left channel.

## PCM-Out Volume Register (Index 18h)

Reg No.	Name	D15	D14	D13	D12	D11	D10	D9	D8	D7	D6	D5	D4	D3	D2	D1	D0	Default
18h	PCM Out Volume	OM	X	X	LOV4	LOV3	LOV2	LOV1	LOV0	OMRM*	X	X	ROV4	ROV3	ROV2	ROV1	ROV0	8808h

\*For AC '97 compatibility, Bit D7 is available only by setting the MSPLT bit, Register 76h. The MSPLT bit enables separate mute bits for the left and right channels. If MSPLT is not set, Bit D7 has no effect. All registers not shown and bits containing an X are assumed to be reserved. Refer to Table IV for examples.

Note that depending on the state of the AC97NC bit in Register 76h, this register has the following additional functionality:

For AC87NC = 0, the register also controls the Surround, Center, and LFE DAC Gain/Attenuators.

For AC97NC = 1, the register controls the PCM Out Volume only.

ROV[4:0]	Right PCM Out Volume. Allows setting the PCM right channel attenuator in 32 volume levels. The LSB represents 1.5 dB, and the gain range is +12 dB to -34.5 dB. The default value is 0 dB, mute enabled.
RM	Right Channel Mute. Once enabled by the MSPLT bit in Register 76h, this bit mutes the right channel separately from the AVM bit. Otherwise, this bit will always read "0" and will have no affect when set to "1."
LOV[4:0]	Left PCM Out Volume. Allows setting the PCM left channel attenuator in 32 volume levels. The LSB represents 1.5 dB, and the range is +12 dB to -34.5 dB. The default value is 0 dB, mute enabled.
OM	PCM Out Volume Mute. When this bit is set to "1," both the left and the right channels are muted, unless the MSPLT bit in Register 76h is set to "1," in which case this mute bit will affect only the left channel.

**Table IV. Volume Settings for Line-In, CD Volume, AUX, and PCM-Out**

Reg. 76h	Control Bits							
	Line-In (10h), CD (12h), AUX (16h) and PCM-Out (18h)							
	Left Channel Volume D[12:8]				Right Channel Volume D[4:0]			
MSPLT*	D15	WRITE	READBACK	Function	D7*	WRITE	READBACK	Function
0	0	0 0000	0 0000	12 dB Gain	x	0 0000	0 0000	12 dB Gain
0	0	0 1000	0 1000	0 dB Gain	x	0 1000	0 1000	0 dB Gain
0	0	1 1111	1 1111	-34.5 dB Gain	x	1 1111	1 1111	-34.5 dB Gain
0	1	x xxxx	x xxxx	-∞ dB Gain, Muted	x	x xxxx	x xxxx	-∞ dB Gain, Muted
1	0	1 1111	1 1111	-34.5 dB Gain	1	x xxxx	x xxxx	-∞ dB Gain, Right Only Muted
1	1	x xxxx	x xxxx	-∞ dB Gain, Left Only Muted	0	1 1111	1 1111	-34.5 dB Gain
1	1	x xxxx	x xxxx	-∞ dB Gain, Left Muted	1	x xxxx	x xxxx	-∞ dB Gain, Right Muted

\*For AC '97 compatibility, Bit D7 is only available by setting the MSPLT bit, Register 76h. The MSPLT bit enables separate mute bits for the left and right channels.

If MSPLT is not set, RM Bit has no effect.

x in the above table is "don't care."

## Record Select Control Register (Index 1Ah)

Reg No.	Name	D15	D14	D13	D12	D11	D10	D9	D8	D7	D6	D5	D4	D3	D2	D1	D0	Default
1Ah	Record Select	X	X	X	X	X	LS2	LS1	LS0	X	X	X	X	X	RS2	RS1	RS0	0000h

All registers not shown and bits containing an X are assumed to be reserved.

Refer to Table V for examples. Used to select the record source, independently for the right and left channels. For single MIC recording, see MS bit (Register 20h) for MIC1 and MIC2 input selection.

For dual MIC recording, see 2CMIC bit (Register 76h) to enable simultaneous recording into the left and the right channels.

The default value is 0000h, which corresponds to MIC input for both channels.

RS [2:0]	Right Record Select
LS [2:0]	Left Record Select

Table V. Settings for Record Select Control

LS [10:8]	Left Record Source	RS [2:0]	Right Record Source
000	MIC	000	MIC
001	CD_L	001	CD_R
010	Muted	010	Muted
011	AUX_L	011	AUX_R
100	LINE_IN_L	100	LINE_IN_R
101	Stereo Mix (L)	101	Stereo Mix (R)
110	Mono Mix	110	Mono Mix
111	PHONE_IN	111	PHONE_IN

Record Gain Register (Index 1Ch)

Reg No.	Name	D15	D14	D13	D12	D11	D10	D9	D8	D7	D6	D5	D4	D3	D2	D1	D0	Default
1Ch	Record Gain	IM	X	X	X	LIM3	LIM2	LIM1	LIM0	IMRM*	X	X	X	RIM3	RIM2	RIM1	RIM0	8000h

\*For AC '97 compatibility, Bit D7 is available only by setting the MSPLT bit, Register 76h. The MSPLT bit enables separate mute bits for the left and right channels. If MSPLT is not set, Bit D7 has no effect. All registers not shown, and bits containing an X are assumed to be reserved. Refer to Table VI for examples.

RIM[3:0]	Right Input Mixer Gain Control. Each LSB represents 1.5 dB, 0000 = 0 dB, and the gain range is 0 dB to 22.5 dB.
RM	Right Channel Mute. Once enabled by the MSPLT bit in Register 76h, this bit mutes the right channel separately from the IM bit. Otherwise, this bit will always read "0" and will have no effect when set to "1."
LIM[3:0]	Left Input Mixer Gain Control. Each LSB represents 1.5 dB, 0000 = 0 dB, and the gain range is 0 dB to 22.5 dB.
IM	Input Mute. When this bit is set to "1," both the left and the right channels are muted, unless the MSPLT bit in Register 76h is set to "1," in which case this mute bit will affect only the left channel.

Table VI. Settings for Record Gain Register

Reg. 76h	Control Bits Record Gain (1Ch)							
	Left Channel Input Mixer D[11:8]				Right Channel Input Mixer D[3:0]			
MSPLT*	D15	WRITE	READBACK	Function	D7*	WRITE	READBACK	Function
0	0	1111	1111	22.5 dB Gain	x	1111	1111	22.5 dB Gain
0	0	0000	0000	0 dB Gain	x	0000	0000	0 dB Gain
0	1	xxxx	xxxx	-∞ dB Gain, Muted	x	xxxx	xxxx	-∞ dB Gain, Muted
1	0	1111	1111	22.5 dB Gain	1	xxxx	xxxx	-∞ dB Gain, Right Only Muted
1	1	xxxx	xxxx	-∞ dB Gain, Left Only Muted	0	1111	1111	22.5 dB Gain
1	1	xxxx	xxxx	-∞ dB Gain, Left Muted	1	xxxx	xxxx	-∞ dB Gain, Right Muted

\*For AC '97 compatibility, Bit D7 (RM) is available only by setting the MSPLT bit, Register 76h. The MSPLT bit enables separate mute bits for the left and right channels. If MSPLT is not set, Bit D7 has no effect.  
x is "don't care."

# AD1980

## General-Purpose Register (Index 20h)

Reg No.	Name	D15	D14	D13	D12	D11	D10	D9	D8	D7	D6	D5	D4	D3	D2	D1	D0	Default
20h	General-Purpose	X	X	X	X	DRSS1	DRSS0	X	MS	LPBK	X	X	X	X	X	X	X	0000h

This register should be read before writing to generate a mask for only the bit(s) that need to be changed. All registers not shown and bits containing an X are assumed to be reserved.

LPBK	Loopback Control. This bit enables the digital internal loopback from the ADC to the Front DAC. This feature is normally used for test and troubleshooting. 0 = No Loopback (Default) 1 = Loopback PCM digital data from ADC output to DAC See LBKS bit in Register 0x74 for changing the loopback path to use the Surround or Center/LFE DACs.
MS	MIC Select. Selects Mono MIC input. 0 = Select MIC1 1 = Select MIC2 See 2CMIC bit in Register 76h to enable stereo microphone recording.
DRSS [1:0]	Double Rate Slot Select. The DRSS bits specify the slots for the n + 1 sample outputs. PCM L (n + 1) and PCM R (n + 1) data are by default provided in output slots 10 and 11. 00: PCM L, R n + 1 Data is on Slots 10, 11 (reset default) 01: PCM L, R n + 1 Data is on Slots 7, 8 10: Reserved 11: Reserved

## Audio Interrupt and Paging Mechanism Register (Index 24h)

Reg No.	Name	D15	D14	D13	D12	D11	D10	D9	D8	D7	D6	D5	D4	D3	D2	D1	D0	Default
24h	Audio Interrupt and Paging	I4	X	X	X	I0	X	X	X	X	X	X	X	PG3	PG2	PG1	PG0	xxxxh

This register controls the Audio Interrupt and Paging mechanism. All registers not shown and bits containing an X are assumed to be reserved.

PG[3:0]	Page Selector (Read Only). This register is used to describe Page Selector capability for extended features. Reading these bits returns 0h, which describes Page Selection as vendor specific only.
I0	INTERRUPT ENABLE (R/W). This enables interrupt generation. 0 = Interrupt Generation is Masked (Default) 1 = Interrupt Generation is Unmasked The S/W should not unmask the interrupt unless ensured by the AC '97 controller that no conflict is possible with Modem slot 12 GPI functionality. AC '97 2.2 compliant controllers will not likely support audio codec interrupt infrastructure. In that case, S/W could poll the interrupt status after initiating a sense cycle and waiting for Sense Cycle Max Delay to determine if an interrupting event has occurred.
I4	INTERRUPT STATUS (R/W). This bit provides interrupt status and clear capability. 0 = Interrupt is Clear 1 = Interrupt was Generated Interrupt event is cleared by writing a "1" to this bit. The interrupt bit will change regardless of condition of interrupt enable (I0) status. An interrupt in the GPI in slot 12 in the AC link will follow this bit change when interrupt enable (I0) is unmasked.

## Power-Down Control/Status Register (Index 26h)

Reg No.	Name	D15	D14	D13	D12	D11	D10	D9	D8	D7	D6	D5	D4	D3	D2	D1	D0	Default
26h	Power-Down Control/Status	EAPD	PR6	PR5	PR4	PR3	PR2	PR1	PR0	X	X	X	X	REF	ANL	DAC	ADC	NA

The ready bits are read only; writing to REF, ANL, DAC, ADC will have no effect. These bits indicate the status for the AD1980 subsections. If the bit is a 1, then that subsection is *ready*. *Ready* is defined as the subsection able to perform in its nominal state. All registers not shown and bits containing an X are assumed to be reserved.

ADC	ADC Sections Ready to Transmit Data
DAC	DAC Sections Ready to Transmit Data
ANL	Analog Amplifiers, Attenuators and Mixers Ready
REF	Voltage References, $V_{REF}$ and $V_{REFOUT}$ up to Nominal Level
PR[6:0]	Codec Power-Down Modes. The first three bits are to be used individually rather than in combination with each other. PR3 can be used in combination with PR2 or by itself. The mixer and reference cannot be powered down via PR3 unless the ADCs and DACs are also powered down. Nothing else can be powered up until the reference is up. PR5 has no effect unless all ADCs, DACs, and the AC-Link are powered down. The reference and the mixer can be either up or down, but all power-up sequences must be allowed to run to completion before PR5 and PR4 are both set. In multiple codec systems, the master codec's PR5 and PR4 bits control the slave codec. PR5 is also effective in the slave codec if the master's PR5 bit is clear, but the PR4 bit has no effect except to enable or disable PR5.
EAPD	External Audio Power-Down Control. Controls the state of the EAPD pin. EAPD = 0 sets the EAPD pin low, enabling an external power amplifier (reset defaults). EAPD = 1 sets the EAPD pin high, shutting off the external power amplifier.

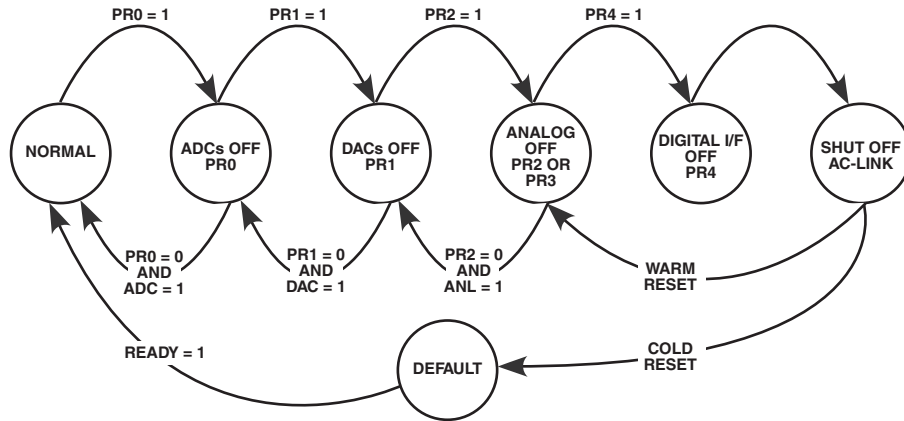

Figure 8. One Example of AC '97 Power-Down/Power-Up Flow

### Extended Audio ID Register (Index 28h)

Reg No.	Name	D15	D14	D13	D12	D11	D10	D9	D8	D7	D6	D5	D4	D3	D2	D1	D0	Default
28h	Ext'd Audio	ID1	ID0	X	X	REV1	REV0	AMAP	LDAC	SDAC	CDAC	DSA1	DSA0	X	SPDIF	DRA	VRA	X3C7h

The extended audio ID register identifies which extended audio features are supported. A nonzero extended audio ID value indicates one or more of the extended audio features are supported. All registers not shown and bits containing an X are assumed to be reserved.

VRA	Variable Rate PCM Audio Support (Read Only). This bit returns a "1" when read to indicate that the Variable Rate PCM Audio is supported.
DRA	Double Rate Audio (Read Only). This bit returns a "1" when read to indicate that the optional Double Rate RCM Audio is supported for PCM L and PCM R.
SPDIF	SPDIF Support (Read Only). This bit returns a "1" when read to indicate that the SPDIF transmitter is supported (IEC958). This bit is also used to validate that the SPDIF transmitter output is actually enabled. The SPDIF bit is only allowed to be set high if the SPDIF pin (48) is pulled down at power-up, enabling the codec transmitter logic. If the SPDIF pin is floating or pulled high at power-up, the transmitter logic is disabled and therefore this bit returns a low, indicating that the SPDIF transmitter is not available. This bit must always be read back to verify that the SPDIF transmitter is actually enabled.
DSA[1,0]	DAC Slot Assignments (Read/Write) (Reset Default = 00) 00 DACs 1, 2 = 3 and 4    DACs 3, 4 = 7 and 8    DACs 5, 6 = 6 and 9 01 DACs 1, 2 = 7 and 8    DACs 3, 4 = 6 and 9    DACs 5, 6 = disabled 10 DACs 1, 2 = 6 and 9    DACs 3, 4 = disabled    DACs 5, 6 = disabled 11 Reserved
CDAC	PCM CENTER DAC Support (Read Only). This bit returns a "1" when read to indicate that PCM center DAC is supported.
SDAC	PCM Surround DAC Support (Read Only). This bit returns a "1" when read to indicate that PCM surround left and right DACs are supported.
LDAC	PCM LFE DAC Support (Read Only), This bit returns a "1" when read to indicate that PCM LFE DAC is supported.
AMAP	Slot DAC Mappings Based on Codec ID (Read Only). This bit returns a "1" when read to indicate that slot/DAC mappings based on codec ID are supported.
REV[1,0]	REV[1,0] = 01 indicates codec is AC '97 revision 2.2 compliant (Read Only).
ID[1:0]	Indicates Codec Configuration (Read Only). 00 = Primary 01, 10, 11 = Secondary

## Extended Audio Status and Control Register (Index 2Ah)

Reg No.	Name	D15	D14	D13	D12	D11	D10	D9	D8	D7	D6	D5	D4	D3	D2	D1	D0	Default
2Ah	Extended Audio Stat/Ctrl	VFORCE	X	PRK	PRJ	PRI	SPCV	X	ELDAC	ESDAC	ECDAC	SPSA1	SPSA0	X	ESPDIF	EDRA	EVRA	0XX0h

The extended audio status and control register is a read/write register that provides status and control of the extended audio features. All registers not shown and bits containing an X are assumed to be reserved.

EVRA	Variable Rate Audio (Read/Write). VRA = 0, sets fixed sample rate audio at 48 kHz (Reset Default). VRA = 1, enables variable rate audio mode (enables sample rate registers and SLOTREQ signaling).
EDRA	Double Rate Audio. DRA = 1 enables double rate audio mode in which data from PCM L and PCM R in output slots 3 and 4 is used in conjunction with PCM L (n + 1) and PCM R (n + 1) data to provide DAC streams at twice the sample rate designated by the PCM front sample rate control register. When using the double rate audio only the front DACs are supported, and all other DACs (surround, center, and LFE) are automatically powered down. Note that DRA can be used without VRA; in that case the converter rates are forced to 96 kHz if DRA = 1.
ESPDIF	SPDIF Transmitter Subsystem Enable/Disable Bit (Read/Write). SPDIF = 1 enables the SPDIF transmitter. SPDIF = 0 disables the SPDIF transmitter (default).
SPSA[1,0]	SPDIF Slot Assignment Bits (Read/Write). These bits control the SPDIF slot assignment and respective defaults, depending on the codec ID configuration. See the following table.
ECDAC	Center DAC Status (Read Only). CDAC = 1 indicates the PCM center DAC is ready.
ESDAC	Surround DAC status (Read Only). SDAC = 1 indicates the PCM surround DACs are ready.
ELDAC	LFE DAC status (Read Only). LDAC = 1 indicates the PCM LFE DAC is ready.
SPCV	SPDIF Configuration Valid (Read Only). Indicates the status of the SPDIF transmitter subsystem, enabling the driver to determine if the currently programmed SPDIF configuration is supported. SPCV is always valid, independent of the SPDIF enable bit status. SPCV = 0 indicates current SPDIF configuration (SPSA, SPSR, DAC slot rate, DRS) is not valid (not supported). SPCV = 1 indicates current SPDIF configuration (SPSA, SPSR, DAC slot rate, DRS) is valid (supported).
PRI	Center DAC Power-Down (Read/Write). PRJ = 1 turns off the PCM Center DAC.
PRJ	Surround DACs Power-Down (Read/Write). PRJ = 1 turns off the PCM surround DACs.
PRK	LFE DAC Power-Down (Read/Write). PRJ = 1 turns off the PCM LFE DAC.
VFORCE	Validity Force Bit (Reset Default = 0). When asserted, this bit forces the SPDIF stream validity flag (Bit 28 within each SPDIF L/R subframe) to be controlled by the V bit (D15) in Register 3Ah (SPDIF control register). VFORCE = 0 and V = 0; the Validity Bit is managed by the codec error detection logic. VFORCE = 0 and V = 1; the Validity Bit is forced high, indicating subframe data is invalid. VFORCE = 1 and V = 0; the Validity Bit is forced low, indicating subframe data is valid. VFORCE = 1 and V = 1; the Validity Bit is forced high, indicating subframe data is invalid.

## AC '97 2.2 AMAP Compliant Default SPDIF Slot Assignments

Codec ID	Function	SPSA = 00	SPSA = 01	SPSA = 10	SPSA = 11
00	2-Ch Primary w/SPDIF	3 and 4	7 and 8 [default]	6 and 9	10 and 11
00	4-Ch Primary w/SPDIF	3 and 4	7 and 8	6 and 9[default]	10 and 11
00	6-Ch Primary w/SPDIF	3 and 4	7 and 8	6 and 9	10 and 11[default]
01	+2-Ch Secondary w/SPDIF	3 and 4	7 and 8	6 and 9[default]	
01	+4-Ch Secondary w/SPDIF	3 and 4	7 and 8	6 and 9	10 and 11[default]
10	+2-Ch Secondary w/SPDIF	3 and 4	7 and 8	6 and 9[default]	
10	+4-Ch Secondary w/SPDIF	3 and 4	7 and 8	6 and 9	10 and 11[default]
11	+2-Ch Secondary w/SPDIF	3 and 4	7 and 8	6 and 9	10 and 11[default]

### PCM Front DAC Rate Register (Index 2Ch)

Reg No.	Name	D15	D14	D13	D12	D11	D10	D9	D8	D7	D6	D5	D4	D3	D2	D1	D0	Default
2Ch	PCM Front DAC Rate	SRF15	SRF14	SRF13	SRF12	SRF11	SRF10	SRF9	SRF8	SRF7	SRF6	SRF5	SRF4	SRF3	SRF2	SRF1	SRF0	BB80h

This read/write Sample Rate Control Register contains 16-bit unsigned value, representing the rate of operation in Hz.

SRF[15:0]	<p>Sample Rate. The sampling frequency range is from 7 kHz (1B58h) to 48 kHz (BB80h) in 1 Hz increments. If zero is written to VRA, then the sample rate is reset to 48 kHz.</p>
-----------	--

### PCM Surround DAC Rate Register (Index 2Eh)

Reg No.	Name	D15	D14	D13	D12	D11	D10	D9	D8	D7	D6	D5	D4	D3	D2	D1	D0	Default
2Eh	PCM Surr DAC Rate	SRS15	SRS14	SRS13	SRS12	SRS11	SRS10	SRS9	SRS8	SRS7	SRS6	SRS5	SRS4	SRS3	SRS2	SRS1	SRS0	BB80h

This read/write Sample Rate Control Register contains 16-bit unsigned value, representing the rate of operation in Hz.

This register sets the sample rate for the surround DAC. This register's reset default is to be locked to the PCM front DAC sample rate register (2-Ch).

To unlock this register, Bit SRU in Register 76h must be asserted.

SRF[15:0]	<p>Sample Rate. The sampling frequency range is from 7 kHz (1B58h) to 48 kHz (BB80h) in 1 Hz increments. If zero is written to VRA bit, then the sample rate is reset to 48 kHz.</p>
-----------	--

### PCM LFE (and CENTER) DAC Rate Register (Index 30h)

Reg No.	Name	D15	D14	D13	D12	D11	D10	D9	D8	D7	D6	D5	D4	D3	D2	D1	D0	Default
30h	PCM LFE/C DAC Rate	SRCL15	SRCL14	SRCL13	SRCL12	SRCL11	SRCL10	SRCL9	SRCL8	SRCL7	SRCL6	SRCL5	SRCL4	SRCL3	SRCL2	SRCL1	SRCL0	BB80h

This read/write sample rate control register contains 16-bit unsigned value, representing the rate of operation in Hz.

This register sets the sample rate for the LFE DAC and Center DAC. This register's reset default is to be locked to the PCM Front DAC sample rate register (2-Ch).

To unlock the register bit, SRU in Register 76h must be asserted.

SRCL[15:0]	<p>Sample Rate. The sampling frequency range is from 7 kHz (1B58h) to 48 kHz (BB80h) in 1 Hz increments. If zero is written to VRA, then the sample rate is reset to 48 kHz.</p>
------------	--

### PCM ADC Rate Register (Index 32h)

Reg No.	Name	D15	D14	D13	D12	D11	D10	D9	D8	D7	D6	D5	D4	D3	D2	D1	D0	Default
32h	PCM L/R ADC Rate	SRA15	SRA14	SRA13	SRA12	SRA11	SRA10	SRA9	SRA8	SRA7	SRA6	SRA5	SRA4	SRA3	SRA2	SRA1	SRA0	BB80h

This read/write sample rate control register contains 16-bit unsigned value, representing the rate of operation in Hz.

SRA[15:0]	<p>Sample Rate. The sampling frequency range is from 7 kHz (1B58h) to 48 kHz (BB80h) in 1 Hz increments. If zero is written to VRA, then the sample rate is reset to 48 kHz.</p>
-----------	--

## CENTER/LFE Volume Control Register (Index 36h)

Reg No.	Name	D15	D14	D13*	D12	D11	D10	D9	D8	D7	D6	D5*	D4	D3	D2	D1	D0	Default
36h	Center/LFE Volume	LM	X	LFE5	LFE4	LFE3	LFE2	LFE1	LFE0	CM	X	CNT5	CNT4	CNT3	CNT2	CNT1	CNT0	8080h

All registers not shown and bits containing an X are assumed to be reserved.

Refer to Table VII for examples. This register controls the LFE output volume and mute bit. The volume registers contain five bit, generating 32 volume levels with 31 steps of 1.5 dB each. If MSPLT is not set, Bit D7 has no effect.

\*Because AC '97 defines 6-bit volume registers, to maintain compatibility, whenever the D5 or D13 bit is set to "1," its respective lower five volume bits are automatically set to "1" by the codec logic. On readback, all lower five bits will read "1"s whenever this bit is set to "1."

Note that depending on the state of the AC97NC bit in register 76h, this register operates as follows:

For AC97NC = 0, the register controls the center and LFE output pin Attenuators. Range is 0 dB to -46.5 dB.

For AC97NC = 1, the register controls the center and LFE DAC Gain/Attenuators. Range is +12 dB to -34.5 dB.

CNT[5:0]	Center Volume Control
CM	Center Volume Mute. When this bit is set to "1," the channel is muted.
LFE[5:0]	LFE Volume Control
LM	LFE Volume Mute. When this bit is set to "1," the channel is muted.

Table VII. Settings for Center/LFE Register

Control Bits CENTER and LFE Volume (36h)				
D15/D7	CENTER D[5:0] and LFE D[13:8]		Function with AC97NC = 0	Function with AC97NC = 1
	WRITE	READBACK		
0	00 0000	00 0000	0 dB Gain	12 dB Gain
0	00 1111	00 1111	-22 dB Gain	-10.5 dB Gain
0	01 1111	01 1111	-46.5 dB Gain	-34.5 dB Gain
0	1x xxxx	01 1111	-46.5 dB Gain	Not Applicable
1	xx xxxx	xx xxxx	Muted	Muted

## Surround Volume Control Register (Index 38h)

Reg No.	Name	D15	D14	D13*	D12	D11	D10	D9	D8	D7	D6	D5*	D4	D3	D2	D1	D0	Default
38h	Surround Volume	MUTE_L	X	LSR5	LSR4	LSR3	LSR2	LSR1	LSR0	MUTE_R	X	RSR5	RSR4	RSR3	RSR2	RSR1	RSR0	8080h

\*Refer to Table VIII for examples. This register controls the surround volume controls for both stereo channels and mute bits. Each volume subregister contains five bits, generating 32 volume levels with 31 steps of 1.5 dB each. Because AC '97 defines 6-bit volume registers, to maintain compatibility, whenever the D5 or D13 Bit is set to 1, its respective lower five volume bits are automatically set to "1" by the coded logic. On readback, all lower five bits will read "1s" whenever these bits are set to "1."

Note that depending on the state of the AC97NC bit in Register 0x76, this register operates as follows:

For AC97NC = 0, the register controls the surround output pin Attenuators. Range is 0 dB to -46.5 dB.

For AC97NC = 1, the register controls the surround DAC Gain/Attenuators. Range is +12 dB to -34.5 dB.

RSR[5:0]	Right Surround Volume Control
MUTE_R	Right Surround Volume Mute. When this bit is set to "1," the right channel is muted.
LSR[5:0]	Left Surround Volume Control
MUTE_L	Left Surround Volume Mute. When this bit is set to "1," the left channel is muted.

**Table VIII. Settings for Surround Register**

Control Bits Surround Volume (38h)				
D15/D7	Left Surround D[13:8]		Function with AC97NC = 0	Function with AC97NC = 1
	Right Surround D[5:0]			
	WRITE	READBACK		
0	00 0000	00 0000	0 dB Gain	12 dB Gain
0	00 1111	00 1111	-22 dB Gain	-10.5 dB Gain
0	01 1111	01 1111	-46.5 dB Gain	-34.5 dB Gain
0	1x xxxx	01 1111	-46.5 dB Gain	Not Applicable
1	xx xxxx	xx xxxx	Muted	Muted

**SPDIF Control Register (Index 3Ah)**

Reg No.	Name	D15	D14	D13	D12	D11	D10	D9	D8	D7	D6	D5	D4	D3	D2	D1	D0	Default
3Ah	SPDIF Control	V	X	SPSR1	SPSR0	L	CC6	CC5	CC4	CC3	CC2	CC1	CC0	PRE	COPY	/AUD	PRO	2000h

All registers not shown and bits containing an X are assumed to be reserved.

Register 3Ah is a read/write register that controls SPDIF functionality and manages bit fields propagated as channel status (or subframe in the V case). With the exception of V, this register should only be written to when the SPDIF transmitter is disabled (SPDIF Bit in Register 2Ah is "0"). This ensures that control and status information starts up correctly at the beginning of SPDIF transmission.

PRO	Professional. "1" indicates professional use of channel status, "0" indicates consumer.
/AUD	Non-Audio. "1" indicates data is non PCM format, "0" indicates data is PCM.
COPY	Copyright. "1" indicates copyright is asserted, "0" indicates copyright is not asserted.
PRE	Pre-emphasis. "1" indicates filter pre-emphasis is 50 $\mu$ s/15 $\mu$ s, "0" indicates pre-emphasis is none.
CC[6-0]	Category Code. Programmed according to IEC standards, or as appropriate.
L	Generation Level. Programmed according to IEC standards, or as appropriate.
SPSR[1,0]	SPDIF Transmit Sample Rate: SPSR[1:0] = "00" Transmit Sample Rate = 44.1 kHz SPSR[1:0] = "01" Reserved SPSR[1:0] = "10" Transmit Sample Rate = 48 kHz (default) SPSR[1:0] = "11" Not supported.
V	Validity. This bit affects the Validity flag (Bit 28 transmitted in each SPDIF L/R subframe) and enables the SPDIF transmitter to maintain connection during error or mute conditions. V = 1 Each SPDIF subframe (L+R) has Bit 28 set to "1." This tags both samples as invalid. V = 0 Each SPDIF subframe (L+R) has Bit 28 set to "0" for valid data and "1" for invalid data (error condition). Note that when V = 0, asserting the VFORCE bit (D15) in Register 2Ah (Ext'd Audio Stat/Ctrl) will force the Validity flag low, marking both samples as valid.

## EQ Control Register (Index 60h)

Reg No.	Name	D15	D14	D13	D12	D11	D10	D9	D8	D7	D6	D5	D4	D3	D2	D1	D0	Default
60h	EQ CTRL	EQM	X	X	X	X	X	X	X	SYM	CHS	BCA5	BCA4	BCA3	BCA2	BCA1	BCA0	8080h

All registers not shown, and bits containing an X are assumed to be reserved.

Register 60h is a read/write register that controls the Equalizer functionality and data setup. This register also contains the Biquad and Coefficient Address pointer, which is used in conjunction with the EQ Data Register (78h) to set up the equalizer coefficients. The reset default disables the Equalizer function until the coefficients can be properly set up by the software and sets the Symmetry Bit to allow equal coefficients for the left and right channels.

BCA[5,0]	<p>Biquad and Coefficient Address Pointer:</p> <p>biquad 0 coef a0 BCA[5,0] = 011011</p> <p>biquad 0 coef a1 BCA[5,0] = 011010</p> <p>biquad 0 coef a2 BCA[5,0] = 011001</p> <p>biquad 0 coef b1 BCA[5,0] = 011101</p> <p>biquad 0 coef b2 BCA[5,0] = 011100</p> <p>biquad 1 coef a0 BCA[5,0] = 100000</p> <p>biquad 1 coef a1 BCA[5,0] = 011111</p> <p>biquad 1 coef a2 BCA[5,0] = 011110</p> <p>biquad 1 coef b1 BCA[5,0] = 100010</p> <p>biquad 1 coef b2 BCA[5,0] = 100001</p> <p>biquad 2 coef a0 BCA[5,0] = 100101</p> <p>biquad 2 coef a1 BCA[5,0] = 100100</p> <p>biquad 2 coef a2 BCA[5,0] = 100011</p> <p>biquad 2 coef b1 BCA[5,0] = 100111</p> <p>biquad 2 coef b2 BCA[5,0] = 100110</p> <p>biquad 3 coef a0 BCA[5,0] = 101010</p> <p>biquad 3 coef a1 BCA[5,0] = 101001</p> <p>biquad 3 coef a2 BCA[5,0] = 101000</p> <p>biquad 3 coef b1 BCA[5,0] = 101100</p> <p>biquad 3 coef b2 BCA[5,0] = 101011</p> <p>biquad 4 coef a0 BCA[5,0] = 101111</p> <p>biquad 4 coef a1 BCA[5,0] = 101110</p> <p>biquad 4 coef a2 BCA[5,0] = 101101</p> <p>biquad 4 coef b1 BCA[5,0] = 110001</p> <p>biquad 4 coef b2 BCA[5,0] = 110000</p> <p>biquad 5 coef a0 BCA[5,0] = 110100</p> <p>biquad 5 coef a1 BCA[5,0] = 110011</p> <p>biquad 5 coef a2 BCA[5,0] = 110010</p> <p>biquad 5 coef b1 BCA[5,0] = 110110</p> <p>biquad 5 coef b2 BCA[5,0] = 110101</p> <p>biquad 6 coef a0 BCA[5,0] = 111001</p> <p>biquad 6 coef a1 BCA[5,0] = 111000</p> <p>biquad 6 coef a2 BCA[5,0] = 110111</p> <p>biquad 6 coef b1 BCA[5,0] = 111011</p> <p>biquad 6 coef b2 BCA[5,0] = 111010</p>
CHS	<p>Channel Select.</p> <p>CHS = 0 selects left channel coefficients data block.</p> <p>CHS = 1 selects right channel coefficients data block.</p>
SYM	<p>Symmetry.</p> <p>When set to "1," this bit indicates that the left and right channel coefficients are equal. This shortens the coefficients' setup sequence since only the left channel coefficients need to be addressed and set up. (The right channel coefficients are fetched from the left channel memory.)</p>
EQM	<p>Equalizer Mute.</p> <p>When set to "1," this bit disables the equalizer function (allows all data pass through). The reset default sets this bit to "1," disabling the equalizer function until the biquad coefficients can be properly set.</p>

## EQ Data Register (Index 62h)

Reg No.	Name	D15	D14	D13	D12	D11	D10	D9	D8	D7	D6	D5	D4	D3	D2	D1	D0	Default
62h	EQ DATA	CFD15	CFD14	CFD13	CFD12	CFD11	CFD10	CFD9	CFD8	CFD7	CFD6	CFD5	CFD4	CFD3	CFD2	CFD1	CFD0	0000h

This read/write register is used to transfer EQ biquad coefficients into memory. The register data is transferred to, or retrieved from, the address pointed to by the BCA Bits in the EQ CNTRL register (60h). Data will only be written to memory if the EQM bit (Register 60h, Bit 15) is asserted.

CFD[15,0]	Coefficient Data. The biquad coefficients are fixed-point format values with 16 bits of resolution. The CFD15 bit is the MSB and the CFD0 bit is the LSB.
-----------	---

## Jack Sense/Audio Interrupt Status Register (Index 72h)

Reg No.	Name	D15	D14	D13	D12	D11	D10	D9	D8	D7	D6	D5	D4	D3	D2	D1	D0	Default
72h	Jack Sense	JS1 SPRD	JS1 DMX	JS0 DMX	JS MT2	JS MT1	JS MT0	JS1 EQB	JS0 EQB	JS1 TMR	JS0 TMR	JS1 MD	JS0 MD	JS1 ST	JS0 ST	JS1 INT	JS0 INT	0000h

All register bits are read/write except for JS0ST and JS1ST, which are read only.

JS0INT	Indicates Pin JS0 has generated an interrupt. Remains set until the software services JS0 interrupt, i.e., JS0 ISR should clear this bit by writing a “0” to it. Note that the interrupt to the system is actually an OR combination of this bit and JS1INT. Also, note that the actual interrupt implementation is selected by the INTS bit (Register 76h). It is also possible to generate a software system interrupt by writing a “1” to this bit.
JS1INT	Indicates Pin JS1 has generated an interrupt. Remains set until the software services JS1 interrupt, i.e., JS1 ISR should clear this bit by writing a “0” to it. See the JS0INT description for additional details.
JS0ST	JS0 STATE. This bit always reports the logic state of JS0 pin.
JS1ST	JS1 STATE. This bit always reports the logic state of JS1 pin.
JS0MD	JS0 Mode. This bit selects the operation mode for the JS0 pin. 0 = Jack Sense Mode (reset default) 1 = Interrupt Mode
JS1MD	JS1 Mode. This bit selects the operation mode for the JS1 pin. 0 = Jack Sense Mode (reset default) 1 = Interrupt Mode
JS0TMR	JS0 Timer Enable. If this bit is set to a “1,” JS0 must be high for greater than 278 ms to be recognized.
JS1TMR	JS1 Timer Enable. If this bit is set to a “1,” JS1 must be high for greater than 278 ms to be recognized.
JS0EQB	JS0 EQ Bypass Enable. This bit enables JS0 to control the EQ bypass. When this bit is set to “1,” JS0 = 1 will cause the EQ to be bypassed.
JS1EQB	JS1 EQ Bypass Enable. This bit enables JS1 to control the EQ bypass. When this bit is set to “1,” JS1 = 1 will cause the EQ to be bypassed.
JSMT[2,0]	JS Mute Enable Selector. These three bits select and enable the Jack Sense muting action (see Table IX).
JS0DMX	JS0 Down = Mix Control Enable. This bit enables JS0 to control the Down-Mix function. This function allows a digital mix of six channels of audio into 2-channel audio. The mix can then be routed to the stereo Line_out or HP_out jacks. When this bit is set to “1,” JS0 = 1 will activate the Down-Mix conversion. See the DMIX description in Register 76h. The DMIX bits select the Down-Mix implementation type and can also force the function to be activated.
JS1DMX	JS1 Down Mix Control Enable. This bit enables 2-channel to 6-channel audio Spread function when both Jack Senses are active (logic state “1”). Note that the SPRD bit can also force the Spread function without being gated by the Jack Senses. See this bit’s description in Register 76h for a better understanding of the Spread function.
JSSPRD	JS Spread Control Enable. This bit enables 2-channel to 6-channel audio Spread function when both Jack Senses are active (logic state “1”). Note that the SPRD bit can also force the Spread function without being gated by the Jack Senses. See this bit’s description in Register 76h for a better understanding of the Spread function.

Table IX. Jack Sense Mute Select (JSMT [2:0])

REF	JS1	JS0	JSMT2	JSMT1	JSMT0	HP OUT	LINE OUT	C/LFE OUT	MONO OUT	NOTES
0	OUT (0)	OUT (0)	0	0	0	ACTIVE	ACTIVE	ACTIVE	ACTIVE	JS0 and JS1 ignored
1	OUT (0)	IN (1)	0	0	0	ACTIVE	ACTIVE	ACTIVE	ACTIVE	
2	IN (1)	OUT (0)	0	0	0	ACTIVE	ACTIVE	ACTIVE	ACTIVE	
3	IN (1)	IN (1)	0	0	0	ACTIVE	ACTIVE	ACTIVE	ACTIVE	
4	OUT (0)	OUT (0)	0	0	1	ACTIVE	FMUTE	FMUTE	ACTIVE	JS0 no mute action, JS1 mutes mono and enables LINE_OUT and C/LFE. Standard 6-channel config swapped HP_OUT and LINE_OUT.
5	OUT (0)	IN (1)	0	0	1	ACTIVE	FMUTE	FMUTE	ACTIVE	
6	IN (1)	OUT (0)	0	0	1	ACTIVE	ACTIVE	ACTIVE	ACTIVE	
7	IN (1)	IN (1)	0	0	1	ACTIVE	ACTIVE	ACTIVE	ACTIVE	
8	OUT (0)	OUT (0)	0	1	0	FMUTE	ACTIVE	FMUTE	ACTIVE	
9	OUT (0)	IN (1)	0	1	0	FMUTE	ACTIVE	FMUTE	ACTIVE	
10	IN (1)	OUT (0)	0	1	0	ACTIVE	ACTIVE	ACTIVE	FMUTE	
11	IN (1)	IN (1)	0	1	0	ACTIVE	ACTIVE	ACTIVE	FMUTE	Standard 6-channel config no swap.
12	OUT (0)	OUT (0)	0	1	1	**	**	**	**	** Reserved
13	OUT (0)	IN (1)	0	1	1	**	**	**	**	
14	IN (1)	OUT (0)	0	1	1	**	**	**	**	
15	IN (1)	IN (1)	0	1	1	**	**	**	**	
16	OUT (0)	OUT (0)	1	0	0	ACTIVE	FMUTE	FMUTE	ACTIVE	JS0 = 0 and JS1 = 0 enables mono. JS1 = 1 enables front only. JS0 = 1 enables all rear. 6-chan config with front jack wrap back.
17	OUT (0)	IN (1)	1	0	0	ACTIVE	ACTIVE	ACTIVE	FMUTE	
18	IN (1)	OUT (0)	1	0	0	ACTIVE	FMUTE	FMUTE	FMUTE	
19	IN (1)	IN (1)	1	0	0	ACTIVE	FMUTE	FMUTE	FMUTE	
20	OUT (0)	OUT (0)	1	0	1	FMUTE	FMUTE	FMUTE	ACTIVE	JS0 no mute action, JS1 mutes mono and enables LINE_OUT + HP_OUT + C/LFE. Standard 6-channel config swapped HP_OUT and LINE_OUT.
21	OUT (0)	IN (1)	1	0	1	FMUTE	FMUTE	FMUTE	FMUTE	
22	IN (1)	OUT (0)	1	0	1	ACTIVE	ACTIVE	ACTIVE	FMUTE	
23	IN (1)	IN (1)	1	0	1	ACTIVE	ACTIVE	ACTIVE	FMUTE	
24	OUT (0)	OUT (0)	1	1	0	**	**		**	** Reserved
25	OUT (0)	IN (1)	1	1	0	**	**		**	
26	IN (1)	OUT (0)	1	1	0	**	**		**	
27	IN (1)	IN (1)	1	1	0	**	**		**	
28	OUT (0)	OUT (0)	1	1	1	**	**		**	** Reserved
29	OUT (0)	IN (1)	1	1	1	**	**		**	
30	IN (1)	OUT (0)	1	1	1	**	**		**	
31	IN (1)	IN (1)	1	1	1	**	**		**	

FMUTE = Output is forced to mute independent of the respective Volume Register setting.

ACTIVE = Output is not muted and its status is dependent on the respective Volume Register setting.

OUT = Nothing plugged into the jack and therefore the JS status is "0" (via the load resistor pull-down).

IN = Jack has plug inserted and therefore the JS status is "1" (via the codec JS internal pull-up).

# AD1980

## Serial Configuration Register (Index 74h)

Reg No.	Name	D15	D14	D13	D12	D11	D10	D9	D8	D7	D6	D5	D4	D3	D2	D1	D0	Default
74h	Serial Configuration	SLOT16	REGM2	REGM1	REGM0	REGM3	DRF	X	CHEN	X	LBKS1	LBKS0	INTS	X	SPAL	SPDZ	SPLNK	1001h

All registers not shown and bits containing an X are assumed to be reserved.

Note that this register is not reset when the reset register (0x00) is written to (soft reset).

SPLNK	SPDIF Link. This bit enables the SPDIF to link with the front DACs for data requesting. 0 = SPDIF and DAC are not linked. 1 = SPDIF and DAC are linked and receive the same data requests (reset default).
SPDZ	SPDIF DACZ. 0 = Repeat last sample out of the SPDIF stream if FIFO under-runs (reset default). 1 = Forces midscale sample out the SPDIF stream if FIFO under-runs.
SPAL	SPDIF ADC Loop-around. 0 = SPDIF transmitter is connected to the AC-Link stream (reset default). 1 = SPDIF transmitter is connected to the digital ADC stream, not the AC-Link.
INTS	Interrupt Mode Select. This bit selects the JS interrupt implementation path. 0 = Bit 0 SLOT 12 (modem interrupt) (reset default). 1 = Slot 6 Valid Bit (MIC ADC interrupt).
LBKS[1:0]	Loop-Back Selection. These bits select the internal digital loop-back path when LPBK bit is active (see Register 20h) 00 = Loop back through the front DACs (reset default). 01 = Loop back through the surround DACs. 10 = Reserved 11 = Loop-back through the center and LFE DACs (Center DAC loops back from the ADC left channel, the LFE DAC from the ADC right channel).
CHEN	Chain Enable. This bit enables chaining of a slave codec SDATA_IN stream into the ID0 pin (Pin 45). 0 = Disable chaining (reset default). 1 = Enable chaining into ID0 pin.
DRF	DAC Request Force. This allows the AD1980 to synchronize DAC requests with the AD1981A/B. 0 = Normal DAC requesting sequence (reset default). 1 = Synchronize to AD1981A/B DAC requests.
REGM3	Slave 3 Codec Register Mask
REGM0	Master Codec Register Mask
REGM1	Slave 1 Codec Register Mask
REGM2	Slave 2 Codec Register Mask
SLOT16	Enable 16-Bit Slot Mode. SLOT16 makes all ac-link slots 16 bits in length, formatted into 16 slots. This is a preferred mode for DSP serial port interfacing.

## Miscellaneous Control Bit Register (Index 76h)

Reg No.	Name	D15	D14	D13	D12	D11	D10	D9	D8	D7	D6	D5	D4	D3	D2	D1	D0	De- fault
76th	Misc Control Bits	DACZ	AC97NC	MSPLT	LODIS	CLDIS	HPSEL	DMIX1	DMIX0	SPRD	2CMIC	LOSEL	SRU	VREFH	VREFD	MBG1	MBG0	0000h

MBG[1:0]	<p>MIC Boost Gain Select Register.</p> <p>These two bits allow changing the MIC preamp gain from the nominal 20 dB gain. Both MIC1/MIC2 and MIC2 preamps will be set to the same selected gain.</p> <p>Note that this gain takes effect only while Bit D6 (M20) on the MIC volume register (0Eh) is set to 1; otherwise the MIC boost block has a gain of 0 dB.</p> <p>00 = 20 dB gain (reset default)  01 = 10 dB gain  10 = 30 dB gain  11 = reserved</p>
VREFD	<p><math>V_{REFOUT}</math> Disable. Disables <math>V_{REFOUT}</math>, placing it into High Z out mode.</p> <p>Note that this bit overrides the VREFH bit selection (see below).</p> <p>0 = <math>V_{REFOUT}</math> pin is driven by the internal reference (reset default).  1 = <math>V_{REFOUT}</math> pin is placed into High Z out mode.</p>
VREFH	<p><math>V_{REFOUT}</math> High. Changes <math>V_{REFOUT}</math> from 2.25 V to 3.70 V for PC2001 compliant MIC bias applications.</p> <p>0 = <math>V_{REFOUT}</math> pin is set to 2.25 V output (reset default).  1 = <math>V_{REFOUT}</math> pin is set to 3.70 V output.</p>
SRU	<p>Sample Rate Unlock. Controls DAC sample rate locking.</p> <p>0 = All DAC Sample Rates are locked to the front sample rate (reset default).  1 = DAC sample rates can be set independently for front, surround, and LFE.</p>
LOSEL	<p>LINE_OUT Amplifiers Input Select. This bit allows the LINE_OUT output amplifiers to be driven by the mixer or the surround DACs. The main purpose for this is to allow swapping of the front and surround channels to make better use of the SURR/HP_OUT output amplifiers. This bit should normally be used in tandem with the HPSEL bit (see below).</p> <p>0 = LINE_OUT amplifiers are driven by the mixer outputs (reset default).  1 = LINE_OUT amplifiers are driven by the surround DAC outputs.</p>
2CMIC	<p>2-Channel MIC Select. This bit enables simultaneous recording from MIC1 and MIC2 inputs, using a stereo microphone array. Note that this register works in conjunction with the MS bit in Register 20h.</p> <p>0 = MIC1 or MIC2 (determined by MS bit) is routed to the record selector's left and right MIC channels as well as to the mixer (reset default).  1 = MIC1 is routed to the record selector's left MIC channel and MIC2 is routed to the record selector's right MIC channel. Note that in this mode, the MS bit should be set low and MIC1 can still be enabled into the mixer.</p>
SPRD	<p>SPREAD Enable. This bit enables spreading of 2-channel media to all six output channels. This function is implemented in the analog section by using the output selector controls line for the center/LFE, surround, and Line_out output channels. Note that the Jack Sense pins can also be set up to control (gate) this function, depending on the JSSPRD bit (see Register 72h).</p> <p>0 = No spreading occurs unless activated by the Jack Senses and JSSPRD bits (reset default).  1 = The SPRD selector drives the center and LFE outputs from the MONO_OUT, the HPSEL selector drives the SURR/HP_OUT outputs from the mixer outputs, and the LOSEL selector drives the LINE_OUT outputs also from the mixer outputs.</p> <p>Note that the SPRD bit overrides the current output selector control lines set up by bits LOSEL and HPSEL as follows: LOSEL = 0 and HPSEL = 1.</p>

# AD1980

DMIX[1:0]	<p>Down Mix Mode Select. Provides analog down-mixing of the center, LFE, and/or surround channels into the mixer channels. This allows the full content of 5.1 or quad media to be played through stereo headphones or speakers.</p> <p>Note that the Jack Sense pins can also be set up to control (gate) this function depending on the JS0DMX and JS1DMX Bits (see Register 72h).</p> <p>The upper bit allows forcing the down-mix function:  DMIX[1] = 0, no down-mix unless activated by the Jack Sense and JSxDMX bits (default).  DMIX[1] = 1, forces down-mix function.</p> <p>The lower bit selects the down-mix type:  DMIX[0] = 0, selects 6-to-4 down-mix. The center and LFE channels are summed equally into the mixer left and right channels (default).  DMIX[0] = 1, selects 6-to-2 down-mix. The surround left and right channels are summed into the mixer left and right channels.</p> <p>Default for DMIX[1:0] is “00.”</p>
HPSEL	<p>Headphone Amplifier Input Select. This bit allows the headphone power amps to be driven from the surround DACs or from the mixer outputs. There are two reasons for this: one is to allow 2-channel media to use the higher power headphone amplifiers available on the SURR/HP_OUT outputs; the other is to allow spreading of 2-channel media to the surround outputs.</p> <p>Together with the LOSEL bit (see above), this bit also provides for analog swapping of the mixer (front) and surround outputs.</p> <p>0 = SURR_out/HP_out outputs are driven by the surround DACs (reset default).  1 = SURR_out/HP_out outputs are driven by the mixer outputs.</p>
CLDIS	<p>Center and LFE Disable. Disables the center and LFE output pins, placing them into High-Z mode so that the assigned output audio jack(s) can be shared for MIC inputs or other functions.</p> <p>0 = Center and LFE output pins have normal audio drive capability (reset default).  1 = Center and LFE output pins are placed into High-Z mode.</p>
LODIS	<p>Line_out Disable. Disables the Line_out pins (L/R), placing them into High-Z mode so that the assigned output audio jack can be shared for Line Input function.</p> <p>0 = Line_out pins have normal audio drive capability (reset default).  1 = Line_out pins are placed into High-Z mode.</p>
MSPLT	<p>Mute Split. Allows separate mute control bits for master, HP, Line_in, CD, PCM OUT, and record volume/gain control registers.</p> <p>0 = Both left and right channel mutes are controlled by Bit D15 in the respective registers (reset default).  1 = Bit D15 affects only the left channel mute and Bit D7 affects only the right channel mute.</p>
AC97NC	<p>AC '97 No Compatibility Mode. This bit allows the surround, center, and LFE volume control registers and output attenuators to operate in a more functional mode than defined by the AC97 2.2 spec. This is called ADI compatibility mode.</p> <p>In AC '97 compatibility mode, the DAC Gain/Attenuators for the surround, center, and LFE are controlled by Register 18h (PCM volume). The output pin attenuators for the surround are controlled by Register 38h, and the output pin attenuators for the center and LFE are controlled by Register 36h.</p> <p>In ADI compatibility mode, the Surround DAC Gain/Attenuators are controlled by Register 38h, and the Center/LFE DAC are controlled by Register 36h.</p> <p>The output pin attenuators for Center/LFE are controlled by Register 02h (Master Volume), and the output pin attenuators for Surround are controlled by Register 04h.</p> <p>0 = AC97 compatibility mode (reset default).  1 = ADI compatibility mode.</p>
DACZ	<p>DAC Zero-Fill. Determines DAC data fill under starved condition.</p> <p>0 = DAC data is repeated when DACs are starved for data (reset default).  1 = DAC data is zero-filled when DACs are starved for data.</p>

## Vendor ID Register (Index 7Ch–7Eh)

Reg No.	Name	D15	D14	D13	D12	D11	D10	D9	D8	D7	D6	D5	D4	D3	D2	D1	D0	Default
7Ch	Vendor ID1	F7	F6	F5	F4	F3	F2	F1	F0	S7	S6	S5	S4	S3	S2	S1	S0	4144h

S[7:0] This register is ASCII encoded to A.

F[7:0] This register is ASCII encoded to D.

Reg No.	Name	D15	D14	D13	D12	D11	D10	D9	D8	D7	D6	D5	D4	D3	D2	D1	D0	Default
7Eh	Vendor ID2	T7	T6	T5	T4	T3	T2	T1	T0	REV7	REV6	REV5	REV4	REV3	REV2	REV1	REV0	5370h

T[7:0] This register is ASCII encoded to S.

REV[7:0] This register is set to 70h identifying the AD1980.

## Codec ID and Clock Selection Table

XTL_IN	ID1#	IDO#	Codec ID	Codec Clocking Source
GND	0	0	SECONDARY, ID = 3	12.288 MHz (BIT_CLK from Primary Codec)
GND	0	1	SECONDARY, ID = 2	12.288 MHz (BIT_CLK from Primary Codec)
GND	1	0	SECONDARY, ID = 1	12.288 MHz (BIT_CLK from Primary Codec)
XTAL	1	1	PRIMARY, ID = 0	24.576 MHz Local XTAL or External CLK
into XTL_IN				
CLK INPUT	0	0	PRIMARY, ID = 0	14.3181 MHz (External into XTL_IN)
CLK INPUT	0	1	PRIMARY, ID = 0	48.00 MHz (External into XTL_IN)
CLK INPUT	1	X	RESERVED	RESERVED

Note that internally, the  $\overline{ID}$  pins have weak pull-ups and are inverted.

OUTLINE DIMENSIONS

48-Lead Plastic Quad Flatpack [LQFP]  
 1.4 mm Thick  
 (ST-48)

Dimensions shown in millimeters

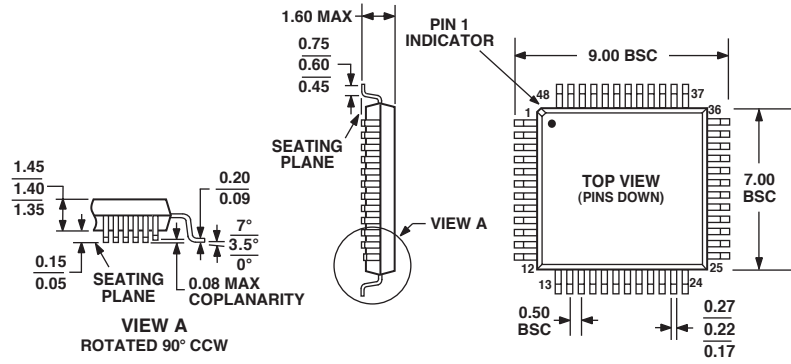

COMPLIANT TO JEDEC STANDARDS MS-026BBC





## Looking for pricing, stock, or lifecycle information?

Click below to explore more details on WIN SOURCE:

 [View AD1980JST-REEL on WIN SOURCE](#)

 [Analog Devices Inc. Information](#)

## Optimize Your Supply Chain with WIN SOURCE Solutions

-  Global Sourcing Solution
-  Obsolete Management
-  Cost Control Management
-  Shortage Management
-  Alternative Solution
-  Excess Inventory Management