



## TRIS3232E 3-V to 5.5-V Multichannel RS-232 Line Driver and Receiver With ±15-kV IEC ESD Protection

### 1 Features

- ESD Protection for RS-232 Bus Pins
  - ±15 kV (HBM)
  - ±8 kV (IEC61000-4-2, Contact Discharge)
  - ±15 kV (IEC61000-4-2, Air-Gap Discharge)
- Meets or Exceeds the Requirements of TIA/EIA-232-F and ITU V.28 Standards
- Operates With 3-V to 5.5-V  $V_{CC}$  Supply
  - Interoperable with RS-232 down to 2.7-V  $V_{CC}$
- Operates up to 250 kbps
- Two Drivers and Two Receivers
- Low Supply Current: 300  $\mu$ A (Typical)
- External Capacitors: 4  $\times$  0.1  $\mu$ F
- Accepts 5-V Logic Input With 3.3-V Supply
- Pin Compatible to Alternative High-Speed Devices (1 Mbps)
  - SN65C3232E (–40°C to +85°C)
  - SN75C3232E (0°C to 70°C)

### 2 Applications

- Battery-Powered Systems
- Notebooks
- Laptops
- Palmtop PCs
- Hand-Held Equipment

### 3 Description

The TRIS3232E device consists of two line drivers, two-line receivers, and a dual charge-pump circuit with ±15-kV IEC ESD protection pin to pin (serial-port connection pins, including GND).

The device meets the requirements of TIA/EIA-232-F and provides the electrical interface between an asynchronous communication controller and the serial-port connector. The charge pump and four small external capacitors allow operation from a single 3-V to 5.5-V supply. The devices operate at data signaling rates up to 250 kbps and a maximum of 30-V/ $\mu$ s driver output slew rate.

#### Device Information<sup>(1)</sup>

| PART NUMBER | PACKAGE         | BODY SIZE (NOM)           |
|-------------|-----------------|---------------------------|
| TRIS3232E   | SOIC (D) (16)   | 9.90 mm $\times$ 3.91 mm  |
|             | SSOP (DB) (16)  | 6.20 mm $\times$ 5.30 mm  |
|             | SOIC (DW) (16)  | 10.30 mm $\times$ 7.50 mm |
|             | TSSOP (PW) (16) | 5.00 mm $\times$ 4.40 mm  |

(1) For all available packages, see the orderable addendum at the end of the data sheet.

#### Simplified Diagram

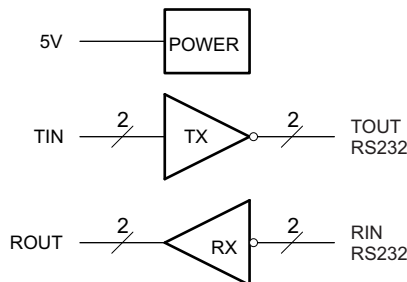

## Table of Contents

|  |          |  |           |
|--|----------|--|-----------|
| <b>1 Features</b> .....                          | <b>1</b> | 8.1 Overview .....   | <b>8</b>  |
| <b>2 Applications</b> .....                      | <b>1</b> | 8.2 Functional Block Diagram .....                               | <b>8</b>  |
| <b>3 Description</b> .....                       | <b>1</b> | 8.3 Feature Description .....                                    | <b>8</b>  |
| <b>4 Revision History</b> .....                  | <b>2</b> | 8.4 Device Functional Modes .....                                | <b>9</b>  |
| <b>5 Pin Configuration and Functions</b> .....   | <b>3</b> | <b>9 Application and Implementation</b> .....                    | <b>10</b> |
| <b>6 Specifications</b> .....                    | <b>4</b> | 9.1 Application Information .....                                | <b>10</b> |
| 6.1 Absolute Maximum Ratings .....               | <b>4</b> | 9.2 Typical Application .....                                    | <b>10</b> |
| 6.2 ESD Ratings .....                            | <b>4</b> | <b>10 Power Supply Recommendations</b> .....                     | <b>12</b> |
| 6.3 Recommended Operating Conditions .....       | <b>4</b> | <b>11 Layout</b> .....   | <b>12</b> |
| 6.4 Thermal Information .....                    | <b>5</b> | 11.1 Layout Guidelines .....                                     | <b>12</b> |
| 6.5 Electrical Characteristics — Device .....    | <b>5</b> | 11.2 Layout Example .....  | <b>12</b> |
| 6.6 Electrical Characteristics — Driver .....    | <b>5</b> | <b>12 Device and Documentation Support</b> .....                 | <b>13</b> |
| 6.7 Electrical Characteristics — Receiver .....  | <b>5</b> | 12.1 Community Resources .....                                   | <b>13</b> |
| 6.8 Switching Characteristics .....              | <b>6</b> | 12.2 Trademarks .....  | <b>13</b> |
| 6.9 Typical Characteristics .....                | <b>6</b> | 12.3 Electrostatic Discharge Caution .....                       | <b>13</b> |
| <b>7 Parameter Measurement Information</b> ..... | <b>7</b> | 12.4 Glossary .....  | <b>13</b> |
| <b>8 Detailed Description</b> .....              | <b>8</b> | <b>13 Mechanical, Packaging, and Orderable Information</b> ..... | <b>13</b> |

## 4 Revision History

NOTE: Page numbers for previous revisions may differ from page numbers in the current version.

| <b>Changes from Revision A (July 2015) to Revision B</b>                | <b>Page</b> |
|---|-------------|
| • Added Feature: Interoperable with RS-232 down to 2.7-V $V_{CC}$ ..... | <b>1</b>    |
| • Added <a href="#">Figure 3</a> .....                                  | <b>6</b>    |

| <b>Changes from Original (April 2007) to Revision A</b>   | <b>Page</b> |
|---|-------------|
| • Deleted <i>Ordering Information</i> table. ....   | <b>1</b>    |
| • Added <i>Device Information</i> table, <i>Pin Configuration and Functions</i> section, <i>ESD Ratings</i> table, <i>Thermal Information</i> table, <i>Feature Description</i> section, <i>Device Functional Modes</i> , <i>Application and Implementation</i> section, <i>Power Supply Recommendations</i> section, <i>Layout</i> section, <i>Device and Documentation Support</i> section, and <i>Mechanical, Packaging, and Orderable Information</i> section ..... | <b>1</b>    |

## 5 Pin Configuration and Functions

**D, DW, DB or PW Package  
16-Pin SOIC, SSOP or TSSOP  
Top View**

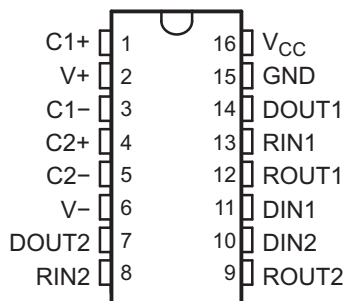

### Pin Functions

| PIN             |     | I/O | DESCRIPTION   |
|-----------------|-----|-----|---|
| NAME            | NO. |     |   |
| C1+             | 1   | —   | Positive lead of C1 capacitor                                 |
| C1-             | 3   | —   | Negative lead of C1 capacitor                                 |
| C2+             | 4   | —   | Positive lead of C2 capacitor                                 |
| C2-             | 5   | —   | Negative lead of C2 capacitor                                 |
| DIN1            | 11  | I   | Logic data input (from UART)                                  |
| DIN2            | 10  | I   | Logic data input (from UART)                                  |
| DOUT2           | 7   | O   | RS232 line data output (to remote RS232 system)               |
| DOUT1           | 14  | O   | RS232 line data output (to remote RS232 system)               |
| GND             | 15  | —   | Ground  |
| RIN1            | 13  | I   | RS232 line data input (from remote RS232 system)              |
| RIN2            | 8   | I   | RS232 line data input (from remote RS232 system)              |
| ROUT2           | 9   | O   | Logic data output (to UART)                                   |
| ROUT1           | 12  | O   | Logic data output (to UART)                                   |
| V+              | 2   | O   | Positive charge pump output for storage capacitor only        |
| V-              | 6   | O   | Negative charge pump output for storage capacitor only        |
| V <sub>CC</sub> | 16  | —   | Supply voltage, connect to external 3-V to 5.5-V power supply |

## 6 Specifications

### 6.1 Absolute Maximum Ratings

over operating free-air temperature range (unless otherwise noted)<sup>(1)</sup>

|                  |   | MIN       | MAX   | UNIT                  |   |
|------------------|---|-----------|-------|-----------------------|---|
| V <sub>CC</sub>  | Supply voltage <sup>(2)</sup>                 | -0.3      | 6     | V                     |   |
| V+               | Positive output supply voltage <sup>(2)</sup> | -0.3      | 7     | V                     |   |
| V-               | Negative output supply voltage <sup>(2)</sup> | 0.3       | -7    | V                     |   |
| V+ - V-          | Supply voltage difference <sup>(2)</sup>      |           | 13    | V                     |   |
| V <sub>I</sub>   | Input voltage                                 | Drivers   | -0.3  | 6                     | V |
|                  |   | Receivers | -25   | 25                    | V |
| V <sub>O</sub>   | Output voltage                                | Drivers   | -13.2 | 13.2                  | V |
|                  |   | Receivers | -0.3  | V <sub>CC</sub> + 0.3 | V |
| T <sub>J</sub>   | Operating virtual junction temperature        |           | 150   | °C                    |   |
| T <sub>stg</sub> | Storage temperature                           | -65       | 150   | °C                    |   |

(1) Stresses beyond those listed under *Absolute Maximum Ratings* may cause permanent damage to the device. These are stress ratings only, and functional operation of the device at these or any other conditions beyond those indicated under *Recommended Operating Conditions* is not implied. Exposure to absolute-maximum-rated conditions for extended periods may affect device reliability.

(2) All voltages are with respect to network GND.

### 6.2 ESD Ratings

|                    |                         |  | VALUE                            | UNIT   |   |
|--------------------|-------------------------|--|----------------------------------|--------|---|
| V <sub>(ESD)</sub> | Electrostatic discharge | Human body model (HBM), per ANSI/ESDA/JEDEC JS-001 <sup>(1)</sup>              | All pins except 7, 8, 14, and 14 | ±2000  | V |
|                    |                         |  | Pins 7, 8, 14, and 14            | ±15000 |   |
|                    |                         | Charged-device model (CDM), per JEDEC specification JESD22-C101 <sup>(2)</sup> | All pins                         | ±1500  |   |
|                    |                         | IEC61000-4-2, Contact Discharge  | Pins 7, 8, 14, and 14            | ±8000  |   |
|                    |                         | IEC61000-4-2, Air-Gap Discharge  | Pins 7, 8, 14, and 14            | ±15000 |   |

(1) JEDEC document JEP155 states that 500-V HBM allows safe manufacturing with a standard ESD control process.

(2) JEDEC document JEP157 states that 250-V CDM allows safe manufacturing with a standard ESD control process.

### 6.3 Recommended Operating Conditions

See [Figure 8](#).<sup>(1)</sup>

|   |                         | MIN                     | NOM | MAX | UNIT |
|---|-------------------------|-------------------------|-----|-----|------|
| Supply voltage                                  | V <sub>CC</sub> = 3.3 V | 3                       | 3.3 | 3.6 | V    |
|   | V <sub>CC</sub> = 5 V   | 4.5                     | 5   | 5.5 |      |
| V <sub>IH</sub> Driver high-level input voltage | DIN                     | V <sub>CC</sub> = 3.3 V | 2   | 5.5 | V    |
|   |                         | V <sub>CC</sub> = 5 V   | 2.4 | 5.5 |      |
| V <sub>IL</sub> Driver low-level input voltage  | DIN                     | 0                       |     | 0.8 | V    |
| V <sub>I</sub> Receiver input voltage           | RIN                     | -25                     |     | 25  | V    |
| T <sub>A</sub> Operating free-air temperature   | TRS3232EC               | 0                       |     | 70  | °C   |
|   | TRS3232EI               | -40                     |     | 85  |      |

(1) C1–C4 = 0.1 μF at V<sub>CC</sub> = 3.3 V ± 0.3 V; C1 = 0.047 μF, C2–C4 = 0.33 μF at V<sub>CC</sub> = 5 V ± 0.5 V.

## 6.4 Thermal Information

| THERMAL METRIC <sup>(1)</sup> | TRS3232E                                     |          |           |           | UNIT |      |
|-------------------------------|--|----------|-----------|-----------|------|------|
|                               | PW (TSSOP)                                   | D (SOIC) | DW (SOIC) | DB (SSOP) |      |      |
|                               | 16 PINS                                      | 16 PINS  | 16 PINS   | 16 PINS   |      |      |
| R <sub>θJA</sub>              | Junction-to-ambient thermal resistance       | 99.3     | 76.1      | 72.3      | 90.9 | °C/W |
| R <sub>θJctop</sub>           | Junction-to-case (top) thermal resistance    | 20.8     | 36.7      | 33.5      | 36.2 | °C/W |
| R <sub>θJB</sub>              | Junction-to-board thermal resistance         | 45.1     | 33.6      | 37.1      | 43.8 | °C/W |
| ψ <sub>JT</sub>               | Junction-to-top characterization parameter   | 0.6      | 4.2       | 7.5       | 4.2  | °C/W |
| ψ <sub>JB</sub>               | Junction-to-board characterization parameter | 45.1     | 33.3      | 37.1      | 42.9 | °C/W |
| R <sub>θJcbot</sub>           | Junction-to-case (bottom) thermal resistance | –        | –         | –         | –    | °C/W |

(1) For more information about traditional and new thermal metrics, see the *Semiconductor and IC Package Thermal Metrics* application report, [SPRA953](#).

## 6.5 Electrical Characteristics — Device

over recommended ranges of supply voltage and operating free-air temperature (unless otherwise noted) (see [Figure 8](#)).<sup>(1)</sup>

| PARAMETER       | TEST CONDITIONS | MIN                                     | TYP <sup>(2)</sup> | MAX | UNIT |    |
|-----------------|-----------------|---|--------------------|-----|------|----|
| I <sub>CC</sub> | Supply current  | No load, V <sub>CC</sub> = 3.3 V or 5 V |                    | 0.3 | 1    | mA |

(1) Test conditions are C1–C4 = 0.1 μF at V<sub>CC</sub> = 3.3 V ± 0.3 V; C1 = 0.047 μF, C2–C4 = 0.33 μF at V<sub>CC</sub> = 5 V ± 0.5 V.

(2) All typical values are at V<sub>CC</sub> = 3.3 V or V<sub>CC</sub> = 5 V, and T<sub>A</sub> = 25°C.

## 6.6 Electrical Characteristics — Driver

over operating free-air temperature range (unless otherwise noted) (see [Figure 8](#)).<sup>(1)</sup>

| PARAMETER                      | TEST CONDITIONS              | MIN   | TYP <sup>(2)</sup> | MAX | UNIT  |     |    |
|--------------------------------|------------------------------|---|--------------------|-----|-------|-----|----|
| V <sub>OH</sub>                | High-level output voltage    | DOUT at R <sub>L</sub> = 3 kΩ to GND, DIN = GND             |                    | 5   | 5.4   | V   |    |
| V <sub>OL</sub>                | Low-level output voltage     | DOUT at R <sub>L</sub> = 3 kΩ to GND, DIN = V <sub>CC</sub> |                    | –5  | –5.4  | V   |    |
| I <sub>IH</sub>                | High-level input current     | V <sub>I</sub> = V <sub>CC</sub>                            |                    |     | ±0.01 | ±1  | μA |
| I <sub>IL</sub>                | Low-level input current      | V <sub>I</sub> at GND                                       |                    |     | ±0.01 | ±1  | μA |
| I <sub>OS</sub> <sup>(3)</sup> | Short-circuit output current | V <sub>CC</sub> = 3.6 V, V <sub>O</sub> = 0 V               |                    |     | ±35   | ±60 | mA |
|                                |                              | V <sub>CC</sub> = 5.5 V, V <sub>O</sub> = 0 V               |                    |     |       |     |    |
| r <sub>O</sub>                 | Output resistance            | V <sub>CC</sub> , V+, and V– = 0 V, V <sub>O</sub> = ±2 V   |                    | 300 | 10M   |     | Ω  |

(1) Test conditions are C1–C4 = 0.1 μF at V<sub>CC</sub> = 3.3 V ± 0.3 V; C1 = 0.047 μF, C2–C4 = 0.33 μF at V<sub>CC</sub> = 5 V ± 0.5 V.

(2) Short-circuit durations should be controlled to prevent exceeding the device absolute power dissipation ratings, and not more than one output should be shorted at a time.

(3) All typical values are at V<sub>CC</sub> = 3.3 V or V<sub>CC</sub> = 5 V, and T<sub>A</sub> = 25°C.

## 6.7 Electrical Characteristics — Receiver

over recommended ranges of supply voltage and operating free-air temperature (unless otherwise noted) (see [Figure 8](#)).<sup>(1)</sup>

| PARAMETER        | TEST CONDITIONS   | MIN                            | TYP <sup>(2)</sup> | MAX                   | UNIT                  |     |    |
|------------------|---|--------------------------------|--------------------|-----------------------|-----------------------|-----|----|
| V <sub>OH</sub>  | High-level output voltage                               | I <sub>OH</sub> = –1 mA        |                    | V <sub>CC</sub> – 0.6 | V <sub>CC</sub> – 0.1 | V   |    |
| V <sub>OL</sub>  | Low-level output voltage                                | I <sub>OL</sub> = 1.6 mA       |                    |                       | 0.4                   | V   |    |
| V <sub>IT+</sub> | Positive-going input threshold voltage                  | V <sub>CC</sub> = 3.3 V        |                    |                       | 1.5                   | 2.4 | V  |
|                  |   | V <sub>CC</sub> = 5 V          |                    |                       | 1.8                   | 2.4 |    |
| V <sub>IT–</sub> | Negative-going input threshold voltage                  | V <sub>CC</sub> = 3.3 V        |                    | 0.6                   | 1.2                   |     | V  |
|                  |   | V <sub>CC</sub> = 5 V          |                    | 0.8                   | 1.5                   |     |    |
| V <sub>hys</sub> | Input hysteresis (V <sub>IT+</sub> – V <sub>IT–</sub> ) |                                |                    |                       | 0.3                   |     | V  |
| r <sub>i</sub>   | Input resistance  | V <sub>I</sub> = ±3 V to ±25 V |                    | 3                     | 5                     | 7   | kΩ |

(1) Test conditions are C1–C4 = 0.1 μF at V<sub>CC</sub> = 3.3 V ± 0.3 V; C1 = 0.047 μF, C2–C4 = 0.33 μF at V<sub>CC</sub> = 5 V ± 0.5 V.

(2) All typical values are at V<sub>CC</sub> = 3.3 V or V<sub>CC</sub> = 5 V, and T<sub>A</sub> = 25°C.

### 6.8 Switching Characteristics

over recommended ranges of supply voltage and operating free-air temperature (unless otherwise noted) (see Figure 8)<sup>(1)</sup>

| PARAMETER   | TEST CONDITIONS   | MIN                                | TYP <sup>(2)</sup> | MAX | UNIT |
|---|---|------------------------------------|--------------------|-----|------|
| Maximum data rate   | R <sub>L</sub> = 3 kΩ, One DOUT switching, C <sub>L</sub> = 1000 pF, see Figure 4 | 150                                | 250                |     | kbps |
| t <sub>sk(p)</sub> Driver pulse skew <sup>(3)</sup>                         | R <sub>L</sub> = 3 kΩ to 7 kΩ, see Figure 5, C <sub>L</sub> = 150 pF to 2500 pF,  |                                    | 300                |     | ns   |
| SR(tr) Driver slew rate, transition region (see Figure 4)                   | R <sub>L</sub> = 3 kΩ to 7 kΩ, V <sub>CC</sub> = 3.3 V                            | C <sub>L</sub> = 150 pF to 1000 pF |                    | 6   | 30   |
|   |   | C <sub>L</sub> = 150 pF to 2500 pF |                    | 4   | 30   |
| t <sub>PLH</sub> Receiver propagation delay time, low- to high-level output | C <sub>L</sub> = 150 pF, see Figure 6   |                                    |                    | 300 | ns   |
| t <sub>PHL</sub> Receiver propagation delay time, high- to low-level output |   |                                    |                    | 300 | ns   |
| t <sub>sk(p)</sub> Receiver pulse skew <sup>(3)</sup>                       |   |                                    |                    | 300 | ns   |

(1) Test conditions are C1–C4 = 0.1 μF at V<sub>CC</sub> = 3.3 V ± 0.3 V; C1 = 0.047 μF, C2–C4 = 0.33 μF at V<sub>CC</sub> = 5 V ± 0.5 V.

(2) All typical values are at V<sub>CC</sub> = 3.3 V or V<sub>CC</sub> = 5 V, and T<sub>A</sub> = 25°C.

(3) Pulse skew is defined as |t<sub>PLH</sub> – t<sub>PHL</sub>| of each channel of the same device.

### 6.9 Typical Characteristics

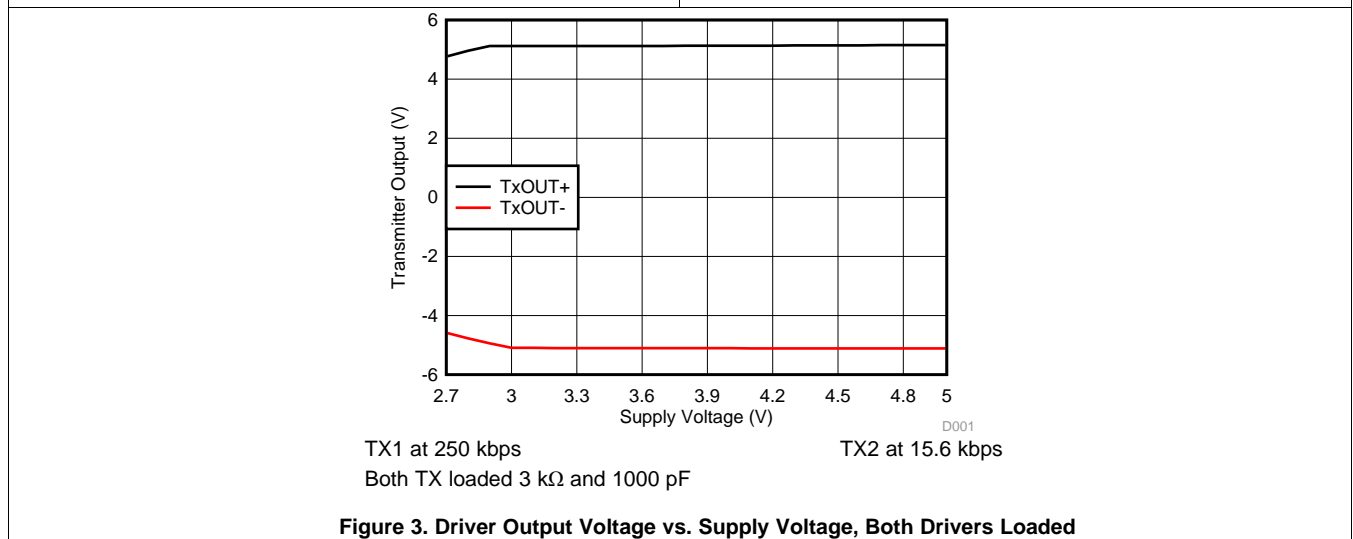
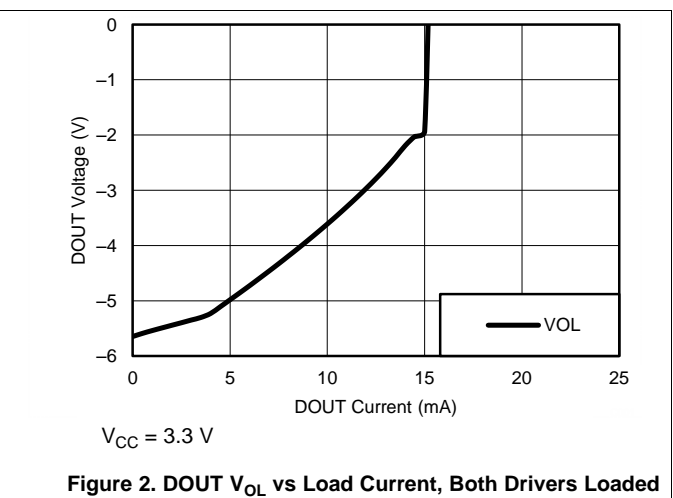
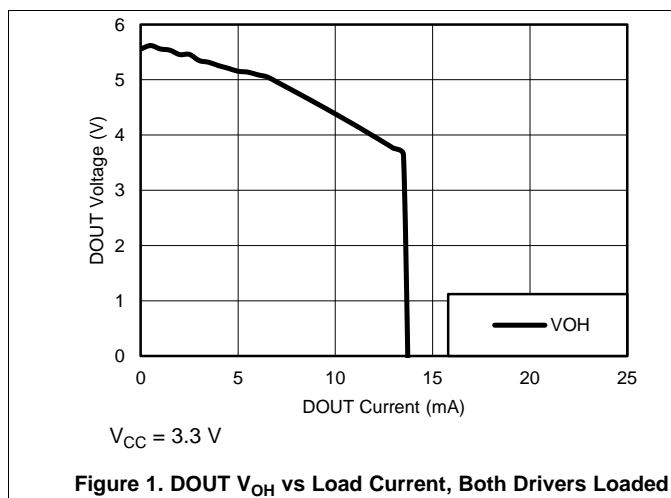

## 7 Parameter Measurement Information

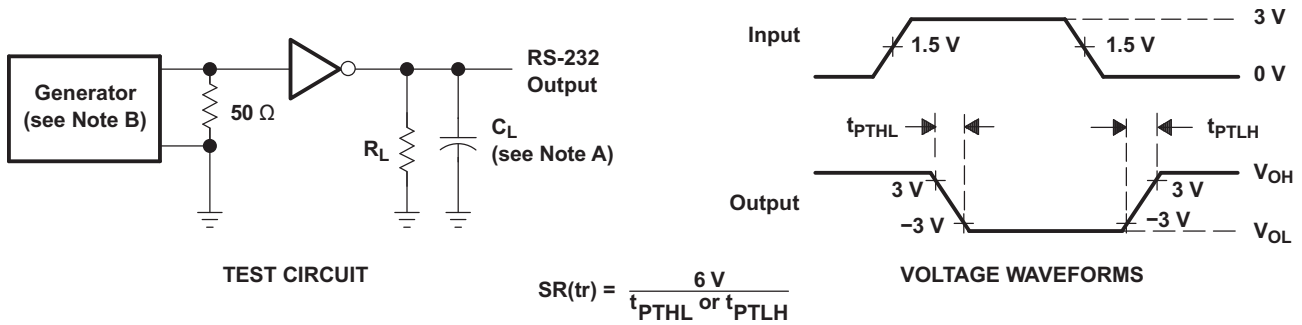

A.  $C_L$  includes probe and jig capacitance

B. The pulse generator has the following characteristics: PRR = 250 kbps,  $Z_O = 50\ \Omega$ , 50% duty cycle,  $t_r \leq 10\text{ ns}$ ,  $t_f \leq 10\text{ ns}$

Figure 4. Driver Slew Rate

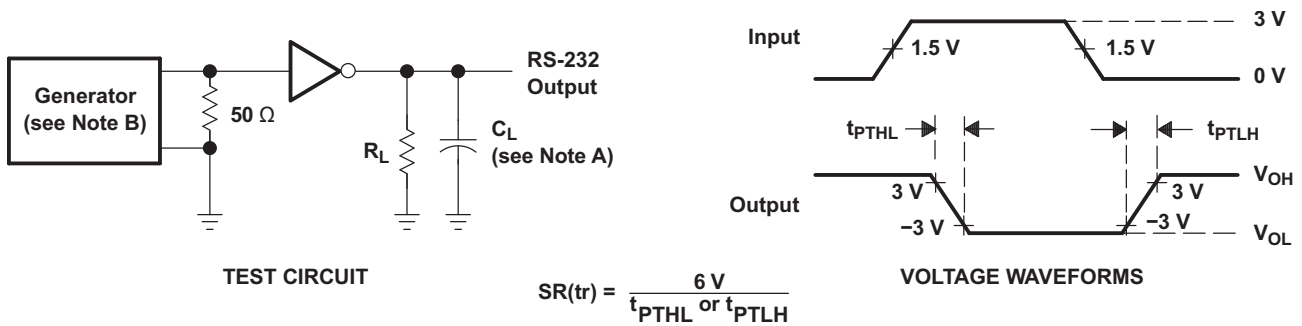

A.  $C_L$  includes probe and jig capacitance

B. The pulse generator has the following characteristics: PRR = 250 kbps,  $Z_O = 50\ \Omega$ , 50% duty cycle,  $t_r \leq 10\text{ ns}$ ,  $t_f \leq 10\text{ ns}$

Figure 5. Driver Pulse Skew

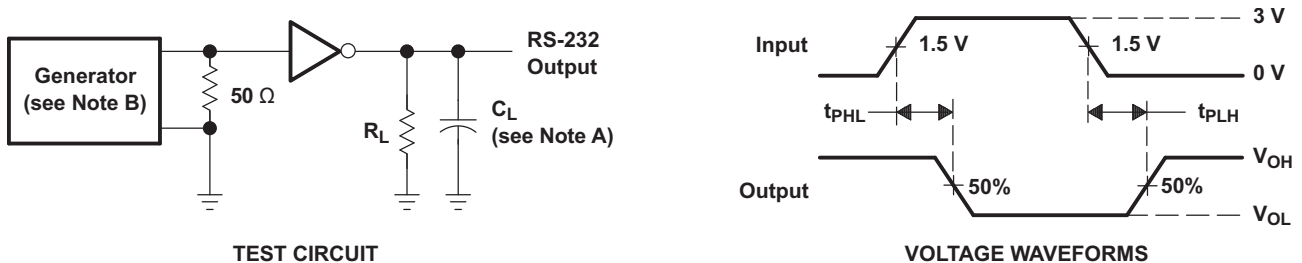

A.  $C_L$  includes probe and jig capacitance

B. The pulse generator has the following characteristics:  $Z_O = 50\ \Omega$ , 50% duty cycle,  $t_r \leq 10\text{ ns}$ ,  $t_f \leq 10\text{ ns}$

Figure 6. Receiver Propagation Delay Times

## 8 Detailed Description

### 8.1 Overview

The TRS3232E device consists of two line drivers, two-line receivers, and a dual charge-pump circuit with IEC61000-4-2 ESD protection terminal to terminal (serial-port connection terminals, including GND). The device meets the requirements of TIA/EIA-232-F and provides the electrical interface between an asynchronous communication controller and the serial-port connector. The charge pump and four small external capacitors allow operation from a single 3-V to 5.5-V supply. The device operates at data signaling rates up to 250 kbps and a maximum of 30-V/ $\mu$ s driver output slew rate. Outputs are protected against shorts to ground.

### 8.2 Functional Block Diagram

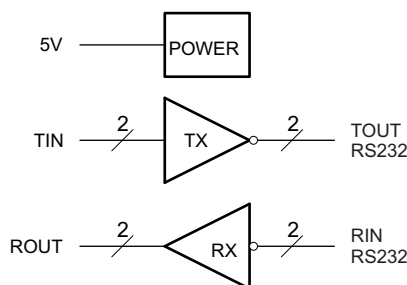

### 8.3 Feature Description

#### 8.3.1 Power

The power block increases, inverts, and regulates voltage at V+ and V– pins using a charge pump that requires four external capacitors.

#### 8.3.2 RS232 Driver

Two drivers interface standard logic level to RS232 levels. Both DIN inputs must be valid high or low.

#### 8.3.3 RS232 Receiver

Two receivers interface RS232 levels to standard logic levels. An open input will result in a high output on ROUT. Each RIN input includes an internal standard RS232 load.

## 8.4 Device Functional Modes

Table 1 and Table 2 list the functional modes of the drivers and receivers of TRS3232E.

**Table 1. Each Driver<sup>(1)</sup>**

| INPUT<br>DIN | OUTPUT<br>DOUT |
|--------------|----------------|
| L            | H              |
| H            | L              |

(1) H = high level, L = low level

**Table 2. Each Receiver<sup>(1)</sup>**

| INPUT<br>RIN | OUTPUT<br>ROUT |
|--------------|----------------|
| L            | H              |
| H            | L              |
| Open         | H              |

(1) H = high level, L = low level,  
Open = input disconnected or connected driver off

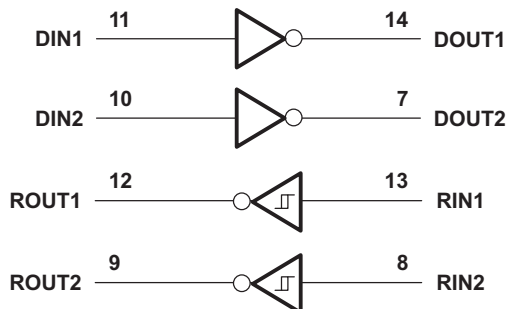

**Figure 7. Logic Diagram**

### 8.4.1 $V_{CC}$ Powered by 3 V to 5.5 V

The device is in normal operation.

### 8.4.2 $V_{CC}$ Unpowered, $V_{CC} = 0$ V

When TRS3232E is unpowered, it can be safely connected to an active remote RS232 device.

## 9 Application and Implementation

### NOTE

Information in the following applications sections is not part of the TI component specification, and TI does not warrant its accuracy or completeness. TI's customers are responsible for determining suitability of components for their purposes. Customers should validate and test their design implementation to confirm system functionality.

### 9.1 Application Information

The TRS3232E interfaces logic lines from a UART or microcontroller to the voltage and current levels needed for RS232 communication. The TIN inputs will accept 5-V logic with 3.3-V  $V_{CC}$  supply. All baud rates up to 250-kbps are supported.

It is important to use the correct capacitors for the  $V_{CC}$  voltage. This will reduce ripple voltage on the TOUT outputs. If only one driver is needed, the unused driver input should be connected to  $V_{CC}$  or ground.

### 9.2 Typical Application

ROUT and DIN connect to UART or general-purpose logic lines. RIN and DOUT lines connect to a RS232 connector or cable. For proper operation, add capacitors as shown in [Table 3](#).

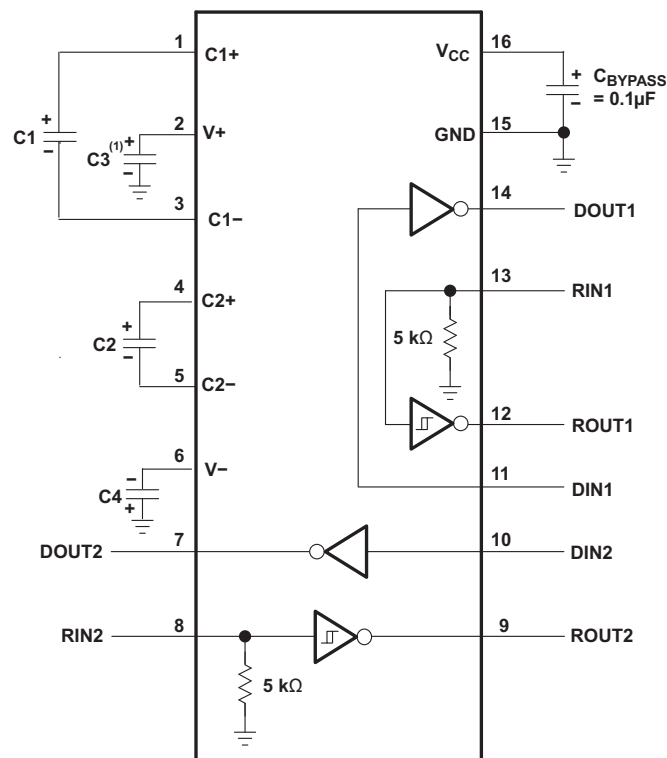

- (1) C3 can be connected to  $V_{CC}$  or GND

Resistor values shown are nominal.

Nonpolarized ceramic capacitors are acceptable. If polarized tantalum or electrolytic capacitors are used, they should be connected as shown.

**Figure 8. Typical Operating Circuit and Capacitor Values**

**Table 3. V<sub>CC</sub> vs Capacitor Values**

| V <sub>CC</sub> | C1       | C2, C3, C4 |
|-----------------|----------|------------|
| 3.3 V ± 0.3 V   | 0.1 μF   | 0.1 μF     |
| 5 V ± 0.5 V     | 0.047 μF | 0.33 μF    |
| 3 V ± 5.5 V     | 0.1 μF   | 0.47 μF    |

**9.2.1 Design Requirements**

The recommended V<sub>CC</sub> is 3.3 V or 5 V. 3 V to 5.5 V is also possible.

The maximum recommended bit rate is 250 kbps.

**9.2.2 Detailed Design Procedure**

All DIN inputs must be connected to valid low or high logic levels.

Select capacitor values based on V<sub>CC</sub> level for best performance.

**9.2.3 Application Curve**

Figure 9 curves are for 3.3-V VCC and 250-kbps alternative bit data stream.

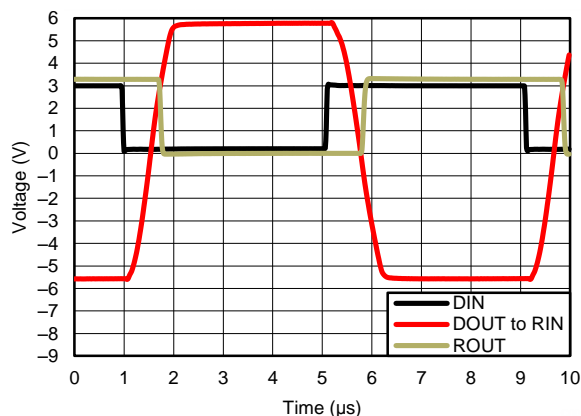

**Figure 9. 250 kbps Driver to Receiver Loopback Timing Waveform, V<sub>CC</sub>= 3.3 V**

## 10 Power Supply Recommendations

The supply voltage,  $V_{CC}$ , should be between 3 V and 5.5 V. Select the values of the charge-pump capacitors using [Table 3](#).

## 11 Layout

### 11.1 Layout Guidelines

Keep the external capacitor traces short, specifically on the C1 and C2 nodes that have the fastest rise and fall times.

### 11.2 Layout Example

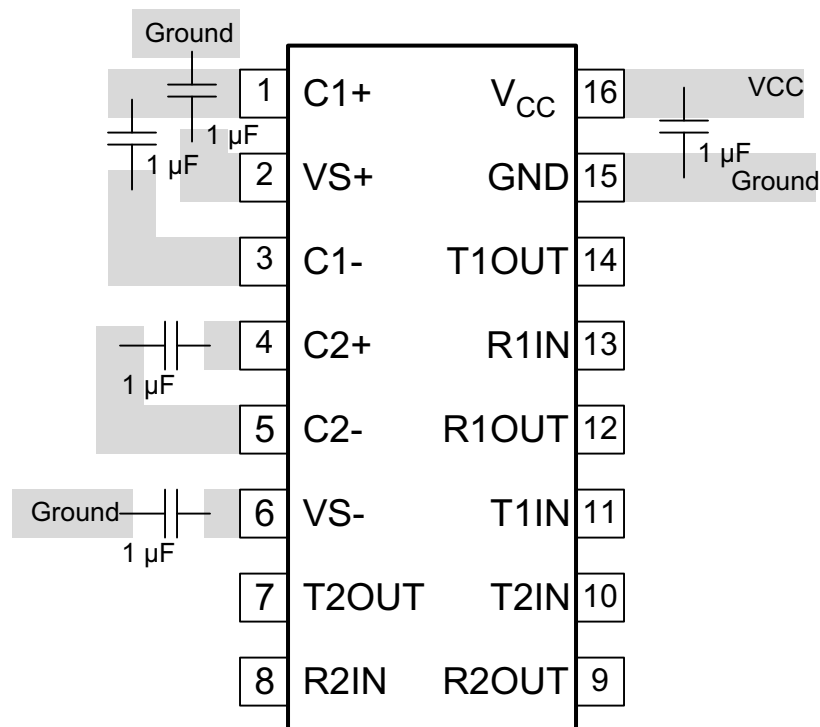

**Figure 10. Layout Diagram**

## 12 Device and Documentation Support

### 12.1 Community Resources

The following links connect to TI community resources. Linked contents are provided "AS IS" by the respective contributors. They do not constitute TI specifications and do not necessarily reflect TI's views; see TI's [Terms of Use](#).

**TI E2E™ Online Community** *TI's Engineer-to-Engineer (E2E) Community*. Created to foster collaboration among engineers. At [e2e.ti.com](http://e2e.ti.com), you can ask questions, share knowledge, explore ideas and help solve problems with fellow engineers.

**Design Support** *TI's Design Support* Quickly find helpful E2E forums along with design support tools and contact information for technical support.

### 12.2 Trademarks

E2E is a trademark of Texas Instruments.  
All other trademarks are the property of their respective owners.

### 12.3 Electrostatic Discharge Caution



These devices have limited built-in ESD protection. The leads should be shorted together or the device placed in conductive foam during storage or handling to prevent electrostatic damage to the MOS gates.

### 12.4 Glossary

[SLYZ022](#) — *TI Glossary*.

This glossary lists and explains terms, acronyms, and definitions.

## 13 Mechanical, Packaging, and Orderable Information

The following pages include mechanical, packaging, and orderable information. This information is the most current data available for the designated devices. This data is subject to change without notice and revision of this document. For browser based versions of this data sheet, refer to the left hand navigation.

**PACKAGING INFORMATION**

| Orderable Device | Status<br>(1) | Package Type | Package<br>Drawing | Pins | Package<br>Qty | Eco Plan<br>(2)            | Lead/Ball Finish<br>(6) | MSL Peak Temp<br>(3) | Op Temp (°C) | Device Marking<br>(4/5) | Samples                 |
|------------------|---------------|--------------|--------------------|------|----------------|----------------------------|-------------------------|----------------------|--------------|-------------------------|-------------------------|
| TRS3232ECD       | ACTIVE        | SOIC         | D                  | 16   | 40             | Green (RoHS<br>& no Sb/Br) | CU NIPDAU               | Level-1-260C-UNLIM   | 0 to 70      | TRS3232EC               | <a href="#">Samples</a> |
| TRS3232ECDBR     | ACTIVE        | SSOP         | DB                 | 16   | 2000           | Green (RoHS<br>& no Sb/Br) | CU NIPDAU               | Level-1-260C-UNLIM   | 0 to 70      | RS32EC                  | <a href="#">Samples</a> |
| TRS3232ECDR      | ACTIVE        | SOIC         | D                  | 16   | 2500           | Green (RoHS<br>& no Sb/Br) | CU NIPDAU               | Level-1-260C-UNLIM   | 0 to 70      | TRS3232EC               | <a href="#">Samples</a> |
| TRS3232ECDW      | ACTIVE        | SOIC         | DW                 | 16   | 40             | Green (RoHS<br>& no Sb/Br) | CU NIPDAU               | Level-1-260C-UNLIM   | 0 to 70      | TRS3232EC               | <a href="#">Samples</a> |
| TRS3232ECDWR     | ACTIVE        | SOIC         | DW                 | 16   | 2000           | Green (RoHS<br>& no Sb/Br) | CU NIPDAU               | Level-1-260C-UNLIM   | 0 to 70      | TRS3232EC               | <a href="#">Samples</a> |
| TRS3232ECPW      | ACTIVE        | TSSOP        | PW                 | 16   | 90             | Green (RoHS<br>& no Sb/Br) | CU NIPDAU               | Level-1-260C-UNLIM   | 0 to 70      | RS32EC                  | <a href="#">Samples</a> |
| TRS3232ECPWR     | ACTIVE        | TSSOP        | PW                 | 16   | 2000           | Green (RoHS<br>& no Sb/Br) | CU NIPDAU               | Level-1-260C-UNLIM   | 0 to 70      | RS32EC                  | <a href="#">Samples</a> |
| TRS3232EID       | ACTIVE        | SOIC         | D                  | 16   | 40             | Green (RoHS<br>& no Sb/Br) | CU NIPDAU               | Level-1-260C-UNLIM   | -40 to 85    | TRS3232EI               | <a href="#">Samples</a> |
| TRS3232EIDB      | ACTIVE        | SSOP         | DB                 | 16   | 80             | Green (RoHS<br>& no Sb/Br) | CU NIPDAU               | Level-1-260C-UNLIM   | -40 to 85    | RS32EI                  | <a href="#">Samples</a> |
| TRS3232EIDBR     | ACTIVE        | SSOP         | DB                 | 16   | 2000           | Green (RoHS<br>& no Sb/Br) | CU NIPDAU               | Level-1-260C-UNLIM   | -40 to 85    | RS32EI                  | <a href="#">Samples</a> |
| TRS3232EIDR      | ACTIVE        | SOIC         | D                  | 16   | 2500           | Green (RoHS<br>& no Sb/Br) | CU NIPDAU               | Level-1-260C-UNLIM   | -40 to 85    | TRS3232EI               | <a href="#">Samples</a> |
| TRS3232EIDW      | ACTIVE        | SOIC         | DW                 | 16   | 40             | Green (RoHS<br>& no Sb/Br) | CU NIPDAU               | Level-1-260C-UNLIM   | -40 to 85    | TRS3232EI               | <a href="#">Samples</a> |
| TRS3232EIDWR     | ACTIVE        | SOIC         | DW                 | 16   | 2000           | Green (RoHS<br>& no Sb/Br) | CU NIPDAU               | Level-1-260C-UNLIM   | -40 to 85    | TRS3232EI               | <a href="#">Samples</a> |
| TRS3232EIPW      | ACTIVE        | TSSOP        | PW                 | 16   | 90             | Green (RoHS<br>& no Sb/Br) | CU NIPDAU               | Level-1-260C-UNLIM   | -40 to 85    | RS32EI                  | <a href="#">Samples</a> |
| TRS3232EIPWG4    | ACTIVE        | TSSOP        | PW                 | 16   | 90             | Green (RoHS<br>& no Sb/Br) | CU NIPDAU               | Level-1-260C-UNLIM   | -40 to 85    | RS32EI                  | <a href="#">Samples</a> |
| TRS3232EIPWR     | ACTIVE        | TSSOP        | PW                 | 16   | 2000           | Green (RoHS<br>& no Sb/Br) | CU NIPDAU               | Level-1-260C-UNLIM   | -40 to 85    | RS32EI                  | <a href="#">Samples</a> |
| TRS3232EIPWRG4   | ACTIVE        | TSSOP        | PW                 | 16   | 2000           | Green (RoHS<br>& no Sb/Br) | CU NIPDAU               | Level-1-260C-UNLIM   | -40 to 85    | RS32EI                  | <a href="#">Samples</a> |

(1) The marketing status values are defined as follows:

**ACTIVE:** Product device recommended for new designs.

**LIFEBUY:** TI has announced that the device will be discontinued, and a lifetime-buy period is in effect.

**NRND:** Not recommended for new designs. Device is in production to support existing customers, but TI does not recommend using this part in a new design.

**PREVIEW:** Device has been announced but is not in production. Samples may or may not be available.

**OBSOLETE:** TI has discontinued the production of the device.

(2) **RoHS:** TI defines "RoHS" to mean semiconductor products that are compliant with the current EU RoHS requirements for all 10 RoHS substances, including the requirement that RoHS substance do not exceed 0.1% by weight in homogeneous materials. Where designed to be soldered at high temperatures, "RoHS" products are suitable for use in specified lead-free processes. TI may reference these types of products as "Pb-Free".

**RoHS Exempt:** TI defines "RoHS Exempt" to mean products that contain lead but are compliant with EU RoHS pursuant to a specific EU RoHS exemption.

**Green:** TI defines "Green" to mean the content of Chlorine (Cl) and Bromine (Br) based flame retardants meet JS709B low halogen requirements of  $\leq 1000$ ppm threshold. Antimony trioxide based flame retardants must also meet the  $\leq 1000$ ppm threshold requirement.

(3) MSL, Peak Temp. - The Moisture Sensitivity Level rating according to the JEDEC industry standard classifications, and peak solder temperature.

(4) There may be additional marking, which relates to the logo, the lot trace code information, or the environmental category on the device.

(5) Multiple Device Markings will be inside parentheses. Only one Device Marking contained in parentheses and separated by a "~" will appear on a device. If a line is indented then it is a continuation of the previous line and the two combined represent the entire Device Marking for that device.

(6) Lead/Ball Finish - Orderable Devices may have multiple material finish options. Finish options are separated by a vertical ruled line. Lead/Ball Finish values may wrap to two lines if the finish value exceeds the maximum column width.

**Important Information and Disclaimer:** The information provided on this page represents TI's knowledge and belief as of the date that it is provided. TI bases its knowledge and belief on information provided by third parties, and makes no representation or warranty as to the accuracy of such information. Efforts are underway to better integrate information from third parties. TI has taken and continues to take reasonable steps to provide representative and accurate information but may not have conducted destructive testing or chemical analysis on incoming materials and chemicals. TI and TI suppliers consider certain information to be proprietary, and thus CAS numbers and other limited information may not be available for release.

In no event shall TI's liability arising out of such information exceed the total purchase price of the TI part(s) at issue in this document sold by TI to Customer on an annual basis.

#### **OTHER QUALIFIED VERSIONS OF TRS3232E :**

- Automotive: [TRS3232E-Q1](#)

NOTE: Qualified Version Definitions:

- Automotive - Q100 devices qualified for high-reliability automotive applications targeting zero defects

## TAPE AND REEL INFORMATION



### QUADRANT ASSIGNMENTS FOR PIN 1 ORIENTATION IN TAPE



\*All dimensions are nominal

| Device       | Package Type | Package Drawing | Pins | SPQ  | Reel Diameter (mm) | Reel Width W1 (mm) | A0 (mm) | B0 (mm) | K0 (mm) | P1 (mm) | W (mm) | Pin1 Quadrant |
|--------------|--------------|-----------------|------|------|--------------------|--------------------|---------|---------|---------|---------|--------|---------------|
| TRS3232ECDR  | SOIC         | D               | 16   | 2500 | 330.0              | 16.4               | 6.5     | 10.3    | 2.1     | 8.0     | 16.0   | Q1            |
| TRS3232ECDWR | SOIC         | DW              | 16   | 2000 | 330.0              | 16.4               | 10.75   | 10.7    | 2.7     | 12.0    | 16.0   | Q1            |
| TRS3232ECPWR | TSSOP        | PW              | 16   | 2000 | 330.0              | 12.4               | 6.9     | 5.6     | 1.6     | 8.0     | 12.0   | Q1            |
| TRS3232EIDR  | SOIC         | D               | 16   | 2500 | 330.0              | 16.4               | 6.5     | 10.3    | 2.1     | 8.0     | 16.0   | Q1            |
| TRS3232EIDWR | SOIC         | DW              | 16   | 2000 | 330.0              | 16.4               | 10.75   | 10.7    | 2.7     | 12.0    | 16.0   | Q1            |
| TRS3232EIPWR | TSSOP        | PW              | 16   | 2000 | 330.0              | 12.4               | 6.9     | 5.6     | 1.6     | 8.0     | 12.0   | Q1            |

**TAPE AND REEL BOX DIMENSIONS**

\*All dimensions are nominal

| Device       | Package Type | Package Drawing | Pins | SPQ  | Length (mm) | Width (mm) | Height (mm) |
|--------------|--------------|-----------------|------|------|-------------|------------|-------------|
| TRS3232ECDR  | SOIC         | D               | 16   | 2500 | 367.0       | 367.0      | 38.0        |
| TRS3232ECDWR | SOIC         | DW              | 16   | 2000 | 350.0       | 350.0      | 43.0        |
| TRS3232ECPWR | TSSOP        | PW              | 16   | 2000 | 367.0       | 367.0      | 35.0        |
| TRS3232EIDR  | SOIC         | D               | 16   | 2500 | 367.0       | 367.0      | 38.0        |
| TRS3232EIDWR | SOIC         | DW              | 16   | 2000 | 350.0       | 350.0      | 43.0        |
| TRS3232EIPWR | TSSOP        | PW              | 16   | 2000 | 367.0       | 367.0      | 35.0        |

## GENERIC PACKAGE VIEW

**DW 16**

**SOIC - 2.65 mm max height**

7.5 x 10.3, 1.27 mm pitch

SMALL OUTLINE INTEGRATED CIRCUIT

This image is a representation of the package family, actual package may vary.  
Refer to the product data sheet for package details.

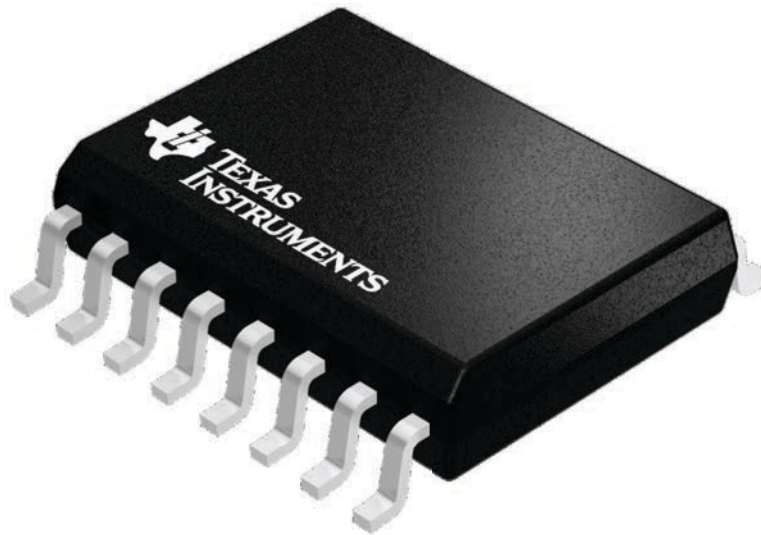

4224780/A



# DW0016A

# PACKAGE OUTLINE SOIC - 2.65 mm max height

SOIC

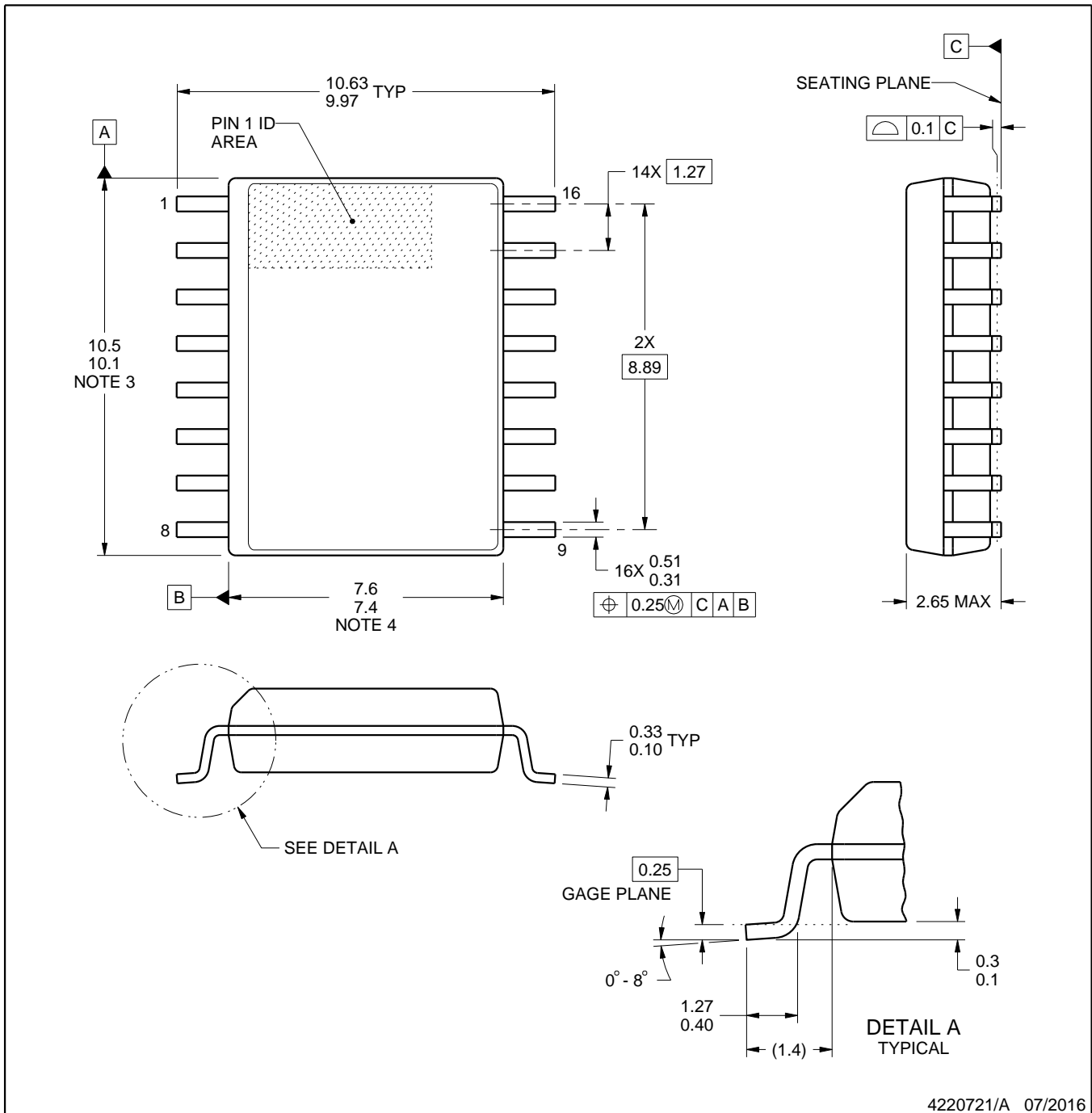

4220721/A 07/2016

### NOTES:

1. All linear dimensions are in millimeters. Dimensions in parenthesis are for reference only. Dimensioning and tolerancing per ASME Y14.5M.
2. This drawing is subject to change without notice.
3. This dimension does not include mold flash, protrusions, or gate burrs. Mold flash, protrusions, or gate burrs shall not exceed 0.15 mm, per side.
4. This dimension does not include interlead flash. Interlead flash shall not exceed 0.25 mm, per side.
5. Reference JEDEC registration MS-013.

# EXAMPLE BOARD LAYOUT

DW0016A

SOIC - 2.65 mm max height

SOIC

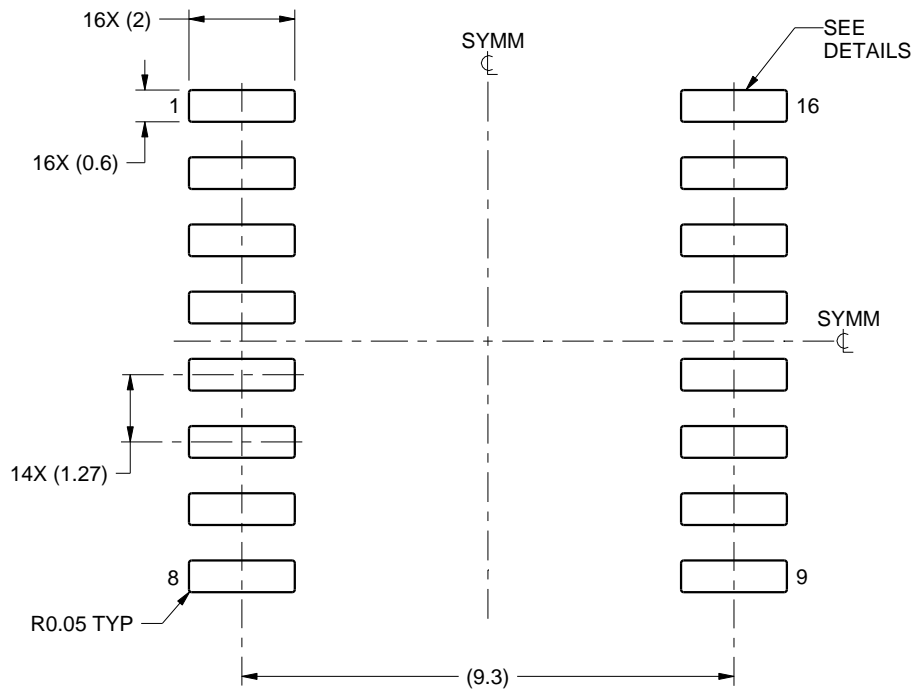

LAND PATTERN EXAMPLE  
SCALE:7X



SOLDER MASK DETAILS

4220721/A 07/2016

NOTES: (continued)

6. Publication IPC-7351 may have alternate designs.

7. Solder mask tolerances between and around signal pads can vary based on board fabrication site.

# EXAMPLE STENCIL DESIGN

DW0016A

SOIC - 2.65 mm max height

SOIC

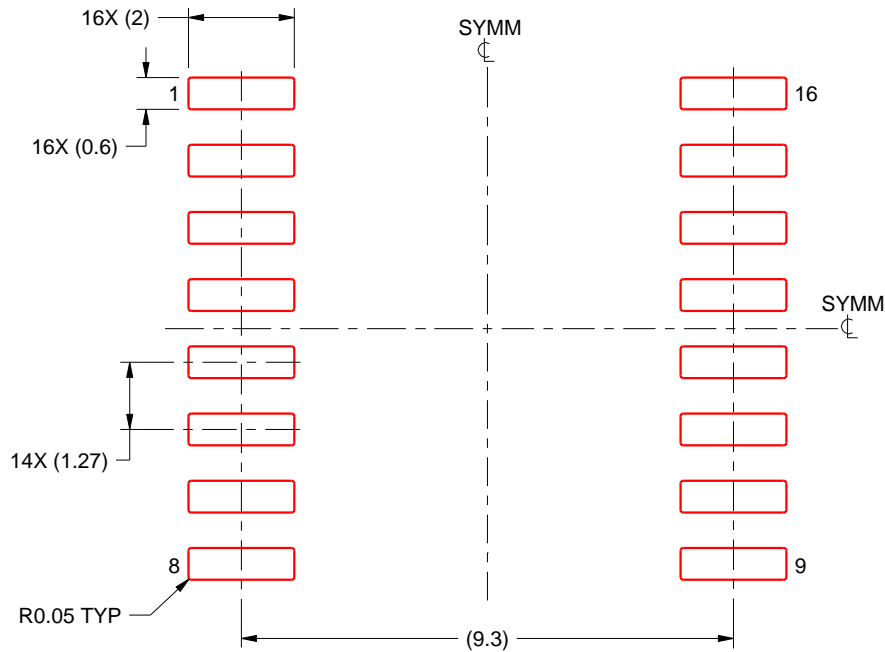

SOLDER PASTE EXAMPLE  
BASED ON 0.125 mm THICK STENCIL  
SCALE:7X

4220721/A 07/2016

NOTES: (continued)

8. Laser cutting apertures with trapezoidal walls and rounded corners may offer better paste release. IPC-7525 may have alternate design recommendations.
9. Board assembly site may have different recommendations for stencil design.



D (R-PDSO-G16)

PLASTIC SMALL OUTLINE



- NOTES:
- A. All linear dimensions are in inches (millimeters).
  - B. This drawing is subject to change without notice.
  - C. Body length does not include mold flash, protrusions, or gate burrs. Mold flash, protrusions, or gate burrs shall not exceed 0.006 (0,15) each side.
  - D. Body width does not include interlead flash. Interlead flash shall not exceed 0.017 (0,43) each side.
  - E. Reference JEDEC MS-012 variation AC.



4220204/A 02/2017

NOTES:

1. All linear dimensions are in millimeters. Any dimensions in parenthesis are for reference only. Dimensioning and tolerancing per ASME Y14.5M.
2. This drawing is subject to change without notice.
3. This dimension does not include mold flash, protrusions, or gate burrs. Mold flash, protrusions, or gate burrs shall not exceed 0.15 mm per side.
4. This dimension does not include interlead flash. Interlead flash shall not exceed 0.25 mm per side.
5. Reference JEDEC registration MO-153.

# EXAMPLE BOARD LAYOUT

PW0016A

TSSOP - 1.2 mm max height

SMALL OUTLINE PACKAGE



LAND PATTERN EXAMPLE  
EXPOSED METAL SHOWN  
SCALE: 10X



SOLDER MASK DETAILS

4220204/A 02/2017

NOTES: (continued)

- 6. Publication IPC-7351 may have alternate designs.
- 7. Solder mask tolerances between and around signal pads can vary based on board fabrication site.

# EXAMPLE STENCIL DESIGN

PW0016A

TSSOP - 1.2 mm max height

SMALL OUTLINE PACKAGE

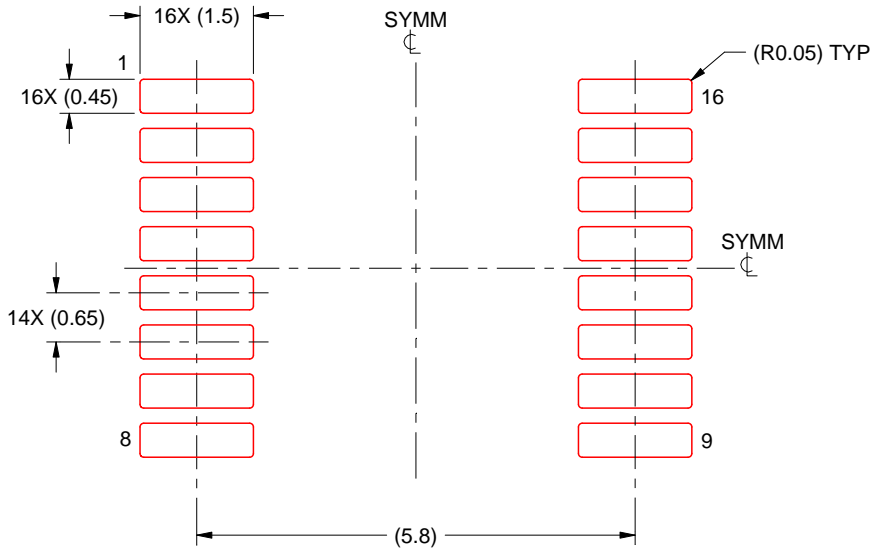

SOLDER PASTE EXAMPLE  
BASED ON 0.125 mm THICK STENCIL  
SCALE: 10X

4220204/A 02/2017

NOTES: (continued)

8. Laser cutting apertures with trapezoidal walls and rounded corners may offer better paste release. IPC-7525 may have alternate design recommendations.
9. Board assembly site may have different recommendations for stencil design.

## IMPORTANT NOTICE AND DISCLAIMER

TI PROVIDES TECHNICAL AND RELIABILITY DATA (INCLUDING DATASHEETS), DESIGN RESOURCES (INCLUDING REFERENCE DESIGNS), APPLICATION OR OTHER DESIGN ADVICE, WEB TOOLS, SAFETY INFORMATION, AND OTHER RESOURCES "AS IS" AND WITH ALL FAULTS, AND DISCLAIMS ALL WARRANTIES, EXPRESS AND IMPLIED, INCLUDING WITHOUT LIMITATION ANY IMPLIED WARRANTIES OF MERCHANTABILITY, FITNESS FOR A PARTICULAR PURPOSE OR NON-INFRINGEMENT OF THIRD PARTY INTELLECTUAL PROPERTY RIGHTS.

These resources are intended for skilled developers designing with TI products. You are solely responsible for (1) selecting the appropriate TI products for your application, (2) designing, validating and testing your application, and (3) ensuring your application meets applicable standards, and any other safety, security, or other requirements. These resources are subject to change without notice. TI grants you permission to use these resources only for development of an application that uses the TI products described in the resource. Other reproduction and display of these resources is prohibited. No license is granted to any other TI intellectual property right or to any third party intellectual property right. TI disclaims responsibility for, and you will fully indemnify TI and its representatives against, any claims, damages, costs, losses, and liabilities arising out of your use of these resources.

TI's products are provided subject to TI's Terms of Sale ([www.ti.com/legal/termsofsale.html](http://www.ti.com/legal/termsofsale.html)) or other applicable terms available either on [ti.com](http://ti.com) or provided in conjunction with such TI products. TI's provision of these resources does not expand or otherwise alter TI's applicable warranties or warranty disclaimers for TI products.

Mailing Address: Texas Instruments, Post Office Box 655303, Dallas, Texas 75265  
Copyright © 2019, Texas Instruments Incorporated

## Looking for pricing, stock, or lifecycle information?

Click below to explore more details on WIN SOURCE:

 [View TRS3232EIDR on WIN SOURCE](#)

 [Texas Instruments](#) Information

## Optimize Your Supply Chain with WIN SOURCE Solutions

-  Global Sourcing Solution
-  Obsolete Management
-  Cost Control Management
-  Shortage Management
-  Alternative Solution
-  Excess Inventory Management