

FEATURES

- 5 V Stereo Audio DAC System
- Accepts 16-Bit/20-Bit/24-Bit Data
- Supports 24 Bits, 192 kHz Sample Rate
- Accepts a Wide Range of Sample Rates Including:
 - 32 kHz, 44.1 kHz, 48 kHz, 88.2 kHz, 96 kHz, and 192 kHz
- Multibit Sigma-Delta Modulator with Data Directed Scrambling
- Single-Ended Output for Easy Application
- 94 dB THD + N
- 108 dB SNR and Dynamic Range
- 75 dB Stopband Attenuation
- Clickless Volume Control
- Hardware and Software Controllable Clickless Mute
- Serial (SPI) Control for: Serial Mode, Number of Bits, Sample Rate, Volume, Mute, De-Emphasis and Output Phase
- Digital De-Emphasis Processing for 32 kHz, 44.1 kHz, and 48 kHz Sample Rates
- Programmable Dual Fractional-N PLL Clock Generator
- 27 MHz Master Clock Input/Oscillator
- Generated System Clocks
 - SCLK0: 33.8688 MHz
 - SCLK1: $384/256 f_s$ (32 kHz/44.1 kHz/48 kHz/88.2 kHz/96 kHz)
 - SCLK2: $512 f_s$ (32 kHz/44.1 kHz/48 kHz/88.2 kHz/96 kHz)/22.5792 MHz
- Better than 100 ps RMS Clock Jitter
- Flexible Serial Data Port with Right-Justified, Left-Justified, I²S-Compatible, and DSP Serial Port Modes
- 28-Lead SSOP Plastic Package

APPLICATIONS

DVD, CD, Home Theater Systems, Automotive Audio Systems, Sampling Musical Keyboards, Digital Mixing Consoles, Digital Audio Effects Processors

PRODUCT OVERVIEW

The AD1959 is a complete high-performance single-chip stereo digital audio playback system. It is comprised of a multibit sigma-delta modulator, digital interpolation filters, and analog output drive circuitry with an on-board dual PLL clock generator. Other features include an on-chip stereo attenuator and mute, programmed through an SPI-compatible serial control port. The AD1959 is fully compatible with all known DVD formats including 96 kHz and 192 kHz sample frequencies and 24 bits. It also is backwards-compatible by supporting 50 μ s/15 μ s digital de-emphasis for "redbook" compact discs, as well as de-emphasis at 32 kHz and 48 kHz sample rates.

The AD1959 has a simple but flexible serial data input port that allows for glueless interconnection to a variety of ADCs, DSP chips, AES/EBU receivers, and sample rate converters. The AD1959 can be configured in left-justified, I²S, right-justified, or DSP serial-port-compatible modes. It can support 16, 20, and 24 bits in all modes. The AD1959 accepts serial audio data in MSB first, two's-complement format, and operates from a single 5 V power supply. It is fabricated on a single monolithic integrated circuit and housed in a 28-lead SSOP package for operation over the temperature range -40°C to +105°C.

FUNCTIONAL BLOCK DIAGRAM

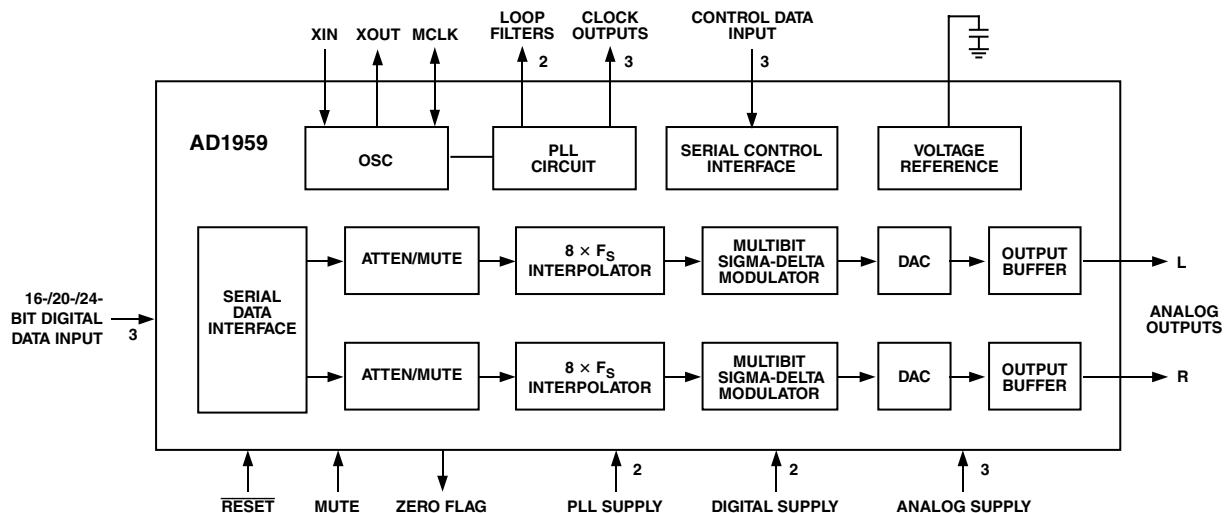

REV. 0

Information furnished by Analog Devices is believed to be accurate and reliable. However, no responsibility is assumed by Analog Devices for its use, nor for any infringements of patents or other rights of third parties that may result from its use. No license is granted by implication or otherwise under any patent or patent rights of Analog Devices.

One Technology Way, P.O. Box 9106, Norwood, MA 02062-9106, U.S.A.
 Tel: 781/329-4700
 Fax: 781/326-8703
www.analog.com
 © Analog Devices, Inc., 2001

AD1959—SPECIFICATIONS

TEST CONDITIONS UNLESS OTHERWISE NOTED

Supply Voltages (AVDD, DVDD)	5.0 V
Ambient Temperature	25°C
Input Clock	12.288 MHz
Input Signal	996.11 Hz
	-0.5 dB Full Scale
Input Sample Rate	48 kHz
Measurement Bandwidth	20 Hz to 20 kHz
Word Width	20 Bits
Load Capacitance	100 pF
Load Impedance	47 kΩ
Input Voltage HI	3.5 V
Input Voltage LO	0.8 V

ANALOG PERFORMANCE

	Min	Typ	Max	Unit
Resolution		24		Bits
Signal-to-Noise Ratio (20 Hz to 20 kHz)				
No Filter (Stereo)		105		dB
With A-Weighted Filter (Stereo)		108		dB
Dynamic Range (20 Hz to 20 kHz, -60 dB Input)				
No Filter (Stereo)		105		dB
With A-Weighted Filter (Stereo)	101	108		dB
Total Harmonic Distortion + Noise (Stereo)		-94	-91	dB
PLL Performance				
Master Clock Input Frequency		27		MHz
Generated System Clocks				
SCLK0		33.8688		MHz
SCLK1		12.288		MHz
SCLK2		22.5792		MHz
Jitter (SCLK0 and SCLK1)		85	125	ps rms
Analog Outputs				
Single-Ended Output Range (±Full Scale)		3.17		V p-p
Output Capacitance at Each Output Pin			2	pF
V _{REF} (FILTR)	2.34	2.39	2.44	V
Gain Error	-5	±2.0	+5	%
Interchannel Gain Mismatch	-0.15	±0.015	+0.15	dB
Gain Drift		150	250	ppm/°C
DC Offset	-25	-5	+15	mV
Out-of-Band Energy (0.5 × f _s to 100 kHz)			-90	dB
Interchannel Crosstalk (EIAJ Method)		-120		dB
Interchannel Phase Deviation		±0.1		Degrees
De-Emphasis Gain Error			±0.1	dB

NOTES

Performance of right and left channels is identical (exclusive of the Interchannel Gain Mismatch and Interchannel Phase Deviation specifications). Specifications subject to change without notice.

DIGITAL I/O (-40°C to +105°C)

	Min	Typ	Max	Unit
Input Voltage HI (V _{IH}) Except XIN	2.2			V
Input Voltage HI (V _{IH}) XIN	2.7			V
Input Voltage LO (V _{IL})			0.8	V
Input Leakage (I _{IH} @ V _{IH} = 2.4 V)			10	μA
Input Leakage (I _{IL} @ V _{IL} = 0.8 V)			10	μA
High Level Output Voltage (V _{OH}) I _{OH} = 1 mA	2.0			V
Low Level Output Voltage (V _{OL}) I _{OL} = 1 mA Except XOUT			0.4	V
Low Level Output Voltage (V _{OL}) I _{OL} = 1 mA XOUT			1.2	V
Input Capacitance			20	pF

Specifications subject to change without notice.

TEMPERATURE RANGE

	Min	Typ	Max	Unit
Specifications Guaranteed		25		°C
Functionality Guaranteed	-40		+105*	°C
Storage	-55		+150	°C

NOTES

*105°C ambient guaranteed for a 4-layer board, two 1 oz. planes, two 2 oz. signal layers. Derate to 85°C for 2-layer board, 2 oz. layers.

Specifications subject to change without notice.

POWER

	Min	Typ	Max	Unit
Supplies				
Voltage, Analog Digital PLL	4.50	5	5.50	V
Analog Current		36	42	mA
Digital Current		28	34	mA
PLL Current		27	32	mA
Dissipation				
Operation – All Supplies		455	540	mW
Operation – Analog Supply		180		mW
Operation – Digital Supply		140		mW
Operation – PLL Supply		135		mW

Specifications subject to change without notice.

DIGITAL FILTER CHARACTERISTICS

Sample Rate (kHz)	Pass Band (kHz)	Stop Band (kHz)	Stopband Attenuation (dB)	Pass-Band Ripple (dB)
44.1	DC–20	24.1–328.7	75	±0.0002
48	DC–21.8	26.23–358.28	75	±0.0002
96	DC–39.95	56.9–327.65	75	±0.0005
192	DC–87.2	117–327.65	60	0/–0.04 (DC–21.8 kHz) 0/–0.5 (DC–65.4 kHz) 0/–1.5 (DC–87.2 kHz)

Specifications subject to change without notice.

GROUP DELAY

Chip Mode	Group Delay Calculation	f_s	Group Delay	Unit
INT8× Mode	$24.625/f_s$	48 kHz	513	μs
INT4× Mode	$15.75/f_s$	96 kHz	164	μs
INT2× Mode	$14/f_s$	192 kHz	72.91	μs

Specifications subject to change without notice.

DIGITAL TIMING (Guaranteed over –40°C to +105°C, AVDD = DVDD = 5.0 V ± 10%)

		Min	Unit
t_{DMP}	MCLK Period (FMCLK = $256 \times$ FLRCLK)	54	ns
t_{DML}	MCLK LO Pulsewidth (All Modes)	15	ns
t_{DMH}	MCLK HI Pulsewidth (All Modes)	10	ns
t_{DBH}	BCLK HI Pulsewidth	7	ns
t_{DBL}	BCLK LO Pulsewidth	12	ns
t_{DBP}	BCLK Period	60	ns
t_{DLS}	LRCLK Setup	20	ns
t_{DLH}	LRCLK Hold (DSP Serial Port Mode Only)	20	ns
t_{DDS}	SDATA Setup	15	ns
t_{DDH}	SDATA Hold	10	ns
t_{RSTL}	RST LO Pulsewidth	15	ns

Specifications subject to change without notice.

AD1959

ABSOLUTE MAXIMUM RATINGS*

DVDD to DGND	-0.3 V to +6 V
AVDD to DGND	-0.3 V to +6 V
Digital Inputs	DGND - 0.3 V to DVDD + 0.3 V
Analog Inputs	AGND - 0.3 V to AVDD + 0.3 V
AGND to DGND	-0.3 V to +0.3 V
Reference Voltage	(AVDD + 0.3)/2
Soldering (10 sec)	300°C

*Stresses above those listed under Absolute Maximum Ratings may cause permanent damage to the device. This is a stress rating only; functional operation of the device at these or any other conditions above those listed in the operational sections of this specification is not implied. Exposure to absolute maximum rating conditions for extended periods may affect device reliability. Only one absolute maximum rating may be applied at any one time.

PACKAGE CHARACTERISTICS

θ_{JA} (Thermal Resistance) Junction-to-Ambient	109.0°C/W Typ (2-Layer Board)
θ_{JA} (Thermal Resistance) Junction-to-Ambient	78.58°C/W Typ (4-Layer Board—2 Signal, 2 Planes)
θ_{JA} (Thermal Resistance) Junction-to-Case	39.0°C/W Typ

CAUTION

ESD (electrostatic discharge) sensitive device. Electrostatic charges as high as 4000 V readily accumulate on the human body and test equipment and can discharge without detection. Although the AD1959 features proprietary ESD protection circuitry, permanent damage may occur on devices subjected to high-energy electrostatic discharges. Therefore, proper ESD precautions are recommended to avoid performance degradation or loss of functionality.



ORDERING GUIDE

Model	Temperature	Package Description	Package Option
AD1959YRS	-40°C to +105 °C	28-Lead Small Outline Package	RS-28
AD1959YRSRL	-40°C to +105 °C	28-Lead Small Outline Package	RS-28 on 13" Reels
EVAL-AD1959EB		Evaluation Board	

PIN CONFIGURATION

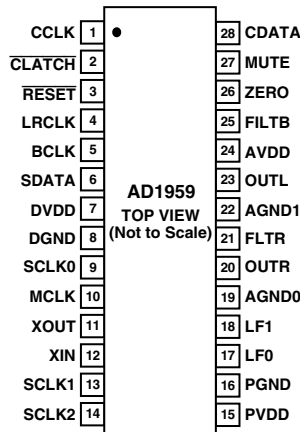

PIN FUNCTION DESCRIPTIONS

Pin	Input/Output	Mnemonic	Description
1	I	CCLK	Control Clock Input for Control Data. Control input data must be valid on the rising edge of CCLK. CCLK may be continuous or gated.
2	I	$\overline{\text{CLATCH}}$	Latch Input for Control Data.
3	I	$\overline{\text{RESET}}$	Reset. The AD1959 is placed in a reset mode when this pin is held LO. The serial control port registers are reset to their default values. Set HI for normal operation.
4	I	LRCLK	Left/Right Clock Input for Input Data. Must run continuously.
5	I	BCLK	Bit Clock Input for Input Data. Need not run continuously; may be gated or used in a burst fashion.
6	I	SDATA	Serial input, MSB first, containing two channels of 16/20/24 bits of two's-complement data per channel.
7	I	DVDD	Digital Power Supply Connect to Digital 5 V Supply.
8	I	DGND	Digital Ground.
9	O	SCLK0	33.8688 MHz Clock Output.
10	I/O	MCLK	27 MHz Master Clock Output/256 f _s DAC Clock Input.
11	O	XOUT	27 MHz Crystal Oscillator Output.
12	I	XIN	27 MHz Crystal Oscillator/External Clock Input.
13	O	SCLK1	256/384 f _s Output.
14	O	SCLK2	512 f _s /22.5792 MHz Output.
15		PVDD	PLL Power Supply. Connect to PLL 5 V Supply.
16		PGND	PLL Ground.
17		LF0	PLL0 Loop Filter.
18		LF1	PLL1 Loop Filter.
19		AGND0	Analog Ground.
20	O	OUTR	Right Channel Positive Line Level Analog Output.
21	O	FILTR	Voltage Reference Filter Capacitor Connection. Bypass and decouple the voltage reference with parallel 10 μF and 0.1 μF capacitors to AGND.
22	I	AGND1	Analog Ground.
23	O	OUTL	Left Channel Line Level Analog Output.
24		AVDD	Analog Power Supply. Connect to Analog 5 V Supply.
25		FILTB	Filter Capacitor Connection, Connect 10 μF Capacitor to AGND.
26	O	ZERO	Zero Flag Output. This pin goes HI when both channels have zero signal input for more than 1024 L/R Clock Cycles.
27	I	MUTE	Mute. Assert HI to Mute Both Stereo Analog Outputs. Deassert LO for normal operation.
28	I	CDATA	Serial control input, MSB first, containing 16 bits of unsigned data per channel.

AD1959

FUNCTIONAL DESCRIPTION

DAC

The AD1959 has two DAC channels arranged as a stereo pair with single-ended analog outputs. Each channel has its own independently programmable attenuator, adjustable in 16384 linear steps. Digital inputs are supplied through a serial data input pin, SDATA, a frame clock, LRCLK and a bit clock, BCLK.

Each analog output pin sits at a dc level of V_{REF} , and swings ± 1.585 V for a 0 dB digital input signal. A single op amp third-order external low-pass filter is recommended to remove high-frequency noise present on the output pins. The output phase can be changed in an SPI control register to accommodate inverting and noninverting filters. Note that the use of op amps with low slew rate or low bandwidth may cause high frequency noise and tones to fold down into the audio band; care should be exercised in selecting these components.

The FILTD and FILTR pins should be bypassed by external capacitors to ground. The FILTD pin is used to reduce the noise of the internal DAC bias circuitry, thereby reducing the DAC output noise. The voltage at the V_{REF} pin, FILTR (~2.39 V) can be used to bias external op amps used to filter the output signals.

The DAC master clock frequency is $256 f_s$ for the 32 kHz–48 kHz range. For the 96 kHz range this is $128 f_s$. It is supplied internally from the PLL clock system when MCLK mode is set to Output in the PLL Control Register. When the MCLK mode is changed to Input, it must be supplied from an external source connected to MCLK. The output from the 27 MHz PLL clock is disabled in this case.

PLL Clock System

The PLL clock system operates from a 27 MHz master clock supplied by the on-board crystal oscillator or an external source connected to XIN. With the MCLK mode set to Output, the

27 MHz clock is buffered out to the MCLK pin. When set to Input, the MCLK is the $256 f_s$ master clock input for the DAC. SCLK0 produces a 33.8688 MHz output, SCLK1 is intended to be used as a master audio clock and will be a multiple of the sample rate set in the PLL control register. It can be set to $256 f_s$ or $384 f_s$ using Bit 5 and to $512 f_s$ or $768 f_s$, with Bit 4. SCLK2 can be set to a constant 22.5792 MHz (512×44.1 kHz) or $512 f_s$ by Bit 3 of the PLL Control Register. Please note that SCLK2 is intended to operate a DSP and does not meet the jitter specifications stated under Analog Performance. All the generated clocks can be set to 1/2 their nominal rate by setting REF_Div2, Bit 8 in the PLL Control Register.

Reset

\overline{RESET} will set the control registers to their default settings. The chip should be reset on power-up. After reset is deasserted, the part will come out of reset on the next rising LRCLK.

Serial Control Port

The AD1959 has an SPI-compatible control port to permit programming the internal control registers for the PLL and DAC. The DAC output levels may be independently programmed by means of an internal digital attenuator adjustable in 16384 linear steps.

The SPI control port is a 3-wire serial control port. The format is similar to the Motorola SPI format except the input data word is 16 bits wide. Max serial bit clock frequency is 8 MHz and may be completely asynchronous to the PLL system or the DAC. Figure 1 shows the format of the SPI signal. Note that the CCLK can be gated or continuous, CLATCH should be low during the 16 active clocks.



Figure 1. Format of SPI Signal

POWER SUPPLY AND VOLTAGE REFERENCE

The AD1959 is designed for five-volt supplies. Separate power supply pins are provided for the analog, digital, and PLL sections. These pins should be bypassed with 100 nF ceramic chip capacitors, as close to the pins as possible, to minimize noise. A bulk aluminum electrolytic capacitor of at least 22 μF should also be provided on the same PC board. For best performance it is recommended that the analog supply be separate from the digital and PLL supply. It is recommended that all supplies be isolated by ferrite beads in series with each supply. It is expected that the digital and PLL sections will be run from a common supply but isolated from one another. It is important that the analog supply be as clean as possible.

The internal voltage reference is brought out on Pin 21 (FILTR) and should be bypassed as close as possible to the chip with a

parallel combination of 10 μF and 100 nF. The reference voltage may be used to bias external op amps to the common-mode voltage of the analog output signal pins. The current drawn from the V_{REF} pin should be limited to less than 50 μA .

SERIAL DATA PORTS – DATA FORMAT

The DAC serial data input mode defaults to $I^2\text{S}$. By changing Bits 4 and 5 in the DAC control register, the mode can be changed to RJ, DSP, or LJ. The word width defaults to 24 bits but can be changed by programming Bits 8 and 9 in the DAC Control Register.

Figure 2 shows the serial mode formats.

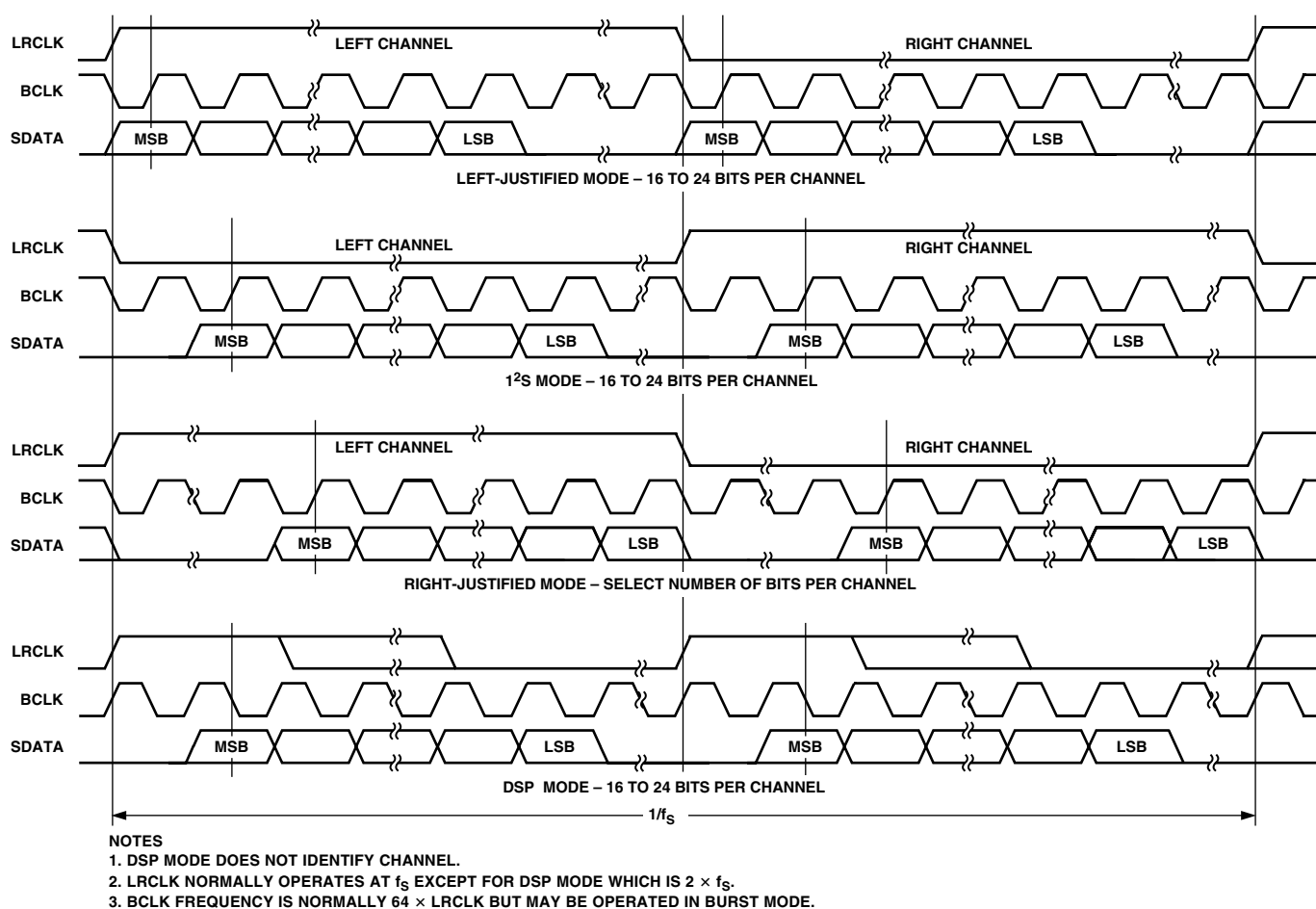

Figure 2. Stereo Serial Modes

Table I. DAC Control Register

Bit 11:10	Bit 9:8	Bit 7	Bit 6	Bit 5:4	Bit 3:2	Bit 1:0
Interpolation Factor	Serial Data Width	Output Phase	Soft Mute	Serial Data Format	De-Emphasis Filter	SPI Register Address
00 = 8×* 01 = 4× 10 = 2× 11 = Not Allowed	00 = 24 Bits* 01 = 20 Bits 10 = 16 Bits 11 = 16 Bits	0 = Noninverted* 1 = Inverted	0 = No Mute* 1 = Muted	00 = I ² S* 00 = Right Justified 10 = DSP 11 = Left Justified	00 = None* 01 = 44.1 kHz 10 = 32 kHz 11 = 48 kHz	01

*Default Setting.

Table II. DAC Volume Registers

Bit 15:2	Bit 1:0
Volume	SPI Register Address
14 Bits, Unsigned 14 Bits, Unsigned	00 = Left Volume 10 = Right Volume

Default is full volume.

Table III. PLL Control Register

Bit 11	Bit 10	Bit 9	Bit 8	Bit 7:6	Bit 5	Bit 4	Bit 3	Bit 2	Bit 1:0
PLL2 Power-Down	PLL1 Power-Down	XTAL Power-Down	REF_Div2 Power-Down	f_s	SCLK1 Select	Double	SCLK2 Select	MCLK Mode	SPI Register Address
0 = On* 1 = Power-Down	0 = On* 1 = Power-Down	0 = On* 1 = Power-Down	0 = No Div* 1 = Div by 2	00 = 48 kHz* 01 = Not Allowed 10 = 32 kHz 11 = 44.1 kHz	0 = 256* 1 = 384	0 = f_s * 1 = $2 \times f_s$	0 = 512×4.1 kHz* 1 = $512 \times f_s$	0 = Output* 1 = Input	11

*Default Setting.

OUTLINE DIMENSIONS

Dimensions shown in inches and (mm).

28-Lead Small Outline Package (SSOP) (RS-28)

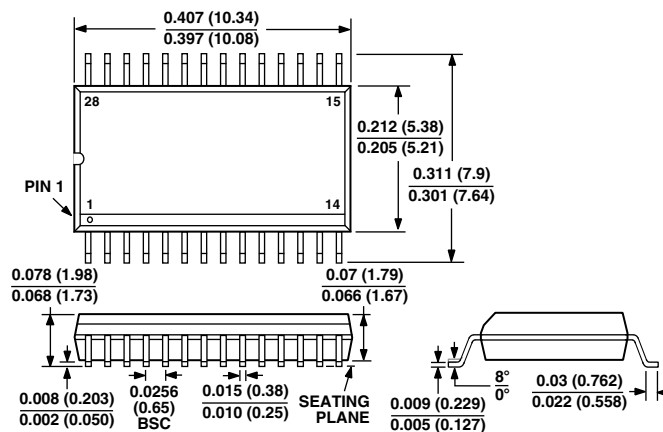

Looking for pricing, stock, or lifecycle information?

Click below to explore more details on WIN SOURCE:

 [View AD1959YRS on WIN SOURCE](#)

 [Analog Devices Inc. Information](#)

Optimize Your Supply Chain with WIN SOURCE Solutions

-  Global Sourcing Solution
-  Obsolete Management
-  Cost Control Management
-  Shortage Management
-  Alternative Solution
-  Excess Inventory Management