



**THE DATASHEET OF
AD1937WBSTZ**



FEATURES

- PLL-generated clock or direct master clock**
- Low EMI design**
- 112 dB DAC/107 dB ADC dynamic range and SNR**
- 96 dB THD + N**
- Single 3.3 V supply**
- Tolerance for 5 V logic inputs**
- Supports 24-bits and 8 kHz to 192 kHz sample rates**
- Differential ADC input**
- Differential DAC output**
- Log volume control with autoramp function**
- I²C-controllable for flexibility**
- Software-controllable clickless mute**
- Software power-down**
- Right-justified, left-justified, I²S, and TDM modes**
- Master and slave modes up to 16-channel input/output**
- Available in a 64-lead LQFP**
- Qualified for automotive applications**

APPLICATIONS

- Automotive audio systems**
- Home theater systems**
- Set-top boxes**
- Digital audio effects processors**

GENERAL DESCRIPTION

The AD1937 is a high performance, single-chip codec that provides four analog-to-digital converters (ADCs) with differential input and eight digital-to-analog converters (DACs) with differential output, using the Analog Devices, Inc., patented multibit sigma-delta (Σ - Δ) architecture. An I²C[®] port is included, allowing a microcontroller to adjust volume and many other parameters. The AD1937 operates from 3.3 V digital and analog supplies. The AD1937 is available in a 64-lead (differential output) LQFP.

The AD1937 is designed for low EMI. This consideration is apparent in both the system and circuit design architectures. By using the on-board PLL to derive the master clock from the LR (frame) clock or from an external crystal, the AD1937 eliminates the need for a separate high frequency master clock and can also be used with a suppressed bit clock. The DACs and ADCs are designed using the latest Analog Devices continuous time architecture to further minimize EMI. By using 3.3 V supplies, power consumption is minimized and further reduces emissions.

FUNCTIONAL BLOCK DIAGRAM

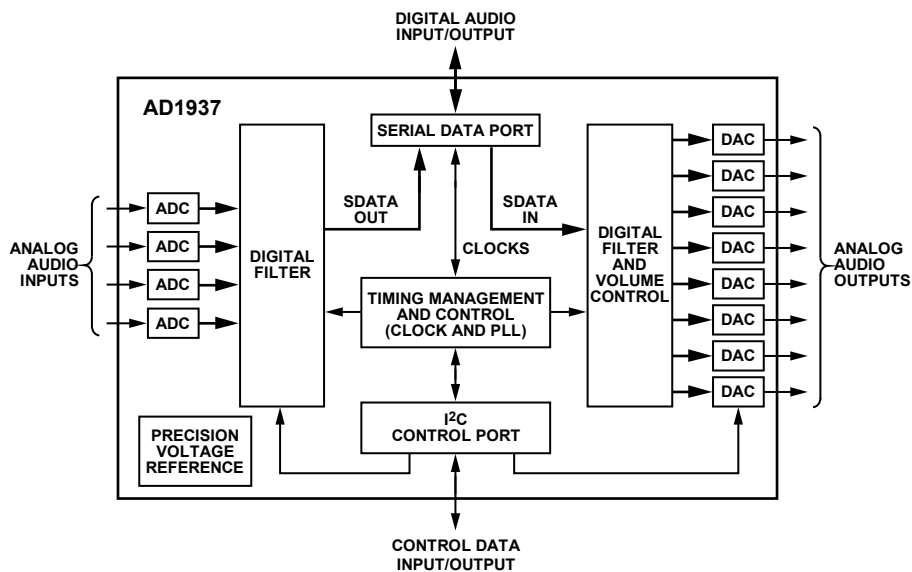

Figure 1.

07414-001

Rev. B

Information furnished by Analog Devices is believed to be accurate and reliable. However, no responsibility is assumed by Analog Devices for its use, nor for any infringements of patents or other rights of third parties that may result from its use. Specifications subject to change without notice. No license is granted by implication or otherwise under any patent or patent rights of Analog Devices. Trademarks and registered trademarks are the property of their respective owners.

TABLE OF CONTENTS

Features	1	Analog-to-Digital Converters (ADCs).....	15
Applications.....	1	Digital-to-Analog Converters (DACs)	15
General Description	1	Clock Signals.....	15
Functional Block Diagram	1	Reset and Power-Down	16
Revision History	2	I ² C Control Port.....	16
Specifications.....	3	Power Supply and Voltage Reference.....	18
Test Conditions.....	3	Serial Data Ports—Data Format.....	19
Analog Performance Specifications	3	Time-Division Multiplexed (TDM) Modes.....	20
Crystal Oscillator Specifications.....	5	Daisy-Chain Mode	23
Digital Specifications	6	Additional Modes.....	26
Power Supply Specifications.....	6	Control Registers.....	27
Digital Filters.....	7	Definitions.....	27
Timing Specifications	8	PLL and Clock Control Registers.....	27
Timing Diagrams.....	9	DAC Control Registers.....	28
Absolute Maximum Ratings.....	10	ADC Control Registers.....	30
Thermal Resistance	10	Applications Circuits.....	32
ESD Caution.....	10	Outline Dimensions	33
Pin Configuration and Function Descriptions.....	11	Ordering Guide	33
Typical Performance Characteristics	13	Automotive Products.....	33
Theory of Operation	15		

REVISION HISTORY

6/10—Rev. A to Rev. B

Changes to Table 3 Introductory Text and to Table 3.....	4
Changes to Table 5 Introductory Text	6
Changes to Table 8 Introductory Text	8

3/10—Rev. 0 to Rev. A

Changes to Ordering Guide	33
---------------------------------	----

9/08—Revision 0: Initial Version

SPECIFICATIONS

TEST CONDITIONS

Performance of all channels is identical, exclusive of the interchannel gain mismatch and interchannel phase deviation specifications.

Table 1.

Parameter	Value
Supply Voltages (AVDD, DVDD)	3.3 V
Temperature	As specified in Table 2 and Table 3
Master Clock	12.288 MHz (48 kHz f_s , 256 × f_s mode)
Input Sample Rate	48 kHz
Measurement Bandwidth	20 Hz to 20 kHz
Word Width	24 bits
Load Capacitance (Digital Output)	20 pF
Load Current (Digital Output)	±1 mA or 1.5 k Ω to ½ DVDD supply
Input Voltage High	2.0 V
Input Voltage Low	0.8 V

ANALOG PERFORMANCE SPECIFICATIONS

Specifications guaranteed at a T_A of 25°C.

Table 2.

Parameter	Conditions/Comments	Min	Typ	Max	Unit
ANALOG-TO-DIGITAL CONVERTERS					
ADC Resolution	All ADCs		24		Bits
Dynamic Range	20 Hz to 20 kHz, –60 dB input				
No Filter (RMS)		96	102		dB
With A-Weighted Filter (RMS)		98	105		dB
Total Harmonic Distortion + Noise	–1 dBFS		–96	–87	dB
Full-Scale Input Voltage (Differential)			1.9		V rms
Gain Error		–10		+10	%
Interchannel Gain Mismatch		–0.25		+0.25	dB
Offset Error		–10	0	+10	mV
Gain Drift			100		ppm/°C
Interchannel Isolation			–110		dB
CMRR	100 mV rms, 1 kHz		55		dB
	100 mV rms, 20 kHz		55		dB
Input Resistance			14		k Ω
Input Capacitance			10		pF
Input Common-Mode Bias Voltage			1.5		V
DIGITAL-TO-ANALOG CONVERTERS					
DAC Resolution	All DACs		24		Bits
Dynamic Range	20 Hz to 20 kHz, –60 dB input				
No Filter (RMS)		102	107		dB
With A-Weighted Filter (RMS)		105	110		dB
With A-Weighted Filter (Average)			112		dB

AD1937

Parameter	Conditions/Comments	Min	Typ	Max	Unit
Total Harmonic Distortion + Noise	0 dBFS				
	Two channels running		-94		dB
	Eight channels running		-86	-76	dB
Full-Scale Output Voltage			1.76 (4.96)		V rms (V p-p)
Gain Error		-10		+10	%
Interchannel Gain Mismatch		-0.2		+0.2	dB
Offset Error		-25	-6	+25	mV
Gain Drift		-30		+30	ppm/°C
Interchannel Isolation			100		dB
Interchannel Phase Deviation			0		Degrees
Volume Control Step			0.375		dB
Volume Control Range			95		dB
De-emphasis Gain Error				±0.6	dB
Output Resistance at Each Pin			100		Ω
REFERENCE					
Internal Reference Voltage	FILTR pin		1.50		V
External Reference Voltage	FILTR pin	1.32	1.50	1.68	V
Common-Mode Reference Output	CM pin		1.50		V
REGULATOR					
Input Supply Voltage	VSUPPLY pin	4.5	5	5.5	V
Regulated Output Voltage	VSENSE pin	3.19	3.37	3.55	V

Specifications measured at $-40^{\circ}\text{C} < T_c < +125^{\circ}\text{C}$, $AVDD = 3.3\text{ V} \pm 10\%$.

Table 3.

Parameter	Conditions/Comments	$-40^{\circ}\text{C} < T_c < +125^{\circ}\text{C}$, $AVDD = 3.3\text{ V} \pm 10\%$		Units
		Min	Max	
ANALOG-TO-DIGITAL CONVERTERS				
ADC Resolution	All ADCs		24	Bits
Dynamic Range	20 Hz to 20 kHz, -60 dB			
No Filter (RMS)		93		dB
With A-Weighted Filter (RMS)		95		dB
Total Harmonic Distortion + Noise	-1 dBFS		-85	dB
Full-Scale Input Voltage (Differential)		1.75	2.05	V rms
Gain Error		-10	+10	%
Interchannel Gain Mismatch		-0.46	+0.25	dB
Offset Error		-10	+10	mV
Gain Drift			100	ppm/°C
Interchannel Isolation		-105		dB
CMRR	100 mV rms, 1 kHz		42	dB
	100 mV rms, 20 kHz		42	dB
Input Resistance			By design	kΩ
Input Capacitance			By design	pF
Input Common-Mode Bias Voltage		1.45	1.55	V dc
DIGITAL-TO-ANALOG CONVERTERS				
DAC Resolution	All DACs		24	Bits
Dynamic Range	20 Hz to 20 kHz, -60 dB			
No Filter (RMS)		100		dB
With A-Weighted Filter (RMS)		104		dB
With A-Weighted Filter (Average)		109		dB
Total Harmonic Distortion + Noise	0 dBFS			
	Two channels		-84	dB
	Eight channels		-76	dB

Parameter	Conditions/Comments	-40°C < T _c < +125°C, AVDD = 3.3 V ± 10%		Units
		Min	Max	
Full-Scale Output Voltage		1.6	1.9	V rms (V p-p)
Gain Error		-10	+10	%
Interchannel Gain Mismatch		-0.2	+0.2	dB
Offset Error		-30	+25	mV
Gain Drift		-30	+30	ppm/°C
Interchannel Isolation		-95		dB
Interchannel Phase Deviation			By design	Degrees
Volume Control Step			By design	dB
Volume Control Range			By design	dB
De-emphasis Gain Error			By design	dB
Output Resistance at Each Pin			By design	Ω
REFERENCE				
Internal Reference Voltage	FILTR pin	1.46	1.57	V dc
External Reference Voltage	FILTR pin	1.32	1.68	V dc
Common-Mode Reference Output	CM pin	1.45	1.56	V dc
REGULATOR				
Input Supply Voltage	VSUPPLY pin	4.5	5.5	V dc
Regulated Output Voltage	VSENSE pin	3.05	3.71	V dc

CRYSTAL OSCILLATOR SPECIFICATIONS

Table 4.

Parameter	Min	Typ	Max	Unit
Transconductance		3.5		mmhos

AD1937

DIGITAL SPECIFICATIONS

$-40^{\circ}\text{C} < T_c < +125^{\circ}\text{C}$, DVDD = 3.3 V \pm 10%.

Table 5.

Parameter	Conditions/Comments	Min	Typ	Max	Unit
INPUT					
High Level Input Voltage (V_{IH})	MCLKI/MCLKXI pin	2.0			V
Low Level Input Voltage (V_{IL})		2.2			V
Input Leakage	I_{IH} @ $V_{IH} = 2.4$ V			0.8	V
	I_{IL} @ $V_{IL} = 0.8$ V			10	μA
Input Capacitance				10	μA
				5	pF
OUTPUT					
High Level Output Voltage (V_{OH})	$I_{OH} = 1$ mA	DVDD – 0.60			V
Low Level Output Voltage (V_{OL})	$I_{OL} = 1$ mA			0.4	V

POWER SUPPLY SPECIFICATIONS

Table 6.

Parameter	Conditions/Comments	Min	Typ	Max	Unit				
SUPPLIES									
Voltage	DVDD	3.0	3.3	3.6	V				
	AVDD	3.0	3.3	3.6	V				
	VSUPPLY	4.5	5.0	5.5	V				
Digital Current	Master clock = 256 f _s								
						Normal Operation	$f_s = 48$ kHz	56	mA
							$f_s = 96$ kHz	65	mA
							$f_s = 192$ kHz	95	mA
Power-Down	$f_s = 48$ kHz to 192 kHz		2.0	mA					
Analog Current									
						Normal Operation	74	mA	
Power-Down			23	mA					
DISSIPATION									
Operation	Master clock = 256 f _s , 48 kHz								
						All Supplies	429	mW	
						Digital Supply	185	mW	
						Analog Supply	244	mW	
Power-Down, All Supplies		83	mW						
POWER SUPPLY REJECTION RATIO									
Signal at Analog Supply Pins	1 kHz, 200 mV p-p		50		dB				
	20 kHz, 200 mV p-p		50		dB				

DIGITAL FILTERS

Table 7.

Parameter	Mode	Factor	Min	Typ	Max	Unit
ADC DECIMATION FILTER	All modes, typical @ 48 kHz					
Pass Band		$0.4375 \times f_s$		21		kHz
Pass-Band Ripple				± 0.015		dB
Transition Band		$0.5 \times f_s$		24		kHz
Stop Band		$0.5625 \times f_s$		27		kHz
Stop-Band Attenuation			79			dB
Group Delay		$22.9844 \div f_s$		479		μs
DAC INTERPOLATION FILTER						
Pass Band	48 kHz mode, typical @ 48 kHz	$0.4535 \times f_s$		22		kHz
	96 kHz mode, typical @ 96 kHz	$0.3646 \times f_s$	35			kHz
	192 kHz mode, typical @ 192 kHz	$0.3646 \times f_s$		70		kHz
Pass-Band Ripple	48 kHz mode, typical @ 48 kHz				± 0.01	dB
	96 kHz mode, typical @ 96 kHz				± 0.05	dB
	192 kHz mode, typical @ 192 kHz				± 0.1	dB
Transition Band	48 kHz mode, typical @ 48 kHz	$0.5 \times f_s$		24		kHz
	96 kHz mode, typical @ 96 kHz	$0.5 \times f_s$		48		kHz
	192 kHz mode, typical @ 192 kHz	$0.5 \times f_s$		96		kHz
Stop Band	48 kHz mode, typical @ 48 kHz	$0.5465 \times f_s$		26		kHz
	96 kHz mode, typical @ 96 kHz	$0.6354 \times f_s$		61		kHz
	192 kHz mode, typical @ 192 kHz	$0.6354 \times f_s$		122		kHz
Stop-Band Attenuation	48 kHz mode, typical @ 48 kHz		70			dB
	96 kHz mode, typical @ 96 kHz		70			dB
	192 kHz mode, typical @ 192 kHz		70			dB
Group Delay	48 kHz mode, typical @ 48 kHz	$25 \div f_s$		521		μs
	96 kHz mode, typical @ 96 kHz	$11 \div f_s$		115		μs
	192 kHz mode, typical @ 192 kHz	$8 \div f_s$		42		μs

AD1937

TIMING SPECIFICATIONS

-40°C < T_c < +125°C, DVDD = 3.3 V ± 10%.

Table 8.

Parameter	Condition	Comments	Min	Max	Unit
INPUT MASTER CLOCK (MCLK) AND RESET					
t _{MH}	MCLK duty cycle	DAC/ADC clock source = PLL clock @ 256 f _s , 384 f _s , 512 f _s , and 768 f _s	40	60	%
t _{MH}		DAC/ADC clock source = direct MCLK @ 512 f _s (bypass on-chip PLL)	40	60	%
f _{MCLK}	MCLK frequency	PLL mode, 256 f _s reference	6.9	13.8	MHz
f _{MCLK}		Direct 512 f _s mode		27.6	MHz
t _{PDR}	Low		15		ns
t _{PDRR}	Recovery	Reset to active output	4096		t _{MCLK}
PLL					
Lock Time	MCLK or LRCLK			10	ms
256 f _s VCO Clock, Output Duty Cycle, MCLKO/MCLKXO Pin			40	60	%
I²C					
f _{SCL}	SCL clock frequency	See Figure 13 and Figure 14		400	kHz
t _{SCLL}	SCL low		1.3		μs
t _{SCLH}	SCL high		0.6		μs
t _{SCS}	Setup time (start condition)	Relevant for repeated start condition	0.6		μs
t _{SCH}	Hold time (start condition)	First clock generated after this period	0.6		μs
t _{SSH}	Setup time (stop condition)		0.6		μs
t _{DS}	Data setup time		100		ns
t _{SR}	SDA and SCL rise time			300	ns
t _{SF}	SDA and SCL fall time			300	ns
t _{BFT}	Bus-free time	Between stop and start	1.3		μs
DAC SERIAL PORT					
t _{DBH}	DBCLK high	See Figure 2 Slave mode	10		ns
t _{DBL}	DBCLK low	Slave mode	10		ns
t _{DLS}	DLRCLK setup	To DBCLK rising, slave mode	10		ns
t _{DLH}	DLRCLK skew	From DBCLK falling, master mode	-8	+8	ns
t _{DLH}	DLRCLK hold	From DBCLK rising, slave mode	5		ns
t _{DDS}	DSDATA setup	To DBCLK rising	10		ns
t _{DDH}	DSDATA hold	From DBCLK rising	5		ns
ADC SERIAL PORT					
t _{ABH}	ABCLK high	See Figure 3 Slave mode	10		ns
t _{ABL}	ABCLK low	Slave mode	10		ns
t _{ALS}	ALRCLK setup	To ABCLK rising, slave mode	10		ns
t _{ALH}	ALRCLK skew	From ABCLK falling, master mode	-8	+8	ns
t _{ALH}	ALRCLK hold	From ABCLK rising, slave mode	5		ns
t _{ABDD}	ASDATA delay	From ABCLK falling, any mode		18	ns
AUXILIARY INTERFACE					
t _{AXDS}	AAUXDATA setup	To AUXBCLK rising	10		ns
t _{AXDH}	AAUXDATA hold	From AUXBCLK rising	5		ns
t _{DXDD}	DAUXDATA delay	From AUXBCLK falling		18	ns
t _{XBH}	AUXBCLK high		10		ns
t _{XBL}	AUXBCLK low		10		ns
t _{DLS}	AUXLRCLK setup	To AUXBCLK rising	10		ns
t _{DLH}	AUXLRCLK hold	From AUXBCLK rising	5		ns

TIMING DIAGRAMS

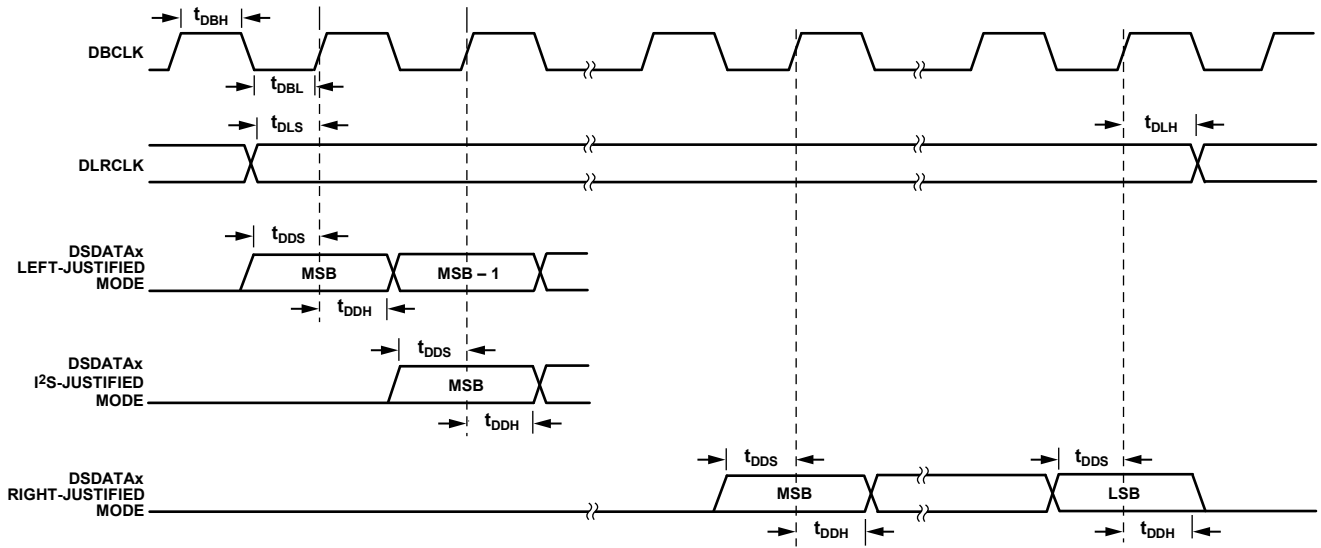

Figure 2. DAC Serial Timing

07414-025

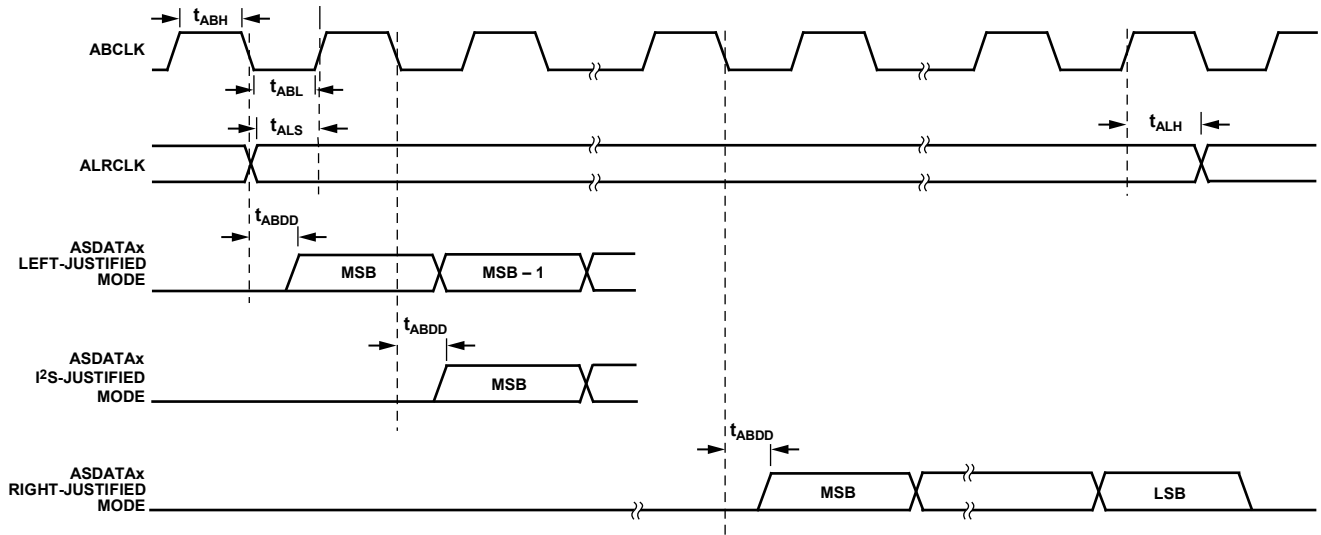

Figure 3. ADC Serial Timing

07414-026

ABSOLUTE MAXIMUM RATINGS

Table 9.

Parameter	Rating
Analog (AVDD)	-0.3 V to +3.6 V
Digital (DVDD)	-0.3 V to +3.6 V
VSUPPLY	-0.3 V to +6.0 V
Input Current (Except Supply Pins)	±20 mA
Analog Input Voltage (Signal Pins)	-0.3 V to AVDD + 0.3 V
Digital Input Voltage (Signal Pins)	-0.3 V to DVDD + 0.3 V
Operating Temperature Range (Case)	-40°C to +125°C
Storage Temperature Range	-65°C to +150°C

Stresses above those listed under Absolute Maximum Ratings may cause permanent damage to the device. This is a stress rating only; functional operation of the device at these or any other conditions above those indicated in the operational section of this specification is not implied. Exposure to absolute maximum rating conditions for extended periods may affect device reliability.

THERMAL RESISTANCE

θ_{JA} represents junction-to-ambient thermal resistance;

θ_{JC} represents the junction-to-case thermal resistance.

All characteristics are for a 4-layer board.

Table 10.

Package Type	θ_{JA}	θ_{JC}	Unit
64-Lead LQFP	47	11.1	°C/W

ESD CAUTION



ESD (electrostatic discharge) sensitive device.

Charged devices and circuit boards can discharge without detection. Although this product features patented or proprietary protection circuitry, damage may occur on devices subjected to high energy ESD. Therefore, proper ESD precautions should be taken to avoid performance degradation or loss of functionality.

PIN CONFIGURATION AND FUNCTION DESCRIPTIONS

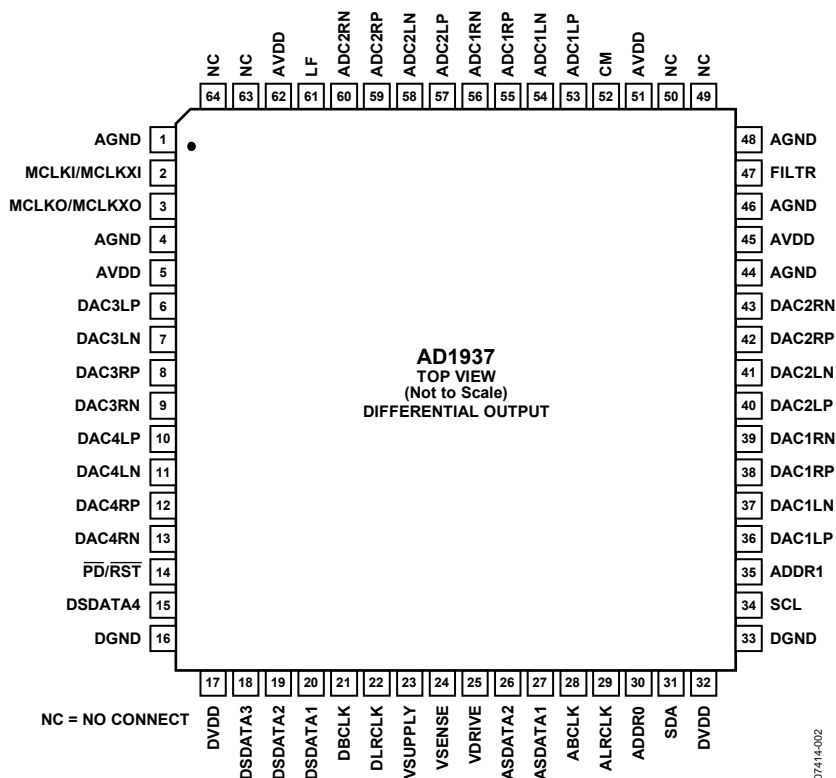

Figure 4. Pin Configuration

Table 11. Pin Function Descriptions

Pin No.	Type ¹	Mnemonic	Description
1, 4, 44, 46, 48	I	AGND	Analog Ground.
2	I	MCLKI/MCLKXI	Master Clock Input/Crystal Oscillator Input.
3	O	MCLKO/MCLKXO	Master Clock Output/Crystal Oscillator Output.
5, 45, 51, 62	I	AVDD	Analog Power Supply. Connect this pin to analog 3.3 V supply.
6	O	DAC3LP	DAC3 Left Positive Output.
7	O	DAC3LN	DAC3 Left Negative Output.
8	O	DAC3RP	DAC3 Right Positive Output.
9	O	DAC3RN	DAC3 Right Negative Output.
10	O	DAC4LP	DAC4 Left Positive Output.
11	O	DAC4LN	DAC4 Left Negative Output.
12	O	DAC4RP	DAC4 Right Positive Output.
13	O	DAC4RN	DAC4 Right Negative Output
14	I	$\overline{\text{PD/RST}}$	Power-Down Reset (Active Low).
15	I/O	DSDATA4	DAC Serial Data Input 4. Data input to DAC4 data in/TDM DAC2 data out (dual-line mode)/AUX DAC2 data out (to external DAC2).
16, 33	I	DGND	Digital Ground.
17, 32	I	DVDD	Digital Power Supply. Connect this pin to digital 3.3 V supply.
18	I/O	DSDATA3	DAC Serial Data Input 3. Data input to DAC3 data in/TDM DAC2 data in (dual-line mode)/AUX ADC2 data in (from external ADC2).
19	I/O	DSDATA2	DAC Serial Data Input 2. Data input to DAC2 data in/TDM DAC data out/AUX ADC1 data in (from external ADC1).
20	I	DSDATA1	DAC Serial Data Input 1. Data input to DAC1 data in/TDM DAC data in/TDM data in.
21	I/O	DBCLK	Bit Clock for DACs. Can be programmed as input or output in all modes.
22	I/O	DLRCLK	Frame Clock for DACs. Can be programmed as input or output in all modes.

AD1937

Pin No.	Type ¹	Mnemonic	Description
23	I	VSUPPLY	5 V Input to Regulator, Emitter of Pass Transistor.
24	I	VSENSE	Connect 3.3 V Regulator Output, Collector of Pass Transistor, to This Pin.
25	O	VDRIVE	Drive for Base of Pass Transistor.
26	I/O	ASDATA2	ADC Serial Data Output 2. Data Output from ADC2/TDM ADC data in/AUX DAC1 data out (to external DAC1).
27	O	ASDATA1	ADC Serial Data Output 1. Data Output from ADC1/TDM ADC data out/TDM data out.
28	I/O	ABCLK	Bit Clock for ADCs. Can be programmed as input or output in all modes.
29	I/O	ALRCLK	Frame Clock for ADCs. Can be programmed as input or output in all modes.
30	I	ADDR0	I ² C Address Assignment.
31	I/O	SDA	Control Data Port (I ² C).
34	I	SCL	Control Clock Port (I ² C).
35	I	ADDR1	I ² C Address Assignment.
36	O	DAC1LP	DAC1 Left Positive Output.
37	O	DAC1LN	DAC1 Left Negative Output.
38	O	DAC1RP	DAC1 Right Positive Output.
39	O	DAC1RN	DAC1 Right Negative Output.
40	O	DAC2LP	DAC2 Left Positive Output.
41	O	DAC2LN	DAC2 Left Negative Output.
42	O	DAC2RP	DAC2 Right Positive Output.
43	O	DAC2RN	DAC2 Right Negative Output.
47	O	FILTR	Analog Voltage Reference Filter Capacitor Connection. Bypass with 10 μ F 100 nF to AGND.
49, 50, 63, 64		NC	No Connect.
52	O	CM	Common-Mode Reference Filter Capacitor Connection. Bypass with 47 μ F 100 nF to AGND.
53	I	ADC1LP	ADC1 Left Positive Input.
54	I	ADC1LN	ADC1 Left Negative Input.
55	I	ADC1RP	ADC1 Right Positive Input.
56	I	ADC1RN	ADC1 Right Negative Input.
57	I	ADC2LP	ADC2 Left Positive Input.
58	I	ADC2LN	ADC2 Left Negative Input.
59	I	ADC2RP	ADC2 Right Positive Input.
60	I	ADC2RN	ADC2 Right Negative Input.
61	O	LF	PLL Loop Filter, Return to AVDD.

¹ I = input, O = output.

TYPICAL PERFORMANCE CHARACTERISTICS

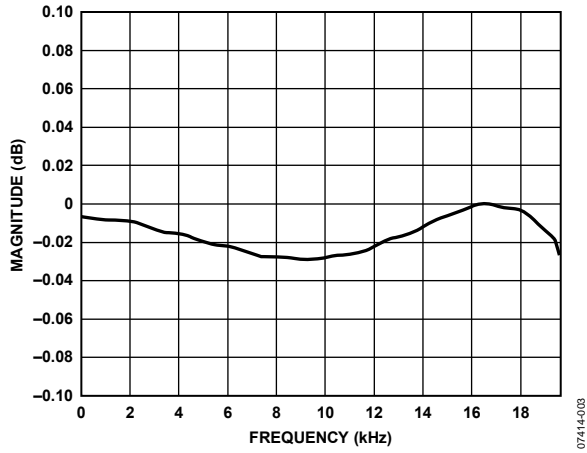

Figure 5. ADC Pass-Band Filter Response, 48 kHz

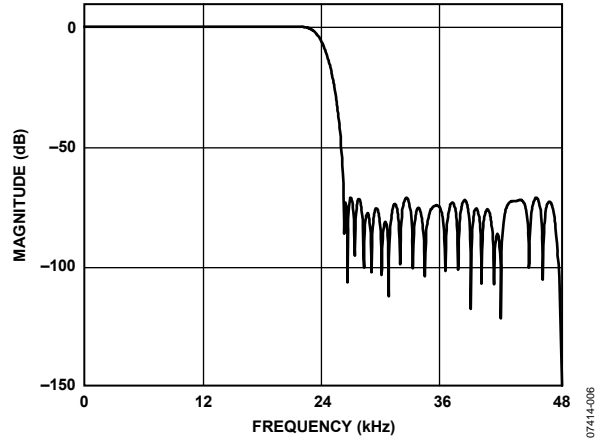

Figure 8. DAC Stop-Band Filter Response, 48 kHz

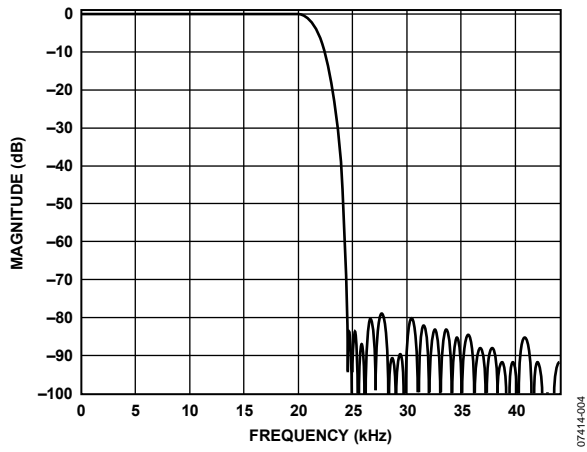

Figure 6. ADC Stop-Band Filter Response, 48 kHz

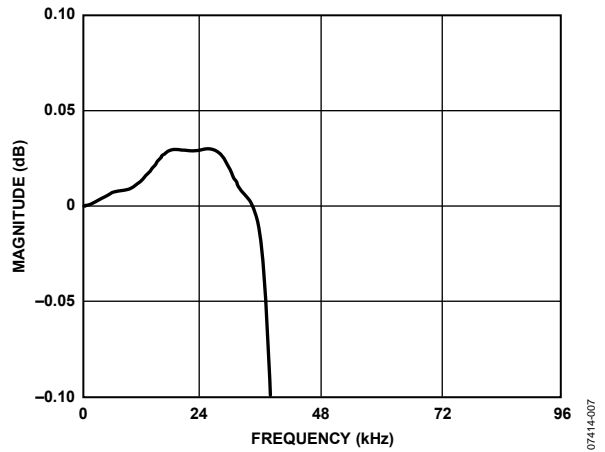

Figure 9. DAC Pass-Band Filter Response, 96 kHz

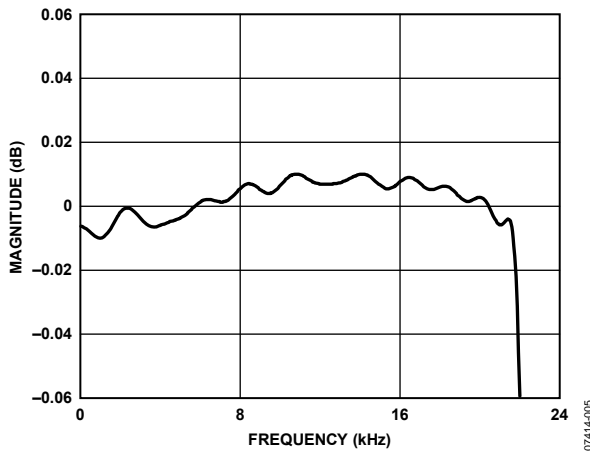

Figure 7. DAC Pass-Band Filter Response, 48 kHz

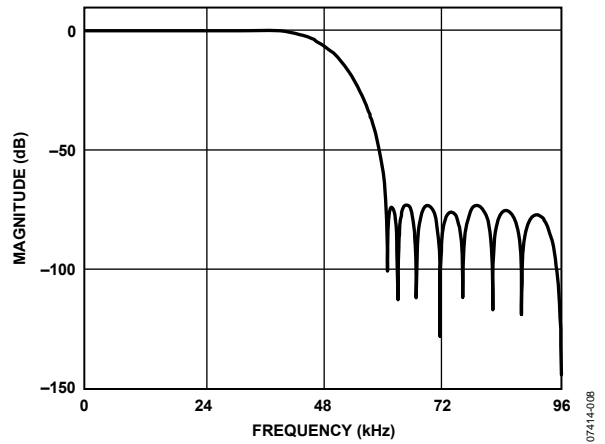

Figure 10. DAC Stop-Band Filter Response, 96 kHz

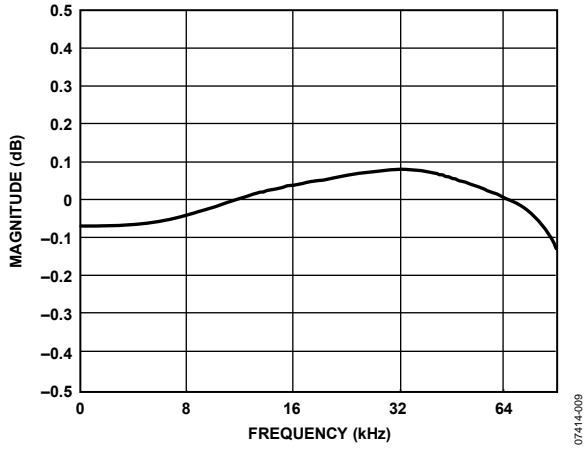

Figure 11. DAC Pass-Band Filter Response, 192 kHz

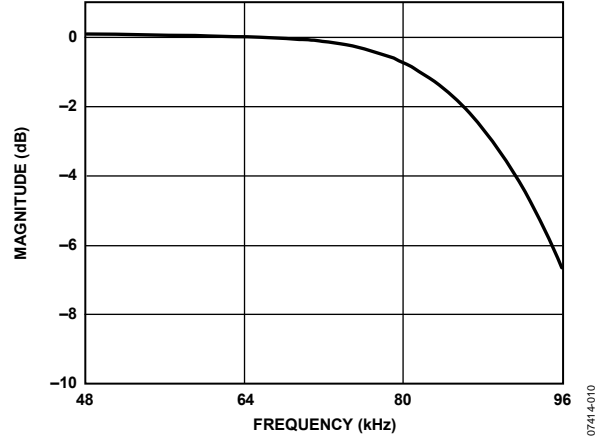

Figure 12. DAC Stop-Band Filter Response, 192 kHz

THEORY OF OPERATION

ANALOG-TO-DIGITAL CONVERTERS (ADCs)

There are four ADC channels in the AD1937 configured as two stereo pairs with differential inputs. The ADCs can operate at a nominal sample rate of 48 kHz, 96 kHz, or 192 kHz. The ADCs include on-board digital antialiasing filters with 79 dB stop-band attenuation and linear phase response, operating at an oversampling ratio of 128 (48 kHz, 96 kHz, and 192 kHz modes). Digital outputs are supplied through two serial data output pins (one for each stereo pair): a common frame clock (ALRCLK) and a common bit clock (ABCLK). Alternatively, the TDM modes can be used to access up to 16 channels on a single TDM data line.

The ADCs must be driven from a differential signal source for best performance. The input pins of the ADCs connect to internal switched capacitors. To isolate the external driving op amp from the glitches caused by the internal switched capacitors, each input pin should be isolated by using a series-connected external 100 Ω resistor and a 1 nF capacitor connected from each input to ground. Use a high quality capacitor such as a ceramic NP0/C0G, or polypropylene film.

The differential inputs have a nominal common-mode voltage of 1.5 V. The voltage at the common-mode reference pin (CM) can be used to bias external op amps to buffer the input signals (see the Power Supply and Voltage Reference section). The inputs can also be ac-coupled and in that case do not need an external dc bias to CM.

A digital high-pass filter can be switched in line with the ADCs (ADC Control 0 Register) to remove residual dc offsets. It has a 1.4 Hz, 6 dB per octave cutoff at a 48 kHz sample rate. The cutoff frequency scales directly with sample frequency.

DIGITAL-TO-ANALOG CONVERTERS (DACs)

The AD1937 DAC channels are arranged in four stereo pairs, giving eight analog outputs; the outputs are differential for improved noise and distortion performance. The DACs include on-board digital reconstruction filters with 70 dB stop-band attenuation and linear phase response, operating at an oversampling ratio of 4 (48 kHz or 96 kHz modes) or 2 (192 kHz mode). Each channel has its own independently programmable attenuator, adjustable in 255 steps in increments of 0.375 dB. Digital inputs are supplied through four serial data input pins (one for each stereo pair), a common frame clock (DLRCLK), and a common bit clock (DBCLK). Alternatively, one of the TDM modes can be used to access up to 16 channels on a single TDM data line.

Each output pin has a nominal common-mode dc level of 1.5 V and swings ± 1.27 V for a 0 dBFS digital input signal. A single op amp, third-order, external, low-pass filter is recommended to remove high frequency noise present on the output pins, as well as to provide a differential-to-single-ended conversion for the differential output. Note that the use of op amps with low slew rates or low bandwidth can cause high frequency noise and tones to fold down into the audio band; exercise care in selecting these components.

The voltage at CM can be used to bias the external op amps that buffer the output signals (see the Power Supply and Voltage Reference section).

CLOCK SIGNALS

The on-chip phase-locked loop (PLL) can be selected to reference the input sample rate from either of the LRCLK pins or 256 \times , 384 \times , 512 \times , or 768 \times sample rate s (f_s), referenced to the 48 kHz mode from the MCLKI/MCLKXI pin. The default at power-up is 256 \times f_s from the MCLKI/MCLKXI pin. In 96 kHz mode, the master clock frequency stays at the same absolute frequency; therefore, the actual multiplication rate is divided by 2. In 192 kHz mode, the actual multiplication rate is divided by 4. For example, if the AD1937 is programmed in 256 \times f_s mode, the frequency of the master clock input is 256 \times 48 kHz = 12.288 MHz. If the AD1937 is then switched to 96 kHz operation (by writing to the I²C port), the frequency of the master clock should remain at 12.288 MHz, which is 128 \times f_s in this example. In 192 kHz mode, this becomes 64 \times f_s .

The internal clock for the ADCs is 256 \times f_s for all clock modes. The internal clock for the DACs varies by mode: 512 \times f_s (48 kHz mode), 256 \times f_s (96 kHz mode), or 128 \times f_s (192 kHz mode). By default, the on-board PLL generates this internal master clock from an external clock. A direct 512 \times f_s (referenced to 48 kHz mode) master clock can be used for either the ADCs or DACs, if selected in the PLL and Clock Control 1 register.

Note that it is not possible to use a direct clock for the ADCs set to the 192 kHz mode. It is required that the on-chip PLL be used in this mode.

The PLL can be powered down in the PLL and Clock Control 0 Register. To ensure reliable locking when changing PLL modes, or if the reference clock is unstable at power-on, power down the PLL and then power it back up after the reference clock has stabilized.

The internal master clock (MCLK) can be disabled in the PLL and Clock Control 0 register to reduce power dissipation when the AD1937 is idle. The clock should be stable before it is enabled. Unless a standalone mode is selected (see the I²C Control Port section), the clock is disabled by reset and must be enabled by writing to the I²C port for normal operation.

AD1937

To maintain the highest performance possible, limit the clock jitter of the internal master clock signal to less than a 300 ps rms time interval error (TIE). Even at these levels, extra noise or tones can appear in the DAC outputs if the jitter spectrum contains large spectral peaks. If the internal PLL is not used, it is best to use an independent crystal oscillator to generate the master clock. In addition, it is especially important that the clock signal not pass through an FPGA, CPLD, or other large digital chip (such as a DSP) before being applied to the AD1937. In most cases, this induces clock jitter due to the sharing of common power and ground connections with other unrelated digital output signals. When the PLL is used, jitter in the reference clock is attenuated above a certain frequency depending on the loop filter.

RESET AND POWER-DOWN

The function of the $\overline{\text{PD/RST}}$ pin sets all the control registers to their default settings. To avoid audio pops, $\overline{\text{PD/RST}}$ does not power down the analog outputs. After $\overline{\text{PD/RST}}$ is deasserted and the PLL acquires lock condition, an initialization routine runs inside the AD1937. This initialization lasts for approximately 256 master clock cycles. Once the routine is complete, the registers can be programmed.

The power-down bits in the PLL and Clock Control 0, DAC Control 1, and ADC Control 1 registers power down their respective sections. All other register settings are retained. To guarantee proper startup, the $\overline{\text{PD/RST}}$ pin should be pulled low by an external resistor.

I²C CONTROL PORT

The AD1937 has an I²C-compatible control port that permits programming and reading back the internal control registers for the ADCs, DACs, and clock system. There is also a stand-alone mode available for operation without serial control, configured at reset using the serial control pins. All registers are set to default except internal MCLK enable, which is set to 1 and ADC BCLK and LRCLK master/slave is set by SDA (see Table 12 for details).

Table 12. Hardware Selection of Standalone Mode

ADC Clocks	ADDR0 (Pin 30)	SDA (Pin 31)	SCL (Pin 34)	ADDR1 (Pin 35)
Slave	0	0	0	0
Master	0	1	0	0

The I²C interface of the AD1937 is a 2-wire interface that consists of a clock line (SCL) and a data line (SDA). SDA is bidirectional and the AD1937 drives SDA either to acknowledge the master (ACK) or to send data during a read operation. The SDA pin for the I²C port is an open-drain collector and requires a 2 k Ω pull-up resistor. A write or read access occurs when the SDA line is pulled low while the SCL line is high, indicated by start in the timing diagrams. SDA is only allowed to change when SCL is low except when a start or stop condition occurs, as shown in Figure 13 and Figure 14. The first eight bits of the data-word consist of the device address and the R/W bit. The device address consists of an internal built-in address (0x08) ORed with the two address bits, ADDR1 and ADDR0, and the R/W bit. The two address bits allow four AD1937s to be used in a system. Tie I²C ADDR0 and ADDR1 low or high and program the ADDR bits accordingly as 0 or 1. Initiating a write operation to the AD1937 involves sending a start condition and then sending the device address with the R/W bit set low. The AD1937 responds by issuing an acknowledge to indicate that it has been addressed. The user then sends a second frame telling the AD1937 which register is required to be written to. Another acknowledge is issued by the AD1937. Finally, the user can send another frame with the eight data bits required to be written to the register. A third acknowledge is issued by the AD1937 after which the user can send a stop condition to complete the data transfer.

A read operation requires that the user first write to the AD1937 to point to the correct register and then read the data. This is achieved by sending a start condition followed by the device address frame, with the R/W bit low; the AD1937 returns an acknowledge. The master then sends the register address frame. Following the acknowledge from the AD1937, the user must issue a repeated start condition. The next frame is the device address with the R/W bit set high; the AD1937 returns an acknowledge. On the next frame, the AD1937 outputs the register data on the SDA line; the master should send an acknowledge. A stop condition completes the read operation. Figure 13 and Figure 14 show examples of writing to and reading from the DAC1L volume control register, Address 0x06 (see Table 28).

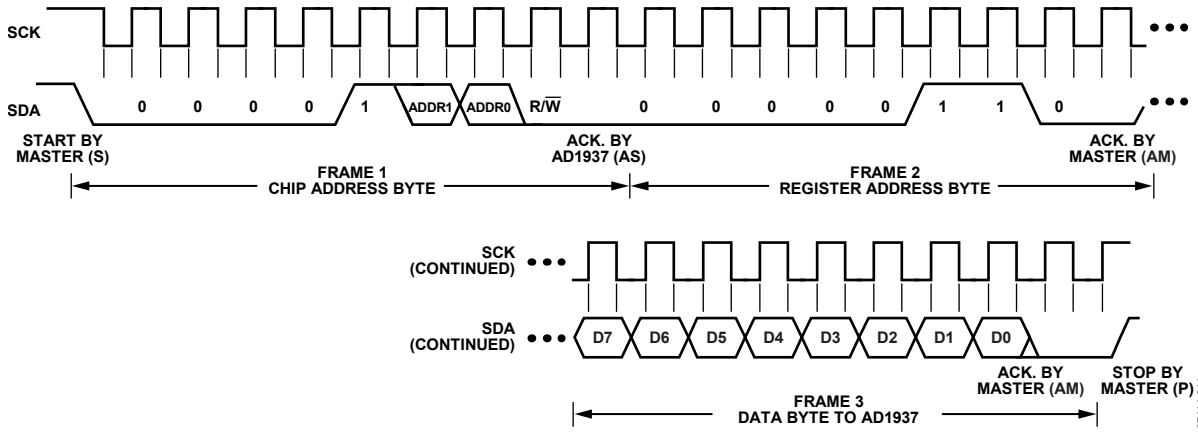

Figure 13. I²C Write Format

07414-011

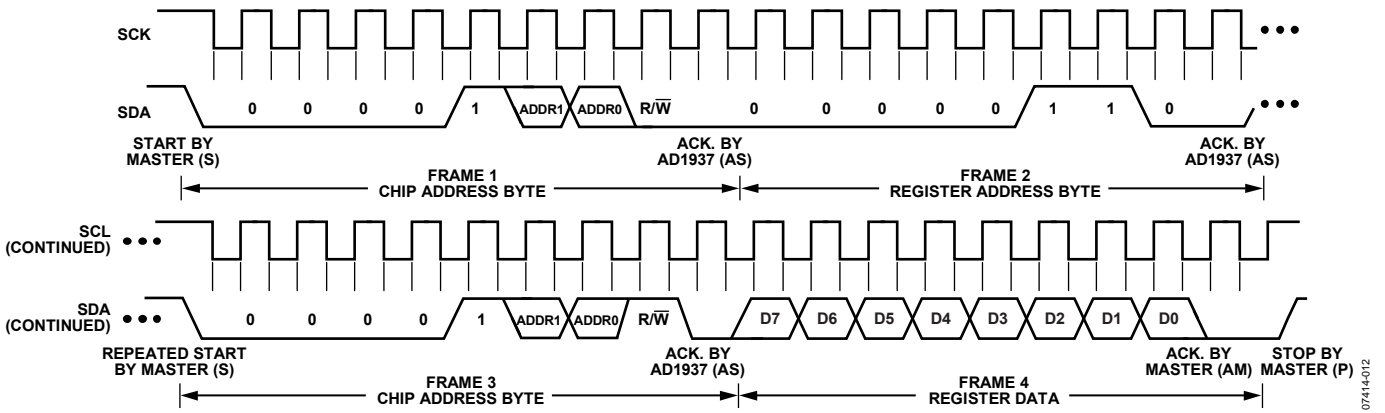

Figure 14. I²C Read Format

07414-012

AD1937

Table 13. I²C Abbreviation Table

Abbreviation	Condition
S	Repeated start by master
P	Stop by master
AM	Acknowledge by master
AS	Acknowledge by AD1937

Table 14. Single Word I²C Write

S	Chip Address, $\overline{R/W} = 0$	AS	Register Address	AS	Data Word	AS	P
---	------------------------------------	----	------------------	----	-----------	----	---

Table 15. Burst Mode I²C Write

S	Chip Address, $\overline{R/W} = 0$	AS	Register Address	AS	Data Word 1	AS	Data Word 2	AS	Data Word N	AS	P
---	------------------------------------	----	------------------	----	-------------	----	-------------	----	-------------	----	---

Table 16. Single Word I²C Read

S	Chip Address, $\overline{R/W} = 0$	AS	Register Address	AS	S	Chip Address, $\overline{R/W} = 1$	AS	Data Word	AM	P
---	------------------------------------	----	------------------	----	---	------------------------------------	----	-----------	----	---

Table 17. Burst Mode I²C Read

S	Chip Address, $\overline{R/W} = 0$	AS	Register Address	AS	S	Chip Address, $\overline{R/W} = 1$	AS	Data Word 1	AM	Data Word 2	AM	Data Word N	AM	P
---	------------------------------------	----	------------------	----	---	------------------------------------	----	-------------	----	-------------	----	-------------	----	---

POWER SUPPLY AND VOLTAGE REFERENCE

The AD1937 is designed for a 3.3 V supply. Separate power supply pins are provided for the analog and digital sections. To minimize noise pickup, these pins should be bypassed with 100 nF ceramic chip capacitors placed as close to the pins as possible. A bulk aluminum electrolytic capacitor of at least 22 μ F should also be provided on the same printed circuit board (PCB) as the codec. For critical applications, improved performance is obtained with separate supplies for the analog and digital sections. If this is not possible, it is recommended that the analog and digital load pins be isolated by means of a ferrite bead in series with the supply. It is important that the analog supply be as clean as possible.

The AD1937 includes a 3.3 V regulator driver that only requires an external pass transistor, a resistor, and bypass capacitors to turn a 5 V supply into 3.3 V. If the regulator driver is not used, connect VSUPPLY, VDRIVE, and VSENSE to DGND.

All digital inputs are compatible with TTL and CMOS levels. All outputs are driven from the 3.3 V DVDD supply and are compatible with TTL and 3.3 V CMOS levels.

The ADC and DAC internal analog voltage reference (V_{REF}) is brought out on the FILTR pin and should be bypassed as close as possible to the chip with a parallel combination of 10 μ F and 100 nF capacitors. Any external current drawn should be limited to less than 50 μ A.

The internal reference can be disabled in the PLL and Clock Control 1 register, and FILTR can be driven from an external source. This can be used to scale the DAC output to the clipping level of a power amplifier based on its power supply voltage. The ADC input gain varies by the inverse ratio. It is not advisable to drive the FILTR pin with more than $(AVDD/2)$ V. The total gain from ADC input to DAC output remains constant.

The CM pin should be bypassed as close as possible to the chip, with a parallel combination of 47 μ F and 100 nF capacitors. This voltage can be used to bias external op amps to the common-mode voltage of the input and output signal pins. The output current should be limited to less than 0.5 mA source and 2 mA sink.

SERIAL DATA PORTS—DATA FORMAT

The eight DAC channels use a common serial bit clock (DBCLK) and a common left-right framing clock (DLRCLK) in the serial data port. The four ADC channels use a common serial bit clock (ABCLK) and left-right framing clock (ALRCLK) in the serial data port. The clock signals are all synchronous with the sample rate. The normal stereo serial modes are shown in Figure 15.

The ADC and DAC serial data modes default to I²S stereo. The ports can also be programmed for left-justified stereo, right-justified stereo, and TDM modes. The word width is

24 bits by default and can be set to 16 or 20 bits in the DAC Control 2 and ADC Control 1 registers. The DAC serial formats are programmable in the DAC Control 0 register. The polarity of DBCLK and DLRCLK is programmable in the DAC Control 1 register. The ADC serial format is programmable in ADC Control 1 register. The ABCLK and ALRCLK clock polarities are programmed in ADC Control 2 register. In Figure 2, Figure 3, and Figure 15 all of the clocks are shown with their normal polarity. Both DAC and ADC serial ports can be programmed to become the bus masters according to DAC Control 1 and ADC Control 2 registers. By default, both ADC and DAC serial ports are in the slave mode.

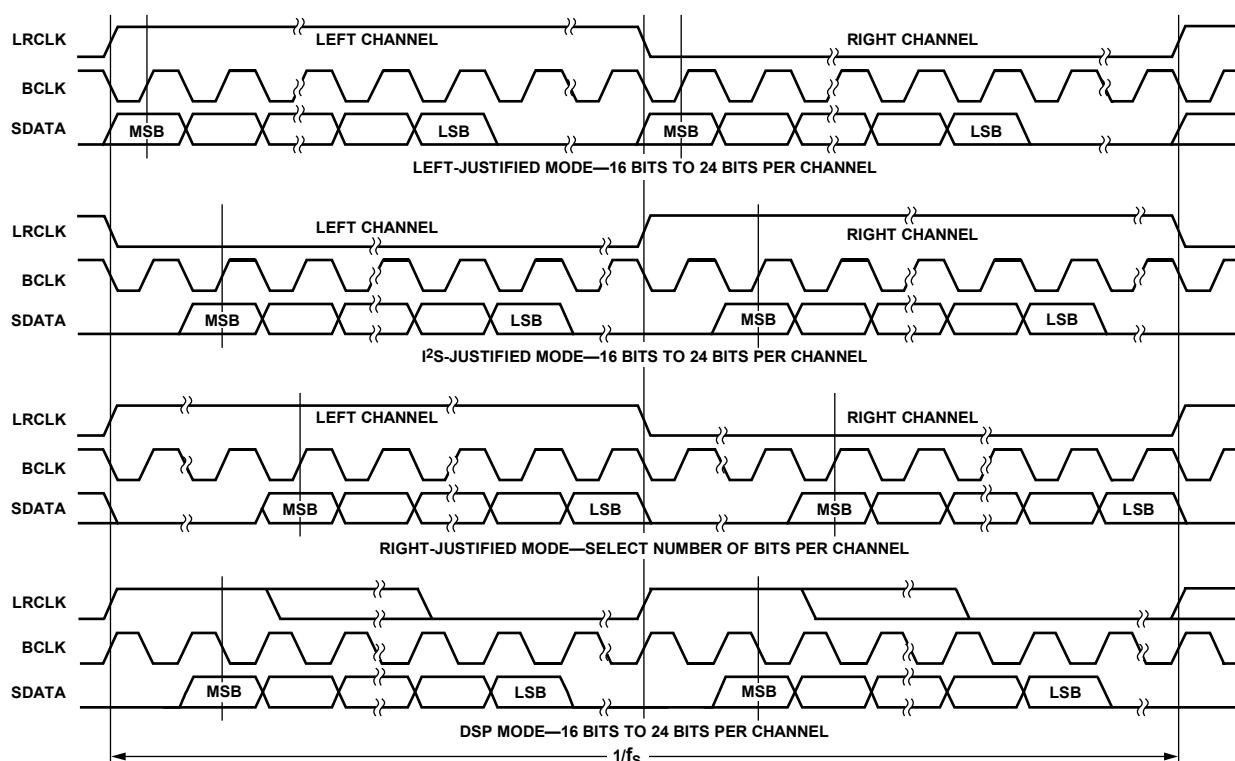

NOTES

1. DSP MODE DOES NOT IDENTIFY CHANNEL.
2. LRCLK NORMALLY OPERATES AT f_s EXCEPT FOR DSP MODE, WHICH IS $2 \times f_s$.
3. BCLK FREQUENCY IS NORMALLY $64 \times$ LRCLK BUT MAY BE OPERATED IN BURST MODE.

Figure 15. Stereo Modes

07414-024

TIME-DIVISION MULTIPLEXED (TDM) MODES

The serial ports of the AD1937 have several different TDM serial data modes. Single-line TDM mode is the most commonly used configuration (see Figure 16 and Figure 17).

These figures show 8-channel configuration; other possible options are 4- and 16-channel configurations. In Figure 16, the eight on-chip DAC data slots are packed into one I²S TDM stream. In this mode, both DBCLK and ABCLK are 256 fs. In Figure 17, the ADC serial port outputs one data stream consisting of four on-chip ADCs followed by four unused slots.

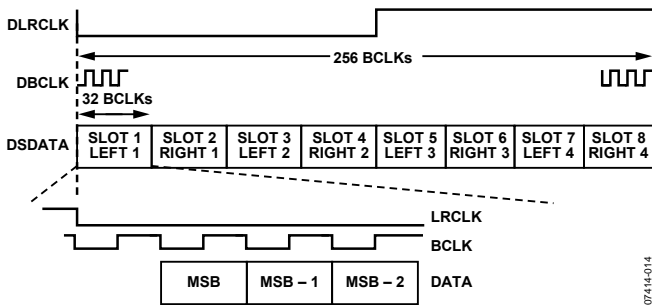

Figure 16. Single-Line TDM Mode 8-Channel DAC Configuration

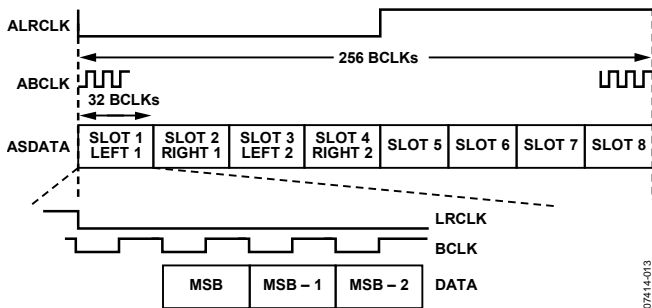

Figure 17. Single-Line TDM Mode 8-Channel ADC Configuration

The I/O pin functions of the serial ports are defined according to the serial mode that is selected. For a detailed description of the function of each pin in TDM and TDM/AUX modes, see Table 18.

The AD1937 allows systems with more than eight DAC channels to be easily configured by the use of an auxiliary serial data port. The TDM/AUX mode 16-channel configuration is shown in Figure 18. In this mode, the AUX channels are the last four slots of the TDM data stream. These slots are extracted and output to the AUX serial port. It should be noted that due to the high DBCLK frequency, this mode is available only in the 48 kHz/44.1 kHz/32 kHz sample rates. An 8-channel DAC configuration cannot be TDM/AUX because there are no extra data slots for the AUX packets; this would be single-line TDM mode.

The AD1937 also allows system configurations with more than four ADC channels as shown in Figure 19 (using 8 ADCs) and Figure 20 (using 16 ADCs). Due to the high ABCLK frequency, this mode is available only in the 48 kHz/44.1 kHz/32 kHz sample rates.

Combining the TDM/AUX ADC and DAC modes results in a system configuration of 8 ADCs and 12 DACs. The system, then consists of two external stereo ADCs, two external stereo DACs, and one AD1937. This mode is shown in Figure 21 (combined TDM/AUX DAC and ADC modes).

In the TDM/AUX mode, the frame sync (ALRLCK) triggers the TDM word by crossing the high frequency TDM BCLK (ABCLK) to 0, similar to the single-line TDM modes (see Figure 16 and Figure 17). The AUX LRCLK (DLRLCK) runs at the much slower fs of the AUX port; the AUX BCLK (DBCLK) runs at 64 × fs. This is shown in the TDM/AUX figures (see Figure 18 to Figure 21).

Table 18. Pin Function Changes in TDM and TDM/AUX Modes

Mnemonic	Stereo Modes	TDM Modes	TDM/AUX Modes
ASDATA1	ADC1 data out	TDM ADC data out	TDM data out
ASDATA2	ADC2 data out	TDM ADC data in	AUX DAC1 data out (to external DAC1)
DSDATA1	DAC1 data in	TDM DAC data in	TDM data in
DSDATA2	DAC2 data in	TDM DAC data out	AUX ADC1 data in (from external ADC1)
DSDATA3	DAC3 data in	TDM DAC2 data in (dual-line mode)	AUX ADC2 data in (from external ADC2)
DSDATA4	DAC4 data in	TDM DAC2 data out (dual-line mode)	AUX DAC2 data out (to external DAC2)
ALRLCK	ADC LRCLK in/out	TDM ADC frame sync in/out	TDM frame sync in/out
ABCLK	ADC BCLK in/out	TDM ADC BCLK in/out	TDM BCLK in/out
DLRLCK	DAC LRCLK in/out	TDM DAC frame sync in/out	AUX LRCLK in/out
DBCLK	DAC BCLK in/out	TDM DAC BCLK in/out	AUX BCLK in/out

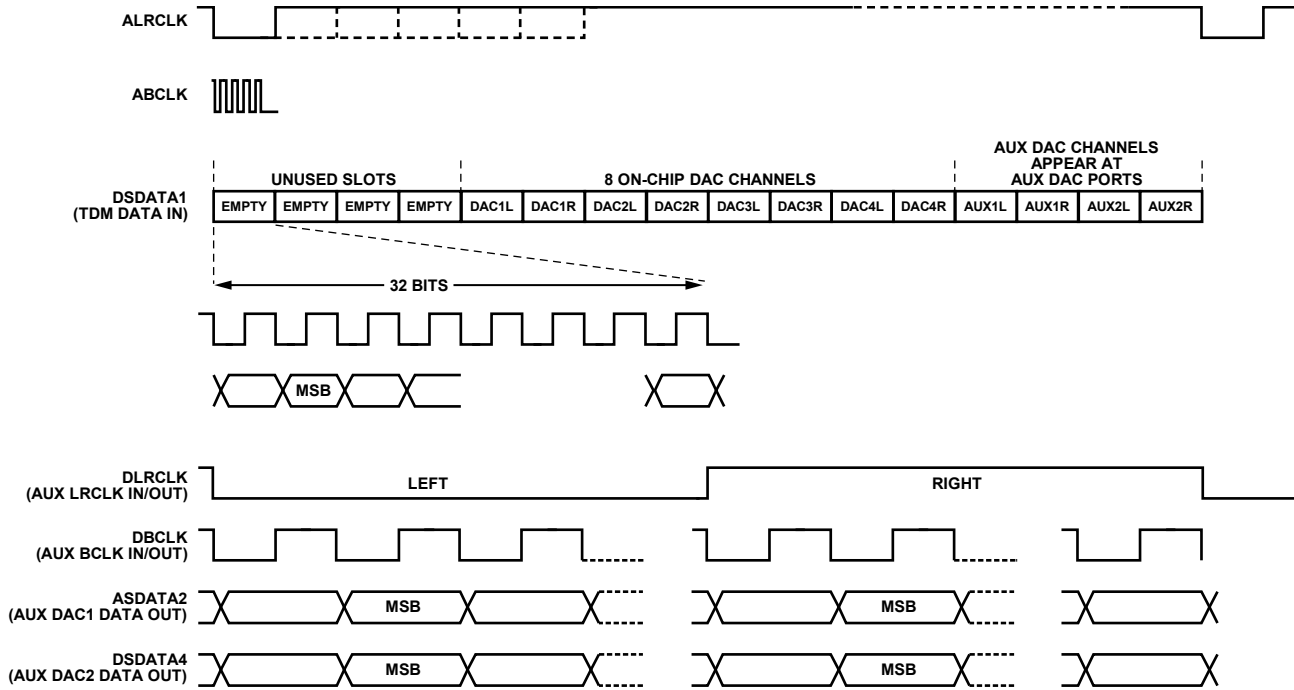

Figure 18. TDM/AUX Mode 16-Channel DAC configuration

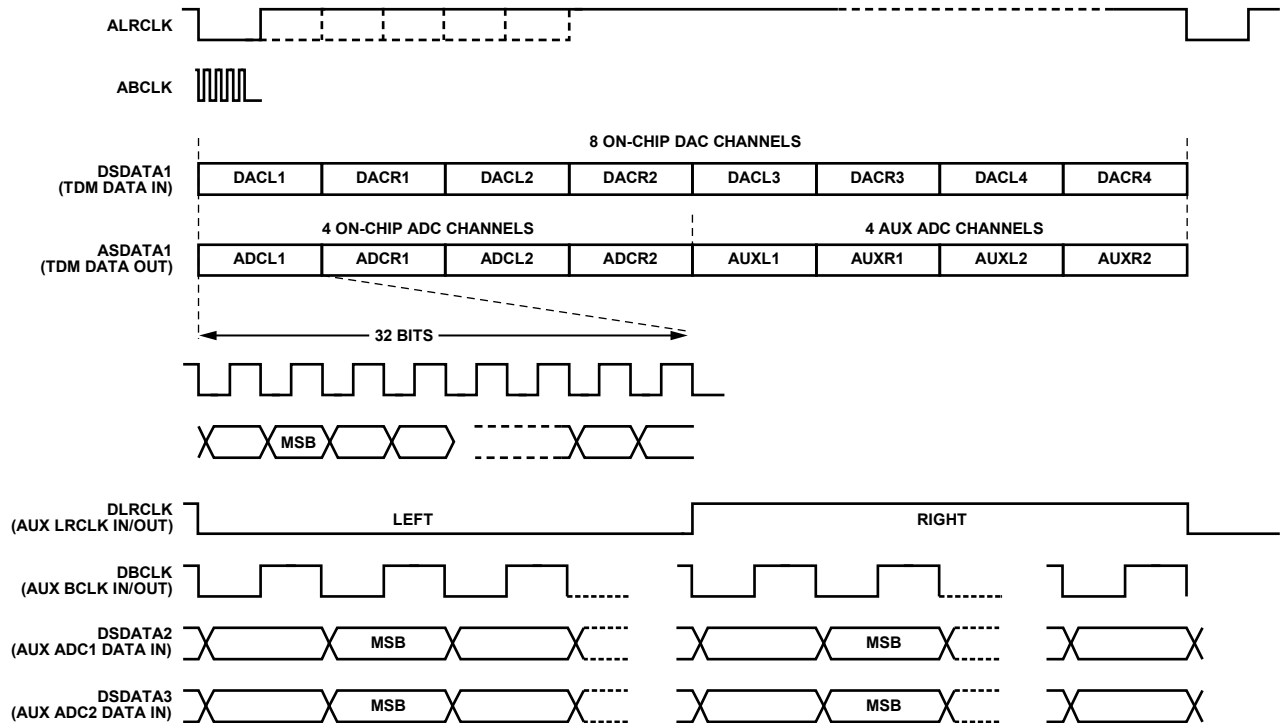

Figure 19. TDM/AUX Mode 8-Channel ADC Configuration

07414-015

07414-016

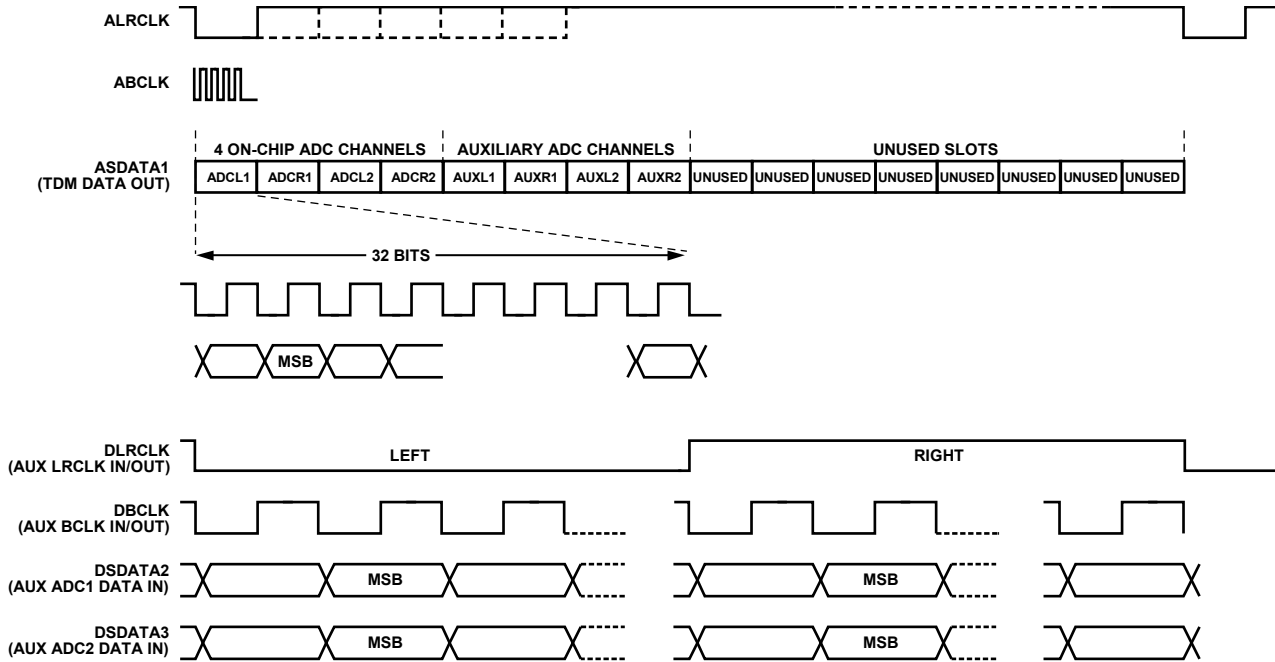

Figure 20. TDM/AUX Mode 16-Channel ADC Configuration

07414-017

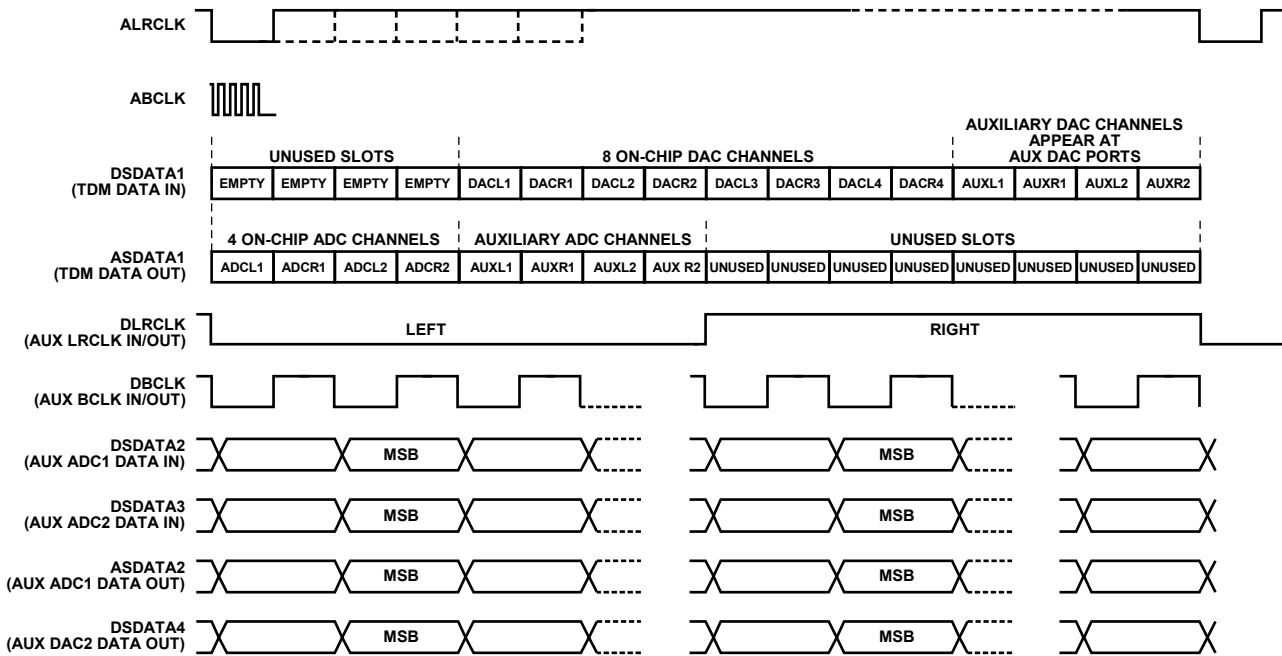

Figure 21. Combined TDM/AUX Mode DAC and ADC Configuration

07414-018

DAISY-CHAIN MODE

The AD1937 also allows a daisy-chain configuration to expand the system to 16 DACs and 8 ADCs (see Figure 22 to Figure 26). In this mode, the DBCLK frequency is $512 \times f_s$. The first eight slots of the TDM DAC data stream belong to the first AD1937 in the chain and the last eight slots belong to the second AD1937. The second AD1937 is the device attached to the DSP TDM port.

To accommodate 16 channels at a 96 kHz sample rate, the AD1937 can be configured into a dual-line, TDM mode as shown in Figure 23. This mode allows a slower DBCLK than normally required by the one-line TDM mode. The first four channels of each TDM input belong to the first AD1937 in the chain and the last four channels belong to the second AD1937.

The dual-line TDM mode can also be used to send data at a 192 kHz sample rate into the AD1937, as shown in Figure 24.

There are two configurations for the ADC port to work in daisy-chain mode. The first configuration is with an ABCLK at $256 \times f_s$, see Figure 25. The second configuration is with an ABCLK at $512 \times f_s$, see Figure 26. Note that in the $512 \times f_s$ ABCLK mode, the ADC channels occupy the first eight slots; the second eight slots are empty. The TDM ADC data in (ASDATA2) port of the first AD1937 must be grounded in all modes of operation.

The I/O pins of the serial ports are defined according to the serial mode selected. See Table 19 for a detailed description of the function of each pin. See Figure 27 for a typical AD1937 configuration with two external stereo DACs and two external stereo ADCs.

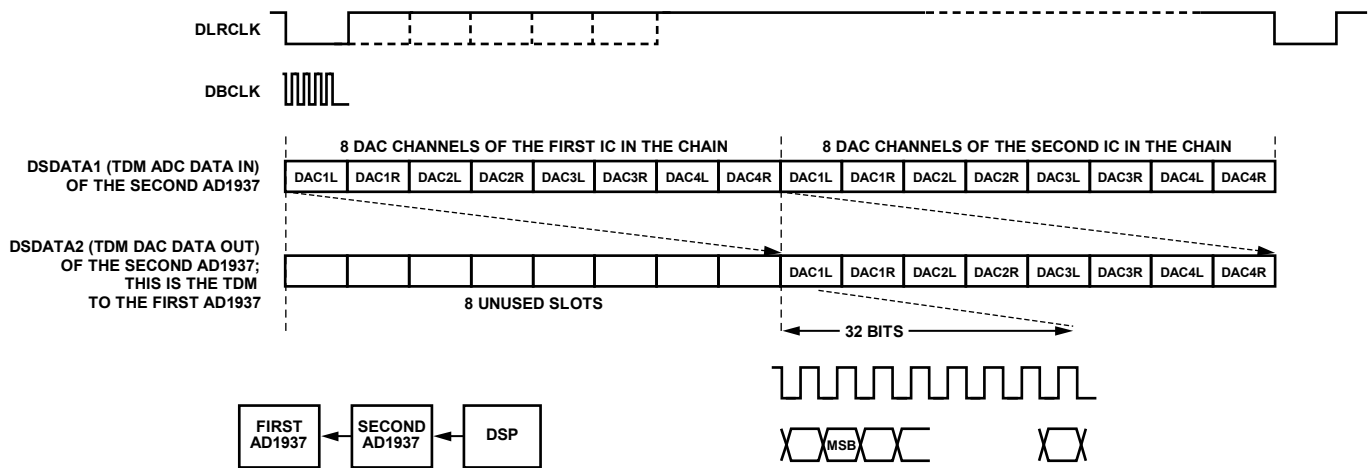

Figure 22. Single-Line Daisy-Chain TDM Mode 16-Channel 48 kHz DAC Configuration

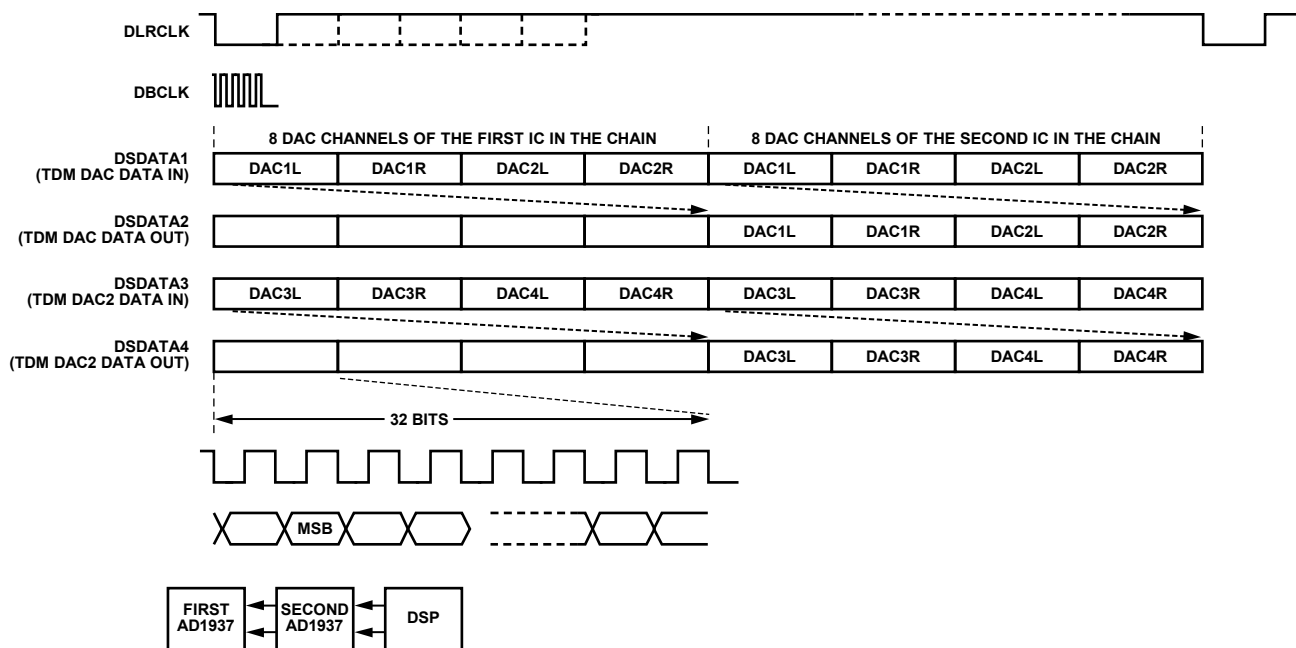

Figure 23. Dual-Line Daisy-Chain TDM Mode 16-Channel 96 kHz DAC Configuration

AD1937

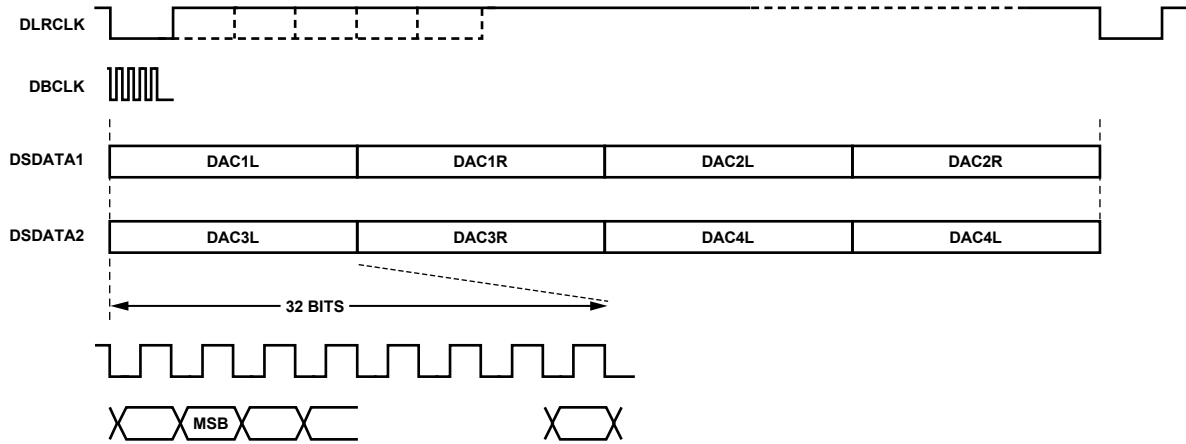

Figure 24. Dual-Line Daisy-Chain TDM Mode 8-Channel 192 kHz DAC Configuration

07414-021

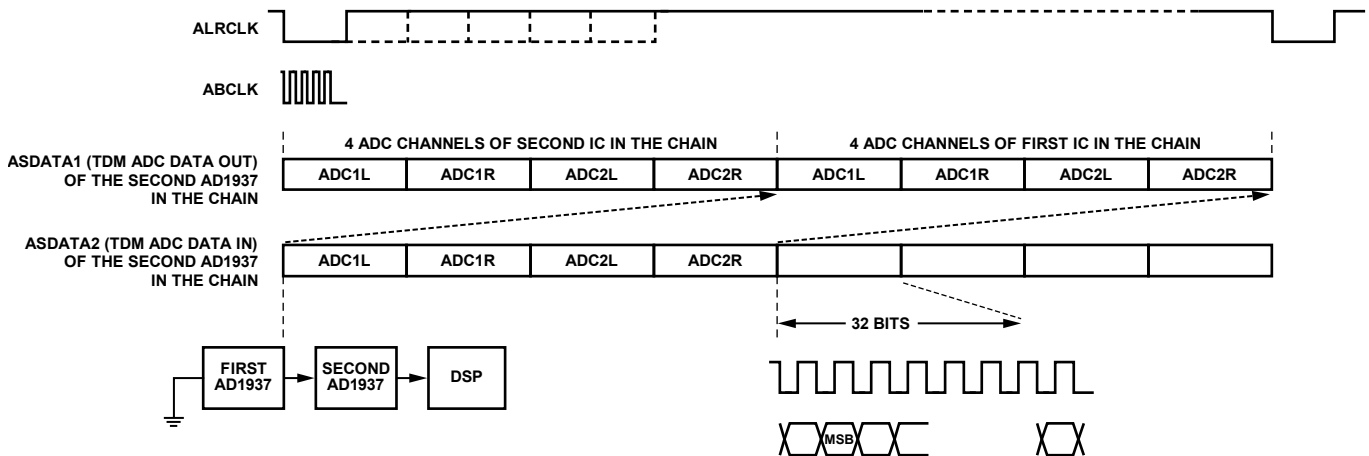

Figure 25. Single-Line Daisy-Chain TDM Mode $256 \times f_s$ ADC Configuration

07414-022

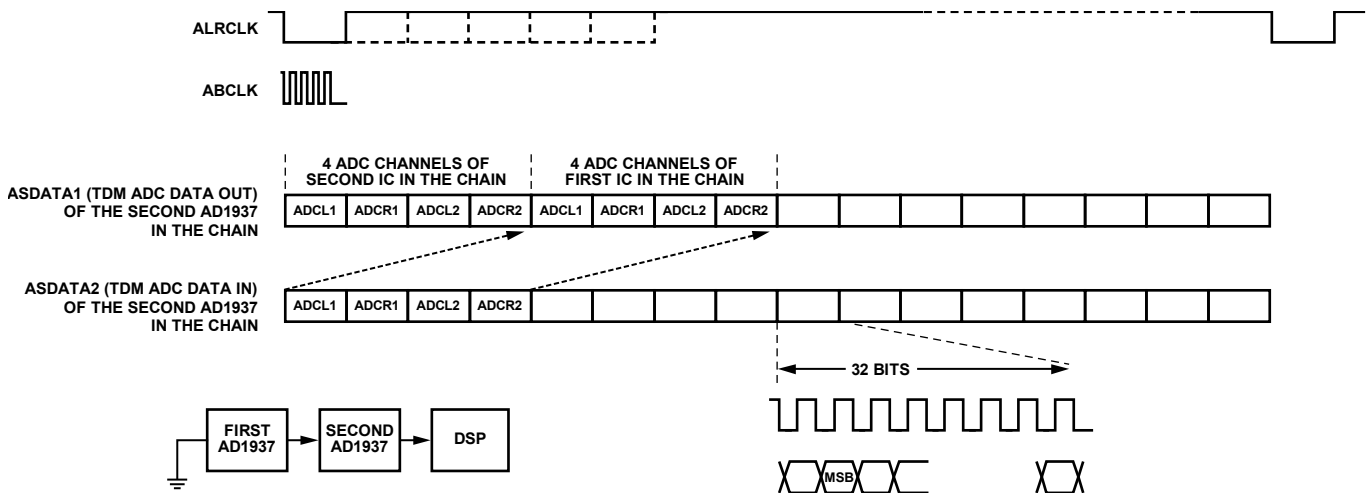

Figure 26. Single-Line Daisy-Chain TDM Mode $512 \times f_s$ ADC Configuration

07414-023

Table 19. Pin Function Changes in TDM and TDM/AUX Modes (Replication of Table 18)

Mnemonic	Stereo Modes	TDM Modes	TDM/AUX Modes
ASDATA1	ADC1 data out	TDM ADC data out	TDM data out
ASDATA2	ADC2 data out	TDM ADC data in	AUX DAC1 data out (to external DAC1)
DSDATA1	DAC1 data in	TDM DAC data in	TDM data in
DSDATA2	DAC2 data in	TDM DAC data out	AUX ADC1 data in (from external ADC1)
DSDATA3	DAC3 data in	TDM DAC2 data in (dual-line mode)	AUX ADC2 data in (from external ADC2)
DSDATA4	DAC4 data in	TDM DAC2 data out (dual-line mode)	AUX DAC2 data out (to external DAC2)
ALRCLK	ADC LRCLK in/out	TDM ADC frame sync in/out	TDM frame sync in/out
ABCLK	ADC BCLK in/out	TDM ADC BCLK in/out	TDM BCLK in/out
DLRCLK	DAC LRCLK in/out	TDM DAC frame sync in/out	AUX LRCLK in/out
DBCLK	DAC BCLK in/out	TDM DAC BCLK in/out	AUX BCLK in/out

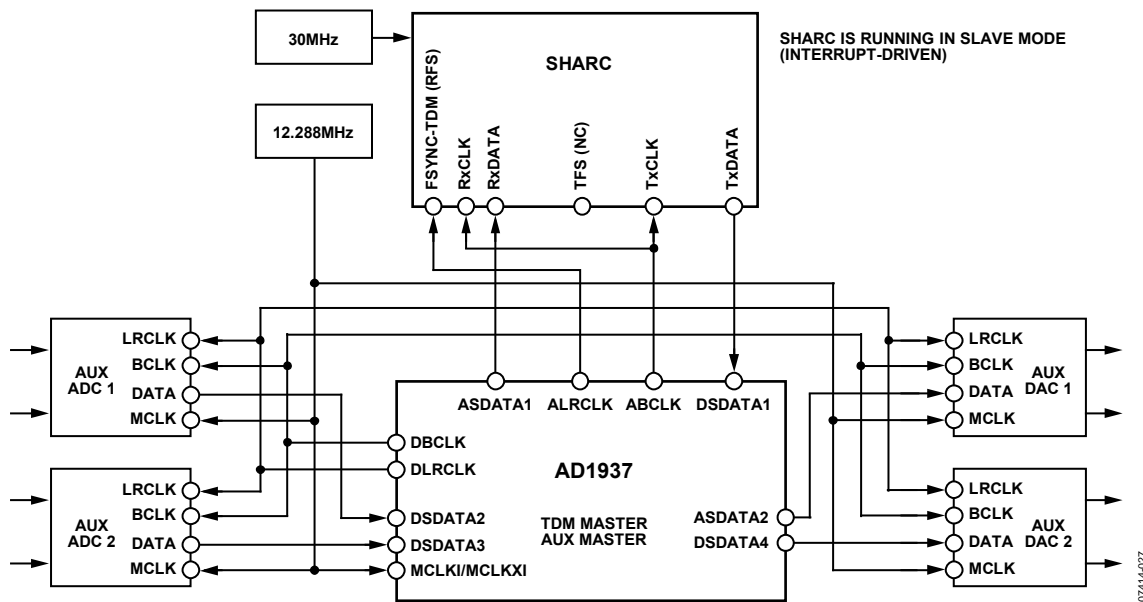

Figure 27. Example of TDM/AUX Mode Connection to SHARC® (AD1937 as TDM Master/AUX Master Shown)

ADDITIONAL MODES

The AD1937 offers several additional modes for board level design enhancements. To reduce the EMI in board level design, serial data can be transmitted without an explicit BCLK. See Figure 28 and Figure 29 for an example of a DAC TDM data transmission mode that does not require high speed DBCLK. This configuration is applicable when the AD1937 master clock is generated by the PLL with the DLRCLK as the PLL reference frequency.

To relax the requirement for the setup time of the AD1937 in cases of high speed TDM data transmission, the AD1937 can latch in the data using the falling edge of DBCLK. This effectively dedicates the entire BCLK period to the setup time. This mode is useful in cases where the source has a large delay time in the serial data driver. Figure 30 shows this pipeline mode of data transmission.

Both the BCLK-less and pipeline modes are available on the ADC serial data port.

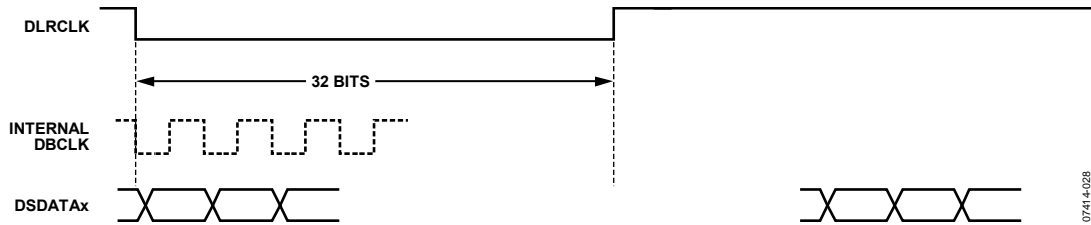

Figure 28. Serial DAC Data Transmission in TDM Format Without DBCLK; 2-Channel 64 BCLKs per Frame Mode
(Applicable Only If PLL Locks to DLRCLK; This Mode Is Also Available in the ADC Serial Data Port)

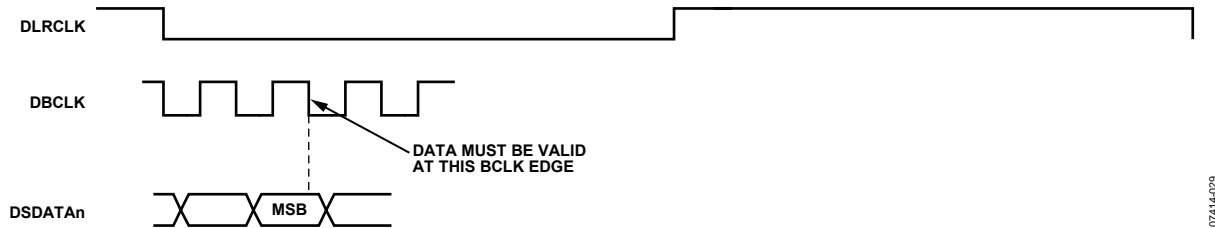

Figure 29. Serial DAC Data Transmission in TDM Format Without DBCLK; 128 to 512 BCLKs per Frame TDM Mode
(Applicable Only If PLL Locks to DLRCLK; This Mode Is Also Available in the ADC Serial Data Port)

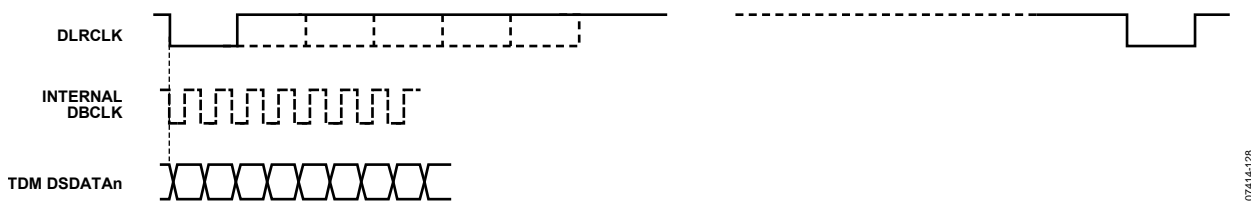

Figure 30. I²S Pipeline Mode in DAC Serial Data Transmission
(Applicable in Stereo and TDM, Useful for High Frequency TDM Transmission;
This Mode Is Also Available in the ADC Serial Data Port)

CONTROL REGISTERS

DEFINITIONS

The global address for the AD1937 is 0x08 OR'ed with ADDR1 and ADDR0 and one R/W bit; see Figure 13 and Figure 14. The address bits (Bits[18:17]) setting must correspond to the low/high state of Pin 30 and Pin 35. All registers are reset to 0, except for the DAC volume registers that are set to full volume.

Note that the first setting in each control register parameter is the default setting.

Table 20. Register Format

	Global Address	R/W	Register Address	Data
Bit	23:17	16	15:8	7:0

Table 21. Register Addresses and Functions

Hexadecimal	Address	Function
0x00	0	PLL and Clock Control 0
0x01	1	PLL and Clock Control 1
0x02	2	DAC Control 0
0x03	3	DAC Control 1
0x04	4	DAC Control 2
0x05	5	DAC individual channel mutes
0x06	6	DAC1L volume control
0x07	7	DAC1R volume control
0x08	8	DAC2L volume control
0x09	9	DAC2R volume control
0x0A	10	DAC3L volume control
0x0B	11	DAC3R volume control
0x0C	12	DAC4L volume control
0x0D	13	DAC4R volume control
0x0E	14	ADC Control 0
0x0F	15	ADC Control 1
0x10	16	ADC Control 2

PLL AND CLOCK CONTROL REGISTERS

Table 22. PLL and Clock Control 0 Register (Address 0, 0x00)

Bit	Value	Function	Description
0	0	Normal operation	PLL power-down
	1	Power-down	
2:1	00	Input 256 (× 44.1 kHz or 48 kHz)	MCLKI/MCLKXI pin functionality (PLL active), master clock rate setting
	01	Input 384 (× 44.1 kHz or 48 kHz)	
	10	Input 512 (× 44.1 kHz or 48 kHz)	
	11	Input 768 (× 44.1 kHz or 48 kHz)	
4:3	00	XTAL oscillator enabled	MCLKO/MCLKXO pin, master clock rate setting
	01	256 × f _s VCO output	
	10	512 × f _s VCO output	
	11	Off	
6:5	00	MCLKI/MCLKXI	PLL input
	01	DLRCLK	
	10	ALRCLK	
	11	Reserved	
7	0	Disable: ADC and DAC idle	Internal master clock enable
	1	Enable: ADC and DAC active	

AD1937

Table 23. PLL and Clock Control 1 Register (Address 1, 0x01)

Bit	Value	Function	Description
0	0	PLL clock	DAC clock source select
	1	MCLK	
1	0	PLL clock	ADC clock source select
	1	MCLK	
2	0	Enabled	On-chip voltage reference
	1	Disabled	
3	0	Not locked	PLL lock indicator (read-only)
	1	Locked	
7:4	0000	Reserved	

DAC CONTROL REGISTERS

Table 24. DAC Control 0 Register (Address 2, 0x02)

Bit	Value	Function	Description
0	0	Normal	Power-down
	1	Power-down	
2:1	00	32 kHz/44.1 kHz/48 kHz	Sample rate
	01	64 kHz/88.2 kHz/96 kHz	
	10	128 kHz/176.4 kHz/192 kHz	
	11	Reserved	
5:3	000	1 cycle (I ² S mode)	DSDATA delay (BCLK periods)
	001	0 (left-justified mode)	
	010	8 cycles (right-justified 24-bit mode)	
	011	12 cycles (right-justified 20-bit mode)	
	100	16 cycles (right-justified 16-bit mode)	
	101	Reserved	
	110	Reserved	
111	Reserved		
7:6	00	Stereo (normal)	Serial format
	01	TDM single-line, standalone, and daisy-chain modes	
	10	TDM/AUX mode (ADC-, DAC-, TDM-coupled)	
	11	TDM dual-line daisy-chain mode	

Table 25. DAC Control 1 Register (Address 3, 0x03)

Bit	Value	Function	Description
0	0	Latch in midcycle (normal)	DBCLK active edge (TDM_IN)
	1	Latch in at end of cycle (pipeline)	
2:1	00	64 (2 channels)	DBCLKs per frame
	01	128 (4 channels)	
	10	256 (8 channels)	
	11	512 (16 channels)	
3	0	Left low	DLRCLK polarity
	1	Left high	
4	0	Slave	DLRCLK master/slave
	1	Master	
5	0	Slave	DBCLK master/slave
	1	Master	
6	0	DBCLK pin	DBCLK source
	1	Internally generated	
7	0	Normal	DBCLK polarity
	1	Inverted	

Table 26. DAC Control 2 Register (Address 4, 0x04)

Bit	Value	Function	Description
0	0	Unmute	Master mute
	1	Mute	
2:1	00	Flat	De-emphasis (32 kHz/44.1 kHz/48 kHz mode only)
	01	48 kHz curve	
	10	44.1 kHz curve	
	11	32 kHz curve	
4:3	00	24 bits	Word width
	01	20 bits	
	10	Reserved	
	11	16 bits	
5	0	Noninverted	DAC output polarity
	1	Inverted	
7:6	00	Reserved	

Table 27. DAC Individual Channel Mutes Register (Address 5, 0x05)

Bit	Value	Function	Description
0	0	Unmute	DAC1L mute
	1	Mute	
1	0	Unmute	DAC1R mute
	1	Mute	
2	0	Unmute	DAC2L mute
	1	Mute	
3	0	Unmute	DAC2R mute
	1	Mute	
4	0	Unmute	DAC3L mute
	1	Mute	
5	0	Unmute	DAC3R mute
	1	Mute	
6	0	Unmute	DAC4L mute
	1	Mute	
7	0	Unmute	DAC4R mute
	1	Mute	

AD1937

Table 28. DACxx Volume Controls Registers (Address 6 to Address 13, 0x06 to 0x0D)

Bit	Value	Function	Description
7:0	0	No attenuation	DAC volume control
	1 to 254	-0.375 dB per step	
	255	Full attenuation	

ADC CONTROL REGISTERS

Table 29. ADC Control 0 Register (Address 14, 0x0E)

Bit	Value	Function	Description
0	0	Normal	Power-down
	1	Power down	
1	0	Off	High-pass filter
	1	On	
2	0	Unmute	ADC1L mute
	1	Mute	
3	0	Unmute	ADC1R mute
	1	Mute	
4	0	Unmute	ADC2L mute
	1	Mute	
5	0	Unmute	ADC2R mute
	1	Mute	
7:6	00	32 kHz/44.1 kHz/48 kHz	Output sample rate
	01	64 kHz/88.2 kHz/96 kHz	
	10	128 kHz/176.4 kHz/192 kHz	
	11	Reserved	

Table 30. ADC Control 1 Register (Address 15, 0x0F)

Bit	Value	Function	Description
1:0	00	24 bits	Word width
	01	20 bits	
	10	Reserved	
	11	16 bits	
4:2	000	1 cycle (I ² S mode)	ASDATA delay (BCLK periods)
	001	0 (left-justified mode)	
	010	8 cycles (right-justified 24-bit mode)	
	011	12 cycles (right-justified 20-bit mode)	
	100	16 cycles (right-justified 16-bit mode)	
	101	Reserved	
	110	Reserved	
111	Reserved		
6:5	00	Stereo	Serial format
	01	TDM single-line, standalone, and daisy-chain modes	
	10	TDM/AUX mode (ADC-, DAC-, TDM-coupled)	
	11	Reserved	
7	0	Latch in midcycle (normal)	ABCLK active edge (TDM_IN)
	1	Latch in at end of cycle (pipeline)	

Table 31. ADC Control 2 Register (Address 16, 0x10)

Bit	Value	Function	Description
0	0	50/50 (allows 32, 24, 20, or 16 BCLKs per channel)	ALRCLK format
	1	Pulse (32 BCLKs per channel)	
1	0	Drive out on falling edge (DEF)	ABCLK polarity
	1	Drive out on rising edge	
2	0	Left low	ALRCLK polarity
	1	Left high	
3	0	Slave	ALRCLK master/slave
	1	Master	
5:4	00	64 cycles	ABCLKs per frame
	01	128 cycles	
	10	256 cycles	
	11	512 cycles	
6	0	Slave	ABCLK master/slave
	1	Master	
7	0	ABCLK pin	ABCLK source
	1	Internally generated	

APPLICATIONS CIRCUITS

Typical application circuits are shown in Figure 31 through Figure 34. Figure 31 shows a typical ADC input filter circuit. Recommended loop filters for LRCLK and MCLK as the PLL reference are shown in Figure 32. Output filters for the DAC outputs are shown in Figure 33 and a regulator circuit is shown in Figure 34.

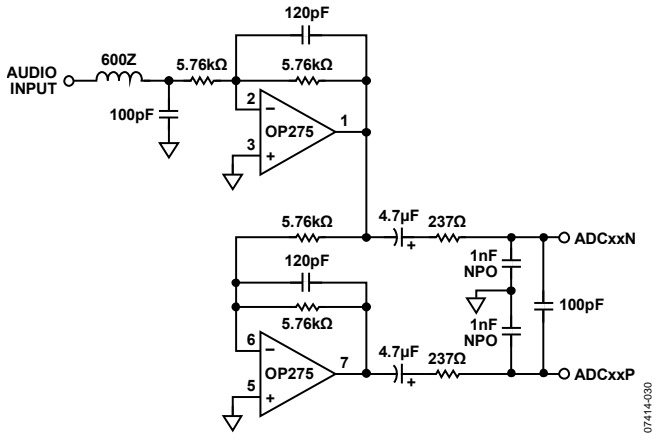

Figure 31. Typical ADC Input Filter Circuit

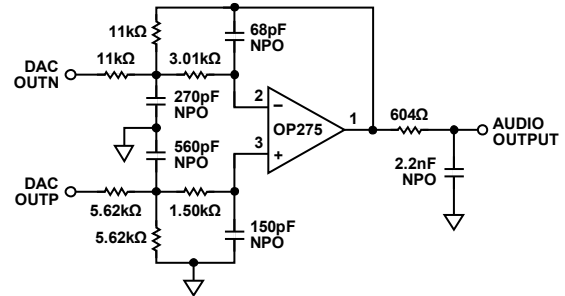

Figure 33. Typical DAC Output Filter Circuit (Differential)

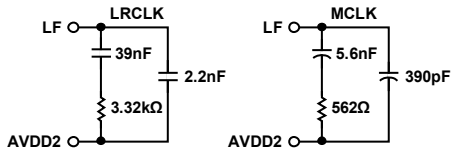

Figure 32. Recommended Loop Filters for LRCLK or MCLK as PLL Reference

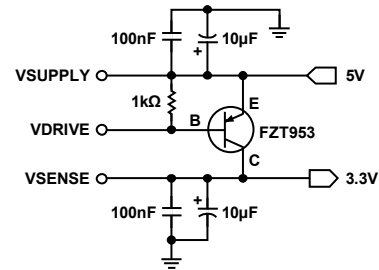
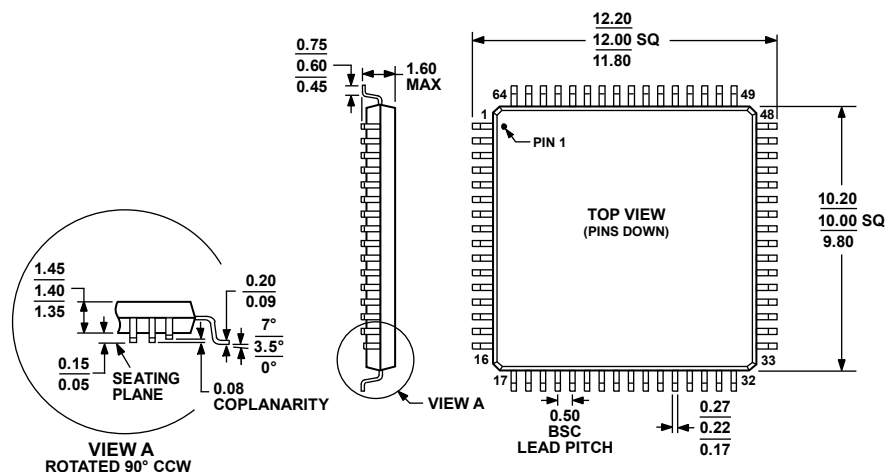

Figure 34. Recommended 3.3 V Regulator Circuit

OUTLINE DIMENSIONS



COMPLIANT TO JEDEC STANDARDS MS-026-BCD

Figure 35. 64-Lead Low Profile Quad Flat Package [LQFP]
(ST-64-2)

Dimensions shown in millimeters

ORDERING GUIDE

Model ^{1, 2}	Temperature Range	Package Description	Package Option
AD1937WBSTZ	-40°C to +125°C	64-Lead LQFP	ST-64-2
AD1937WBSTZ-RL	-40°C to +125°C	64-Lead LQFP, 13" Tape and Reel	ST-64-2
EVAL-AD1937AZ		Evaluation Board	

¹ Z = RoHS Compliant Part.

² W = Qualified for Automotive Applications.

AUTOMOTIVE PRODUCTS

The AD1937WBSTZ models are available with controlled manufacturing to support the quality and reliability requirements of automotive applications. Note that these automotive models may have specifications that differ from the commercial models; therefore, designers should review the Specifications section of this data sheet carefully. Only the automotive grade products shown are available for use in automotive applications. Contact your local Analog Devices account representative for specific product ordering information and to obtain the specific Automotive Reliability reports for these models.

AD1937

NOTES

NOTES

NOTES

I²C refers to a communications protocol originally developed by Philips Semiconductors (now NXP Semiconductors).

Looking for pricing, stock, or lifecycle information?

Click below to explore more details on WIN SOURCE:

 [View AD1937WBSTZ on WIN SOURCE](#)

 [Analog Devices Inc. Information](#)

Optimize Your Supply Chain with WIN SOURCE Solutions

-  Global Sourcing Solution
-  Obsolete Management
-  Cost Control Management
-  Shortage Management
-  Alternative Solution
-  Excess Inventory Management