



**THE DATASHEET OF
AD1888JST-REEL**



FEATURES

AC '97 2.3 compatible features
 6 DAC channels for 5.1 surround
 90 dB dynamic range
 20-bit PCM DACs
 S/PDIF output
 Integrated stereo headphone amplifiers
 Phone, aux, and line-in
 High quality CD input
 Selectable MIC input
 Mono output
 External amplifier power-down control
 Double rate audio ($f_s = 96$ kHz)
 Power-management modes
 48-lead LQFP and 48-lead LFCSP

ENHANCED FEATURES

Selectable front and rear MIC inputs with preamp
 Integrated PLL for system clocking
 Crystal-free operation
 Variable sample rate 7 kHz to 96 kHz
 Jack sense (auto topology switching)
 Software-controlled VREF_OUT for MIC bias
 Software enabled outputs for jack sharing
 Auto down-mix and channel spreading modes

FUNCTIONAL BLOCK DIAGRAM

Figure 1.

Rev. A

Information furnished by Analog Devices is believed to be accurate and reliable. However, no responsibility is assumed by Analog Devices for its use, nor for any infringements of patents or other rights of third parties that may result from its use. Specifications subject to change without notice. No license is granted by implication or otherwise under any patent or patent rights of Analog Devices. Trademarks and registered trademarks are the property of their respective owners.

TABLE OF CONTENTS

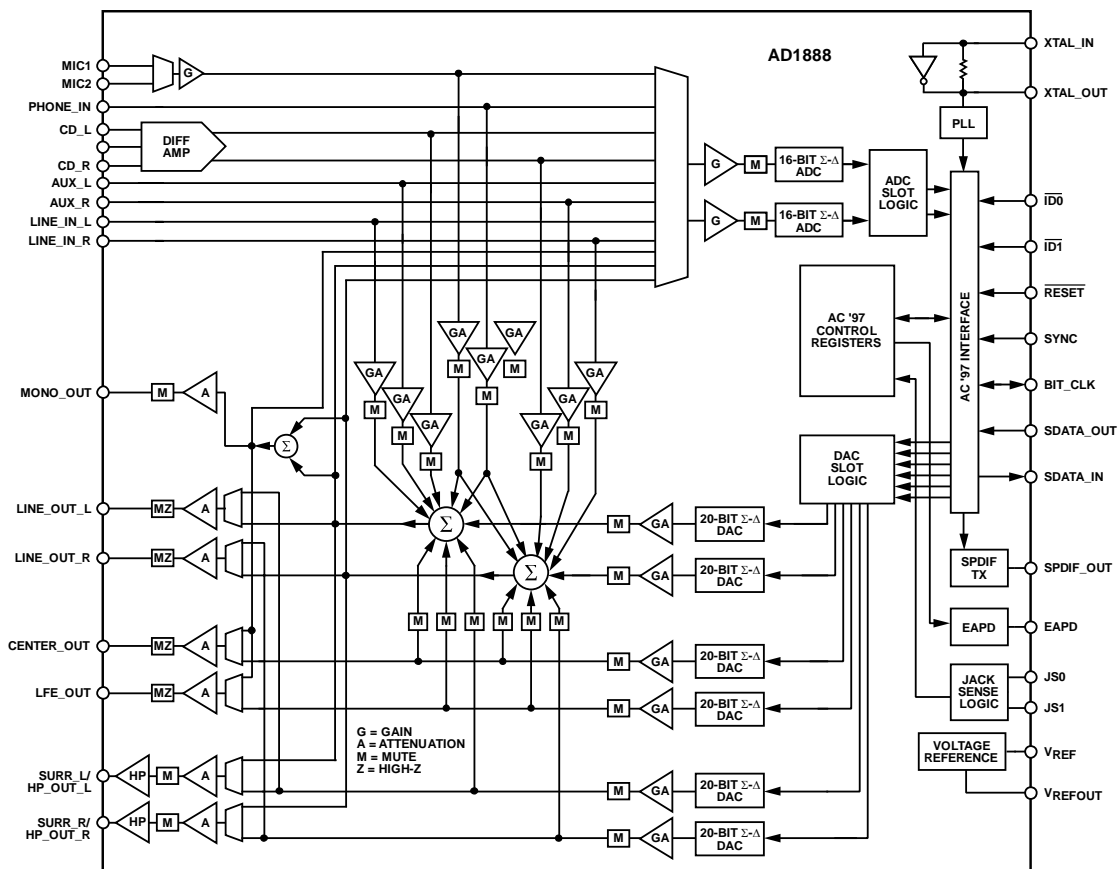
Specifications.....	3	Pin Configuration and Function Descriptions.....	9
Test Conditions.....	3	Outline Dimensions	31
Timing Parameters	6	Ordering Guide	31
Absolute Maximum Ratings.....	8		
Environmental Conditions.....	8		
ESD Caution.....	8		

REVISION HISTORY

8/05—Rev. 0 to Rev. A

Updated Outline Dimensions	31
Changes to Ordering Guide	31

10/03—Revision 0: Initial Version

SPECIFICATIONS

TEST CONDITIONS

Standard Test Conditions

Unless otherwise noted:

- Temperature 25°C
- Digital Supply (DVDD) 3.3 V
- Analog Supply (AVDD) 5.0 V
- Sample Rate (f_s) 48 kHz
- Input Signal 1 kHz
- Analog Output Pass Band 20 Hz to 20 kHz

DAC Test Conditions

- Calibrated
- –3 dB attenuation relative to full scale
- 0 dB input
- 10 k Ω output load LINE_OUT, MONO_OUT, CENTER_OUT, and LFE_OUT
- 32 Ω output load (HP_OUT)

ADC Test Conditions

- Calibrated
- 0 dB gain
- Input –3.0 dB relative to full scale

Table 1.

Parameter	Min	Typ	Max	Unit
ANALOG INPUT				
Input Voltage (RMS Values Assume Sine Wave Input) LINE_IN, CD, AUX, PHONE_IN		1 2.83		V rms V p-p
MIC_IN with 30 dB Preamp		0.032 0.089		V rms V p-p
MIC_IN with 20 dB Preamp		0.1 0.283		V rms V p-p
MIC_IN with 10 dB Preamp		0.316 0.894		V rms V p-p
MIC_IN with 0 dB Gain		1 2.83		V rms V p-p
Input Impedance ¹		20		K Ω
Input Capacitance ¹		5	7.5	pF
MASTER VOLUME				
Step Size (Line Out, Mono Out, Surround Out, Center, LFE)		1.5		dB
Output Attenuation Range Span ¹		46.5		dB
Mute Attenuation of 0 dB Fundamental ¹			80	dB
PROGRAMMABLE GAIN AMPLIFIER—ADC				
Step Size (0 dB to 22.5 dB)		1.5		dB
PGA Gain Range Span		22.5		dB
ANALOG MIXER—INPUT GAIN/AMPLIFIERS/ATTENUATORS				
Signal-to-Noise Ratio (SNR) CD to LINE_OUT		90		dB
LINE, AUX, or PHONE to LINE_OUT ¹		90		dB
MIC1 or MIC2 (Note: MIC Gain of 0 dB) to LINE_OUT ¹		90		dB
Step Size All Mixer Inputs		1.5		dB
Input Gain/Attenuation Range: All Mixer Inputs		46.5		dB
DIGITAL DECIMATION AND INTERPOLATION FILTERS¹				
Pass Band	0		$0.4 \times f_s$	Hz
Pass-Band Ripple			± 0.09	dB
Transition Band	$0.4 \times f_s$		$0.6 \times f_s$	Hz
Stop Band	$0.6 \times f_s$		∞	Hz
Stop-Band Rejection	–74			dB
Group Delay		$16/f_s$		sec
Group Delay Variation over Pass Band		0		μ s

AD1888

Parameter	Min	Typ	Max	Unit
ANALOG-TO-DIGITAL CONVERTERS				
Resolution		16		Bits
Total Harmonic Distortion (THD) $AV_{DD} = 5.0\text{ V}$		-78		dB
Dynamic Range (-60 dB Input THD + N Referenced to FS, A-Weighted) $AV_{DD} = 5.0\text{ V}$		80		dB
Signal-to-Intermodulation Distortion ¹ (CCIF Method)		84		dB
ADC Crosstalk ¹				
Line Inputs (Input L, Ground R, Read R; Input R, Ground L, Read L)		-85		dB
LINE_IN to Other		-85		dB
Gain Error (Full-Scale Span Relative to Nominal Input Voltage)		±10		%
Interchannel Gain Mismatch (Difference of Gain Errors)		±0.5		dB
ADC Offset Error ¹ (0 dB Gain, HPF On)		±10		mV
DIGITAL-TO-ANALOG CONVERTERS				
Resolution		20		Bits
Total Harmonic Distortion (THD), LINE_OUT, $AV_{DD} = 5.0\text{ V}$		-80		dB
Total Harmonic Distortion (THD), HP_OUT, $AV_{DD} = 5.0\text{ V}$		-70		dB
Total Harmonic Distortion (THD), CENTER/LFE, $AV_{DD} = 5.0\text{ V}$		-80		dB
Dynamic Range (-60 dB Input THD + N Referenced to FS A-Weighted) $AV_{DD} = 5.0\text{ V}$, All Outputs		90		dB
Signal-to-Intermodulation Distortion ¹ (CCIF Method)		88		dB
Gain Error (Full-Scale Span Relative to Nominal Input Voltage)		±10		%
Interchannel Gain Mismatch (Difference of Gain Errors)		±0.7		dB
DAC Crosstalk (Input L, Zero R, Read LINE_OUT_R; Input R, Zero L, Read LINE_OUT_L, 10 kΩ Load) ¹		-80		dB
Total Audible Out-of-Band Energy ¹ (Measured from $0.6 \times f_s$ to 20 kHz)		-40		dB
ANALOG OUTPUT				
Full-Scale Output Voltage; LINE_OUT/MONO_OUT, CENTER_OUT, LFE_OUT		1		V rms
		2.83		V p-p
Output Impedance ¹		300		Ω
External Load Impedance ¹ (LINE_OUT, CENTER_OUT/LFE_OUT, MONO_OUT)	10			kΩ
Output Capacitance ¹		15		pF
External Load Capacitance ¹			100	pF
Full-Scale Output Voltage; HP_OUT (0 dB Gain)		1		V rms
External Load Impedance ¹ ; HP_OUT	32			Ω
V_{REF}	2.05	2.25	2.45	V
V_{REF_OUT} ($V_{REFH} = 0$)		2.25		V
V_{REF_OUT} ($V_{REFH} = 1$)		3.65		V
V_{REF_OUT} Current Drive			5	mA
Mute Click (Muted Output Minus Unmuted Midscale DAC Output)		±5		mV
STATIC DIGITAL SPECIFICATIONS				
High Level Input Voltage (V_{IH}): Digital Inputs	$0.65 \times DV_{DD}$			V
Low Level Input Voltage (V_{IL})			$0.35 \times DV_{DD}$	V
High Level Output Voltage (V_{OH}), $I_{OH} = 2\text{ mA}$	$0.9 \times DV_{DD}$			V
Low Level Output Voltage (V_{OL}), $I_{OL} = 2\text{ mA}$			$0.1 \times DV_{DD}$	V
Input Leakage Current	-10		+10	μA
Output Leakage Current	-10		+10	μA

Parameter	Min	Typ	Max	Unit
POWER SUPPLY				
Power Supply Range, Analog (AV _{DD})	4.75		5.25	V
Power Supply Range, Digital (DV _{DD})	3.15		3.45	V
Power Dissipation 5 V/3.3 V		563		mW
Analog Supply Current 5 V (AV _{DD})		70		mA
Digital Supply Current 3.3 V (DV _{DD})		53		mA
Power Supply Rejection (100 mV p-p Signal @ 1 kHz) ¹ (At Both Analog and Digital Supply Pins, Both ADCs and DACs)		-40		dB

¹ Guaranteed but not tested.

Parameter	PR[K:I] ¹	PR[6:0] ¹	DV _{DD} Typ	AV _{DD} Typ	Unit
POWER-DOWN STATES²					
Fully Active	000	000 0000	53	70	mA
ADC	000	000 0001	44	66	mA
FRONT DAC	000	000 0010	46	61	mA
SURROUND DAC	010	000 0000	46	61	mA
CENTER/LFE DAC	101	000 0000	46	61	mA
ADC + ALL DACs	111	000 0011	12	33	mA
Mixer	000	000 0100	52	44	mA
ADC + Mixer	000	000 0101	45	39	mA
ALL DACs + Mixer	111	000 0110	31	14	mA
ADC + ALL DACs + Mixer	111	000 0111	12	8	mA
Standby	111	011 1111	0	0	mA
Headphone Standby	000	100 0000	52	65	mA

¹ PR bits are controlled in Reg. 2Ah and 26h.

² Values presented with V_{REFOUT} loaded.

Parameter	Min	Typ	Max	Unit
CLOCK SPECIFICATIONS¹				
Input Clock Frequency (XTAL Mode or Clock Oscillator)		24.576		MHz
Input Clock Frequency (Reference Clock Mode)		14.31818		MHz
Input Clock Frequency (USB Clock Mode)		48.000		MHz
Recommended Clock Duty Cycle	40	50	60	%

¹ Guaranteed but not tested.

TIMING PARAMETERS

Guaranteed over operating temperature range.

Table 2.

Parameter	Symbol	Min	Typ	Max	Unit
RESET Active Low Pulse Width	t_{RST_LOW}		1.0		μs
RESET Inactive to BIT_CLK Startup Delay	$t_{RST2CLK}$	162.8		400,000	ns
SYNC Active High Pulse Width	t_{SYNC_HIGH}		1.3		μs
SYNC Low Pulse Width	t_{SYNC_LOW}		19.5		μs
SYNC Inactive to BIT_CLK Startup Delay	$t_{SYNC2CLK}$	162.8			ns
BIT_CLK Frequency			12.288		MHz
BIT_CLK Frequency Accuracy				± 1.0	ppm
BIT_CLK Period	t_{CLK_PERIOD}		81.4		ns
BIT_CLK Output Jitter ^{1, 2}			750		ps
BIT_CLK High Pulse Width	t_{CLK_HIGH}	40		41.7	ns
BIT_CLK Low Pulse Width	t_{CLK_LOW}	39.7		41.4	ns
SYNC Frequency			48.0		kHz
SYNC Period	t_{SYNC_PERIOD}		20.8		μs
Setup to Falling Edge of BIT_CLK	t_{SETUP}	4			ns
Hold from Falling Edge of BIT_CLK	t_{HOLD}	3			ns
BIT_CLK Rise Time	$t_{RISECLK}$	2	4	6	ns
BIT_CLK Fall Time	$t_{FALLCLK}$	2	4	6	ns
SYNC Rise Time	$t_{RISESYNC}$	2	4	6	ns
SYNC Fall Time	$t_{FALLSYNC}$	2	4	6	ns
SDATA_IN Rise Time	$t_{RISEDIN}$	2	4	6	ns
SDATA_IN Fall Time	$t_{FALLDIN}$	2	4	6	ns
SDATA_OUT Rise Time	$t_{RISEDOUT}$	2	4	6	ns
SDATA_OUT Fall Time	$t_{FALLDOUT}$	2	4	6	ns
End of Slot 2 to BIT_CLK, SDATA_IN Low	t_{S2_PDOWN}	0		1.0	μs
Setup to RESET Inactive (SYNC, SDATA_OUT)	$t_{SETUP2RST}$	15			ns
Rising Edge of RESET to Hi-Z Delay	t_{OFF}			25	ns
Propagation Delay				15	ns
RESET Rise Time				50	ns
Output Valid Delay from BIT_CLK Rising				15	ns

¹ Guaranteed but not tested.

² Output jitter directly dependent on crystal input jitter.

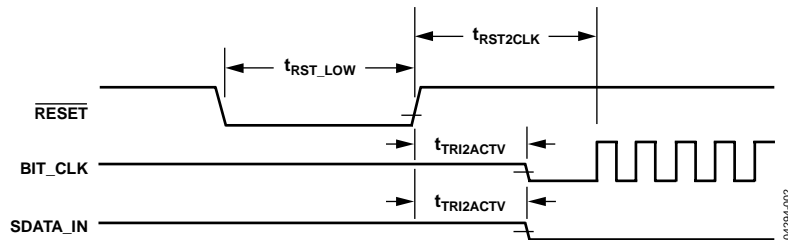

Figure 2. Cold Reset Timing (Codec is Supplying the Bit_CLK Signal)

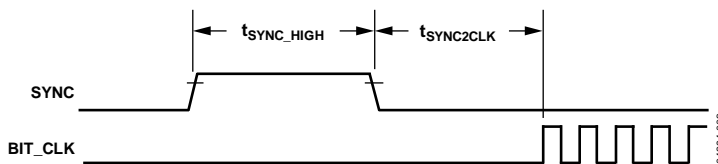

Figure 3. Warm Reset Timing

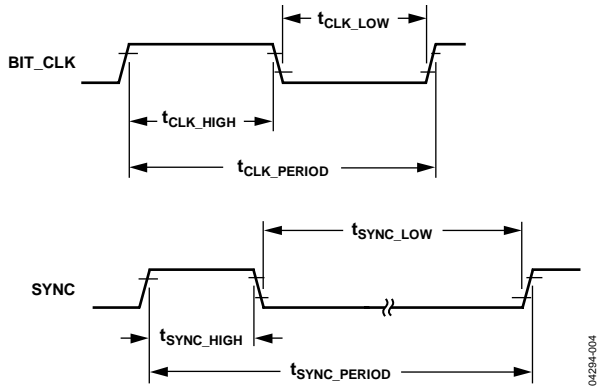

Figure 4. Clock Timing

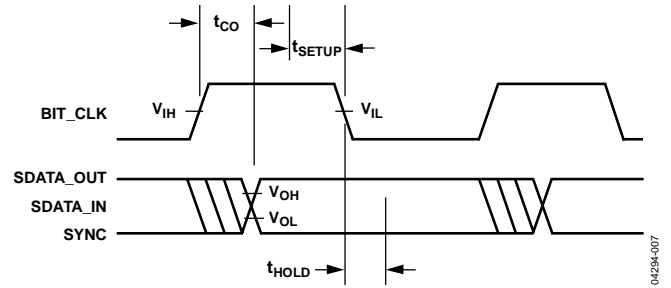

Figure 7. AC-Link Low Power Mode Timing

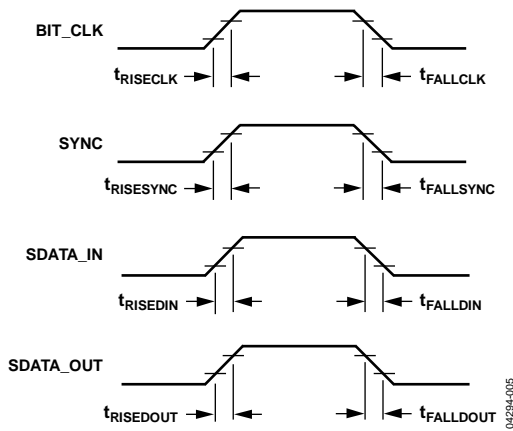

Figure 5. Signal Rise and Fall Times

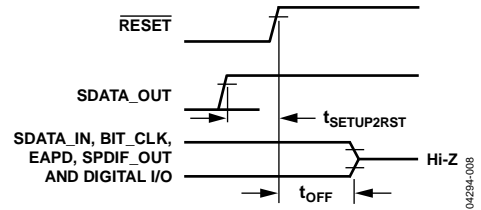

Figure 8. ATE Test Mode

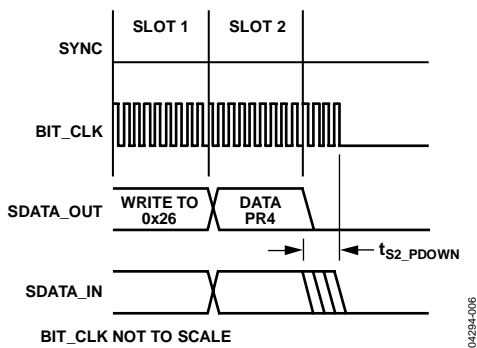

Figure 6. AC-Link low Power Mode Timing

ABSOLUTE MAXIMUM RATINGS

Table 3.

Parameter	Min	Max	Unit
Power Supplies			
Digital (DV _{DD})	-0.3	+3.6	V
Analog (AV _{DD})	-0.3	+6.0	V
Input Current (Except Supply Pins)		±10.0	mA
Analog Input Voltage (Signal Pins)	-0.3	AV _{DD} + 0.3	V
Digital Input Voltage (Signal Pins)	-0.3	DV _{DD} + 0.3	V
Ambient Temperature (Operating)	0	+70	°C
Storage Temperature	-65	+150	°C

Stresses greater than those listed under Absolute Maximum Ratings may cause permanent damage to the device. This is a stress rating only and functional operation of the device at these or any other conditions above those indicated in the operational section of this specification is not implied. Exposure to absolute maximum rating conditions for extended periods may affect device reliability.

ENVIRONMENTAL CONDITIONS

Ambient temperature rating:¹

TCASE = Case temperature in °C

PD = Power dissipation in W

θ_{JA} = Thermal resistance (junction-to-ambient)

θ_{JC} = Thermal resistance (junction-to-case)

¹ All measurements per EIA/JESD51 with 2S2P test board per EIA/JESD51-7.

Table 4.

Package	θ_{JA}	θ_{JC}
LQFP	50.1°C/W	17.8°C/W
LFCSP	50°C/W	25.88°C/W

ESD CAUTION

ESD (electrostatic discharge) sensitive device. Electrostatic charges as high as 4000 V readily accumulate on the human body and test equipment and can discharge without detection. Although this product features proprietary ESD protection circuitry, permanent damage may occur on devices subjected to high energy electrostatic discharges. Therefore, proper ESD precautions are recommended to avoid performance degradation or loss of functionality.



PIN CONFIGURATION AND FUNCTION DESCRIPTIONS

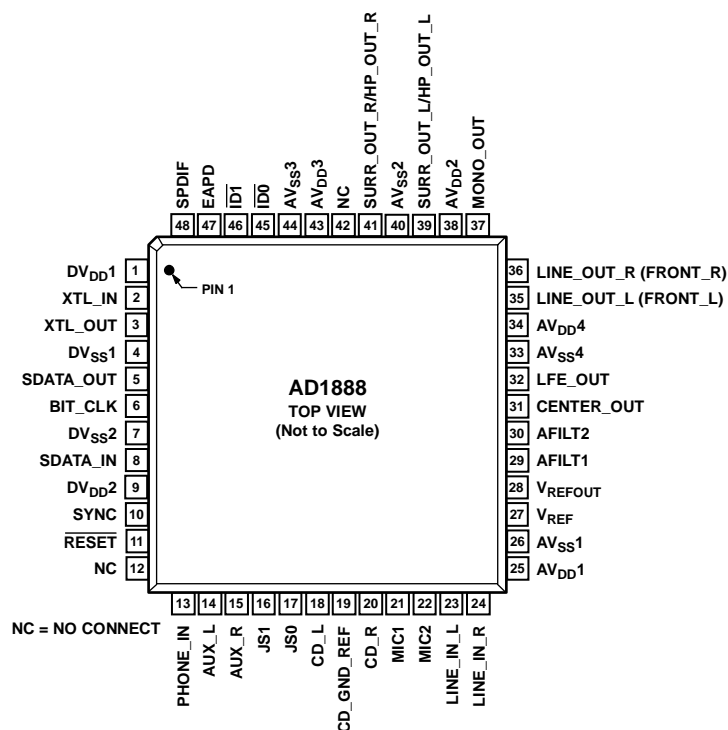

Figure 9. Pin Configuration

Table 5. Pin Function Descriptions

Pin No.	Mnemonic	I/O	Function
DIGITAL INPUT/OUTPUT			
2	XTL_IN	I	Crystal Input (24.576 MHz) or External Clock In (24.576 MHz, 14.31818 MHz, or 48000 MHz).
3	XTL_OUT	O	Crystal Output.
5	SDATA_OUT	I	AC-Link Serial Data Output. AD1888 input stream.
6	BIT_CLK	O/I	AC-Link Bit Clock. 12.288 MHz serial data clock. (Input pin for Secondary mode only.)
8	SDATA_IN	O	AC-Link Serial Data Input. AD1888 output stream.
10	SYNC	I	AC-Link Frame Sync.
11	RESET	I	AC-Link Reset. AD1888 master H/W reset.
48	SPDIF	O	SPDIF Output.
CHIP SELECTS/CLOCK STRAPPING			
45	ID0	I	Chip Select Input 0 (Active Low).
46	ID1	I	Chip Select Input 1 (Active Low).
JACK SENSE AND EAPD			
47	EAPD	O	EAPD Output.
17	JS0	I	Jack Sense 0 Input.
16	JS1	I	Jack Sense 1 Input.
ANALOG INPUT/OUTPUT			
13	PHONE_IN	I	Monaural Line-Level Input.
14	AUX_L	I	Auxiliary Input, Left Channel.
15	AUX_R	I	Auxiliary Input, Right Channel.
18	CD_L	I	CD Audio Left Channel.
19	CD_GND_REF	I	CD Audio Analog Ground Reference for Differential CD Input.
20	CD_R	I	CD Audio Right Channel.
21	MIC1	I	Rear Panel MIC Input.
22	MIC2	I	Front Panel MIC Input.

AD1888

Pin No.	Mnemonic	I/O	Function
23	LINE_IN_L	I	Line-In Left Channel.
24	LINE_IN_R	I	Line-In Right Channel.
31	CENTER_OUT	O	Center Channel Output.
32	LFE_OUT	O	Low Frequency Enhanced Output.
35	LINE_OUT_L	O	Line Out (Front) Left Channel.
36	LINE_OUT_R	O	Line Out (Front) Right Channel.
37	MONO_OUT	O	Monaural Output to Telephone Subsystem Speakerphone.
39	SURR_OUT_L/HP_OUT_L	O	Surround Front Headphone Left Channel Output.
41	SURR_OUT_R/HP_OUT_R	O	Surround Front Headphone Right Channel Output.
FILTER/REFERENCE			
27	V _{REF}	O	Voltage Reference Filter.
28	V _{REFOUT}	O	Voltage Reference Output 5 mA Drive (intended for MIC bias).
29	AFILT1	O	Antialiasing Filter Capacitor—ADC Right Channel.
30	AFILT2	O	Antialiasing Filter Capacitor—ADC Left Channel.
POWER AND GROUND SIGNALS			
1	DV _{DD1}	I	Digital V _{DD} 3.3 V.
4	DV _{SS1}	I	Digital GND.
7	DV _{SS2}	I	Digital GND.
9	DV _{DD2}	I	Digital V _{DD} 3.3 V.
25	AV _{DD1}	I	Analog V _{DD} 5.0 V.
26	AV _{SS1}	I	Analog GND.
33	AV _{SS4}	I	Analog GND.
34	AV _{DD4}	I	Analog V _{DD} 5.0 V.
38	AV _{DD2}	I	Analog V _{DD} 5.0 V.
40	AV _{SS2}	I	Analog GND.
43	AV _{DD3}	I	Analog V _{DD} 5.0 V.
44	AV _{SS3}	I	Analog GND.
NO CONNECTS			
12	NC		No Connect.
42	NC		No Connect.

Table 6. Indexed Control Registers

Reg	Name	D15	D14	D13	D12	D11	D10	D9	D8	D7	D6	D5	D4	D3	D2	D1	D0	Default
00h	Reset	X	SE4	SE3	SE2	SE1	SE0	ID9	ID8	ID7	ID6	ID5	ID4	ID3	ID2	ID1	ID0	0090h
02h	Master Volume	MM	X	LMV5	LMV4	LMV3	LMV2	LMV1	LMV0	MMRM ¹	X	RMV5	RMV4	RMV3	RMV2	RMV1	RMV0	8000h
04h	Headphone Volume	HPM	X	LHV5	LHV4	LHV3	LHV2	LHV1	LHV0	HPRM ¹	X	RHV5	RHV4	RHV3	RHV2	RHV1	RHV0	8000h
06h	Mono Volume	MVM	X	X	X	X	X	X	X	X	X	MV5	MV4	MV2	MV2	MV1	MV0	8000h
0Ch	Phone Volume	PHM	X	X	X	X	X	X	X	X	X	X	PHV4	PHV3	PHV2	PHV1	PHV0	8008h
0Eh	MIC Volume	MCM	X	X	X	X	X	X	X	X	M20	X	MCV4	MCV3	MCV2	MCV1	MCV0	8008h
10h	Line-In Volume	LVM	X	X	LLV4	LLV3	LLV2	LLV1	LLV0	LVRM ¹	X	X	RLV4	RLV3	RLV2	RLV1	RLV0	8808h
12h	CD Volume	CVM	X	X	LCV4	LCV3	LCV2	LCV1	LCV0	CDRM ¹	X	X	RCV4	RCV3	RCV2	RCV1	RCV0	8808h
16h	AUX Volume	AVM	X	X	LAV4	LAV3	LAV2	LAV1	LAV0	AVRM ¹	X	X	RAV4	RAV3	RAV2	RAV1	RAV0	8808h
18h	PCM Out Volume	OM	X	X	LOV4	LOV3	LOV2	LOV1	LOV0	OMRM ¹	X	X	ROV4	ROV3	ROV2	ROV1	ROV0	8808h
1Ah	Record Select	X	X	X	X	X	LS2	LS1	LS0	X	X	X	X	X	RS2	RS1	RS0	0000h
1Ch	Record Gain	IM	X	X	X	LIM3	LIM2	LIM1	LIM0	IMRM ¹	X	X	X	RIM3	RIM2	RIM1	RIM0	8000h
20h	General-Purpose	X	X	X	X	DRSS1	DRSS0	X	M5	LPBK	X	X	X	X	X	X	X	0000h
24h	Audio Int. and Paging	I4	X	X	X	I0	X	X	X	X	X	X	X	PG3	PG2	PG1	PG0	xxxxh
26h	Power-Down Ctrl/Stat	EAPD	PR6	PR5	PR4	PR3	PR2	PR1	PR0	X	X	X	X	REF	ANL	DAC	ADC	NA
28h	Ext'd Audio ID	ID1	ID0	X	X	REV1	REV0	AMAP	LDAC	SDAC	CDAC	DSA1	DSA0	X	SPDIF	DRA	VRA	x3C7h
2Ah	Ext'd Audio Stat/Ctrl	VFORCE	X	PRK	PRJ	PRI	SPCV	X	ELDAC	ESDAC	ECDAC	SPSA1	SPSA0	X	ESPDIF	EDRA	EVRA	0xx0h
2Ch	PCM Front DAC Rate	SRF15	SRF14	SRF13	SRF12	SRF11	SRF10	SRF9	SRF8	SRF7	SRF6	SRF5	SRF4	SRF3	SRF2	SRF1	SRF0	BB80h
2Eh	PCM Surr DAC Rate	SRS15	SRS14	SRS13	SRS12	SRS11	SRS10	SRS9	SRS8	SRS7	SRS6	SRS5	SRS4	SRS3	SRS2	SRS1	SRS0	BB80h
30h	PCM C/LFE DAC Rate	SRCL15	SRCL14	SRCL13	SRCL12	SRCL11	SRCL10	SRCL9	SRCL8	SRCL7	SRCL6	SRCL5	SRCL4	SRCL3	SRCL2	SRCL1	SRCL0	BB80h
32h	PCM L/R ADC Rate	SRA15	SRA14	SRA13	SRA13	SRA11	SRA10	SRA9	SRA8	SRA7	SRA6	SRA5	SRA4	SRA3	SRA2	SRA1	SRA0	BB80h
36h	Center/LFE Volume	LM	X	LFE5	LFE4	LFE3	LFE2	LFE1	LFE0	CM	X	CNT5	CNT4	CNT3	CNT2	CNT1	CNT0	8080h
38h	Surround Volume	MUTE_L	X	LSR5	LSR4	LSR3	LSR2	LSR1	LSR0	MUTE_R	X	RSR5	RSR4	RSR3	RSR2	RSR1	RSR0	8080h
3Ah	SPDIF Control	V	X	SPSR1	SPSR0	L	CC6	CC5	CC4	CC3	CC2	CC1	CC0	PRE	COPY	/AUD	PRO	2000h
72h	JACK SENSE	J5 SPRD	J51 DMX	J50 DMX	J5 MT2	J5 MT1	J5 MT0	X	X	J51 TMR	J50 TMR	J51 MD	J50 MD	J51 ST	J50 ST	J51 INT	J50 INT	0000h
74h	Serial Configuration	SLOT 16	REGM2	REGM1	REGM0	REGM3	DRF	X	CHEN	X	LBKS1	LBKS0	INTS	X	SPAL	SPDZ	SPLNK	1001h
76h	Misc Control Bits	DACZ	AC97NC	MSPLT	LODIS	CLDIS	HPSEL	DMIX1	DMIX0	SPRD	X	LOSEL	SRU	VREFH	VREFD	MBG1	MBG0	0000h
7Ch	Vendor ID1	F7	F6	F5	F4	F3	F2	F1	F0	S7	S6	S5	S4	S3	S2	S1	S0	4144h
7Eh	Vendor ID2	T7	T6	T5	T4	T3	T2	T1	T0	REV7	REV6	REV5	REV4	REV3	REV2	REV1	REV0	5368h

¹ For AC '97 compatibility, Bit D7 is only available by setting the MSPLT bit, Register 76h. The MSPLT bit enables separate mute bits for the left and right channels. If MSPLT is not set, Bit D7 has no effect.

All registers not shown and bits containing an X are assumed to be reserved.

Odd register addresses are aliased to the next lower even address.

Reserved registers should not be written to.

Zeros should be written to reserved bits.

AD1888

Table 7. Reset Register (Index 00h)

Reg No.	Name	D15	D14	D13	D12	D11	D10	D9	D8	D7	D6	D5	D4	D3	D2	D1	D0	Default
00h	Reset	X	SE4	SE3	SE2	SE1	SE0	ID9	ID8	ID7	ID6	ID5	ID4	ID3	ID2	ID1	ID0	0090h

All registers not shown and bits containing an X are assumed to be reserved.

Writing any value to this register performs a register reset, which causes all registers to revert to their default values (except 74h, which forces the serial configuration). Reading this register returns the ID code of the part and a code for the type of 3D Stereo Enhancement.

ID[9:0] Identify Capability. The ID decodes the capabilities of AD1888 based on the following:

Bit = 1	Function	AD1888
ID0	Dedicated Mic PCM In Channel	0
ID1	Modem Line Codec Support	0
ID2	Bass and Treble Control	0
ID3	Simulated Stereo (Mono to Stereo)	0
ID4	Headphone Out Support	1
ID5	Loudness (Bass Boost) Support	0
ID6	18-Bit DAC Resolution	0
ID7	20-Bit DAC Resolution	1
ID8	18-Bit ADC Resolution	0
ID9	20-Bit ADC Resolution	0

SE[4:0] Stereo Enhancement. The AD1888 does not provide hardware 3D stereo enhancement. (All bits are zeros.)

Table 8. Master Volume Register (Index 02h)

Reg No.	Name	D15	D14	D13 ¹	D12	D11	D10	D9	D8	D7	D6	D5 ¹	D4	D3	D2	D1	D0	Default
02h	Master Volume	MM	X	LMV5	LMV4	LMV3	LMV2	LMV1	LMV0	MMRM ²	X	RMV5	RMV4	RMV3	RMV2	RMV1	RMV0	8000h

¹ Refer to Table 10 for examples. This register controls the Line_Out volume controls for both stereo channels and mute bit. Each volume subregister contains five bits, generating 32 volume levels with 31 steps of 1.5 dB each. Because AC '97 defines 6-bit volume registers, to maintain compatibility whenever the D5 or D13 bits are set to 1, their respective lower five volume bits are automatically set to 1 by the codec logic. On readback, all lower five bits will read 1s whenever these bits are set to 1.

² For AC '97 compatibility, Bit D7 is available only by setting the MSPLT bit, Register 76h. The MSPLT bit enables separate mute bits for the left and right channels. If MSPLT is not set, Bit D7 has no effect. All registers not shown and bits containing an X are assumed to be reserved.

Note that depending on the state of the AC97NC bit in Register 0x76, this register has the following additional functionality:

For AC97NC = 0, the register controls the Line_out output Attenuators only.

For AC97NC = 1, the register controls the Line_out, Center, and LFE output Attenuators.

RMV[5:0]	Right Master Volume Control. The least significant bit represents 1.5 dB. This register controls the output from 0 dB to a maximum attenuation of 46.5 dB.
MMRM	Right Channel Mute. Once enabled by the MSPLT bit in Register 76h, this bit mutes the right channel separately from the MM bit. Otherwise this bit will always read 0 and will have no effect when set to 1.
LMV[5:0]	Left Master Volume Control. The least significant bit represents 1.5 dB. This register controls the output from 0 dB to a maximum attenuation of 46.5 dB.
MM	Headphones Volume Mute. When this bit is set to 1, both the left and the right channels are muted, unless the MSPLT bit in Register 76h is set to 1.

Table 9. Headphones Volume Register (Index 04h)

Reg No.	Name	D15	D14	D13	D12	D11	D10	D9	D8	D7	D6	D5	D4	D3	D2	D1	D0	Default
04h	Headphone Volume	HPM	X	LHV5	LHV4	LHV3	LHV2	LHV1	LHV0	HPRM ¹	X	RHV5	RHV4	RHV3	RHV2	RHV1	RHV0	8000h

Table 10. Volume Settings for Master and Headphone

Reg. 76h	Control Bits							
	Master Volume (02h) and Headphone Volume (04h)							
MSPLT ¹	Left Channel Volume D[13:8]				Right Channel Volume D[5:0]			
	D15	WRITE	READBACK	Function	D7 ¹	WRITE	READBACK	Function
0	0	00 0000	00 0000	0 dB Gain	x	00 0000	00 0000	0 dB Gain
0	0	00 1111	00 1111	-22.5 dB Gain	x	00 1111	00 1111	-22.5 dB Gain
0	0	01 1111	01 1111	-46.5 dB Gain	x	01 1111	01 1111	-46.5 dB Gain
0	0	1x xxxx	01 1111	-46.5 dB Gain	x	1x xxxx	01 1111	-46.5 dB Gain
0	1	xx xxxx	xx xxxx	-∞ dB Gain, Muted	x	xx xxxx	xx xxxx	-∞ dB Gain, Muted
1	0	1x xxxx	01 1111	-46.5 dB Gain	1	xx xxxx	xx xxxx	-∞ dB Gain, only Right Muted
1	1	xx xxxx	xx xxxx	-∞ dB Gain, Left only Muted	0	xx xxxx	xx xxxx	-46.5 dB Gain
1	1	xx xxxx	xx xxxx	-∞ dB Gain, Left Muted	1	xx xxxx	xx xxxx	-∞ dB Gain, Right Muted

¹ For AC '97 compatibility, Bit D7 is available only by setting the MSPLT bit, Register 76h. The MSPLT bit enables separate mute bits for the left and right channels. If MSPLT is not set, Bit D7 has no effect.
x in the above table is don't care.

Table 11. Mono Volume Register (Index 06h)

Reg No.	Name	D15	D14	D13	D12	D11	D10	D9	D8	D7	D6	D5 ¹	D4	D3	D2	D1	D0	Default
06h	Mono Volume	MVM	X	X	X	X	X	X	X	X	X	MV5	MV4	MV3	MV2	MV1	MV0	8000h

¹ Refer to Table 12 for examples. This register controls the Mono output volume and mute bit. The volume register contains five bits, generating 32 volume levels with 31 steps of 1.5 dB each. Because AC '97 defines 6-bit volume registers, to maintain compatibility, whenever the D5 bit is set to 1, their respective lower five volume bits are automatically set to 1 by the codec logic. On readback, all lower five bits will read 1s whenever this bit is set to 1. All registers not shown and bits containing an X are assumed to be reserved.

MV[5:0]	Mono Volume Control. The least significant bit represents 1.5 dB. This register controls the output from 0 dB to a maximum attenuation of 46.5 dB.
MVM	Mono Volume Mute. When this bit is set to 1, the channel is muted.

Table 12. Volume Settings for Mono

D15	Control Bits D[4:0] for Mono (06h)		Function
	WRITE	READBACK	
0	0 0000	0 0000	0 dB Gain
0	0 1111	0 1111	-22.5 dB Gain
0	1 1111	1 1111	-46.5 dB Gain
1	x xxxx	x xxxx	-∞ dB Gain, Muted

x in the above table is a wild card and has no effect on the value.

AD1888

Table 13. Phone_in Volume Register (Index 0Ch)

Reg No.	Name	D15	D14	D13	D12	D11	D10	D9	D8	D7	D6	D5	D4	D3	D2	D1	D0	Default
0Ch	Phone_in Volume	PHM	X	X	X	X	X	X	X	X	X	X	PHV4	PHV3	PHV2	PHV1	PHV0	8008h

All registers not shown and bits containing an X are assumed to be reserved. Refer to Table 15 for examples.

PHV[4:0]	Phone Volume. Allows setting the Phone Volume attenuator in 32 volume levels with 31 steps of 1.5 dB each. The LSB represents 1.5 dB, and the gain range is +12 dB to -34.5 dB. The default value is 0 dB, with the mute bit enabled.
PHM	Phone Mute. When this bit is set to 1, the Phone channel is muted.

Table 14. MIC Volume Register (Index 0Eh)

Reg No.	Name	D15	D14	D13	D12	D11	D10	D9	D8	D7	D6	D5	D4	D3	D2	D1	D0	Default
0Eh	MIC Volume	MCM	X	X	X	X	X	X	X	X	M20	X	MCV4	MCV3	MCV2	MCV1	MCV0	8008h

All registers not shown and bits containing an X are assumed to be reserved. Refer to Table 15 for examples.

MCV[4:0]	MIC Volume Gain. Allows setting the MIC Volume attenuator in 32 volume levels. The LSB represents 1.5 dB, and the gain range is +12 dB to -34.5 dB. The default value is 0 dB, with mute enabled.
M20	MIC Gain Boost. This bit allows setting additional MIC gain to increase the microphone sensitivity. The nominal gain boost by default is 20 dB; however, Bits D0 and D1 (MBG[1:0]) on the miscellaneous control bits register (76h) allow changing the gain boost to 10 dB or 30 dB, if necessary. 0 = Disabled; Gain = 0 dB 1 = Enabled; Default Gain = 20 dB (see Register 76h, Bits D0, D1)
MCM	MIC Mute. When this bit is set to 1, the channel is muted.

Table 15. Volume Settings for Phone and MIC

D15	Control Bits D[4:0] Phone (0Ch) and MIC (0Eh)		Function
	WRITE	READBACK	
0	0 0000	0 0000	12 dB Gain
0	0 1000	0 1000	0 dB Gain
0	1 1111	1 1111	-34.5 dB Gain
1	x xxxx	x xxxx	-∞ dB Gain, Muted

x in the above table is a wild card, and has no effect on the value.

Table 16. Line-In Volume Register (Index 10h)

Reg No.	Name	D15	D14	D13	D12	D11	D10	D9	D8	D7	D6	D5	D4	D3	D2	D1	D0	Default
10h	Line-In Volume	LVM	X	X	LLV4	LLV3	LLV2	LLV1	LLV0	LVRM ¹	X	X	RLV4	RLV3	RLV2	RLV1	RLV0	8808h

¹ For AC '97 compatibility, Bit D7 is available only by setting the MSPLT bit, Register 76h. The MSPLT bit enables separate mute bits for the left and right channels.

If MSPLT is not set, the Bit D7 has no effect. All registers not shown and bits containing an X are assumed to be reserved. Refer to Table 20 for examples.

RLV[4:0]	Right Line-In Volume. Allows setting the Line-In Right channel attenuator in 32 volume levels with 31 steps of 1.5 dB each. The LSB represents 1.5 dB, and the range is +12 dB to –34.5 dB. The default value is 0 dB, mute enabled.
LVRM	Right Channel Mute. Once enabled by the MSPLT bit in Register 76h, this bit mutes the right channel separately from the LIM bit. Otherwise, this bit will always read 0 and will have no effect when set to 1.
LLV[4:0]	Left Line-In Volume. Allows setting the Line-In left channel attenuator in 32 volume levels with 31 steps of 1.5 dB each. The LSB represents 1.5 dB, and the range is +12 dB to –34.5 dB. The default value is 0 dB, mute enabled.
LVM	Line-In Mute. When this bit is set to 1, both the left and the right channels are muted, unless the MSPLT bit in Register 76h is set to 1, in which case this mute bit will only affect the left channel.

Table 17. CD Volume Register (Index 12h)

Reg No.	Name	D15	D14	D13	D12	D11	D10	D9	D8	D7	D6	D5	D4	D3	D2	D1	D0	Default
12h	CD Volume	CVM	X	X	LCV4	LCV3	LCV2	LCV1	LCV0	CDRM ¹	X	X	RCV4	RCV3	RCV2	RCV1	RCV0	8808h

¹ For AC '97 compatibility, Bit D7 is available only by setting the MSPLT bit, Register 76h. The MSPLT bit enables separate mute bits for the left and right channels.

If MSPLT is not set, the Bit D7 has no effect. All registers not shown and bits containing an X are assumed to be reserved. Refer to Table 20 or examples.

RCV[4:0]	Right CD Volume. Allows setting the CD right channel attenuator in 32 volume levels with 31 steps of 1.5 dB each. The LSB represents 1.5 dB, and the range is +12 dB to –34.5 dB. The default value is 0 dB, mute enabled.
CDRM	Right Channel Mute. Once enabled by the MSPLT bit in Register 76h, this bit mutes the Right channel separately from the CVM bit. Otherwise this bit will always read 0 and will have no effect when set to 1.
LCV[4:0]	Left CD Volume. Allows setting the CD left channel attenuator in 32 volume levels with 31 steps of 1.5 dB each. The LSB represents 1.5 dB, and the range is +12 dB to –24.5 dB. The default value is 0 dB, mute enabled.
CVM	CD Volume Mute. When this bit is set to 1, both the left and the right channels are muted, unless the MSPLT bit in Register 76h is set to 1, in which case this mute bit will affect only the left channel.

Table 18. AUX Volume Register (Index 16h)

Reg No.	Name	D15	D14	D13	D12	D11	D10	D9	D8	D7	D6	D5	D4	D3	D2	D1	D0	Default
16h	AUX Volume	AVM	X	X	LAV4	LAV3	LAV2	LAV1	LAV0	AVRM ¹	X	X	RAV4	RAV3	RAV2	RAV1	RAV0	8808h

¹ For AC '97 compatibility, Bit D7 is only available by setting the MSPLT bit, Register 76h. The MSPLT bit enables separate mute bits for the left and right channels.

If MSPLT is not set, Bit D7 has no effect. All registers not shown and bits containing an X are assumed to be reserved. Refer to Table 20 for examples.

RAV[4:0]	Right AUX Volume. Allows setting the AUX right channel attenuator in 32 volume levels with 31 steps of 1.5 dB each. The LSB represents 1.5 dB, and the range is +12 dB to –34.5 dB. The default value is 0 dB, mute enabled.
AVRM	Right Channel Mute. Once enabled by the MSPLT bit in Register 76h, this bit mutes the right channel separately from the AVM bit. Otherwise, this bit will always read 0 and will have no affect when set to 1.
LAV[4:0]	Left PCM Out Volume. Allows setting the PCM left channel attenuator in 32 volume levels. The LSB represents 1.5 dB, and the range is +12 dB to –34.5 dB. The default value is 0 dB, mute enabled.
AVM	PCM Out Volume Mute. When this bit is set to 1, both the left and the right channels are muted, unless the MSPLT bit in Register 76h is set to 1, in which case this mute bit will affect only the left channel.

AD1888

Table 19. PCM-Out Volume Register (Index 18h)

Reg No.	Name	D15	D14	D13	D12	D11	D10	D9	D8	D7	D6	D5	D4	D3	D2	D1	D0	Default
18h	PCM Out Volume	OM	X	X	LOV4	LOV3	LOV2	LOV1	LOV0	OMRM ¹	X	X	ROV4	ROV3	ROV2	ROV1	ROV0	8808h

¹ For AC '97 compatibility, Bit D7 is available only by setting the MSPLT bit, Register 76h. The MSPLT bit enables separate mute bits for the left and right channels.

If MSPLT is not set, Bit D7 has no effect. All registers not shown and bits containing an X are assumed to be reserved. Refer to Table 20 for examples.

Note that depending on the state of the AC97NC bit in Register 76h, this register has the following additional functionality:

For AC97NC = 0, the register also controls the Surround, Center, and LFE DAC Gain/Attenuators.

For AC97NC = 1, the register controls the PCM Out Volume only.

ROV[4:0]	Right PCM Out Volume. Allows setting the PCM right channel attenuator in 32 volume levels. The LSB represents 1.5 dB, and the gain range is +12 dB to -34.5 dB. The default value is 0 dB, mute enabled.
OMRM	Right Channel Mute. Once enabled by the MSPLT bit in Register 76h, this bit mutes the right channel separately from the AVMM bit. Otherwise, this bit will always read 0 and will have no affect when set to 1.
LOV[4:0]	Left PCM Out Volume. Allows setting the PCM left channel attenuator in 32 volume levels. The LSB represents 1.5 dB, and the range is +12 dB to -34.5 dB. The default value is 0 dB, mute enabled.
OM	PCM Out Volume Mute. When this bit is set to 1, both the left and the right channels are muted, unless the MSPLT bit in Register 76h is set to 1, in which case this mute bit will affect only the left channel.

Table 20. Volume Settings for Line-In, CD Volume, AUX, and PCM-Out

Reg. 76h	Control Bits							
	Line-In (10h), CD (12h), AUX (16h) and PCM-Out (18h)							
	Left Channel Volume D[12:8]				Right Channel Volume D[4:0]			
MSPLT ¹	D15	WRITE	READBACK	Function	D7 ¹	WRITE	READBACK	Function
0	0	0 0000	0 0000	12 dB Gain	x	0 0000	0 0000	12 dB Gain
0	0	0 1000	0 1000	0 dB Gain	x	0 1000	0 1000	0 dB Gain
0	0	1 1111	1 1111	-34.5 dB Gain	x	1 1111	1 1111	-34.5 dB Gain
0	1	x xxxx	x xxxx	-∞ dB Gain, Muted	x	x xxxx	x xxxx	-∞ dB Gain, Muted
1	0	1 1111	1 1111	-34.5 dB Gain	1	x xxxx	x xxxx	-∞ dB Gain, Right Only Muted
1	1	x xxxx	x xxxx	-∞ dB Gain, Left Only Muted	0	1 1111	1 1111	-34.5 dB Gain
1	1	x xxxx	x xxxx	-∞ dB Gain, Left Muted	1	x xxxx	x xxxx	-∞ dB Gain, Right Muted

¹ For AC '97 compatibility, Bit D7 is only available by setting the MSPLT bit, Register 76h. The MSPLT bit enables separate mute bits for the left and right channels.

If MSPLT is not set, RM Bit has no effect.

x in the above table is don't care.

Table 21. Record Select Control Register (Index 1Ah)

Reg No.	Name	D15	D14	D13	D12	D11	D10	D9	D8	D7	D6	D5	D4	D3	D2	D1	D0	Default
1Ah	Record Select	X	X	X	X	X	LS2	LS1	LS0	X	X	X	X	X	RS2	RS1	RS0	0000h

All registers not shown and bits containing an X are assumed to be reserved.

Refer to Table 22 for examples. Used to select the record source independently for the right and left channels. For MIC recording, see MS bit (Register 20h) for MIC1 and MIC2 input selection.

RS [2:0]	Right Record Select
LS [2:0]	Left Record Select

Table 22. Settings for Record Select Control

LS [10:8]	Left Record Source	RS [2:0]	Right Record Source
000	MIC	000	MIC
001	CD_L	001	CD_R
010	Muted	010	Muted
011	AUX_L	011	AUX_R
100	LINE_IN_L	100	LINE_IN_R
101	Stereo Mix (L)	101	Stereo Mix (R)
110	Mono Mix	110	Mono Mix
111	PHONE_IN	111	PHONE_IN

Table 23. Record Gain Register (Index 1Ch)

Reg No.	Name	D15	D14	D13	D12	D11	D10	D9	D8	D7	D6	D5	D4	D3	D2	D1	D0	Default
1Ch	Record Gain	IM	X	X	X	LIM3	LIM2	LIM1	LIM0	IMRM ¹	X	X	X	RIM3	RIM2	RIM1	RIM0	8000h

¹ For AC '97 compatibility, Bit D7 is available only by setting the MSPLT bit, Register 76h. The MSPLT bit enables separate mute bits for the left and right channels.

If MSPLT is not set, Bit D7 has no effect. All registers not shown and bits containing an X are assumed to be reserved. Refer to Table 24 for examples.

RIM[3:0]	Right Input Mixer Gain Control. Each LSB represents 1.5 dB, 0000 = 0 dB, and the gain range is 0 dB to 22.5 dB.
IMRM	Right Channel Mute. Once enabled by the MSPLT bit in Register 76h, this bit mutes the right channel separately from the IM bit. Otherwise, this bit will always read 0 and will have no effect when set to 1.
LIM[3:0]	Left Input Mixer Gain Control. Each LSB represents 1.5 dB, 0000 = 0 dB, and the gain range is 0 dB to 22.5 dB.
IM	Input Mute. When this bit is set to 1, both the left and the right channels are muted, unless the MSPLT bit in Register 76h is set to 1, in which case this mute bit will affect only the left channel.

Table 24. Settings for Record Gain Register

Reg. 76h	Control Bits Record Gain (1Ch)								
	Left Channel Input Mixer D[11:8]				Right Channel Input Mixer D[3:0]				
	MSPLT ¹	D15	WRITE	READBACK	Function	D7 ¹	WRITE	READBACK	Function
	0	0	1111	1111	22.5 dB Gain	x	1111	1111	22.5 dB Gain
	0	0	0000	0000	0 dB Gain	x	0000	0000	0 dB Gain
	0	1	xxxx	xxxx	-∞ dB Gain, Muted	x	xxxx	xxxx	-∞ dB Gain, Muted
	1	0	1111	1111	22.5 dB Gain	1	xxxx	xxxx	-∞ dB Gain, Right Only Muted
	1	1	xxxx	xxxx	-∞ dB Gain, Left Only Muted	0	1111	1111	22.5 dB Gain
	1	1	xxxx	xxxx	-∞ dB Gain, Left Muted	1	xxxx	xxxx	-∞ dB Gain, Right Muted

¹ For AC '97 compatibility, Bit D7 (RM) is available only by setting the MSPLT bit, Register 76h. The MSPLT bit enables separate mute bits for the left and right channels. If MSPLT is not set, Bit D7 has no effect.

x is don't care.

AD1888

Table 25. General-Purpose Register (Index 20h)

Reg No.	Name	D15	D14	D13	D12	D11	D10	D9	D8	D7	D6	D5	D4	D3	D2	D1	D0	Default
20h	General-Purpose	X	X	X	X	DRSS1	DRSS0	X	MS	LPBK	X	X	X	X	X	X	X	0000h

This register should be read before writing to generate a mask only for the bit(s) that need to be changed. All registers not shown and bits containing an X are assumed to be reserved.

LPBK	<p>Loopback Control. This bit enables the digital internal loopback from the ADC to the front DAC. This feature is normally used for test and troubleshooting.</p> <p>0 = No Loopback (Default)</p> <p>1 = Loopback PCM digital data from ADC output to DAC</p> <p>See LBKS bit in Register 0x74 for changing the loopback path to use the Surround or Center/LFE DACs.</p>
MS	<p>MIC Select. Selects Mono MIC input.</p> <p>0 = Select MIC1, from rear panel MIC jack</p> <p>1 = Select MIC2, from front panel MIC jack</p>
DRSS [1:0]	<p>Double Rate Slot Select. The DRSS bits specify the slots for the n + 1 sample outputs. PCM L (n + 1) and PCM R (n + 1) data are by default provided in output slots 10 and 11.</p> <p>00: PCM L, R n + 1 Data is on Slots 10, 11 (reset default)</p> <p>01: PCM L, R n + 1 Data is on Slots 7, 8</p> <p>10: Reserved</p> <p>11: Reserved</p>

Table 26. Audio Interrupt and Paging Mechanism Register (Index 24h)

Reg No.	Name	D15	D14	D13	D12	D11	D10	D9	D8	D7	D6	D5	D4	D3	D2	D1	D0	Default
24h	Audio Interrupt and Paging	I4	X	X	X	I0	X	X	X	X	X	X	X	PG3	PG2	PG1	PG0	xxxxh

This register controls the audio interrupt and paging mechanism. All registers not shown and bits containing an X are assumed to be reserved.

PG[3:0]	<p>Page Selector (Read Only). This register is used to describe page selector capability for extended features. Reading these bits returns 0h, which describes page selection as vendor specific only.</p>
I0	<p>INTERRUPT ENABLE (R/W). This enables interrupt generation.</p> <p>0 = Interrupt Generation is Masked (Default)</p> <p>1 = Interrupt Generation is Unmasked</p> <p>The S/W should not unmask the interrupt unless ensured by the AC '97 controller that no conflict is possible with modem slot 12 GPI functionality.</p> <p>AC '97 2.2 compliant controllers will not likely support audio codec interrupt infrastructure. In that case, S/W could poll the interrupt status after initiating a sense cycle and waiting for Sense Cycle Max Delay to determine if an interrupting event has occurred.</p>
I4	<p>INTERRUPT STATUS (R/W). This bit provides interrupt status and clear capability.</p> <p>0 = Interrupt is Clear</p> <p>1 = Interrupt was Generated</p> <p>Interrupt event is cleared by writing a 1 to this bit. The interrupt bit will change regardless of condition of interrupt enable (I0) status. An interrupt in the GPI in slot 12 in the ac link will follow this bit change when interrupt enable (I0) is unmasked.</p>

Table 27. Power-Down Control/Status Register (Index 26h)

Reg No.	Name	D15	D14	D13	D12	D11	D10	D9	D8	D7	D6	D5	D4	D3	D2	D1	D0	Default
26h	Power-Down Control/Status	EAPD	PR6	PR5	PR4	PR3	PR2	PR1	PR0	X	X	X	X	REF	ANL	DAC	ADC	NA

The ready bits are read only; writing to REF, ANL, DAC, ADC will have no effect. These bits indicate the status for the AD1888 subsections. If the bit is a 1, then that subsection is ready. Ready is defined as the subsection able to perform in its nominal state. All registers not shown and bits containing an X are assumed to be reserved.

ADC	ADC Sections Ready to Transmit Data
DAC	DAC Sections Ready to Transmit Data
ANL	Analog Amplifiers, Attenuators, and Mixers Ready
REF	Voltage References, V_{REF} and V_{REFOUT} , up to Nominal Level
PR[6:0]	Codec Power-Down Modes. The first three bits are to be used individually rather than in combination with each other. PR3 can be used in combination with PR2 or by itself. The mixer and reference cannot be powered down via PR3 unless the ADCs and DACs are also powered down. Nothing else can be powered up until the reference is up. PR5 has no effect unless all ADCs, DACs, and the ac-link are powered down. The reference and the mixer can be either up or down, but all power-up sequences must be allowed to run to completion before PR5 and PR4 are both set. In multiple codec systems, the master codec's PR5 and PR4 bits control the slave codec. PR5 is also effective in the slave codec if the master's PR5 bit is clear, but the PR4 bit has no effect except to enable or disable PR5.
EAPD	External Audio Power-Down Control. Controls the state of the EAPD pin. EAPD = 0 sets the EAPD pin low, enabling an external power amplifier (reset defaults). EAPD = 1 sets the EAPD pin high, shutting off the external power amplifier.

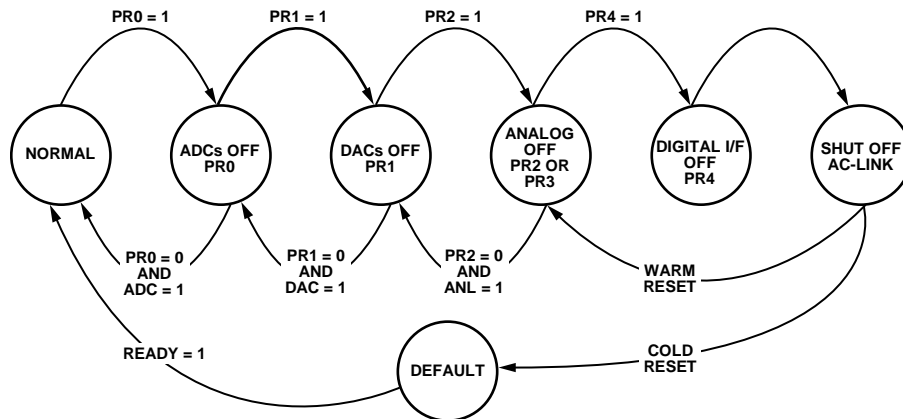

Figure 10. One Example of AC '97 Power-Down/Power-Up Flow

Table 28. Extended Audio ID Register (Index 28h)

Reg No.	Name	D15	D14	D13	D12	D11	D10	D9	D8	D7	D6	D5	D4	D3	D2	D1	D0	Default
28h	Ext'd Audio ID	ID1	ID0	X	X	REV1	REV0	AMAP	LDAC	SDAC	CDAC	DSA1	DSA0	X	SPDIF	DRA	VRA	x3C7h

The extended audio ID register identifies which extended audio features are supported. A nonzero extended audio ID value indicates one or more of the extended audio features are supported. All registers not shown and bits containing an X are assumed to be reserved.

VRA	Variable Rate PCM Audio Support (Read Only). This bit returns a 1 when read to indicate that the Variable Rate PCM Audio is supported.
DRA	Double Rate Audio (Read Only). This bit returns a 1 when read to indicate that the optional Double Rate RCM Audio is supported for PCM L and PCM R.
SPDIF	SPDIF Support (Read Only). This bit returns a 1 when read to indicate that the SPDIF transmitter is supported (IEC958). This bit is also used to validate that the SPDIF transmitter output is actually enabled. The SPDIF bit is only allowed to be set high if the SPDIF pin (48) is pulled down at power-up, enabling the codec transmitter logic. If the SPDIF pin is floating or pulled high at power-up, the transmitter logic is disabled and therefore this bit returns a low, indicating that the SPDIF transmitter is not available. This bit must always be read back to verify that the SPDIF transmitter is actually enabled.
DSA[1,0]	DAC Slot Assignments (Read/Write) (Reset Default = 00) 00 DACs 1, 2 = 3 and 4 DACs 3, 4 = 7 and 8 DACs 5, 6 = 6 and 9 01 DACs 1, 2 = 7 and 8 DACs 3, 4 = 6 and 9 DACs 5, 6 = disabled 10 DACs 1, 2 = 6 and 9 DACs 3, 4 = disabled DACs 5, 6 = disabled 11 Reserved
CDAC	PCM CENTER DAC Support (Read Only). This bit returns a 1 when read to indicate that PCM center DAC is supported.
SDAC	PCM Surround DAC Support (Read Only). This bit returns a 1 when read to indicate that PCM surround left and right DACs are supported.
LDAC	PCM LFE DAC Support (Read Only), This bit returns a 1 when read to indicate that PCM LFE DAC is supported.
AMAP	Slot DAC Mappings Based on Codec ID (Read Only). This bit returns a 1 when read to indicate that slot/DAC mappings based on codec ID are supported.
REV[1,0]	REV[1,0] = 01 indicates codec is AC '97 revision 2.2 compliant (Read Only).
ID[1:0]	Indicates Codec Configuration (Read Only). 00 = Primary 01, 10, 11 = Secondary

Table 29. Extended Audio Status and Control Register (Index 2Ah)

Reg No.	Name	D15	D14	D13	D12	D11	D10	D9	D8	D7	D6	D5	D4	D3	D2	D1	D0	Default
2Ah	Extended Audio Stat/Ctrl	VFORCE	X	PRK	PRJ	PRI	SPCV	X	ELDAC	ESDAC	ECDAC	SPSA1	SPSA0	X	ESPDIF	EDRA	EVRA	0xx0h

The extended audio status and control register is a read/write register that provides status and control of the extended audio features. All registers not shown and bits containing an X are assumed to be reserved.

EVRA	Variable Rate Audio (Read/Write). EVRA = 0, sets fixed sample rate audio at 48 kHz (Reset Default). EVRA = 1, enables variable rate audio mode (enables sample rate registers and SLOTREQ signaling).
EDRA	Double Rate Audio. EDRA = 1 enables double rate audio mode in which data from PCM L and PCM R in output slots 3 and 4 is used in conjunction with PCM L (n + 1) and PCM R (n + 1) data to provide DAC streams at twice the sample rate designated by the PCM front sample rate control register. When using the double rate audio, only the front DACs are supported and all other DACs (surround, center, and LFE) are automatically powered down. Note that EDRA can be used without VRA; in that case, the converter rates are forced to 96 kHz if EDRA = 1.
ESPDIF	SPDIF Transmitter Subsystem Enable/Disable Bit (Read/Write). ESPDIF = 1 enables the SPDIF transmitter. ESPDIF = 0 disables the SPDIF transmitter (default).
SPSA[1,0]	SPDIF Slot Assignment Bits (Read/Write). These bits control the SPDIF slot assignment and respective defaults, depending on the codec ID configuration. See the following table.
ECDAC	Center DAC Status (Read Only). ECDAC = 1 indicates the PCM center DAC is ready.
ESDAC	Surround DAC status (Read Only). ESDAC = 1 indicates the PCM surround DACs are ready.
ELDAC	LFE DAC status (Read Only). ELDAC = 1 indicates the PCM LFE DAC is ready.
SPCV	SPDIF Configuration Valid (Read Only). Indicates the status of the SPDIF transmitter subsystem, enabling the driver to determine if the currently programmed SPDIF configuration is supported. SPCV is always valid, independent of the SPDIF enable bit status. SPCV = 0 indicates current SPDIF configuration (SPSA, SPSR, DAC slot rate, DRS) is not valid (not supported). SPCV = 1 indicates current SPDIF configuration (SPSA, SPSR, DAC slot rate, DRS) is valid (supported).
PRI	Center DAC Power-Down (Read/Write). PRI = 1 turns off the PCM Center DAC.
PRJ	Surround DACs Power-Down (Read/Write). PRJ = 1 turns off the PCM surround DACs.
PRK	LFE DAC Power-Down (Read/Write). PRK = 1 turns off the PCM LFE DAC.
VFORCE	Validity Force Bit (Reset Default = 0). When asserted, this bit forces the SPDIF stream validity flag (Bit 28 within each SPDIF L/R subframe) to be controlled by the V bit (D15) in Register 3Ah (SPDIF control register). VFORCE = 0 and V = 0; the Validity Bit is managed by the codec error detection logic. VFORCE = 0 and V = 1; the Validity Bit is forced high, indicating subframe data is invalid. VFORCE = 1 and V = 0; the Validity Bit is forced low, indicating subframe data is valid. VFORCE = 1 and V = 1; the Validity Bit is forced high, indicating subframe data is invalid.

AD1888

Table 30. AC '97 2.2 AMAP Compliant Default SPDIF Slot Assignments

Codec ID	Function	SPSA = 00	SPSA = 01	SPSA = 10	SPSA = 11
00	2-Ch Primary w/SPDIF	3 and 4	7 and 8 [default]	6 and 9	10 and 11
00	4-Ch Primary w/SPDIF	3 and 4	7 and 8	6 and 9[default]	10 and 11
00	6-Ch Primary w/SPDIF	3 and 4	7 and 8	6 and 9	10 and 11[default]
01	+2-Ch Secondary w/SPDIF	3 and 4	7 and 8	6 and 9[default]	
01	+4-Ch Secondary w/SPDIF	3 and 4	7 and 8	6 and 9	10 and 11[default]
10	+2-Ch Secondary w/SPDIF	3 and 4	7 and 8	6 and 9[default]	
10	+4-Ch Secondary w/SPDIF	3 and 4	7 and 8	6 and 9	10 and 11[default]
11	+2-Ch Secondary w/SPDIF	3 and 4	7 and 8	6 and 9	10 and 11[default]

Table 31. PCM Front DAC Rate Register (Index 2Ch)

Reg No.	Name	D15	D14	D13	D12	D11	D10	D9	D8	D7	D6	D5	D4	D3	D2	D1	D0	Default
2Ch	PCM Front DAC Rate	SRF15	SRF14	SRF13	SRF12	SRF11	SRF10	SRF9	SRF8	SRF7	SRF6	SRF5	SRF4	SRF3	SRF2	SRF1	SRF0	BB80h

This read/write Sample Rate Control Register contains 16-bit unsigned value, representing the rate of operation in Hz.

SRF[15:0]	<p>Sample Rate</p> <p>The sampling frequency range is from 7 kHz (1B58h) to 48 kHz (BB80h) in 1 Hz increments. If zero is written to EVRA, the sample rate is reset to 48 kHz.</p>
-----------	---

Table 32. PCM Surround DAC Rate Register (Index 2Eh)

Reg No.	Name	D15	D14	D13	D12	D11	D10	D9	D8	D7	D6	D5	D4	D3	D2	D1	D0	Default
2Eh	PCM Surr DAC Rate	SRS15	SRS14	SRS13	SRS12	SRS11	SRS10	SRS9	SRS8	SRS7	SRS6	SRS5	SRS4	SRS3	SRS2	SRS1	SRS0	BB80h

This read/write Sample Rate Control Register contains 16-bit unsigned value, representing the rate of operation in Hz.

This register sets the sample rate for the surround DAC. This register's reset default is to be locked to the PCM front DAC sample rate register (2-Ch).

To unlock this register, Bit SRU in Register 76h must be asserted.

SRF[15:0]	<p>Sample Rate</p> <p>The sampling frequency range is from 7 kHz (1B58h) to 48 kHz (BB80h) in 1 Hz increments. If zero is written to EVRA, the sample rate is reset to 48 kHz.</p>
-----------	---

Table 33. PCM LFE (and CENTER) DAC Rate Register (Index 30h)

Reg No.	Name	D15	D14	D13	D12	D11	D10	D9	D8	D7	D6	D5	D4	D3	D2	D1	D0	Default
30h	PCM LFE/C DAC Rate	SRCL15	SRCL14	SRCL13	SRCL12	SRCL11	SRCL10	SRCL9	SRCL8	SRCL7	SRCL6	SRCL5	SRCL4	SRCL3	SRCL2	SRCL1	SRCL0	BB80h

This read/write sample rate control register contains 16-bit unsigned value, representing the rate of operation in Hz.

This register sets the sample rate for the LFE DAC and Center DAC. This register's reset default is to be locked to the PCM Front DAC sample rate register (2-Ch)

To unlock the register bit, SRU in Register 76h must be asserted.

SRF[15:0]	<p>Sample Rate</p> <p>The sampling frequency range is from 7 kHz (1B58h) to 48 kHz (BB80h) in 1 Hz increments. If zero is written to EVRA, the sample rate is reset to 48 kHz.</p>
-----------	---

Table 34. PCM ADC Rate Register (Index 32h)

Reg No.	Name	D15	D14	D13	D12	D11	D10	D9	D8	D7	D6	D5	D4	D3	D2	D1	D0	Default
32h	PCM L/R ADC Rate	SRA15	SRA14	SRA13	SRA12	SRA11	SRA10	SRA9	SRA8	SRA7	SRA6	SRA5	SRA4	SRA3	SRA2	SRA1	SRA0	BB80h

This read/write sample rate control register contains 16-bit unsigned value, representing the rate of operation in Hz.

SRF[15:0] Sample Rate

The sampling frequency range is from 7 kHz (1B58h) to 48 kHz (BB80h) in 1 Hz increments. If zero is written to EVRA, the sample rate is reset to 48 kHz.

Table 35. CENTER/LFE Volume Control Register (Index 36h)

Reg No.	Name	D15	D14	D13 ¹	D12	D11	D10	D9	D8	D7	D6	D5 ¹	D4	D3	D2	D1	D0	Default
36h	Center/LFE Volume	LM	X	LFE5	LFE4	LFE3	LFE2	LFE1	LFE0	CM	X	CNT5	CNT4	CNT3	CNT2	CNT1	CNT0	8080h

¹ Because AC '97 defines 6-bit volume registers, to maintain compatibility, whenever the D5 or D13 bit is set to 1, its respective lower five volume bits are automatically set to 1 by the codec logic. On readback, all lower five bits will read 1s whenever this bit is set to 1.

All registers not shown and bits containing an X are assumed to be reserved.

Refer to Table 36 for examples. This register controls the LFE output volume and mute bit. The volume registers contain five bits, generating 32 volume levels with 31 steps of 1.5 dB each. If MSPLT is not set, Bit D7 has no effect.

Note that depending on the state of the AC97NC bit in Register 76h, this register operates as follows:

For AC97NC = 0, the register controls the center and LFE output pin attenuators. Range is 0 dB to –46.5 dB.

For AC97NC = 1, the register controls the center and LFE DAC gain/attenuators. Range is +12 dB to –34.5 dB.

CNT[5:0]	Center Volume Control
CM	Center Volume Mute. When this bit is set to 1, the channel is muted.
LFE[5:0]	LFE Volume Control
LM	LFE Volume Mute. When this bit is set to 1, the channel is muted.

Table 36. Settings for Center/LFE Register

**Control Bits
CENTER and LFE Volume (36h)**

D15/D7	CENTER D[5:0] and LFE D[13:8]		Function with AC97NC = 0	Function with AC97NC = 1
	WRITE	READBACK		
0	00 0000	00 0000	0 dB Gain	12 dB Gain
0	00 1111	00 1111	–22 dB Gain	–10.5 dB Gain
0	01 1111	01 1111	–46.5 dB Gain	–34.5 dB Gain
0	1x xxxx	01 1111	–46.5 dB Gain	Not Applicable
1	xx xxxx	xx xxxx	Muted	Muted

Table 37. Surround Volume Control Register (Index 38h)

Reg No.	Name	D15	D14	D13 ¹	D12	D11	D10	D9	D8	D7	D6	D5 ¹	D4	D3	D2	D1	D0	Default
38h	Surround Volume	MUTE_L	X	LSR5	LSR4	LSR3	LSR2	LSR1	LSR0	MUTE_R	X	RSR5	RSR4	RSR3	RSR2	RSR1	RSR0	8080h

¹ Refer to Table 37 for examples. This register controls the surround volume controls for both stereo channels and mute bits. Each volume subregister contains five bits, generating 32 volume levels with 31 steps of 1.5 dB each. Because AC '97 defines 6-bit volume registers, to maintain compatibility, whenever the D5 or D13 Bit is set to 1, its respective lower five volume bits are automatically set to 1 by the coded logic. On readback, all lower five bits will read 1s whenever these bits are set to 1.

Note that depending on the state of the AC97NC bit in Register 76h, this register operates as follows:

For AC97NC = 0, the register controls the surround output pin attenuators. Range is 0 dB to –46.5 dB.

For AC97NC = 1, the register controls the surround DAC gain/attenuators. Range is +12 dB to –34.5 dB.

RSR[5:0]	Right Surround Volume Control
MUTE_R	Right Surround Volume Mute. When this bit is set to 1, the right channel is muted.
LSR[5:0]	Left Surround Volume Control
MUTE_L	Left Surround Volume Mute. When this bit is set to 1, the left channel is muted.

AD1888

Table 38. Settings for Surround Register

Control Bits Surround Volume (38h)				
D15/D7	Left Surround D[13:8]		Function with AC97NC = 0	Function with AC97NC = 1
	Right Surround D[5:0]			
	WRITE	READBACK		
0	00 0000	00 0000	0 dB Gain	12 dB Gain
0	00 1111	00 1111	-22 dB Gain	-10.5 dB Gain
0	01 1111	01 1111	-46.5 dB Gain	-34.5 dB Gain
0	1x xxxx	01 1111	-46.5 dB Gain	Not Applicable
1	xx xxxx	xx xxxx	Muted	Muted

Table 39. SPDIF Control Register (Index 3Ah)

Reg No.	Name	D15	D14	D13	D12	D11	D10	D9	D8	D7	D6	D5	D4	D3	D2	D1	D0	Default
3Ah	SPDIF Control	V	X	SPSR1	SPSR0	L	CC6	CC5	CC4	CC3	CC2	CC1	CC0	PRE	COPY	/AUD	PRO	2000h

All registers not shown and bits containing an X are assumed to be reserved.

Register 3Ah is a read/write register that controls SPDIF functionality and manages bit fields propagated as channel status (or subframe in the V case). With the exception of V, this register should only be written to when the SPDIF transmitter is disabled (SPDIF Bit in Register 2Ah is 0). This ensures that control and status information starts up correctly at the beginning of SPDIF transmission.

PRO	Professional. 1 indicates professional use of channel status, 0 indicates consumer.
/AUD	Non-Audio. 1 indicates data is non PCM format, 0 indicates data is PCM.
COPY	Copyright. 1 indicates copyright is asserted, 1 indicates copyright is not asserted.
PRE	Pre-emphasis. 1 indicates filter pre-emphasis is 50 μ s/15 μ s, 0 indicates pre-emphasis is none.
CC[6-0]	Category Code. Programmed according to IEC standards, or as appropriate.
L	Generation Level. Programmed according to IEC standards, or as appropriate.
SPSR[1,0]	SPDIF Transmit Sample Rate: SPSR[1:0] = 00 Transmit Sample Rate = 44.1 kHz SPSR[1:0] = 01 Reserved SPSR[1:0] = 10 Transmit Sample Rate = 48 kHz (default) SPSR[1:0] = 11 Not supported.
V	Validity. This bit affects the Validity flag (Bit 28 transmitted in each SPDIF L/R subframe) and enables the SPDIF transmitter to maintain connection during error or mute conditions. V = 1 Each SPDIF subframe (L + R) has Bit 28 set to 1. This tags both samples as invalid. V = 0 Each SPDIF subframe (L + R) has Bit 28 set to 0 for valid data and 1 for invalid data (error condition). Note that when V = 0, asserting the VFORCE bit (D15) in Register 2Ah (Ext'd Audio Stat/Ctrl) will force the Validity flag low, marking both samples as valid.

Table 40. Jack Sense/Audio Interrupt Status Register (Index 72h)

Reg No.	Name	D15	D14	D13	D12	D11	D10	D9	D8	D7	D6	D5	D4	D3	D2	D1	D0	Default
72h	Jack Sense	JS1 SPRD	JS1 DMX	JS0 DMX	JS MT2	JS MT1	JS MT0	X	X	JS1 TMR	JS0 TMR	JS1 MD	JS0 MD	JS1 ST	JS0 ST	JS1 INT	JS0 INT	0000h

All register bits are read/write except for JS0ST and JS1ST, which are read only.

JS0INT	Indicates Pin JS0 has generated an interrupt. Remains set until the software services JS0 interrupt, i.e., JS0 ISR should clear this bit by writing a 0 to it. Note that the interrupt to the system is actually an OR combination of this bit and JS1INT. Also, note that the actual interrupt implementation is selected by the INTS bit (Register 76h). It is also possible to generate a software system interrupt by writing a 1 to this bit.
JS1INT	Indicates Pin JS1 has generated an interrupt. Remains set until the software services JS1 interrupt, i.e., JS1 ISR should clear this bit by writing a 0 to it. See the JS0INT description for additional details.
JS0ST	JS0 STATE. This bit always reports the logic state of the JS0 pin.
JS1ST	JS1 STATE. This bit always reports the logic state of the JS1 pin.
JS0MD	JS0 Mode. This bit selects the operation mode for the JS0 pin. 0 = Jack Sense Mode (reset default) 1 = Interrupt Mode
JS1MD	JS1 Mode. This bit selects the operation mode for the JS1 pin. 0 = Jack Sense Mode (reset default) 1 = Interrupt Mode
JS0TMR	JS0 Timer Enable. If this bit is set to a 1, JS0 must be high for greater than 278 ms to be recognized.
JS1TMR	JS1 Timer Enable. If this bit is set to a 1, JS1 must be high for greater than 278 ms to be recognized.
JSMT[2,0]	JS Mute Enable Selector. These three bits select and enable the Jack Sense muting action (see Table 41).
JS0DMX	JS0 Down Mix Control Enable. This bit enables JS0 to control the down-mix function. This function allows a digital mix of six channels of audio into 2-channel audio. The mix can then be routed to the stereo Line_OUT or HP_OUT jacks. When this bit is set to 1, JS0 = 1 will activate the down-mix conversion. See the DMIX description in Register 76h. The DMIX bits select the down-mix implementation type and can also force the function to be activated.
JS1DMX	JS1 Down Mix Control Enable. This bit enables 2-channel to 6-channel audio spread function when both Jack Senses are active (logic state 1). Note that the SPRD bit can also force the spread function without being gated by the Jack Senses. See this bit's description in Register 76h for a better understanding of the spread function.
JS1SPRD	JS Spread Control Enable. This bit enables 2-channel to 6-channel audio spread function when both Jack Senses are active (logic state 1). Note that the SPRD bit can also force the spread function without being gated by the Jack Senses. See this bit's description in Register 76h for a better understanding of the spread function.

AD1888

Table 41. Jack Sense Mute Select (JSMT [2:0])

JS1	JS0	JSMT2	JSMT1	JSMT0	HP OUT	LINE OUT	C/LFE OUT	MONO OUT	Notes
NA	NA	0	0	0	ACTIVE	ACTIVE	ACTIVE	ACTIVE	JS0 and JS1 ignored.
OUT (0)	OUT (0)	0	0	1	ACTIVE	FMUTE	FMUTE	ACTIVE	JS0 no mute action, JS1 mutes mono and enables LINE_OUT and C/LFE. Standard 6-channel config.
OUT (0)	IN (1)	0	0	1	ACTIVE	FMUTE	FMUTE	ACTIVE	
IN (1)	OUT (0)	0	0	1	ACTIVE	ACTIVE	ACTIVE	ACTIVE	
IN (1)	IN (1)	0	0	1	ACTIVE	ACTIVE	ACTIVE	ACTIVE	
OUT (0)	OUT (0)	1	0	0	ACTIVE	FMUTE	FMUTE	ACTIVE	JS0 = 0 and JS1 = 0 enables mono. JS1 = 1 enables front only JS0 = 1 enables all rear. 6-chan config with front jack wrapback.
OUT (0)	IN (1)	1	0	0	ACTIVE	ACTIVE	ACTIVE	FMUTE	
IN (1)	OUT (0)	1	0	0	ACTIVE	FMUTE	FMUTE	FMUTE	
IN (1)	IN (1)	1	0	0	ACTIVE	FMUTE	FMUTE	FMUTE	
OUT (0)	OUT (0)	1	0	1	FMUTE	FMUTE	FMUTE	ACTIVE	JS0 no mute action, JS1 mutes mono and enables LINE_OUT + HP_OUT + C/LFE. Standard 6-channel config.
OUT (0)	IN (1)	1	0	1	FMUTE	FMUTE	FMUTE	FMUTE	
IN (1)	OUT (0)	1	0	1	ACTIVE	ACTIVE	ACTIVE	FMUTE	
IN (1)	IN (1)	1	0	1	ACTIVE	ACTIVE	ACTIVE	FMUTE	
NA	NA	1	1	0	**	**	**	**	** Reserved
NA	NA	1	1	1	**	**	**	**	** Reserved
NA	NA	0	1	1	**	**	**	**	** Reserved

FMUTE = Output is forced to mute independent of the respective Volume register setting.
 ACTIVE = Output is not muted and its status is dependent on the respective Volume register setting.
 OUT = Nothing plugged into the jack and therefore the JS status is 0 (via the load resistor pull-down).
 IN = Jack has plug inserted and therefore the JS status is 1 (via the codec JS internal pull-up).

Table 42. Serial Configuration Register (Index 74h)

Reg No.	Name	D15	D14	D13	D12	D11	D10	D9	D8	D7	D6	D5	D4	D3	D2	D1	D0	Default
74h	Serial Config	SLOT16	REGM2	REGM1	REGM0	REGM3	DRF	X	CHEN	X	LBKS1	LBKS0	INTS	X	SPAL	SPDZ	SPLNK	1001h
SPLNK	SPDIF Link. This bit enables the SPDIF to link with the front DACs for data requesting. 0 = SPDIF and DAC are not linked. 1 = SPDIF and DAC are linked and receive the same data requests (reset default).																	
SPDZ	SPDIF DACZ. 0 = Repeat last sample out of the SPDIF stream if FIFO underruns (reset default). 1 = Forces midscale sample out the SPDIF stream if FIFO underruns.																	
SPAL	SPDIF ADC Loop-Around. 0 = SPDIF transmitter is connected to the AC-Link stream (reset default). 1 = SPDIF transmitter is connected to the digital ADC stream, not the AC-Link.																	
INTS	Interrupt Mode Select. This bit selects the JS interrupt implementation path. 0 = Bit 0 SLOT 12 (modem interrupt) (reset default). 1 = Slot 6 Valid Bit (MIC ADC interrupt).																	
LBKS[1:0]	Loop-Back Selection. These bits select the internal digital loop-back path when LPBK bit is active (see Register 20h) 00 = Loop-back through the front DACs (reset default). 01 = Loop-back through the surround DACs. 10 = Reserved 11 = Loop-back through the center and LFE DACs (center DAC loops back from the ADC left channel, the LFE DAC from the ADC right channel).																	
CHEN	Chain Enable. This bit enables chaining of a slave codec SDATA_IN stream into the ID0 pin (Pin 45). 0 = Disable chaining (reset default). 1 = Enable chaining into ID0 pin.																	
DRF	DAC Request Force. This allows the AD1888 to synchronize DAC requests with the AD1981A/B. 0 = Normal DAC requesting sequence (reset default). 1 = Synchronize to AD1981A/B DAC requests.																	
REGM3	Slave 3 Codec Register Mask																	
REGM0	Master Codec Register Mask																	
REGM1	Slave 1 Codec Register Mask																	
REGM2	Slave 2 Codec Register Mask																	
SLOT16	Enable 16-Bit Slot Mode. SLOT16 makes all ac-link slots 16 bits in length, formatted into 16 slots. This is a preferred mode for DSP serial port interfacing.																	

AD1888

Table 43. Miscellaneous Control Bit Register (Index 76h)

Reg No.	Name	D15	D14	D13	D12	D11	D10	D9	D8	D7	D6	D5	D4	D3	D2	D1	D0	Default
76h	Misc Control Bits	DACZ	AC97NC	MSPLT	LODIS	CLDIS	HPSEL	DMIX1	DMIX0	SPRD	X	LOSEL	SRU	VREFH	VREFD	MBG1	MBG0	0000h

MBG[1:0]	<p>MIC Boost Gain Select Register. These two bits allow changing the MIC preamp gain from the nominal 20 dB gain. Both MIC1/MIC2 and MIC2 preamps will be set to the same selected gain. Note that this gain takes effect only while Bit D6 (M20) on the MIC volume register (0Eh) is set to 1; otherwise, the MIC boost block has a gain of 0 dB.</p> <p>00 = 20 dB gain (reset default) 01 = 10 dB gain 10 = 30 dB gain 11 = reserved</p>
VREFD	<p>V_{REFOUT} Disable. Disables V_{REFOUT}, placing it into High-Z out mode. Note that this bit overrides the VREFH bit selection (see below).</p> <p>0 = V_{REFOUT} pin is driven by the internal reference (reset default). 1 = V_{REFOUT} pin is placed into High-Z out mode.</p>
VREFH	<p>V_{REFOUT} High. Changes V_{REFOUT} from 2.25 V to 3.70 V for PC2001 compliant MIC bias applications.</p> <p>0 = V_{REFOUT} pin is set to 2.25 V output (reset default). 1 = V_{REFOUT} pin is set to 3.70 V output.</p>
SRU	<p>Sample Rate Unlock. Controls DAC sample rate locking.</p> <p>0 = All DAC sample rates are locked to the front sample rate (reset default) 1 = DAC sample rates can be set independently for front, surround, and LFE.</p>
LOSEL	<p>LINE_OUT Amplifiers Input Select. This bit allows the LINE_OUT output amplifiers to be driven by the mixer or the surround DACs. The main purpose for this is to allow swapping of the front and surround channels to make better use of the SURR/HP_OUT output amplifiers. This bit should normally be used in tandem with the HPSEL bit (see below).</p> <p>0 = LINE_OUT amplifiers are driven by the mixer outputs (reset default). 1 = LINE_OUT amplifiers are driven by the surround DAC outputs.</p>
SPRD	<p>SPREAD Enable. This bit enables spreading of 2-channel media to all six output channels. This function is implemented in the analog section by using the output selector controls line for the center/LFE, surround, and Line_out output channels. Note that the Jack Sense pins can also be set up to control (gate) this function, depending on the JSSPRD bit (see Register 72h).</p> <p>0 = No spreading occurs unless activated by the Jack Senses and JSSPRD bits (reset default). 1 = The SPRD selector drives the center and LFE outputs from the MONO_OUT, the HPSEL selector drives the SURR/HP_OUT outputs from the mixer outputs, and the LOSEL selector drives the LINE_OUT outputs also from the mixer outputs.</p> <p>Note that the SPRD bit overrides the current output selector control lines set up by bits LOSEL and HPSEL as follows: LOSEL = 0 and HPSEL = 1.</p>

DMIX[1:0]	<p>Down Mix Mode Select. Provides analog down-mixing of the center, LFE, and/or surround channels into the mixer channels. This allows the full content of 5.1 or quad media to be played through stereo headphones or speakers.</p> <p>Note that the Jack Sense pins can also be set up to control (gate) this function depending on the JS0DMX and JS1DMX Bits (see Register 72h).</p> <p>The upper bit allows forcing the down-mix function: DMIX[1] = 0, no down-mix unless activated by the Jack Sense and JSxDMX bits (default). DMIX[1] = 1, forces down-mix function.</p> <p>The lower bit selects the down-mix type: DMIX[0] = 0, selects 6-to-4 down-mix. The center and LFE channels are summed equally into the mixer left and right channels (default). DMIX[0] = 1, selects 6-to-2 down-mix. The surround left and right channels are summed into the mixer left and right channels. Default for DMIX[1:0] is 00.</p>
HPSEL	<p>Headphone Amplifier Input Select. This bit allows the headphone power amps to be driven from the surround DACs or from the mixer outputs. There are two reasons for this: one is to allow 2-channel media to use the higher power headphone amplifiers available on the SURR/HP_OUT outputs; the other is to allow spreading of 2-channel media to the surround outputs. Together with the LOSEL bit (see above), this bit also provides for analog swapping of the mixer (front) and surround outputs.</p> <p>0 = SURR_OUT/HP_OUT outputs are driven by the surround DACs (reset default). 1 = SURR_OUT/HP_OUT outputs are driven by the mixer outputs.</p>
CLDIS	<p>Center and LFE Disable. Disables the center and LFE output pins, placing them into High-Z mode so that the assigned output audio jack(s) can be shared for MIC inputs or other functions.</p> <p>0 = Center and LFE output pins have normal audio drive capability (reset default). 1 = Center and LFE output pins are placed into High-Z mode.</p>
LODIS	<p>Line_out Disable. Disables the Line_out pins (L/R), placing them into High-Z mode so that the assigned output audio jack can be shared for Line Input function.</p> <p>0 = Line_out pins have normal audio drive capability (reset default). 1 = Line_out pins are placed into High-Z mode.</p>
MSPLT	<p>Mute Split. Allows separate mute control bits for master, HP, Line_in, CD, PCM OUT, and record volume/gain control registers.</p> <p>0 = Both left and right channel mutes are controlled by Bit D15 in the respective registers (reset default). 1 = Bit D15 affects only the left channel mute and Bit D7 affects only the right channel mute.</p>
AC97NC	<p>AC '97 No Compatibility Mode. This bit allows the surround, center, and LFE volume control registers and output attenuators to operate in a more functional mode than defined by the AC97 2.2 spec. This is called ADI compatibility mode.</p> <p>In AC '97 compatibility mode, the DAC gain/attenuators for the surround, center, and LFE are controlled by Register 18h (PCM volume). The output pin attenuators for the surround are controlled by Register 38h, and the output pin attenuators for the center and LFE are controlled by Register 36h.</p> <p>In ADI compatibility mode, the Surround DAC gain/attenuators are controlled by Register 38h, and the Center/LFE DACs are controlled by Register 36h.</p> <p>The output pin attenuators for Center/LFE are controlled by Register 02h (Master Volume), and the output pin attenuators for Surround are controlled by Register 04h.</p> <p>0 = AC97 compatibility mode (reset default). 1 = ADI compatibility mode.</p>
DACZ	<p>DAC Zero-Fill. Determines DAC data fill under starved condition.</p> <p>0 = DAC data is repeated when DACs are starved for data (reset default). 1 = DAC data is zero-filled when DACs are starved for data.</p>

AD1888

Table 44. Vendor ID Register (Index 7Ch–7Eh)

Reg No.	Name	D15	D14	D13	D12	D11	D10	D9	D8	D7	D6	D5	D4	D3	D2	D1	D0	Default
7Ch	Vendor ID1	F7	F6	F5	F4	F3	F2	F1	F0	S7	S6	S5	S4	S3	S2	S1	S0	4144h

S[7:0] This register is ASCII encoded to A.

F[7:0] This register is ASCII encoded to D.

Reg No.	Name	D15	D14	D13	D12	D11	D10	D9	D8	D7	D6	D5	D4	D3	D2	D1	D0	Default
7Eh	Vendor ID2	T7	T6	T5	T4	T3	T2	T1	T0	REV7	REV6	REV5	REV4	REV3	REV2	REV1	REV0	5368h

T[7:0] This register is ASCII encoded to S.

REV[7:0] This register is set to 68h identifying the AD1888.

Table 45. Codec ID and Clock Selection Table

XTL_IN	ID1#	ID0#	Codec ID	Codec Clocking Source
GND	0	0	SECONDARY, ID = 3	12.288 MHz (BIT_CLK from Primary Codec)
GND	0	1	SECONDARY, ID = 2	12.288 MHz (BIT_CLK from Primary Codec)
GND	1	0	SECONDARY, ID = 1	12.288 MHz (BIT_CLK from Primary Codec)
XTAL into XTL_IN	1	1	PRIMARY, ID = 0	24.576 MHz Local XTAL or External CLK
CLK INPUT	0	0	PRIMARY, ID = 0	14.3181 MHz (External into XTL_IN)
CLK INPUT	0	1	PRIMARY, ID = 0	48.00 MHz (External into XTL_IN)
CLK INPUT	1	X	RESERVED	RESERVED

Note that internally, the \overline{ID} pins have weak pull-ups and are inverted.

AD1888

NOTES

Looking for pricing, stock, or lifecycle information?

Click below to explore more details on WIN SOURCE:

-  [View AD1888JST-REEL on WIN SOURCE](#)
-  [Analog Devices Inc. Information](#)

Optimize Your Supply Chain with WIN SOURCE Solutions

-  Global Sourcing Solution
-  Obsolete Management
-  Cost Control Management
-  Shortage Management
-  Alternative Solution
-  Excess Inventory Management