

## Features

- Pulse-width Modulation up to 2-kHz Clock Frequency
- Protection Against Short-circuit, Load-dump Overvoltage and Reverse  $V_S$
- Duty Cycle 0% to 100% Continuously
- Output Stage for Power MOSFET
- Interference and Damage Protection According to VDE 0839 and ISO/TR 7637/1
- Charge-pump Noise Suppressed
- Ground-wire Breakage Protection



## PWM Power Control with Automatic Duty-cycle Reduction

### 1. Description

The U6084B is a PWM-IC with bipolar technology designed for the control of an N-channel power MOSFET used as a high-side switch. The IC is ideal for use in the brightness control (dimming) of lamps such as in dashboard applications. For constant brightness, the preselected duty cycle can be reduced automatically as a function of the supply voltage.

### U6084B

Figure 1-1. Block Diagram with External Circuit

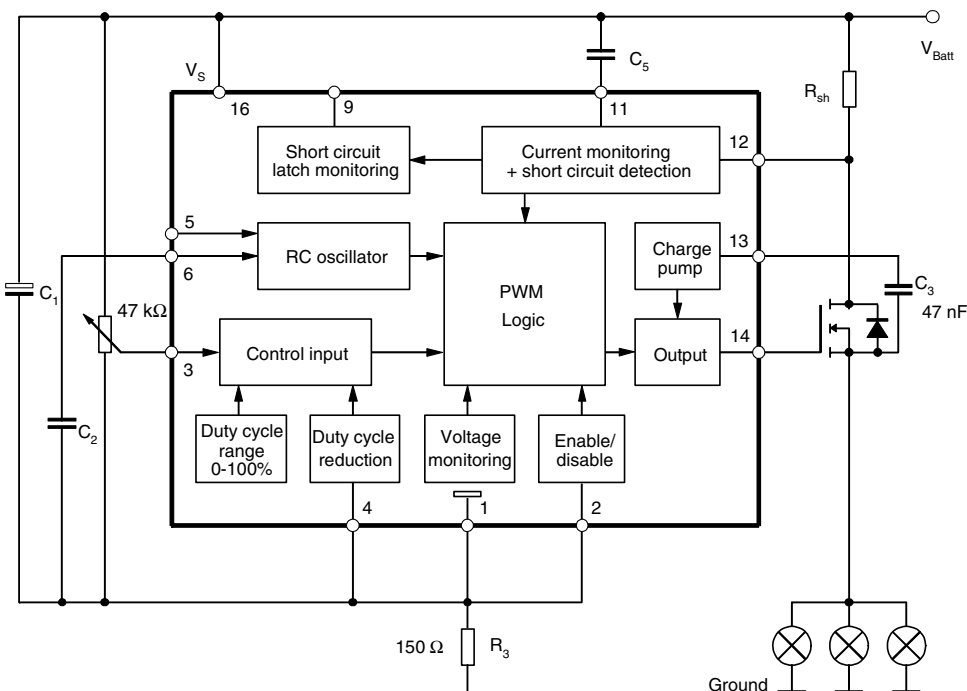

## 2. Pin Configuration

Figure 2-1. Pinning SO16

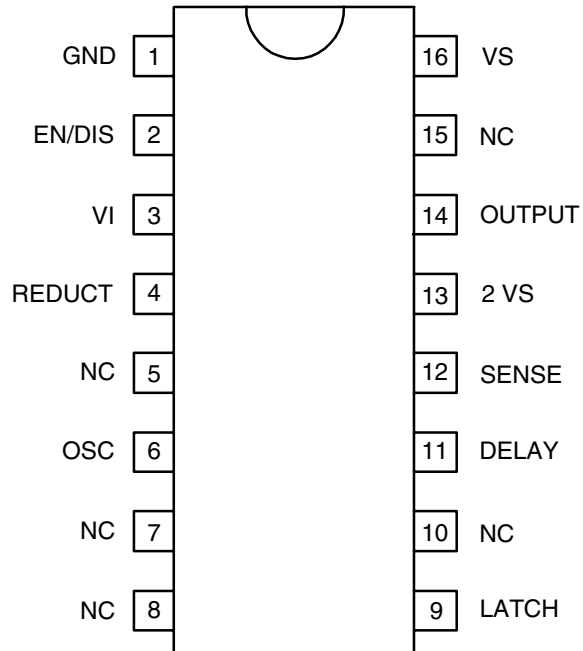

Table 2-1. Pin Description

Pin	Symbol	Function
1	GND	IC ground
2	EN/DIS	Enable/disable
3	VI	Control input (duty cycle)
4	REDUCT	Duty cycle reduction
5	NC	Attenuation
6	OSC	Oscillator
7	NC	Not connected
8	NC	Not connected
9	LATCH	Status short-circuit latch
10	NC	Not connected
11	DELAY	Short-circuit protection delay
12	SENSE	Current sensing
13	2VS	Voltage doubler
14	OUTPUT	Output
15	NC	Not connected
16	VS	Supply voltage $V_S$

### 3. Functional Description

#### 3.1 Pin1 – GND

##### 3.1.1 Ground-wire Breakage

To protect the FET in case of ground-wire breakage, a 820-kΩ resistor between gate and source is recommended to provide proper switch-off conditions.

#### 3.2 Pin 2 – Enable/Disable

The dimmer can be switched on or off with pin 2, independently of the set duty cycle.

**Table 3-1.** Pin 2 Function

V <sub>2</sub>	Function
> approximately 0.7V or open	Disable
< 0.7V or connected to pin 1	Enable

#### 3.3 Pin 3 – Control Input

The pulse width is controlled by means of an external potentiometer (47 kΩ). The characteristic (angle of rotation/duty cycle) is linear. The duty cycle be varied from 0% to 100%. It is possible to further restrict the duty cycle with resistors R<sub>1</sub> and R<sub>2</sub> (Figure 7-1 on page 9).

Pin 3 is protected against short-circuit to V<sub>Batt</sub> and ground GND (V<sub>Batt</sub> ≤16.5V).

#### 3.4 Pin 4 – Duty Cycle Reduction

With pin 4 connected according to Figure 7-1 on page 9, the set duty cycle is reduced to V<sub>Batt</sub> ≈ 12.5V. This causes a power reduction in the FET and in the lamps. In addition, the brightness of the lamps is largely independent of the supply voltage range, V<sub>Batt</sub> = 12.5V to 16V.

##### 3.4.1 Output Slope Control

The rise and fall time (t<sub>r</sub>, t<sub>f</sub>) of the lamp voltage can be limited to reduce radio interference. This is done with an integrator which controls a power MOSFET as source follower. The slope time is controlled by an external capacitor C<sub>4</sub> and the oscillator current (Figure 7-1 on page 9).

Calculation:

$$t_f = t_r = V_{Batt} \times \frac{C_4}{I_{osc}}$$

With V<sub>Batt</sub> = 12V, C<sub>4</sub> = 470 pF and I<sub>osc</sub> = 40 μA, the controlled slope is

$$t_f = t_r = 12V \times \frac{470 \text{ pF}}{40 \text{ μA}} \times 141 \text{ μs}$$

#### 3.5 Pin 5 – Attenuation

Capacitor C<sub>4</sub> connected to pin 5 damps oscillation tendencies.

### 3.6 Pin 6 – Oscillator

The oscillator determines the frequency of the output voltage. This is defined by an external capacitor,  $C_2$ . It is charged with a constant current,  $I$ , until the upper switching threshold is reached. A second current source is then activated which taps a double current,  $2 \times I$ , from the charging current. The capacitor,  $C_2$ , is thus discharged by the current,  $I$ , until the lower switching threshold is reached. The second source is then switched off again and the procedure starts once more.

#### 3.6.1 Example for Oscillator Frequency Calculation

$$V_{T100} = V_S \times \alpha_1 = (V_{Batt} - I_S \times R_3) \times \alpha_1$$

$$V_{T<100} = V_S \times \alpha_2 = (V_{Batt} - I_S \times R_3) \times \alpha_2$$

$$V_{TL} = V_S \times \alpha_3 = (V_{Batt} - I_S \times R_3) \times \alpha_3$$

where

$V_{T100}$  = High switching threshold 100% duty cycle

$V_{T<100}$  = High switching threshold < 100% duty cycle

$V_{TL}$  = Low switching threshold

$\alpha_1$ ,  $\alpha_2$  and  $\alpha_3$  are fixed values

The above mentioned threshold voltages are calculated for the following values given in the datasheet.

$$V_{Batt} = 12V, I_S = 4 \text{ mA}, R_3 = 150\Omega$$

$$\alpha_1 = 0.7, \alpha_2 = 0.67 \text{ and } \alpha_3 = 0.28$$

$$V_{T100} = (12V - 4 \text{ mA} \times 150\Omega) \times 0.7 \approx 8V$$

$$V_{T<100} = 11.4V \times 0.67 = 7.6V$$

$$V_{TL} = 11.4V \times 0.28 = 3.2V$$

For a duty cycle of 100%, the oscillator frequency,  $f$ , is as follows:

$$f = \frac{I_{osc}}{2 \times (V_{T100} - V_{TL}) \times C_2} \text{ where } C_2 = 22 \text{ nF and } I_{osc} = 40 \mu A$$

Therefore:

$$f = \frac{40 \mu A}{2 \times (8V - 3.2V) \times 22 \text{ nF}} = 189\text{Hz}$$

For a duty cycle of less than 100%, the oscillator frequency,  $f$ , is as follows:

$$f = \frac{I_{osc}}{2 \times (V_{T<100} - V_{TL}) \times C_2 + 4 \times V_{Batt} \times C_4}$$

where  $C_4 = 470 \text{ pF}$

$$f = \frac{40 \mu A}{2 \times (7.6V - 3.2V) \times 22 \text{ nF} + 4 \times 12V \times 470 \text{ pF}} = 185\text{Hz}$$

A selection of different values of  $C_2$  and  $C_4$  provides a range of oscillator frequencies from 10Hz to 2000Hz.

### 3.7 Pins 7, 8, 10 and 15

Not connected.

### 3.8 Pin 9 – Status Short Circuit Latch

The status of the short-circuit latch can be monitored via pin 9 (open collector output).

**Table 3-2.** Pin 9 Function

Pin 9	Function
L	Short-circuit detected
H	No short-circuit detected

### 3.9 Pins 11 and 12 – Short-circuit Protection and Current Sensing

#### 3.9.1 Short-circuit Detection and Time Delay $t_d$

The lamp current is monitored by means of an external shunt resistor. If the lamp current exceeds the threshold for the short-circuit detection circuit ( $V_{T2} \approx 90$  mV), the duty cycle is switched over to 100% and capacitor  $C_5$  is charged by a current source of  $20 \mu\text{A}$  ( $I_{ch} - I_{dis}$ ). The external FET is switched off after the cut-off threshold ( $V_{T11}$ ) is reached. Renewed switching on of the FET is possible only after a power-on reset. The current source,  $I_{dis}$ , ensures that capacitor  $C_5$  is not charged by parasitic currents. Capacitor  $C_5$  is discharged by  $I_{dis}$  to typically 0.7V.

Time delay,  $t_d$ , is as follows:

$$t_d = C_5 \times \frac{(V_{T11} - 0.7V)}{(I_{ch} - I_{dis})}$$

With  $C_5 = 330$  nF and  $V_{Batt} = 12V$ , we have

$$t_d = 330 \text{ nF} \times \frac{(9.8V - 0.7V)}{20 \mu\text{A}} = 150 \text{ ms}$$

#### 3.9.2 Current Limitation

The lamp current is limited by a control amplifier that protects the external power transistor. The voltage drop across an external shunt resistor acts as the measured variable. Current limitation takes place for a voltage drop of  $V_{T1} \approx 100$  mV. Owing to the difference  $V_T - V_{T2} \approx 10$  mV, current limitation occurs only when the short-circuit detection circuit has responded.

After a power-on reset, the output is inactive for half an oscillator cycle. During this time, the supply voltage capacitor can be charged so that current limitation is guaranteed in the event of a short-circuit when the IC is switched on for the first time.

### 3.10 Pins 13 and 14 – Charge Pump and Output

Pin 14 (output) is suitable for controlling a power MOSFET. During the active integration phase, the supply current of the operational amplifier is mainly supplied by capacitor  $C_3$  (bootstrapping). Additionally, a trickle charge is generated by an integrated oscillator ( $f_{13} \approx 400$  kHz) and a voltage doubler circuit. This permits a gate voltage supply at a duty cycle of 100%.

### 3.11 Pin 16 – Supply Voltage, $V_s$ or $V_{Batt}$

#### 3.11.1 Undervoltage Detection

In the event of voltages of approximately  $V_{Batt} < 5.0V$ , the external FET is switched off and the latch for short-circuit detection is reset.

A hysteresis ensures that the FET is switched on again at approximately  $V_{Batt} \geq 5.4V$ .

#### 3.11.2 Overvoltage Detection

- Stage 1
  - If overvoltages of  $V_{Batt} > 20V$  (typically) occur, the external transistor is switched off and switched on again at  $V_{Batt} < 18.5V$  (hysteresis).
- Stage 2
  - If  $V_{Batt} > 28.5V$  (typically), the voltage limitation of the IC is reduced from 26V to 20V. The gate of the external transistor remains at the potential of the IC ground, thus producing voltage sharing between the FET and lamps in the event of overvoltage pulses (for example, load dump). The short-circuit protection is not in operation. At  $V_{Batt} < 23V$ , the overvoltage detection stage 2 is switched off.

## 4. Absolute Maximum Ratings

Stresses beyond those listed under “Absolute Maximum Ratings” may cause permanent damage to the device. This is a stress rating only and functional operation of the device at these or any other conditions beyond those indicated in the operational sections of this specification is not implied. Exposure to absolute maximum rating conditions for extended periods may affect device reliability

Parameters	Symbol	Value	Unit
Junction temperature	$T_j$	150	°C
Ambient temperature range	$T_{amb}$	-40 to +110	°C
Storage temperature range	$T_{stg}$	-55 to +125	°C

## 5. Thermal Resistance

Parameters	Symbol	Value	Unit
Junction ambient	$R_{thJA}$	120	K/W

## 6. Electrical Characteristics

$T_{amb} = -40$  to  $+110^\circ\text{C}$ ,  $V_{Batt} = 9\text{V}$  to  $16.5\text{V}$  (basic function is guaranteed between  $6.0\text{V}$  and  $9.0\text{V}$ ), reference point ground, unless otherwise specified (Figure 1-1 on page 1). All other values refer to pin GND (pin 1).

Parameters	Test Conditions	Symbol	Min.	Typ.	Max.	Unit
Current consumption	Pin 16	$I_S$			6.8	mA
Supply voltage	Oversvoltage detection, stage 1	$V_{Batt}$			25	V
Stabilized voltage	$I_S = 10\text{ mA}$ , pin 16	$V_S$	24.5		27.0	V
Battery undervoltage detection	- On	$V_{Batt}$	4.4	5.0	5.6	V
	- Off		4.8	5.4	6.0	
<b>Battery Oversvoltage Detection Pin 2</b>						
Stage 1:	- On	$V_{Batt}$	18.3	20.0	21.7	V
	- Off		16.7	18.5	20.3	
Stage 2:	- On	$V_{Batt}$	25.5	28.5	32.5	V
	- Off		19.5	23.0	26.5	
Stabilized voltage	$I_S = 30\text{ mA}$ , pin 16	$V_Z$	18.5	20.0	21.5	V
<b>Short-circuit Protection Pin 12</b>						
Short-circuit current limitation	$V_{T1} = V_S - V_{12}$	$V_{T1}$	85	100	120	mV
Short-circuit detection	$V_{T2} = V_S - V_{12}$	$V_{T2}$	75	90	105	mV
		$V_{T1} - V_{T2}$	3	10	30	mV
<b>Delay Timer Short-circuit Detection Pin 11</b>						
Switched off threshold	$V_{T11} = V_S - V_{11}$	$V_{T11}$	9.5	9.8	10.1	V
Charge current		$I_{ch}$		23		μA
Discharge current		$I_{dis}$		3		μA
Capacitance current	$I_5 = I_{ch} - I_{dis}$	$I_5$	13	20	27	mA
<b>Output Short-circuit Latch Pin 9</b>						
Saturation voltage	$I_9 = 100\text{ μA}$	$V_{sat}$		150	350	mV
<b>Voltage Doubler Pin 13</b>						
Voltage	Duty cycle 100%	$V_{13}$	$2 V_S$			
Oscillator frequency		$f_{13}$	280	400	520	kHz

Note: 1. Reference point is battery ground

## 6. Electrical Characteristics (Continued)

$T_{amb} = -40$  to  $+110^{\circ}\text{C}$ ,  $V_{Batt} = 9\text{V}$  to  $16.5\text{V}$  (basic function is guaranteed between  $6.0\text{V}$  and  $9.0\text{V}$ ), reference point ground, unless otherwise specified (Figure 1-1 on page 1). All other values refer to pin GND (pin 1).

Parameters	Test Conditions	Symbol	Min.	Typ.	Max.	Unit
Internal voltage limitation	$I_{13} = 5\text{ mA}$	$V_{13}$	26	27.5	30.0	V
	(Whichever is lower)	$V_{13}$	$(V_{S+14})$	$(V_{S+15})$	$(V_{S+16})$	
<b>Gate Output</b>		<b>Pin 14</b>				
Voltage	Low level	$V_{14}$	0.35	0.70	0.95	V
	$V_{Batt} = 16.5\text{V}$ , $T_{amb} = 110^{\circ}\text{C}$ , $R_3 = 150\Omega$				$1.5^{(1)}$	
	High level, duty cycle 100%	$V_{14}$		$V_{13}$		
Current	$V_{14} = \text{Low level}$	$I_{14}$	1.0			mA
	$V_{14} = \text{High level}$ , $I_{13} >  I_{14} $		-1.0			
<b>Enable/Disable</b>		<b>Pin 2</b>				
Current	$V_2 = 0\text{V}$	$I_2$	-20	-40	-60	$\mu\text{A}$
<b>Duty Cycle Reduction</b>		<b>Pin 4</b>				
Z-voltage	$I_4 = 500\ \mu\text{A}$	$V_4$	6.9	7.4	8.0	V
<b>Oscillator</b>						
Frequency	Pin 6	f	10		2000	Hz
Threshold cycle Upper	$V_{14} = \text{High}$ , $\alpha_1 = \frac{V_{T100}}{V_S}$	$\alpha_1$	0.68	0.7	0.72	
	$V_{14} = \text{Low}$ , $\alpha_2 = \frac{V_{T<100}}{V_S}$	$\alpha_2$	0.65	0.67	0.69	
Lower	$\alpha_3 = \frac{V_{TL}}{V_S}$	$\alpha_3$	0.26	0.28	0.3	
Oscillator current	$V_{Batt} = 1\text{V}$	$\pm I_{osc}$	26	40	54	$\mu\text{A}$
Frequency tolerance	$C_4$ open, $C_2 = 470\text{ nF}$ , duty cycle = 50%	f	6.0	9.9	13.5	Hz

Note: 1. Reference point is battery ground

## 7. Application

Figure 7-1. Application

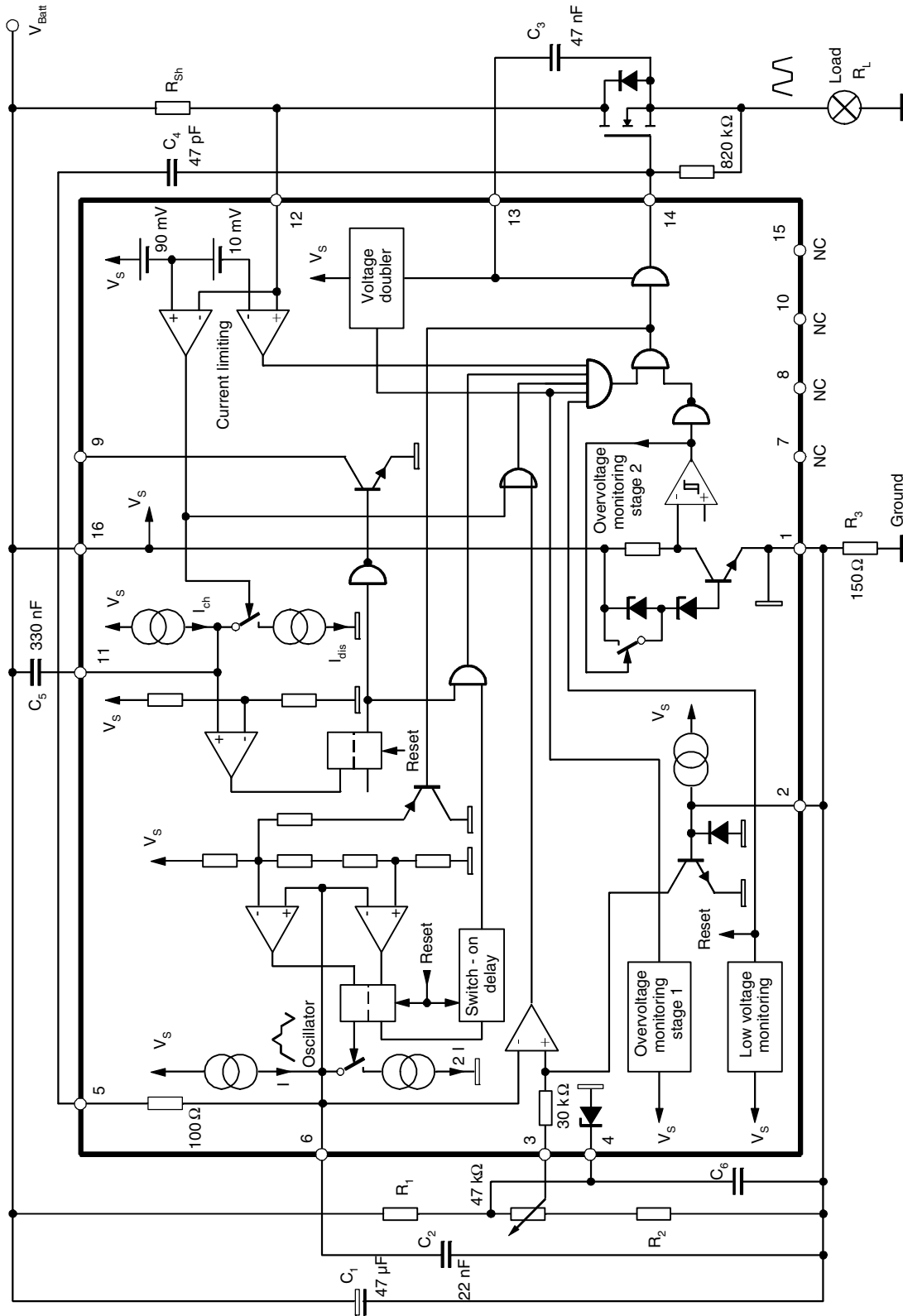

## 8. Ordering Information

Extended Type Number	Package	Remarks
U6084B-MFPG3Y	SO16	Taped and reeled, Pb-free

## 9. Package Information SO16

### Package SO16

Dimensions in mm

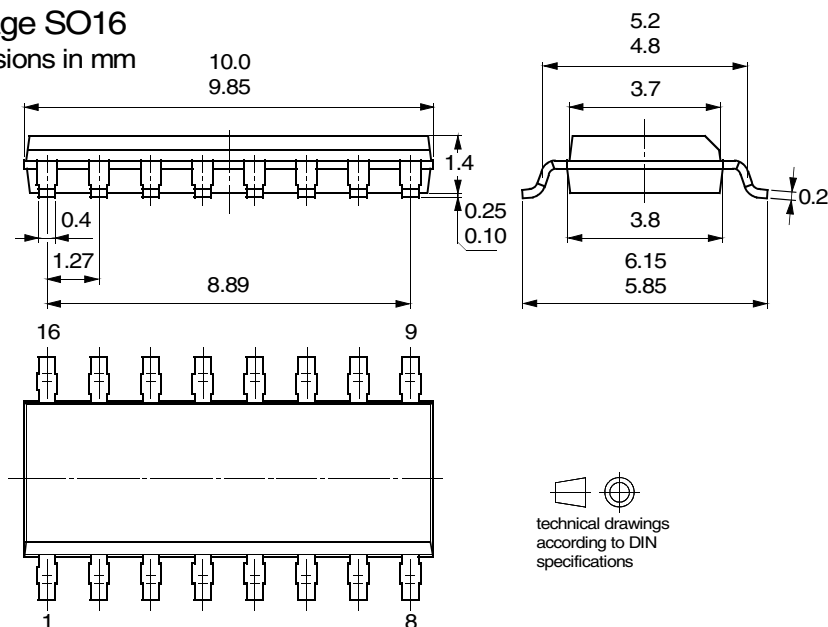

## 10. Revision History

Please note that the following page numbers referred to in this section refer to the specific revision mentioned, not to this document.

Revision No.	History
4677B-AUTO-02/03	<ul style="list-style-type: none"> <li>Block Diagram on Page 1 changed</li> <li>New heading rows at Table "Absolute Maximum Ratings" on page 6 added</li> </ul>
4677C-AUTO-08/05	<ul style="list-style-type: none"> <li>Put datasheet in a new template</li> <li>Updated text to new style guide</li> <li>First page: Pb-free logo added</li> <li>Page 9: Ordering Information changed</li> </ul>



## Atmel Corporation

2325 Orchard Parkway  
San Jose, CA 95131, USA  
Tel: 1(408) 441-0311  
Fax: 1(408) 487-2600

## Regional Headquarters

### Europe

Atmel Sarl  
Route des Arsenaux 41  
Case Postale 80  
CH-1705 Fribourg  
Switzerland  
Tel: (41) 26-426-5555  
Fax: (41) 26-426-5500

### Asia

Room 1219  
Chinachem Golden Plaza  
77 Mody Road Tsimshatsui  
East Kowloon  
Hong Kong  
Tel: (852) 2721-9778  
Fax: (852) 2722-1369

### Japan

9F, Tonetsu Shinkawa Bldg.  
1-24-8 Shinkawa  
Chuo-ku, Tokyo 104-0033  
Japan  
Tel: (81) 3-3523-3551  
Fax: (81) 3-3523-7581

## Atmel Operations

### Memory

2325 Orchard Parkway  
San Jose, CA 95131, USA  
Tel: 1(408) 441-0311  
Fax: 1(408) 436-4314

### Microcontrollers

2325 Orchard Parkway  
San Jose, CA 95131, USA  
Tel: 1(408) 441-0311  
Fax: 1(408) 436-4314

La Chantrerie  
BP 70602  
44306 Nantes Cedex 3, France  
Tel: (33) 2-40-18-18-18  
Fax: (33) 2-40-18-19-60

### ASIC/ASSP/Smart Cards

Zone Industrielle  
13106 Rousset Cedex, France  
Tel: (33) 4-42-53-60-00  
Fax: (33) 4-42-53-60-01

1150 East Cheyenne Mtn. Blvd.  
Colorado Springs, CO 80906, USA  
Tel: 1(719) 576-3300  
Fax: 1(719) 540-1759

Scottish Enterprise Technology Park  
Maxwell Building  
East Kilbride G75 0QR, Scotland  
Tel: (44) 1355-803-000  
Fax: (44) 1355-242-743

### RF/Automotive

Theresienstrasse 2  
Postfach 3535  
74025 Heilbronn, Germany  
Tel: (49) 71-31-67-0  
Fax: (49) 71-31-67-2340

1150 East Cheyenne Mtn. Blvd.  
Colorado Springs, CO 80906, USA  
Tel: 1(719) 576-3300  
Fax: 1(719) 540-1759

### Biometrics/Imaging/Hi-Rel MPU/ High Speed Converters/RF Datacom

Avenue de Rochepleine  
BP 123  
38521 Saint-Egreve Cedex, France  
Tel: (33) 4-76-58-30-00  
Fax: (33) 4-76-58-34-80

---

### Literature Requests

[www.atmel.com/literature](http://www.atmel.com/literature)

**Disclaimer:** The information in this document is provided in connection with Atmel products. No license, express or implied, by estoppel or otherwise, to any intellectual property right is granted by this document or in connection with the sale of Atmel products. **EXCEPT AS SET FORTH IN ATMEL'S TERMS AND CONDITIONS OF SALE LOCATED ON ATMEL'S WEB SITE, ATMEL ASSUMES NO LIABILITY WHATSOEVER AND DISCLAIMS ANY EXPRESS, IMPLIED OR STATUTORY WARRANTY RELATING TO ITS PRODUCTS INCLUDING, BUT NOT LIMITED TO, THE IMPLIED WARRANTY OF MERCHANTABILITY, FITNESS FOR A PARTICULAR PURPOSE, OR NON-INFRINGEMENT. IN NO EVENT SHALL ATMEL BE LIABLE FOR ANY DIRECT, INDIRECT, CONSEQUENTIAL, PUNITIVE, SPECIAL OR INCIDENTAL DAMAGES (INCLUDING, WITHOUT LIMITATION, DAMAGES FOR LOSS OF PROFITS, BUSINESS INTERRUPTION, OR LOSS OF INFORMATION) ARISING OUT OF THE USE OR INABILITY TO USE THIS DOCUMENT, EVEN IF ATMEL HAS BEEN ADVISED OF THE POSSIBILITY OF SUCH DAMAGES.** Atmel makes no representations or warranties with respect to the accuracy or completeness of the contents of this document and reserves the right to make changes to specifications and product descriptions at any time without notice. Atmel does not make any commitment to update the information contained herein. Unless specifically provided otherwise, Atmel products are not suitable for, and shall not be used in, automotive applications. Atmel's products are not intended, authorized, or warranted for use as components in applications intended to support or sustain life.

© Atmel Corporation 2005. All rights reserved. Atmel®, logo and combinations thereof, Everywhere You Are® and others, are registered trademarks or trademarks of Atmel Corporation or its subsidiaries. Other terms and product names may be trademarks of others.





Printed on recycled paper.

4677C-AUTO-09/05

## Looking for pricing, stock, or lifecycle information?

Click below to explore more details on WIN SOURCE:

-  [View U6084B-MFPG3 on WIN SOURCE](#)
-  [Microchip Technology Information](#)

## Optimize Your Supply Chain with WIN SOURCE Solutions

-  Global Sourcing Solution
-  Obsolete Management
-  Cost Control Management
-  Shortage Management
-  Alternative Solution
-  Excess Inventory Management