

*SST12LP19E is a versatile power amplifier based on the highly-reliable InGaP/GaAs HBT technology. SST12LP19E is a 2.4 GHz fully-integrated, high-power, high-gain Power Amplifier module designed in compliance with IEEE 802.11b/g/n and 256 QAM applications. For WLAN applications, it typically provides 25 dB gain with 34% power-added efficiency. SST12LP19E has excellent linearity while meeting 802.11g spectrum mask at 23.5 dBm and 802.11b spectrum mask at 23 dBm. This power amplifier includes a power detector with dB-wise linear voltage output and features easy board-level usage along with high-speed power-up/down control through a single combined reference voltage pin. SST12LP19E and is offered in 6-contact XSON, 8-contact XSON, and 6-contact X2SON packages. Due to its small package size and high efficiency, this power amplifier is also well suited for ZigBee® and Bluetooth® applications.*

## Features

- **Excellent RF Stability with Moderate Gain:**
  - Typically 25 dB gain across 2.4 – 2.5 GHz
- **High linear output power:**
  - >26 dBm P1dB
  - Please refer to “Absolute Maximum Stress Ratings” on page 6
  - Meets 802.11g OFDM ACPR requirement up to 23.5 dBm
  - 3% EVM up to 18 dBm (high-efficiency configuration) or ~3% EVM up to 19.5 dBm (high-power configuration) for 54 Mbps 802.11g signal
  - 2.5% EVM up to 16.5 dBm for MCS7–20 MHz bandwidth
  - 1.8% EVM up to 16 dBm for MCS9–40 MHz bandwidth
  - Meets 802.11b ACPR requirement up to 23 dBm
- **High power-added efficiency/Low operating current for 802.11b/g/n applications**
  - ~34%/200 mA @  $P_{OUT} = 23.5$  dBm for 802.11g
  - ~31%/195 mA @  $P_{OUT} = 23$  dBm for 802.11b
- **Single-pin low  $I_{REF}$  power-up/down control**
  - $I_{REF} < 2$  mA
- **Low idle current**
  - ~40-65 mA  $I_{CQ}$ , depending on package type and configuration.
- **High-speed power-up/down**
  - Turn on/off time (10%- 90%) <100 ns
  - Typical power-up/down delay with driver delay included <200 ns
- **Low Shut-down Current (~2  $\mu$ A)**
- **High temperature stability**
  - ~1 dB gain/power variation between 0°C to +85°C
- **Excellent On-chip power detection**
  - 20 dB dynamic range on-chip power detection
  - dB-wise linear output voltage
  - Temperature stable and load insensitive
- **Simple input/output matching**
- **Packages available**
  - 8-contact XSON – 2mm x 2mm x 0.5 mm max
  - 6-contact XSON – 1.5mm x 1.5mm x 0.5 mm max
  - 6-contact X2SON – 1.5mm x 1.5mm x 0.4mm max
- **All non-Pb (lead-free) devices are RoHS compliant**

## Applications

- **WLAN (IEEE 802.11b/g/n/256 QAM)**
- **Bluetooth**
- **ZigBee**
- **Cordless phones**
- **2.4 GHz ISM wireless equipment**

### Product Description

SST12LP19E is a versatile, 2.4 GHz power amplifier based on the highly-reliable InGaP/GaAs HBT technology. While it is designed to meet the high-linearity requirement of IEEE 802.11b/g/n/256 QAM, the power amplifier's high efficiency also makes it useful for Bluetooth and ZigBee applications.

SST12LP19E can be easily configured for high-power applications with good power-added efficiency while operating over the 2.4- 2.5 GHz frequency band. It typically provides 25 dB gain with 34% power-added efficiency (PAE) @  $P_{OUT} = 23.5$  dBm for 802.11g and 31% PAE @  $P_{OUT} = 23$  dBm for 802.11b.

This device has excellent linearity, typically ~3% added EVM at 19.5 dBm output power which is essential for 54 Mbps 802.11g operation while meeting 802.11g spectrum mask at 23.5 dBm and 802.11b spectrum mask at 23 dBm.

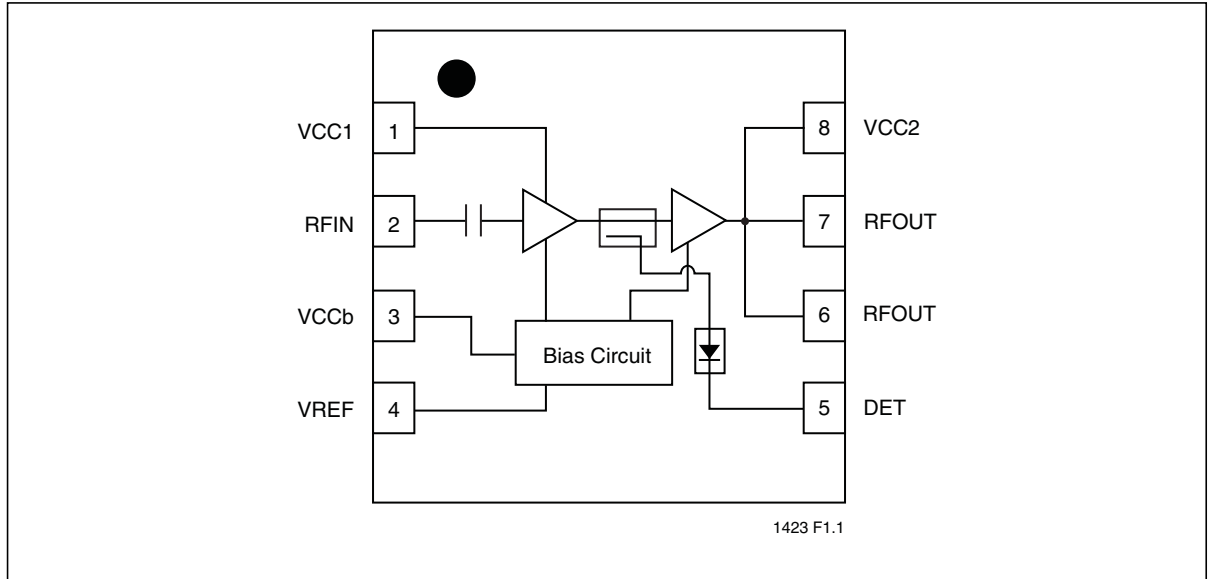
SST12LP19E can also be easily configured for high-efficiency operation, typically 3% added EVM at 18 dBm output power and 92 mA total power consumption for 54 Mbps 802.11g applications. It operates at 2.5% EM at typically 16.5 dBm for MCS7-20 MHz and 1.8% EVM at 16 dBm for MCS9-40 MHz bandwidth. High-efficiency operation is desirable in embedded applications, such as in hand-held units, where SST12LP19E can provide 25 dB gain and meet 802.11b/g/n/256 QAM spectrum mask at 22 dBm output power with 34% PAE.

This power amplifier also features easy board-level usage along with high-speed power-up/down control through a single combined reference voltage pin. Ultra-low reference current (total  $I_{REF} \sim 2$  mA) makes the SST12LP19E controllable by an on/off switching signal directly from the baseband chip. These features coupled with low operating current make the SST12LP19E ideal for the final stage power amplification in battery-powered 802.11b/g/n/256 QAM WLAN transmitter applications.

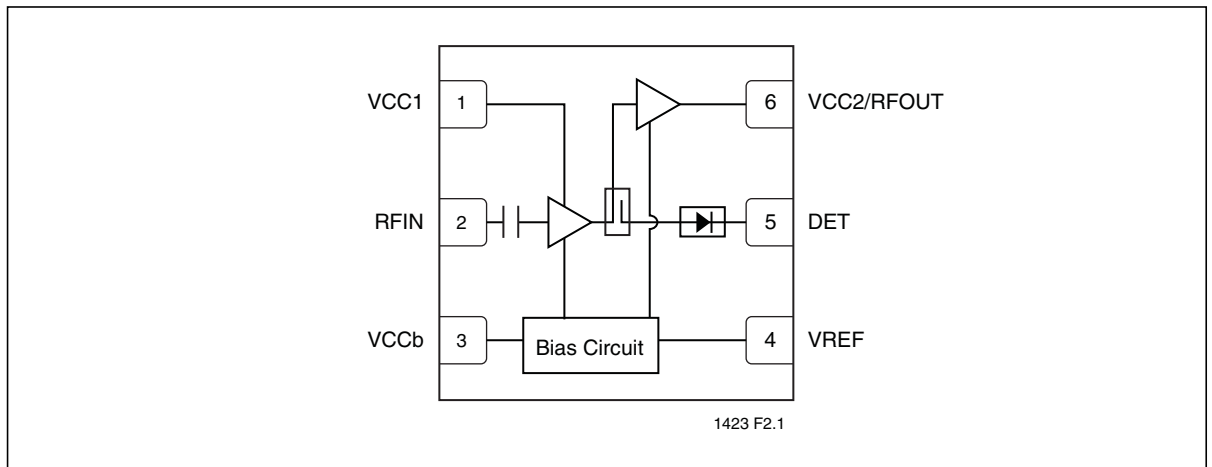
SST12LP19E has an excellent on-chip, single-ended power detector, which features wide-range (>20 dB) with dB-wise linear output voltage. The excellent on-chip power detector provides a reliable solution to board-level power control.

The SST12LP19E is offered in 8-contact XSON, 6-contact XSON, and 6-contact X2SON packages. See Figure 3 for pin assignments and Tables 1 and 2 for pin descriptions.

### Functional Blocks

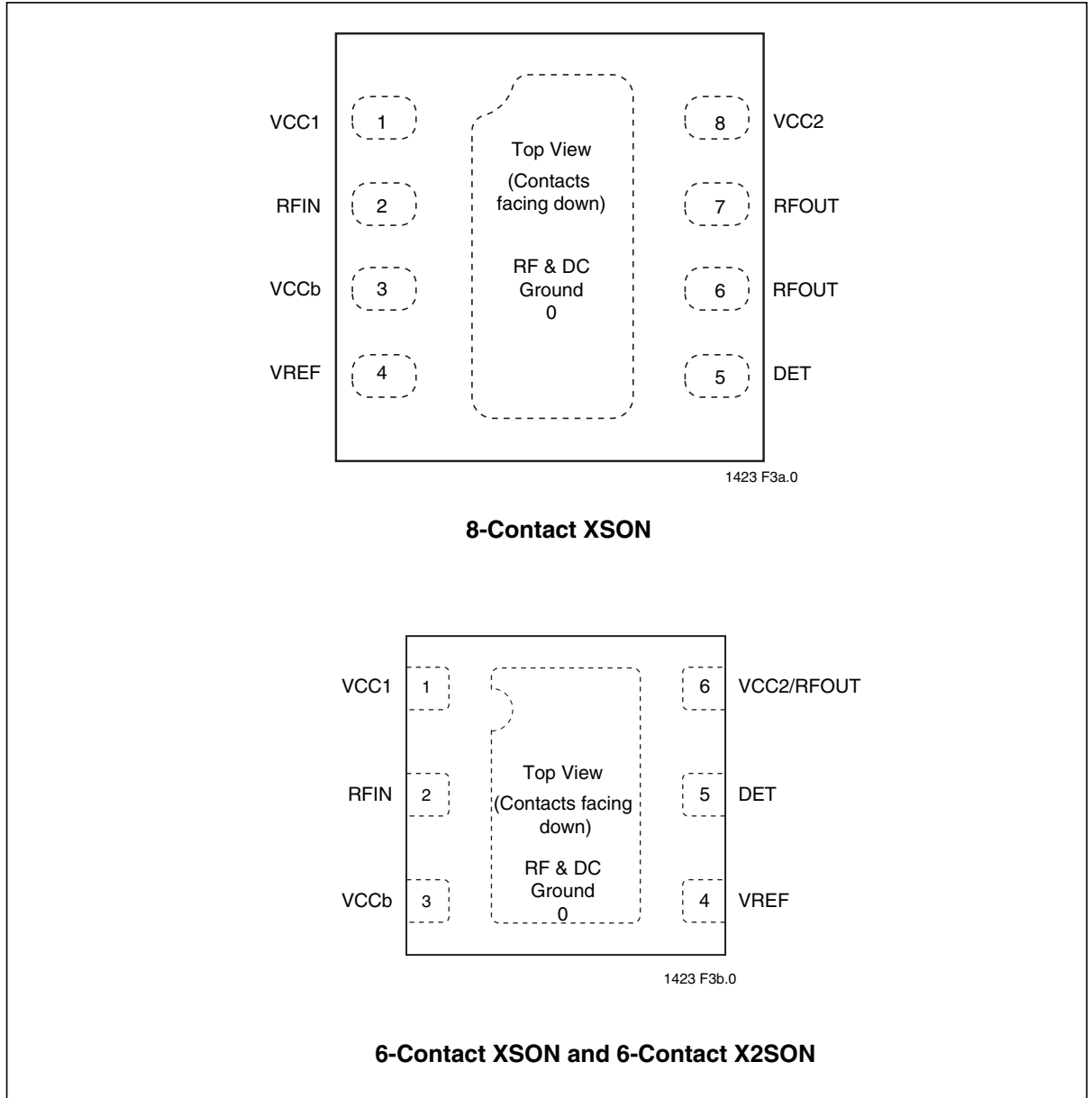


**Figure 1:** Functional Block Diagram 8-Contact XSON (QX8)



**Figure 2:** Functional Block Diagram 6-Contact XSON (QX6) and 6-contact X2SON (NR)

### Pin Assignments



**Figure 3:** Pin Assignments

## Pin Descriptions

**Table 1:** Pin Description, 8-contact XSON (QX8)

Symbol	Pin No.	Pin Name	Type <sup>1</sup>	Function
GND	0	Ground		Low inductance ground pad
V <sub>CC1</sub>	1	Power Supply	PWR	Power supply, 1 <sup>st</sup> stage
RF <sub>IN</sub>	2		I	RF input, DC decoupled
V <sub>CCb</sub>	3	Power Supply	PWR	Supply voltage for bias circuit
VREF	4		PWR	1 <sup>st</sup> and 2 <sup>nd</sup> stage idle current control
Det	5		O	On-chip power detector
RF <sub>OUT</sub>	6		O	RF output
RF <sub>OUT</sub>	7		O	RF output
V <sub>CC2</sub>	8	Power Supply	PWR	Power supply, 2 <sup>nd</sup> stage

T1.0 75041

1. I=Input, O=Output

**Table 2:** Pin Description, 6-contact XSON (QX6) and 6-contact X2SON(NR)

Symbol	Pin No.	Pin Name	Type <sup>1</sup>	Function
GND	0	Ground		Low inductance ground pad
V <sub>CC1</sub>	1	Power Supply	PWR	Power supply, 1 <sup>st</sup> stage
RF <sub>IN</sub>	2		I	RF input, DC decoupled
V <sub>CCb</sub>	3	Power Supply	PWR	Supply voltage for bias circuit
VREF	4		PWR	1 <sup>st</sup> and 2 <sup>nd</sup> stage idle current control
Det	5		O	On-chip power detector
V <sub>CC2</sub> / RF <sub>OUT</sub>	6	Power Supply	PWR/O	Power supply, 2 <sup>nd</sup> stage/ RF Output

T2.0 75041

1. I=Input, O=Output

### Electrical Specifications

The RF and DC specifications for the power amplifier interface signals. Refer to Table 4 for the DC voltage and current specifications. Refer to Figures 4 through 15 for the RF performance.

**Absolute Maximum Stress Ratings** (Applied conditions greater than those listed under “Absolute Maximum Stress Ratings” may cause permanent damage to the device. This is a stress rating only and functional operation of the device at these conditions or conditions greater than those defined in the operational sections of this data sheet is not implied. Exposure to absolute maximum stress rating conditions may affect device reliability.)

Input power to pin 2 ( $P_{IN}$ )	+5 dBm
Average output power from pins 6 and 7 ( $P_{OUT}$ ) <sup>1</sup> for 8-contact XSON	+26 dBm
Average output power from pin 6 ( $P_{OUT}$ ) <sup>1</sup> for 6-contact XSON/X2SON	+26 dBm
Supply Voltage to pins 1, 3, and 8 ( $V_{CC}$ ) for 8-contact XSON	-0.3V to +4.6V
Supply Voltage to pins 1, 3, and 6 ( $V_{CC}$ ) for 6-contact XSON/X2SON	-0.3V to +4.6V
Reference voltage to pin 4 ( $V_{REF}$ )	-0.3V to +3.3V
DC supply current ( $I_{CC}$ ) <sup>2</sup>	400 mA
Operating Temperature ( $T_A$ )	-40°C to +85°C
Storage Temperature ( $T_{STG}$ )	-40°C to +120°C
Maximum Junction Temperature ( $T_J$ )	+150°C
Surface Mount Solder Reflow Temperature	260°C for 10 seconds

1. Never measure with CW source. Pulsed single-tone source with <50% duty cycle is recommended. Exceeding the maximum rating of average output power could cause permanent damage to the device.
2. Measured with 100% duty cycle 54 Mbps 802.11g OFDM Signal

**Table 3: Operating Range**

Range	Ambient Temp	$V_{DD}$
Industrial	-40°C to +85°C	3.3V

T3.1 75041

**Table 4:** DC Electrical Characteristics at 25°C

Symbol	Parameter	Min.	Typ	Max.	Unit	Test Conditions
V <sub>CC</sub>	Supply Voltage at pins 1, 3, and 8 for 8-contact XSON	3.0	3.3	4.2	V	Figures 16 and 17
	Supply Voltage at pins 1, 3, 6 for 6-contact XSON/X2SON	3.0	3.3	4.2	V	Figures 18 and 19
I <sub>CC</sub>	Idle current to meet EVM ~3% @ 19.5 dBm for 8-contact XSON <sup>1</sup>		60		mA	Figure 16
	Idle current to meet EVM ~2.5% @ 18 dBm for 8-contact XSON <sup>1</sup>		45			Figure 17
	Idle current to meet EVM ~3% @ 19.5 dBm for 6-contact XSON/X2SON <sup>1</sup>		50		mA	Figure 18
	Idle current to meet EVM ~2.5% @ 18 dBm for 6-contact XSON/X2SON <sup>1</sup>		45		mA	Figure 19
I <sub>CC</sub> (802.11g)	Current consumption to meet EVM ~3% @ 19.5 dBm for 8-contact XSON <sup>1</sup>		130		mA	Figure 16
	Current consumption to meet EVM ~2.5% @ 18 dBm for 8-contact XSON <sup>1</sup>		92		mA	Figure 17
	Current consumption to meet EVM ~3% @ 19.5 dBm for 6-contact XSON/X2SON <sup>1</sup>		132		mA	Figure 18
	Current consumption to meet EVM ~2.5% @ 18 dBm for 6-contact XSON/X2SON <sup>1</sup>		90		mA	Figure 19
I <sub>CC</sub> (802.11g Mask)	Current consumption to meet Spectrum Mask @23.5 dBm for 8-contact XSON <sup>1</sup>		200		mA	Figure 16
	Current consumption to meet Spectrum Mask @22 dBm for 8-contact XSON <sup>1</sup>		140		mA	Figure 17
	Current consumption to meet Spectrum Mask @23.5 dBm for 6-contact XSON/X2SON <sup>1</sup>		190		mA	Figure 18
	Current consumption to meet Spectrum Mask @22 dBm for 6-contact XSON/X2SON <sup>1</sup>		138		mA	Figure 19
I <sub>CC</sub> (802.11b Mask)	Current consumption to meet Spectrum Mask @23 dBm for 8-contact XSON <sup>2</sup>		195		mA	Figure 16
	Current consumption to meet Spectrum Mask @22 dBm for 8-contact XSON <sup>2</sup>		140		mA	Figure 17
	Current consumption to meet Spectrum Mask @23 dBm for 6-contact XSON/X2SON <sup>2</sup>		185		mA	Figure 18
	Current consumption to meet Spectrum Mask @22.5 dBm for 6-contact XSON/X2SON <sup>2</sup>		150		mA	Figure 19
V <sub>REG</sub>	Reference Voltage for 8-contact XSON with no resistor	2.75	2.85	2.95	V	Figure 16
	Reference Voltage for 8-contact XSON with 300Ω resistor	2.75	2.85	2.95	V	Figure 17
	Reference Voltage for 6-contact XSON/X2SON with 200Ω resistor	2.75	2.85	2.95	V	Figure 18
	Reference Voltage for 6-contact XSON/X2SON with 360Ω resistor	2.75	2.85	2.95	V	Figure 19

1. 802.11g OFDM 54 Mbps signal
2. 802.11b DSSS 1 Mbps signal

T4.2 75041

**Table 5:** RF Characteristics at 25°C<sup>1</sup>

Symbol	Parameter	Min.	Typ	Max.	Unit	Test Conditions
FL-U	Frequency range	2412		2484	MHz	
G	Small signal gain	24	25		dB	
G <sub>VAR1</sub>	Gain variation over band (2412–2484 MHz)			±0.5	dB	
G <sub>VAR2</sub>	Gain ripple over channel (20 MHz)		0.2		dB	
2f, 3f, 4f, 5f	Harmonics at 22 dBm, without external filters			-30	dBc	
EVM	EVM @ 19.5 dBm output power for 8-contact XSON <sup>2</sup> using 802.11g, 54 Mbps modulation		3		%	Figure 16
	EVM @ 18 dBm output power for 8-contact XSON <sup>2</sup> using 802.11g, 54 Mbps modulation		2.5	3	%	Figure 17
	EVM @ 19.5 dBm output power for 6-contact XSON/X2SON <sup>2</sup> using 802.11g, 54 Mbps modulation		3		%	Figure 18
	EVM @ 18 dBm output power for 6-contact XSON/X2SON <sup>2</sup> using 802.11g, 54 Mbps modulation		2.5	3	%	Figure 19
	Dynamic EVM @ 16.5 dBm for 8-contact XSON with MCS7-20 modulation		2.5		%	Figure 16
	Dynamic EVM @ 16 dBm for 8-contact XSON with MCS9-40 modulation		1.8		%	Figure 16
P <sub>OUT</sub> (802.11g MASK)	Output power to meet Spectrum Mask for 8-contact XSON <sup>2</sup>	22.5	23.5		dBm	Figure 16
	Output power to meet Spectrum Mask for 8-contact XSON <sup>2</sup>	21	22		dBm	Figure 17
	Output power to meet Spectrum Mask for 6-contact XSON/X2SON <sup>2</sup>	22.5	23.5		dBm	Figure 18
	Output power to meet Spectrum Mask for 6-contact XSON/X2SON <sup>2</sup>	21	22		dBm	Figure 19
P <sub>OUT</sub> (802.11b MASK)	Output power to meet Spectrum Mask for 8-contact XSON <sup>3</sup>	22	23		dBm	Figure 16
	Output power to meet Spectrum Mask for 8-contact XSON <sup>3</sup>	21	22		dBm	Figure 17
	Output power to meet Spectrum Mask for 6-contact XSON/X2SON <sup>3</sup>	22	23		dBm	Figure 18
	Output power to meet Spectrum Mask for 6-contact XSON/X2SON <sup>3</sup>	21.5	22.5		dBm	Figure 19
P <sub>OUT</sub> (Blue-tooth MASK)	Output power to meet spectrum mask for 6- and 8-contact XSON		17		dBm	

T5.2 75041

1. EVM measured with “sequence-only” equalizer channel estimation
2. 802.11g OFDM 54 Mbps signal
3. 802.11b DSSS 1 Mbps signal

### Typical Performance Characteristics

Test Conditions:  $V_{CC} = 3.3V$ ,  $V_{REG} = 2.85V$ ,  $T_A = 25^\circ C$ , unless otherwise specified

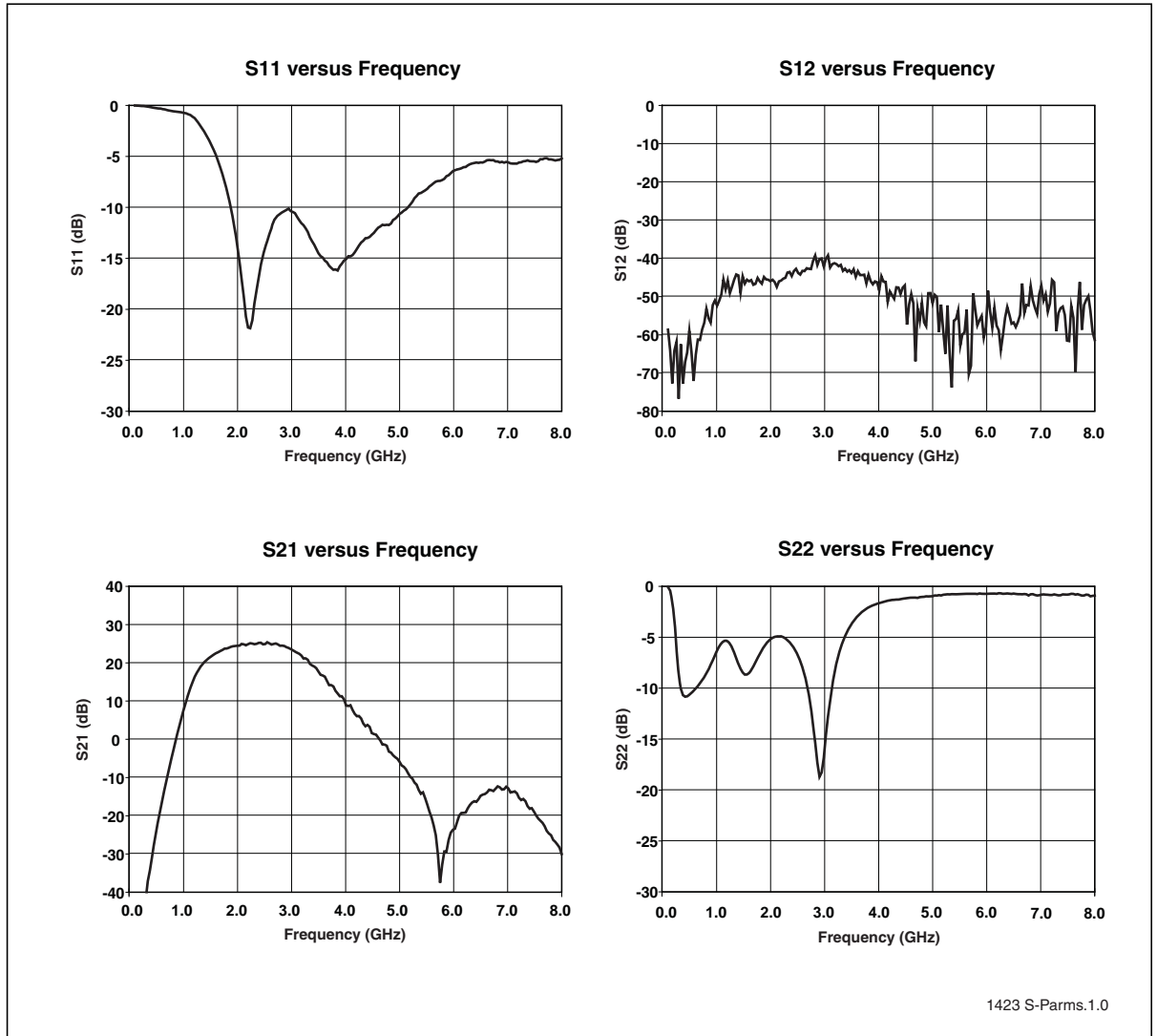


Figure 4: S-Parameters

### Typical Performance Characteristics for High-power applications

Test Conditions:  $V_{CC} = 3.3V$ ,  $V_{REG} = 2.85V$ ,  $T_A = 25^\circ C$ , 54 Mbps 802.11g OFDM Signal, QX6E example

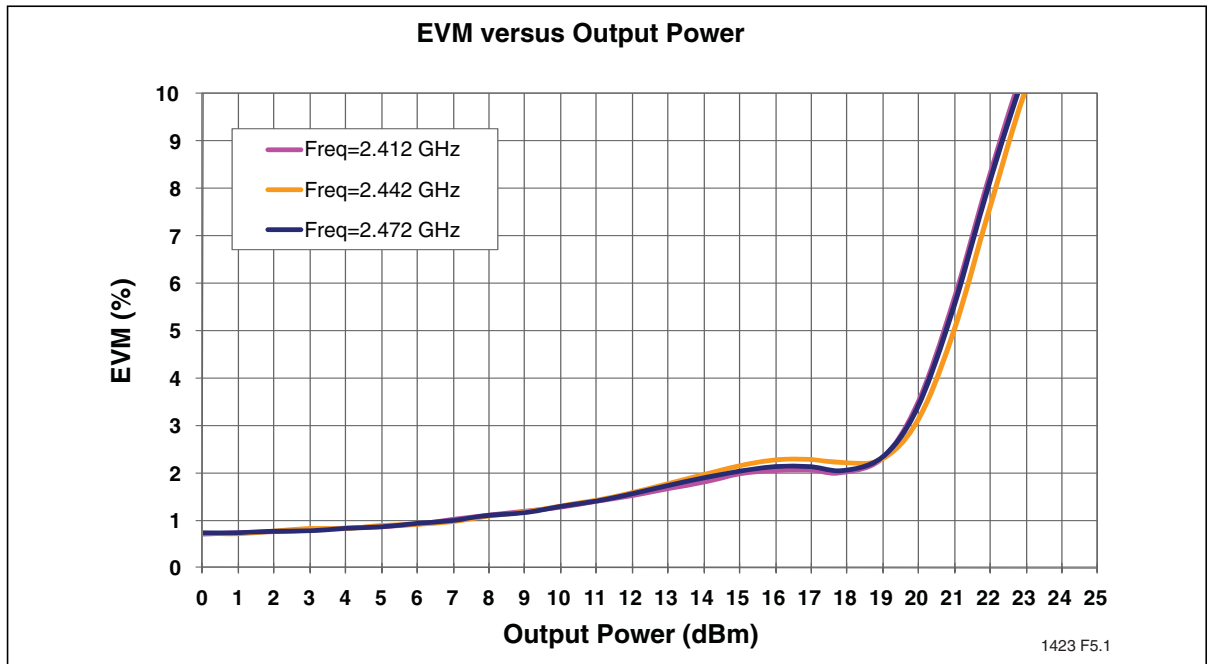


Figure 5: EVM versus Output Power, measured with Equalizer Channel Estimation set to “sequence only”

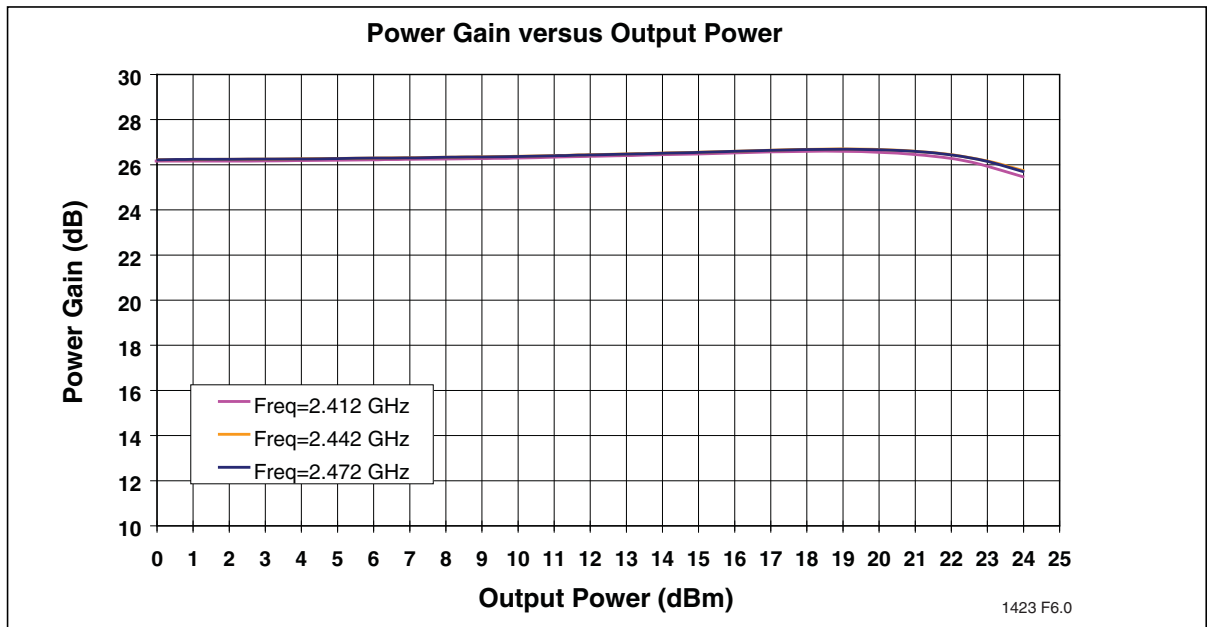
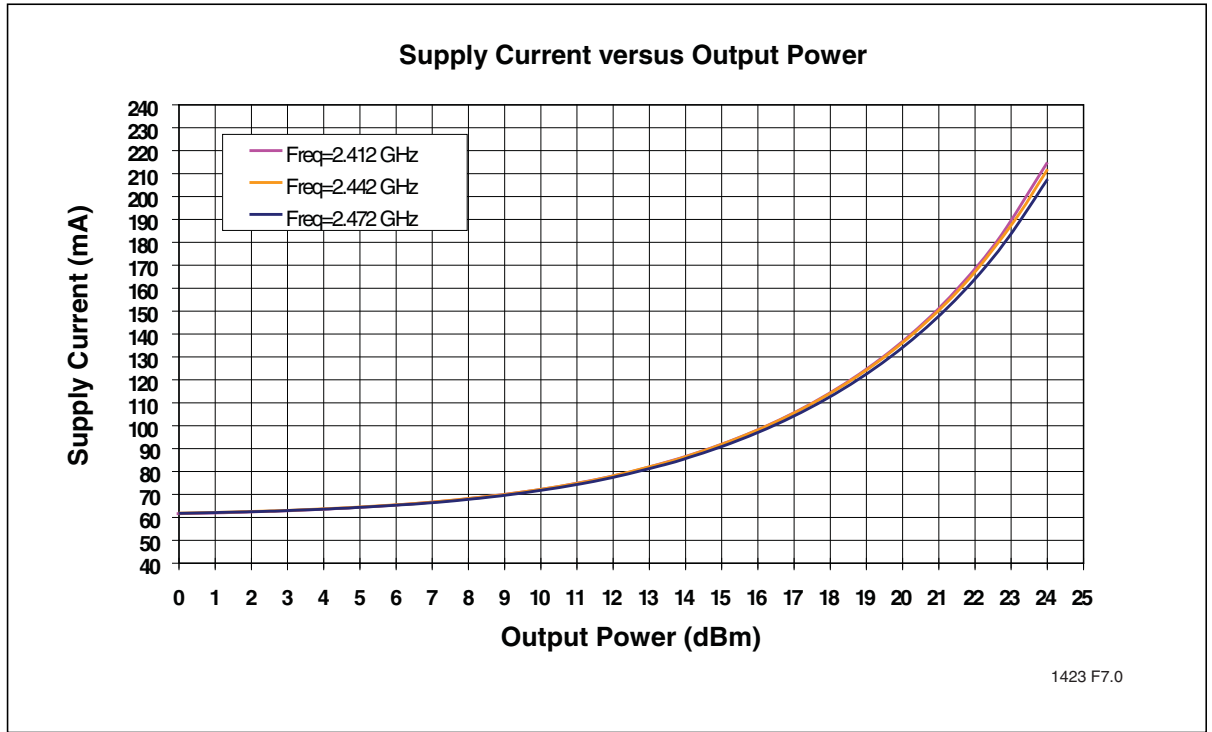
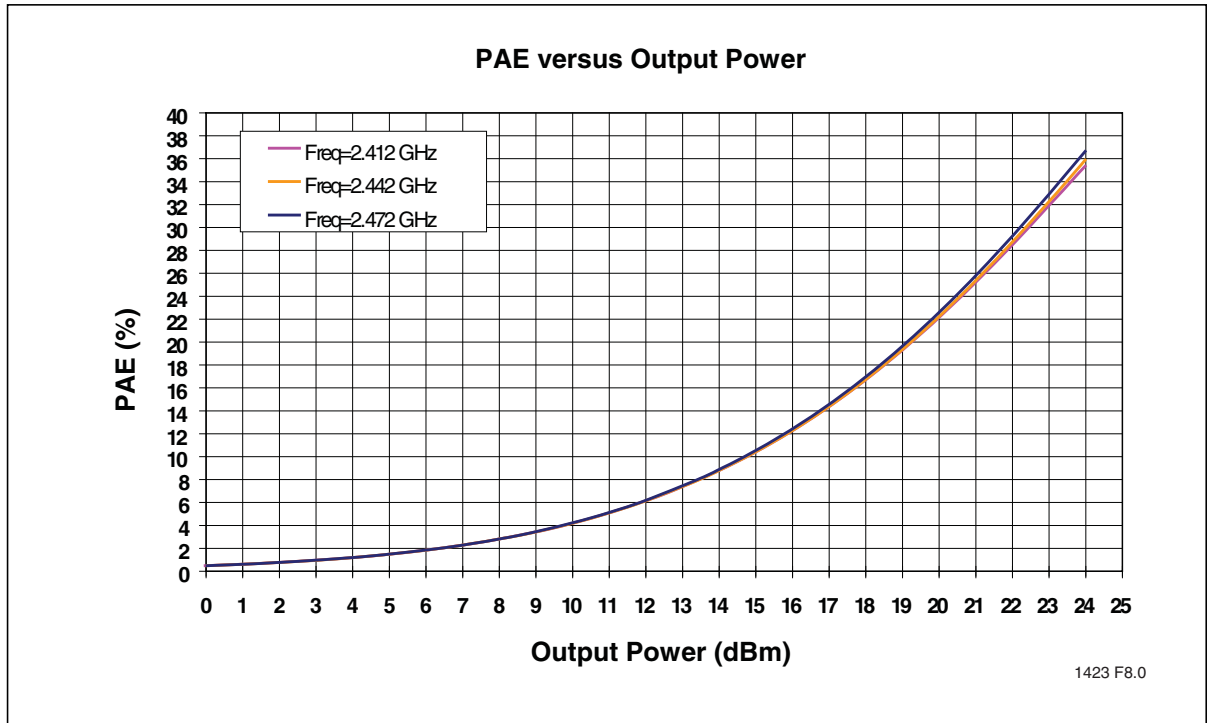


Figure 6: Power Gain versus Output Power



**Figure 7:** Total Current Consumption for 802.11g Operation versus Output Power



**Figure 8:** PAE versus Output Power

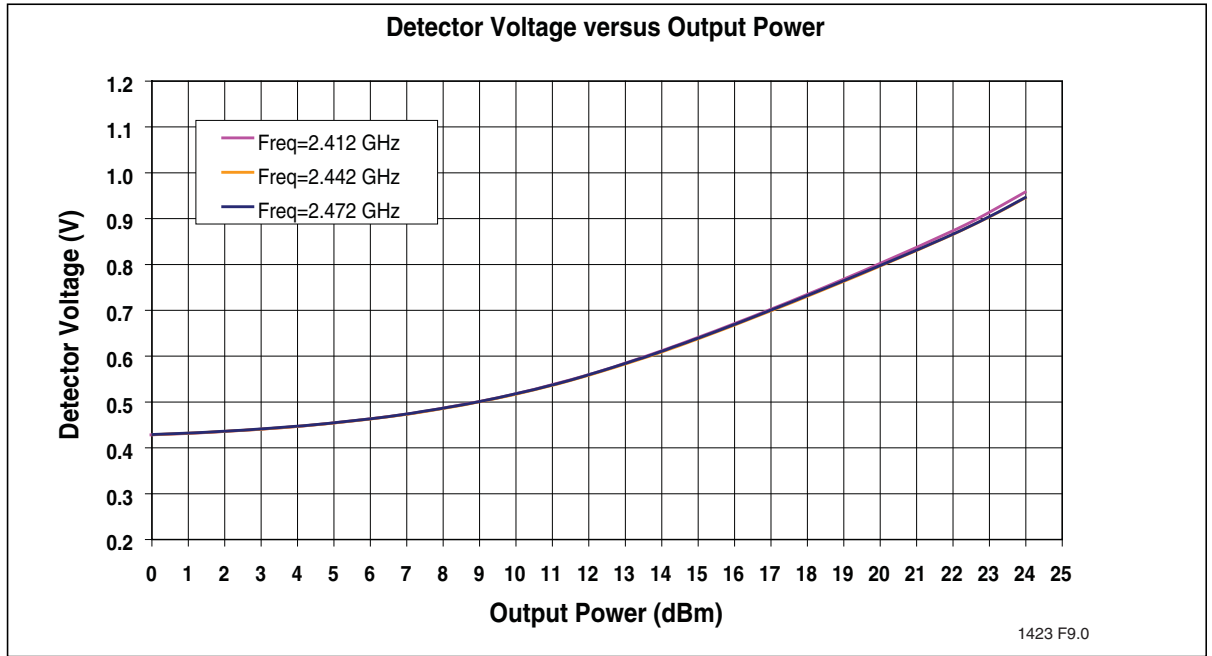


Figure 9: Detector Characteristics versus Output Power

### Typical Performance Characteristics for High-Efficiency Applications

Test Conditions:  $V_{CC} = 3.3V$ ,  $V_{REG} = 2.85V$ ,  $T_A = 25^\circ C$ , 54 Mbps 802.11g OFDM Signal, QX6E example

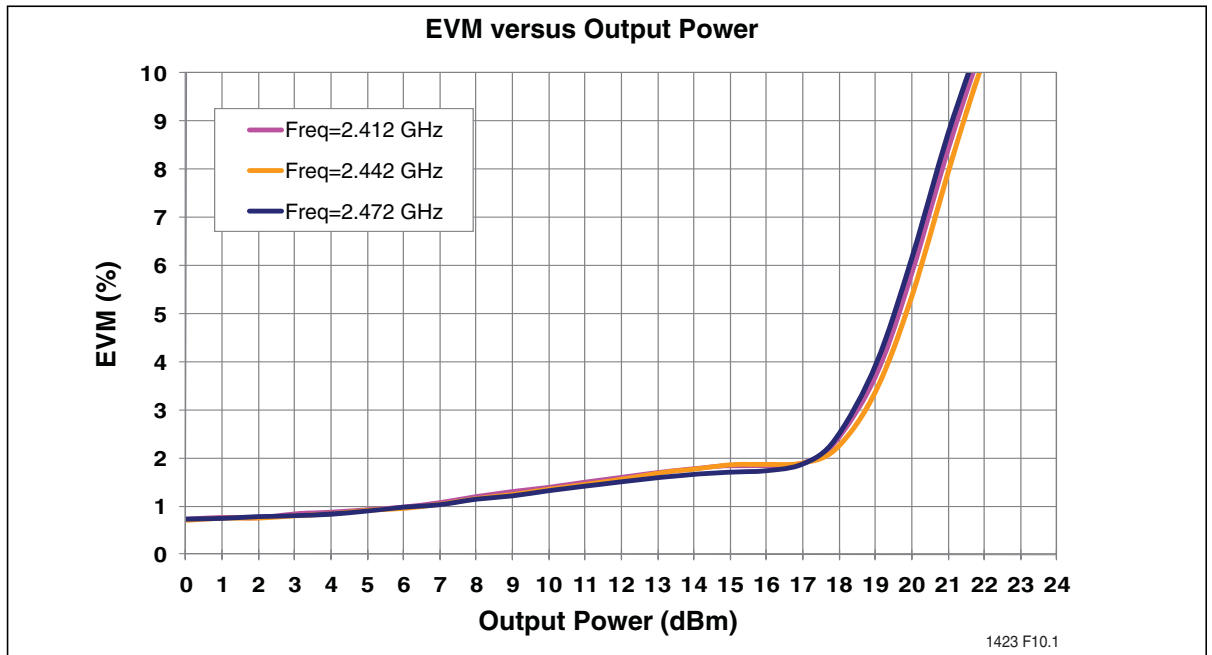


Figure 10: EVM versus Output Power, measured with Equalizer Channel Estimation set to “sequence only”

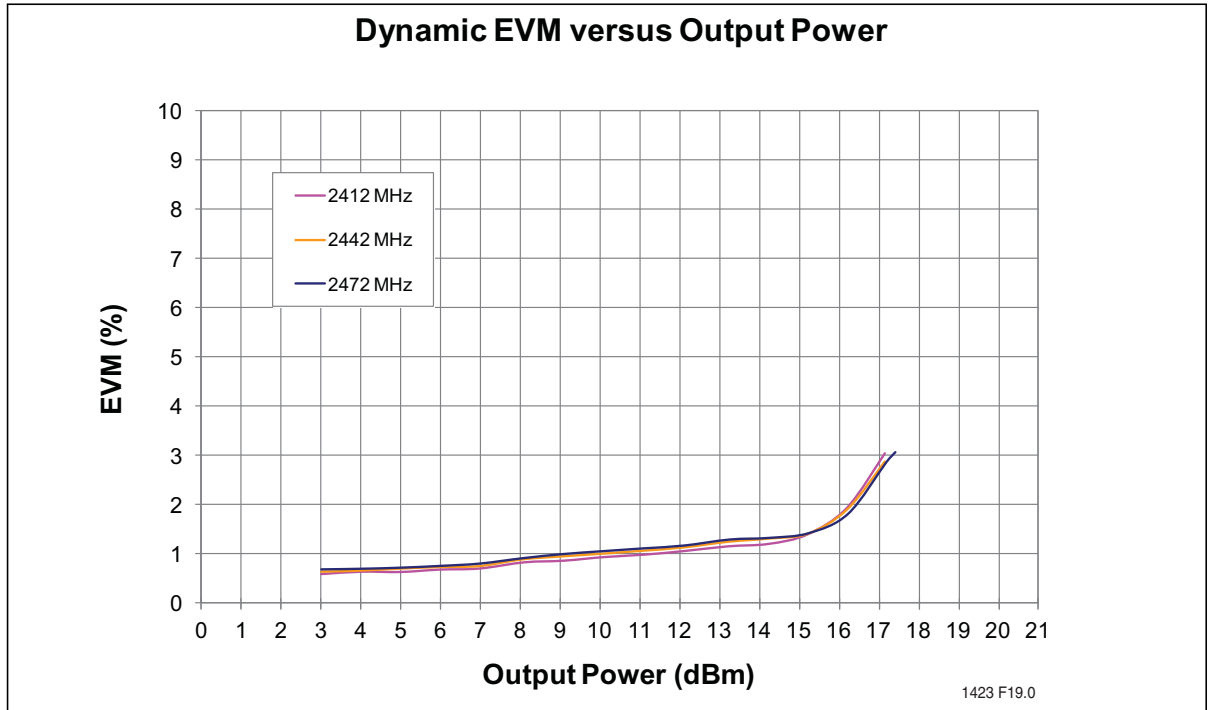


Figure 11: Dynamic EVM versus Output Power

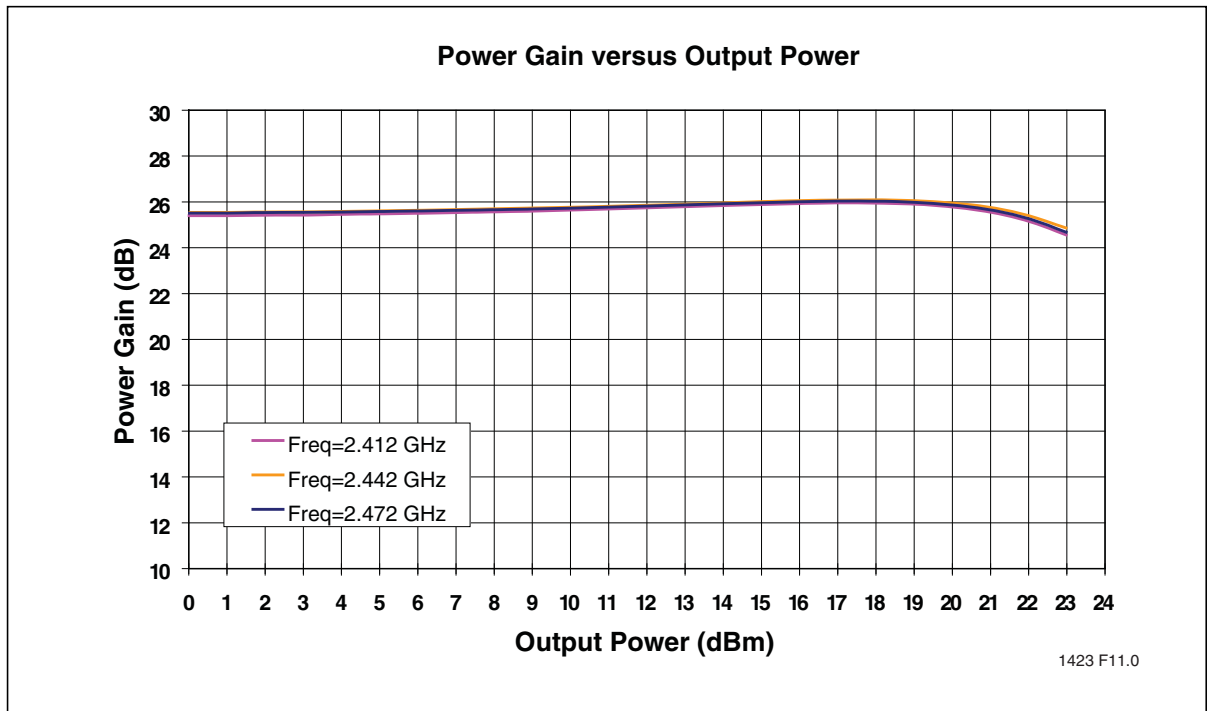
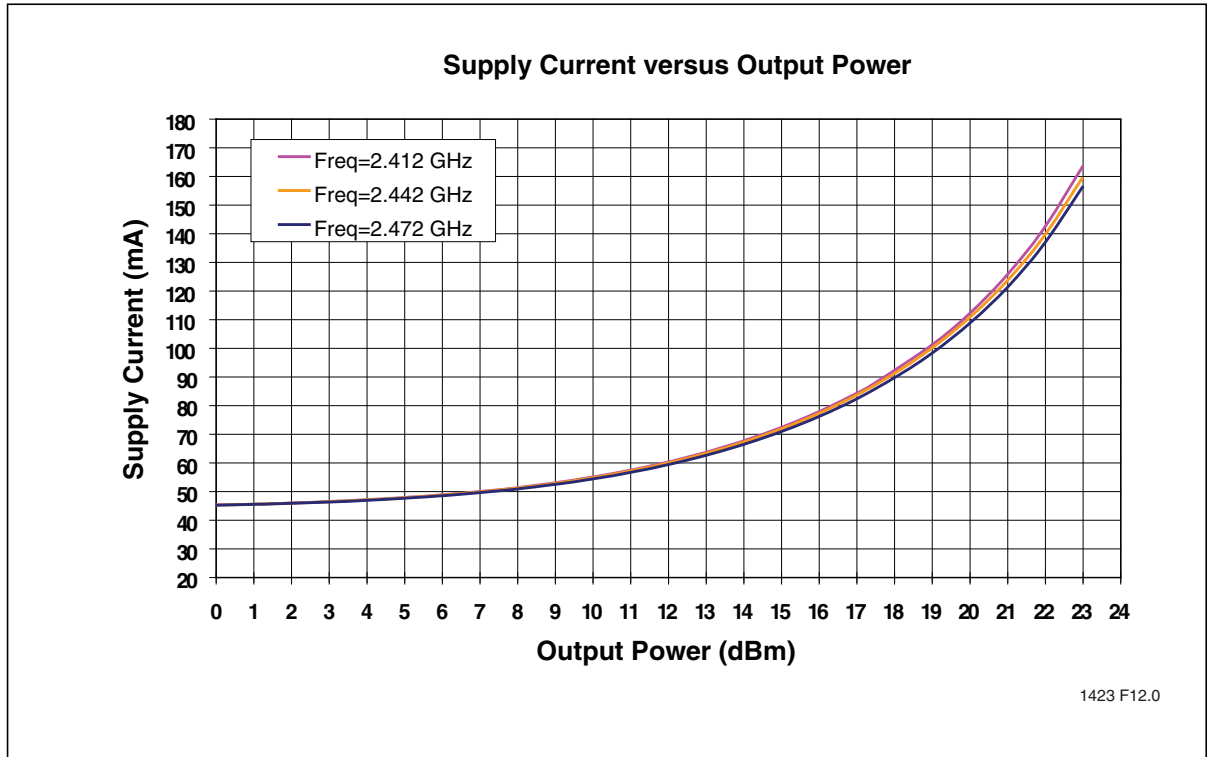
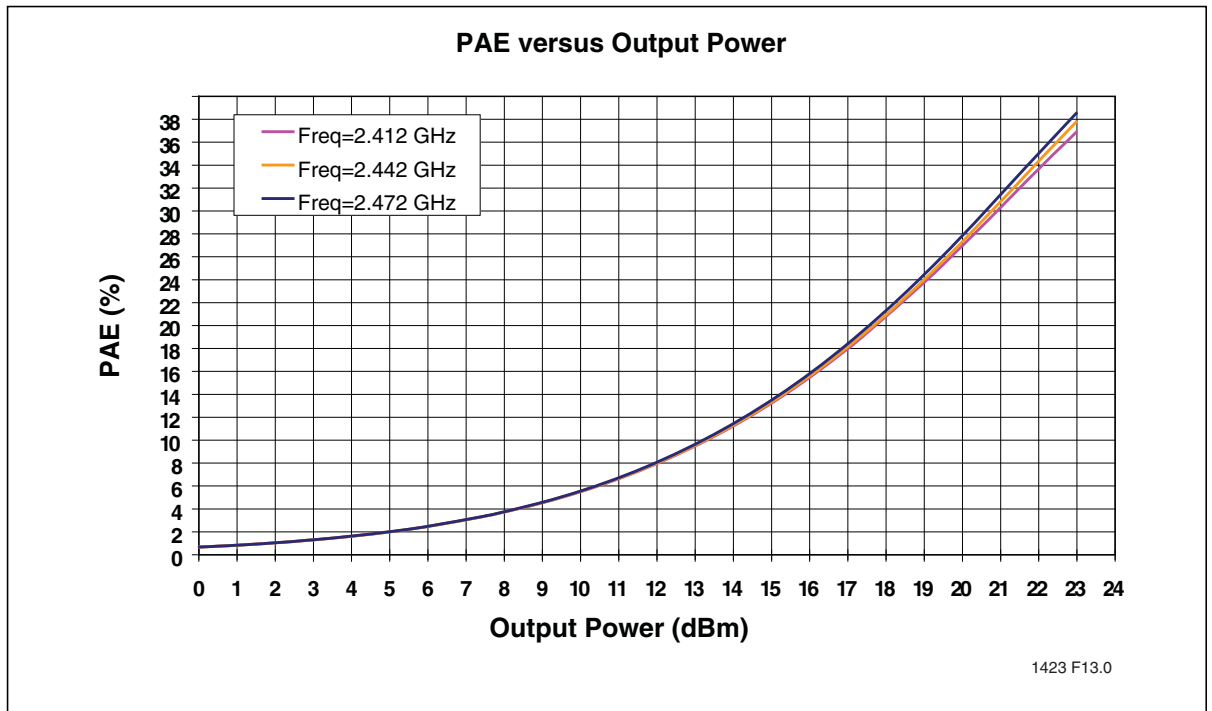


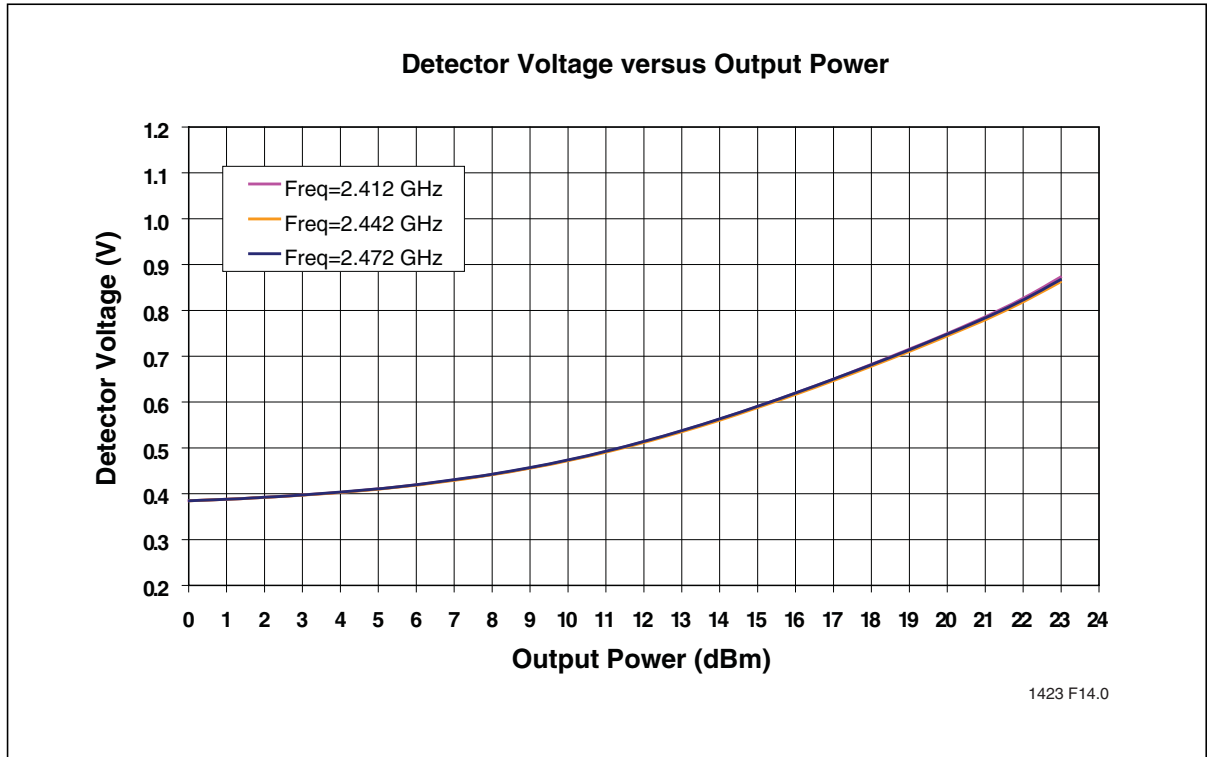
Figure 12: Power Gain versus Output Power



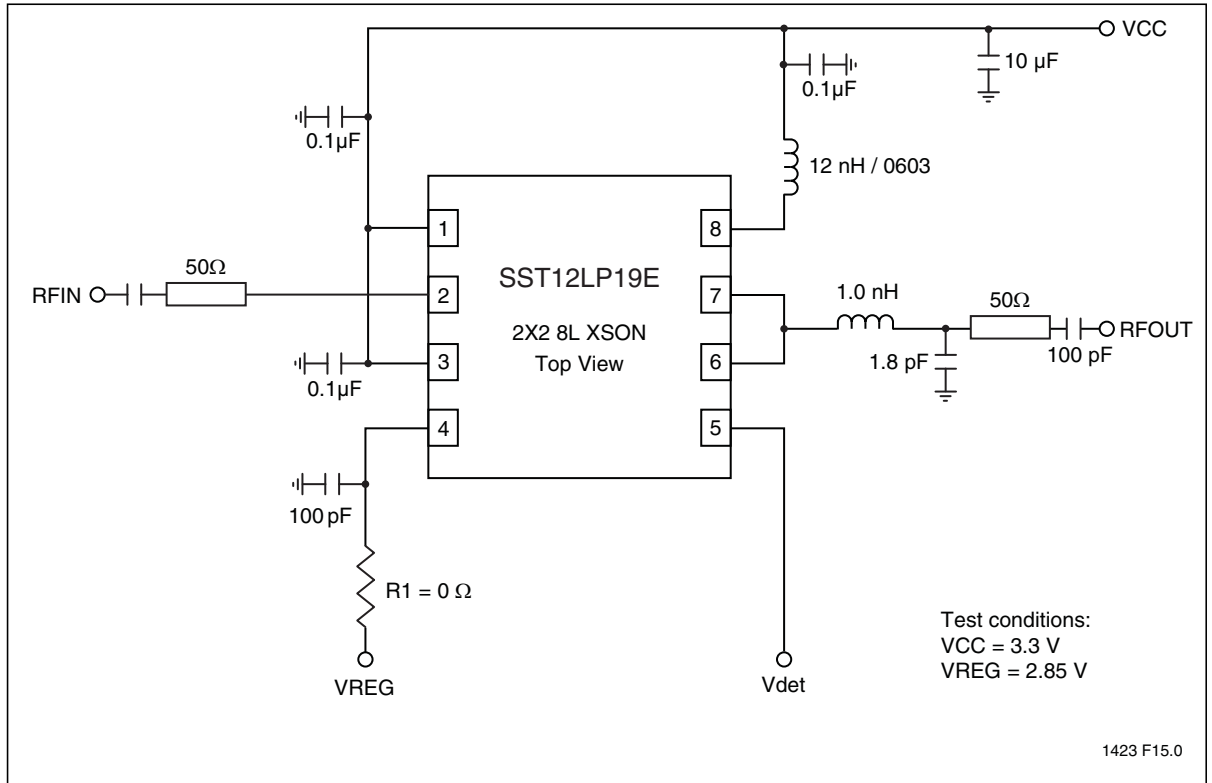
**Figure 13:**Total Current Consumption for 802.11g Operation versus Output Power



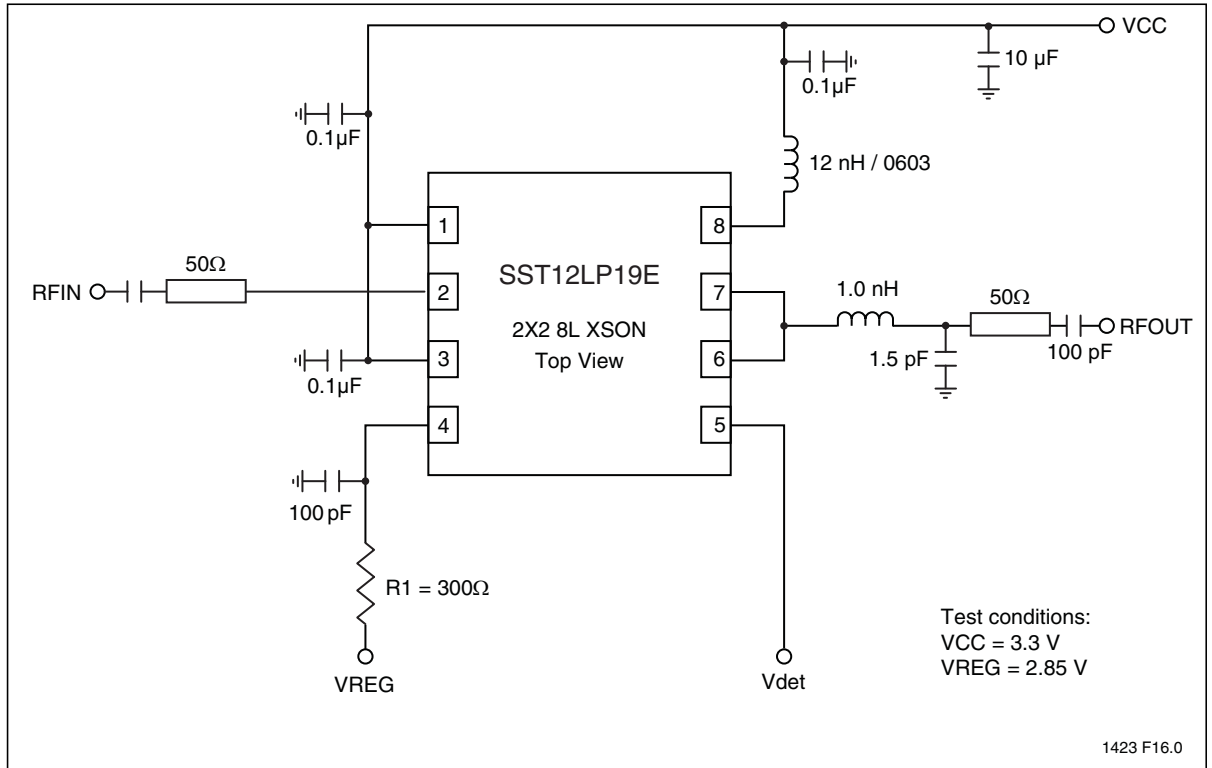
**Figure 14:**PAE versus Output Power



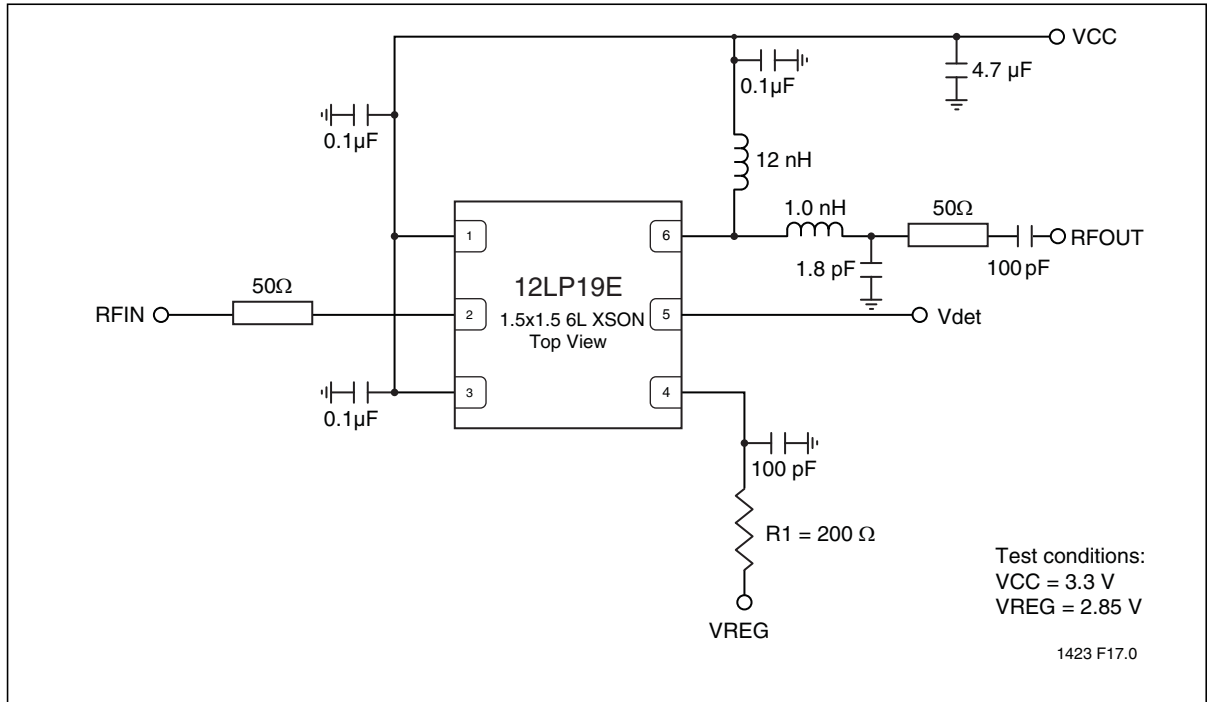
**Figure 15:**Detector Characteristics versus Output Power



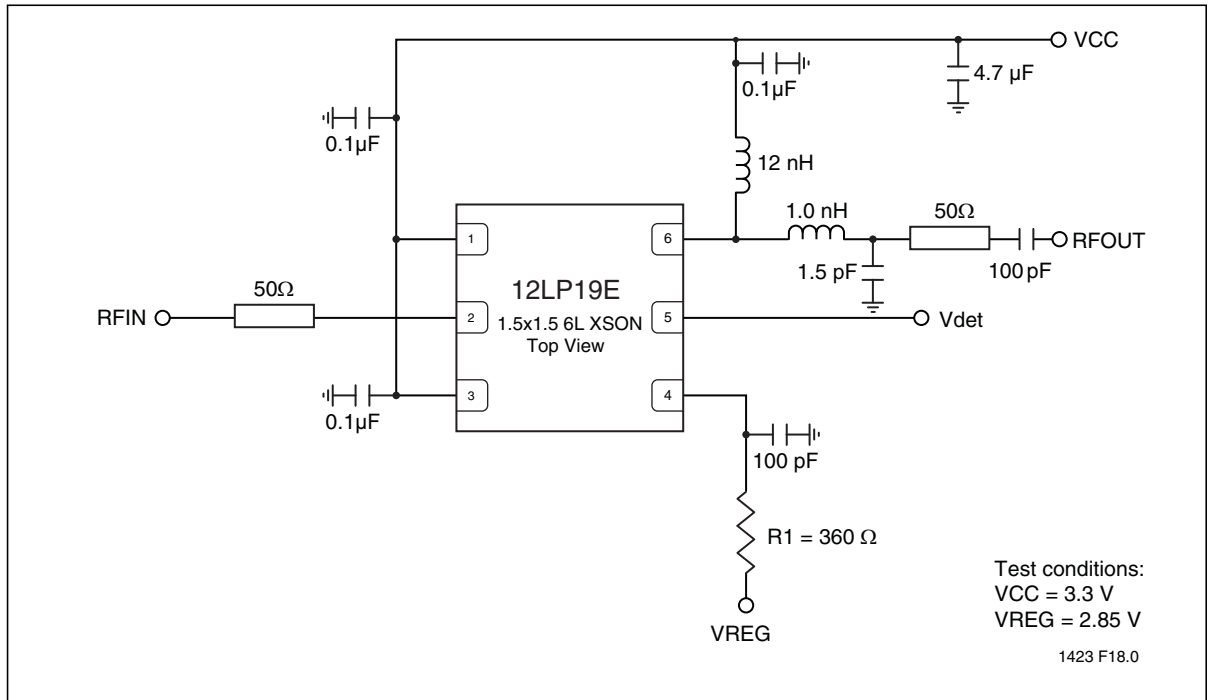
**Figure 16:** Typical Schematic for 8-Contact XSON (QX8) for High-Power Applications



**Figure 17:** Typical Schematic for 8-Contact XSON (QX8) for High-Efficiency Applications

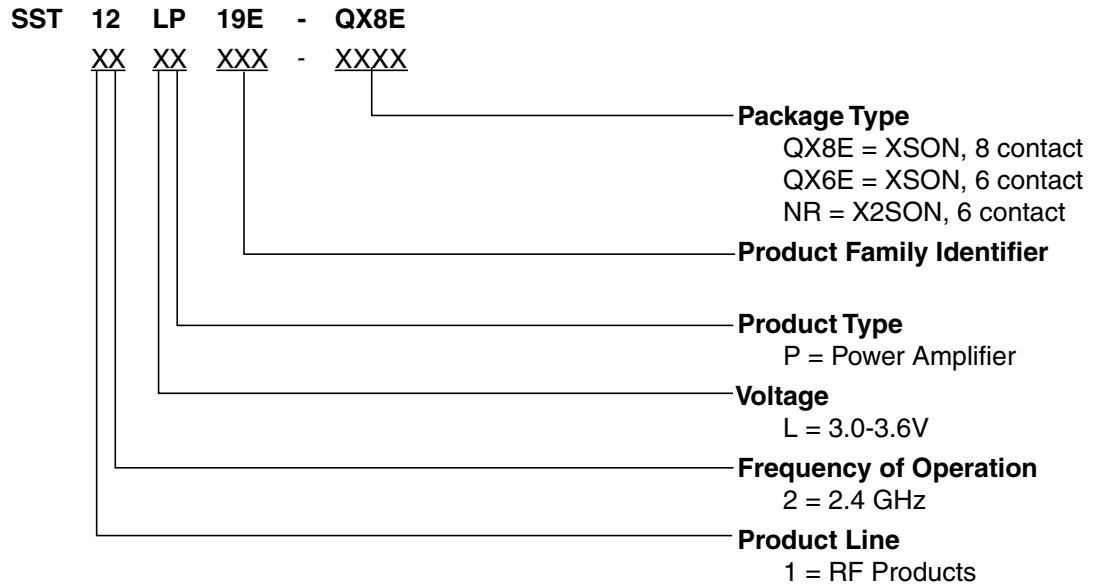


**Figure 18:** Typical Schematic for 6-Contact XSON (QX6) and 6-contact X2SON(NR) for High-Power Applications



**Figure 19:** Typical Schematic for 6-Contact XSON (QX6) and 6-contact X2SON(NR) for High-Efficiency Applications

### Product Ordering Information



#### Valid combinations for SST12LP19E

SST12LP19E-QX8E

SST12LP19E-QX6E

SST12LP19E-NR

#### SST12LP19E Evaluation Kits

SST12LP19E-QX8E-K

SST12LP19E-QX6E-K

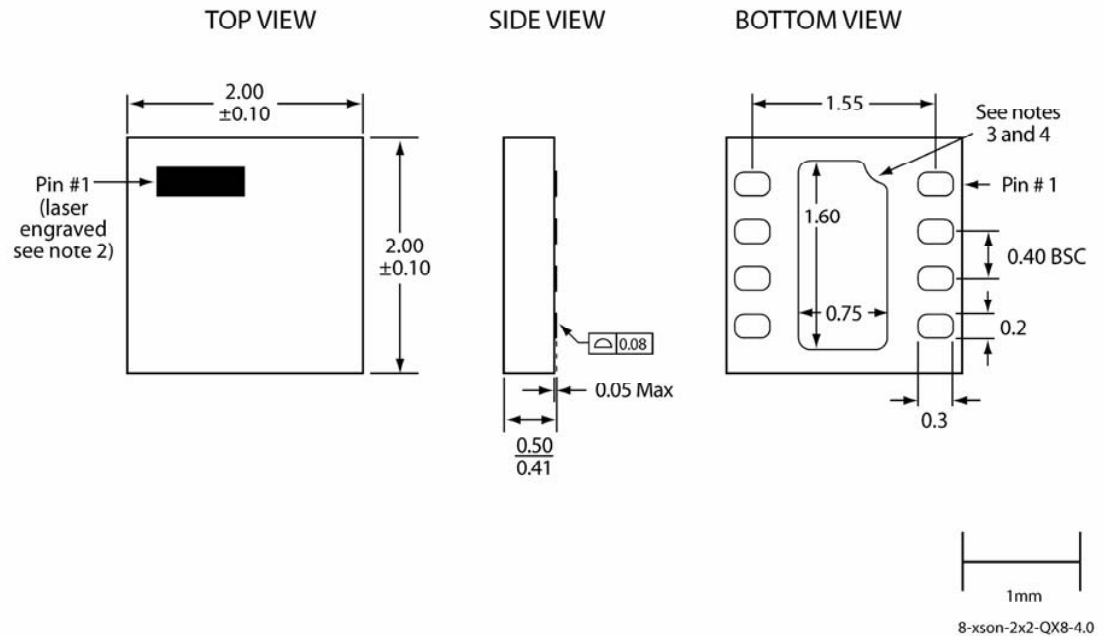
SST12LP19E-NR-K

**Note:** Valid combinations are those products in mass production or will be in mass production. Consult your SST sales representative to confirm availability of valid combinations and to determine availability of new combinations.

### Packaging Diagrams

#### 8-Lead Extremely Thin Small Outline No-Leads (QX8E/F) - 2x2 mm Body [XSON]

**Note:** For the most current package drawings, please see the Microchip Packaging Specification located at <http://www.microchip.com/packaging>

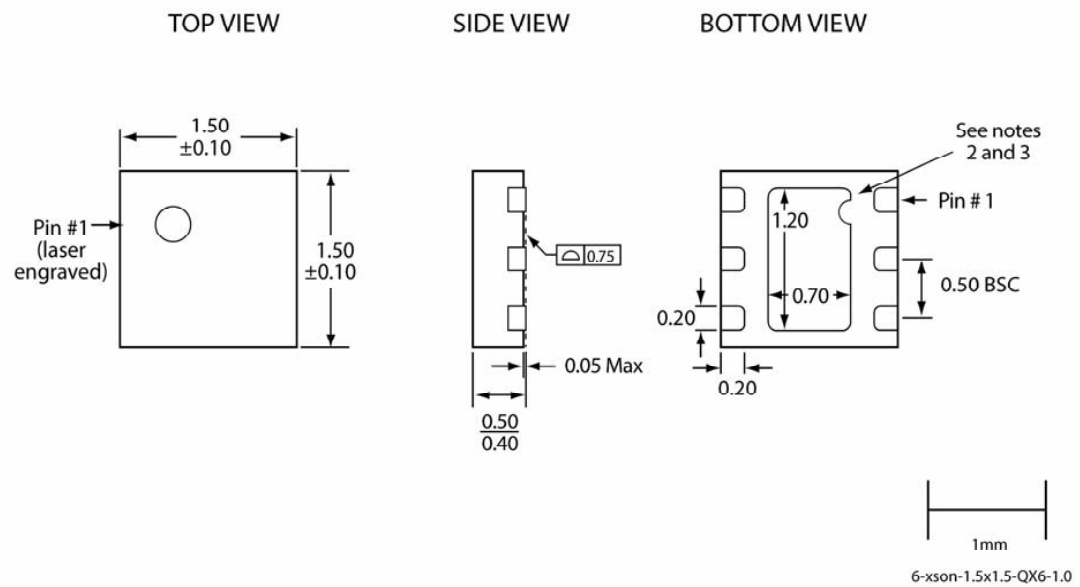


**Note:**

1. Similar to JEDEC JEP95 XQFN/XSON variants, though number of contacts and some dimensions are different.
2. The topside pin #1 indicator is laser engraved; its approximate shape and location is as shown.
3. From the bottom view, the pin #1 indicator may be either a curved indent or a 45-degree chamfer.
4. The external paddle is electrically connected to the die back-side and to VSS.  
This paddle must be soldered to the PC board; it is required to connect this paddle to the VSS of the unit.  
Connection of this paddle to any other voltage potential will result in shorts and electrical malfunction of the device.
5. Untoleranced dimensions are nominal target dimensions.
6. All linear dimensions are in millimeters (max/min).

### 6-Lead Extremely Thin Small Outline No-Leads (QX6E/F) - 1.5x1.5 mm Body [XSON]

**Note:** For the most current package drawings, please see the Microchip Packaging Specification located at <http://www.microchip.com/packaging>

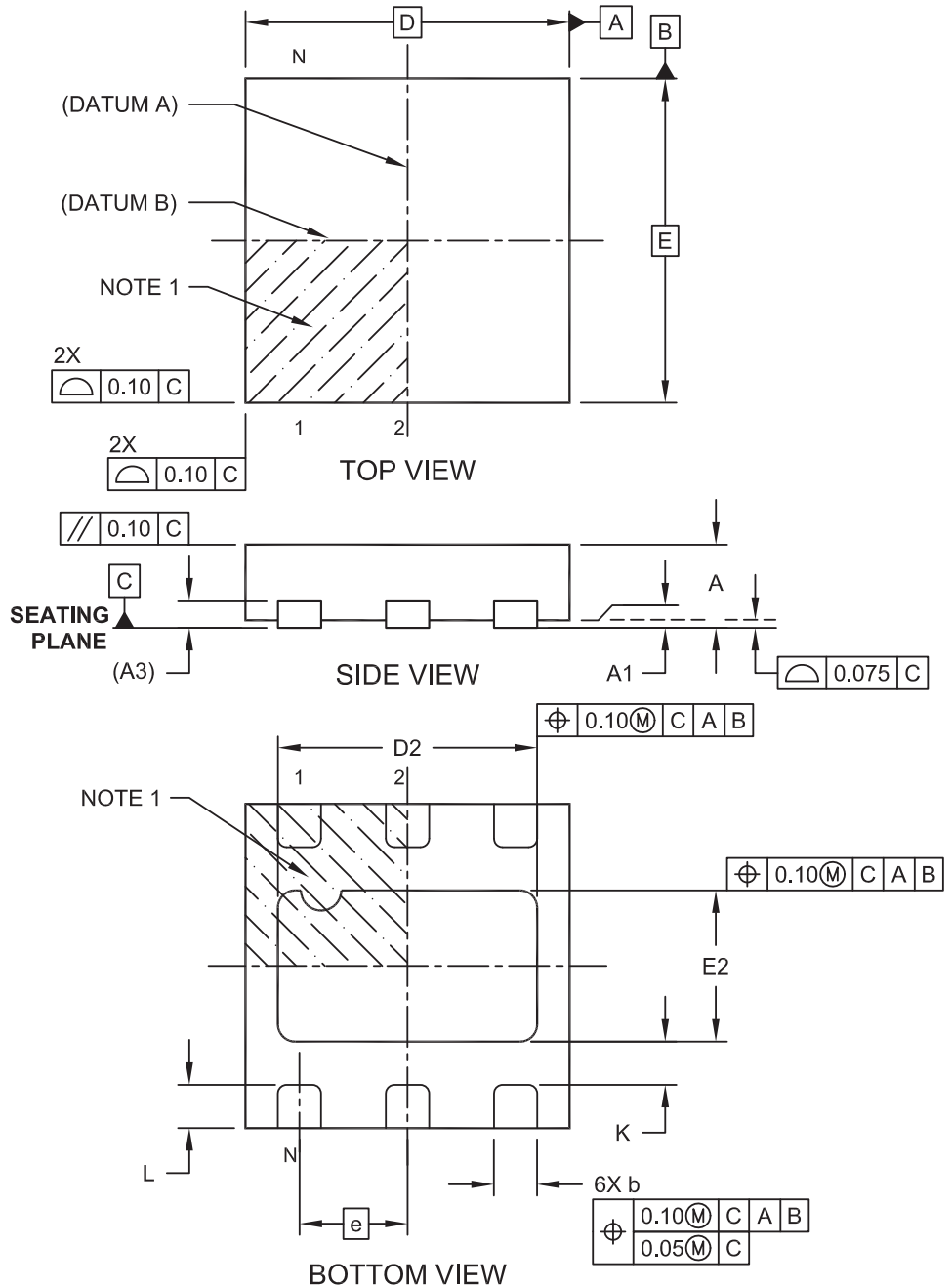


**Note:**

1. Similar to JEDEC JEP95 XQFN/XSON variants, though number of contacts and some dimensions are different.
2. From the bottom view, the pin #1 indicator may be either a curved indent or a 45-degree chamfer.
3. The external paddle is electrically connected to the die back-side and to VSS.  
This paddle must be soldered to the PC board; it is required to connect this paddle to the VSS of the unit.  
Connection of this paddle to any other voltage potential will result in shorts and electrical malfunction of the device.
4. Untoleranced dimensions are nominal target dimensions.
5. All linear dimensions are in millimeters (max/min).

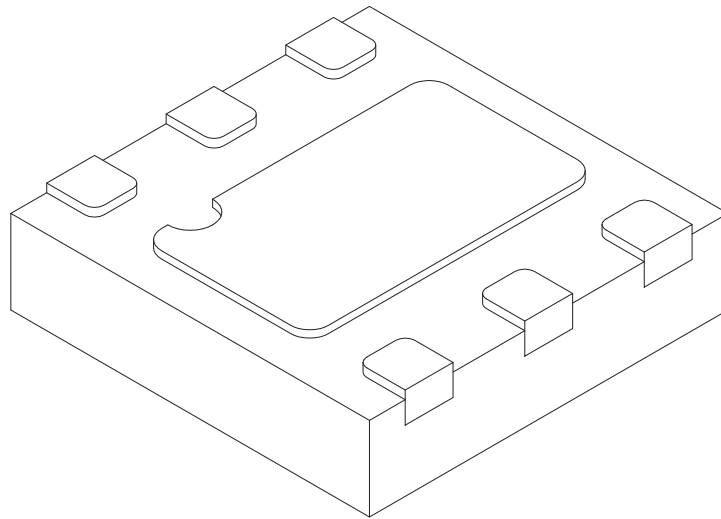
### 6-Lead Plastic Super Thin Small Outline No Lead (NR) - 1.5x1.5x0.4 mm Body [X2SON]

**Note:** For the most current package drawings, please see the Microchip Packaging Specification located at <http://www.microchip.com/packaging>



### 6-Lead Plastic Super Thin Small Outline No Lead (NR) - 1.5x1.5x0.4 mm Body [X2SON]

**Note:** For the most current package drawings, please see the Microchip Packaging Specification located at <http://www.microchip.com/packaging>



Dimension Limits	Units	MILLIMETERS		
		MIN	NOM	MAX
Number of Terminals	N	6		
Pitch	e	0.50 BSC		
Overall Height	A	0.30	0.35	0.40
Standoff	A1	0.00	0.02	0.05
Terminal Thickness	A3	0.127 REF		
Overall Width	E	1.50 BSC		
Exposed Pad Width	E2	0.65	0.70	0.75
Overall Length	D	1.50 BSC		
Exposed Pad Length	D2	1.15	1.20	1.25
Terminal Width	b	0.15	0.20	0.25
Terminal Length	L	0.150	0.200	0.250
Terminal-to-Exposed-Pad	K	0.20	-	-

**Notes:**

1. Pin 1 visual index feature may vary, but must be located within the hatched area.
2. Package is saw singulated
3. Dimensioning and tolerancing per ASME Y14.5M
  - BSC: Basic Dimension. Theoretically exact value shown without tolerances.
  - REF: Reference Dimension, usually without tolerance, for information purposes only.

**Table 6:** Revision History

Revision	Description	Date
00	<ul style="list-style-type: none"> <li>Initial release of data sheet</li> </ul>	Mar 2010
01	<ul style="list-style-type: none"> <li>Revised "Absolute Maximum Stress Ratings" on page 6</li> <li>Changed Operating range to Industrial on page 6</li> <li>Updated Table 4 on page 7</li> <li>Changed document status to "Preliminary Specifications"</li> </ul>	Mar 2010
02	<ul style="list-style-type: none"> <li>Changed document status from "Preliminary Specifications" to "Data Sheet."</li> <li>Made a minor correction in "Product Description" on page 2</li> </ul>	Jul 2010
A	<ul style="list-style-type: none"> <li>Updated Figures 1 and 2</li> <li>Updated Figures 5 and 10 to show measurements with Equalizer Channel Estimation set to "sequence only"</li> <li>Applied new document format</li> <li>Released document under letter revision system</li> <li>Updated Spec number from S71423 to DS75041</li> </ul>	Jan 2012
B	<ul style="list-style-type: none"> <li>Updated package drawing to reflect new Pin1 indicator</li> </ul>	Jul 2012
C	<ul style="list-style-type: none"> <li>Added the X2SON package (package code NR)</li> </ul>	May 2013
D	<ul style="list-style-type: none"> <li>Updated "Features" on page 1 and "Product Description" on page 2</li> <li>Revised Table 5 on page 8</li> <li>Updated package drawings for QX8 and Qx6</li> </ul>	Aug 2014

ISBN:978-1-63276-518-5

© 2014 Microchip Technology Inc.

SST, Silicon Storage Technology, the SST logo, SuperFlash, and MTP are registered trademarks of Microchip Technology, Inc. MPF, SQI, Serial Quad I/O, and Z-Scale are trademarks of Microchip Technology, Inc. All other trademarks and registered trademarks mentioned herein are the property of their respective owners.

Specifications are subject to change without notice. Refer to [www.microchip.com](http://www.microchip.com) for the most recent documentation. For the most current package drawings, please see the Packaging Specification located at <http://www.microchip.com/packaging>.



Memory sizes denote raw storage capacity; actual usable capacity may be less.

Microchip makes no warranty for the use of its products other than those expressly contained in the Standard Terms and Conditions of Sale.

For sales office locations and information, please see [www.microchip.com](http://www.microchip.com).

## Looking for pricing, stock, or lifecycle information?

Click below to explore more details on WIN SOURCE:

-  [View SST12LP19E-QX6E on WIN SOURCE](#)
-  [Microchip Technology](#) Information

## Optimize Your Supply Chain with WIN SOURCE Solutions

-  Global Sourcing Solution
-  Obsolete Management
-  Cost Control Management
-  Shortage Management
-  Alternative Solution
-  Excess Inventory Management