



**THE DATASHEET OF
SN75196N**



- **Single Chip With Easy Interface Between UART and Serial-Port Connector of an External Modem or Other Computer Peripheral**
- **Five Drivers and Three Receivers Meet or Exceed the Requirements of TIA/EIA-232-F and ITU Recommendation V.28**
- **Designed to Support Data Rates up to 120 kbit/s**
- **ESD Protection Meets Or Exceeds 10 kV on RS-232 Pins and 5 kV on All Other Pins (Human-Body Model)**
- **Complement to the SN75185**
- **Pin-to-Pin Replacement for the Goldstar GD75323**
- **Functional Replacement for the MC145405**

**DW OR N PACKAGE
(TOP VIEW)**

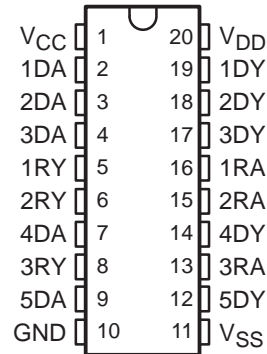

description

The SN75196 combines five drivers and three receivers from the trade-standard SN75188 and SN75189 bipolar quadruple drivers and receivers, respectively. The flow-through design of the SN75196 decreases the part count, reduces the board space required, and allows easy interconnection of the UART and serial-port connector. The all-bipolar circuits and processing of the SN75196 provide a rugged, low-cost solution for this function.

The SN75196 complies with the requirements of TIA/EIA-232-F and ITU (formerly CCITT) V.28 standards. These standards are for data interchange between a host computer and peripheral at signal rates of up to 20 kbit/s. The switching speeds of the SN75196 are fast enough to support rates of up to 120 kbit/s with lower capacitive loads (shorter cables). Interoperability at the higher signaling rates cannot be assured unless the designer has design control of the cable and the interface circuits at both ends. For interoperability at signaling rates of up to 120 kbit/s, use of TIA/EIA-423-B (ITU V.10) and TIA/EIA-422-B (ITU V.11) standards are recommended.

The SN75196 is characterized for operation over a temperature range of 0°C to 70°C.



Please be aware that an important notice concerning availability, standard warranty, and use in critical applications of Texas Instruments semiconductor products and disclaimers thereto appears at the end of this data sheet.

SN75196

MULTIPLE RS-232 DRIVERS AND RECEIVERS

SLLS188B – MAY 1995 – REVISED APRIL 1998

logic symbol†

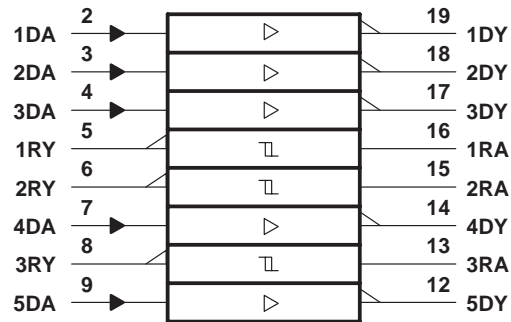

† This symbol is in accordance with ANSI/IEEE Std 91-1984 and IEC Publication 617-12.

logic diagram (positive logic)

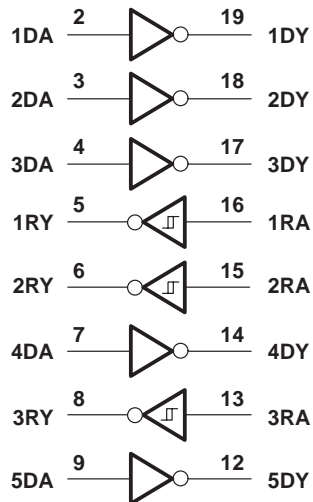

schematic of each driver

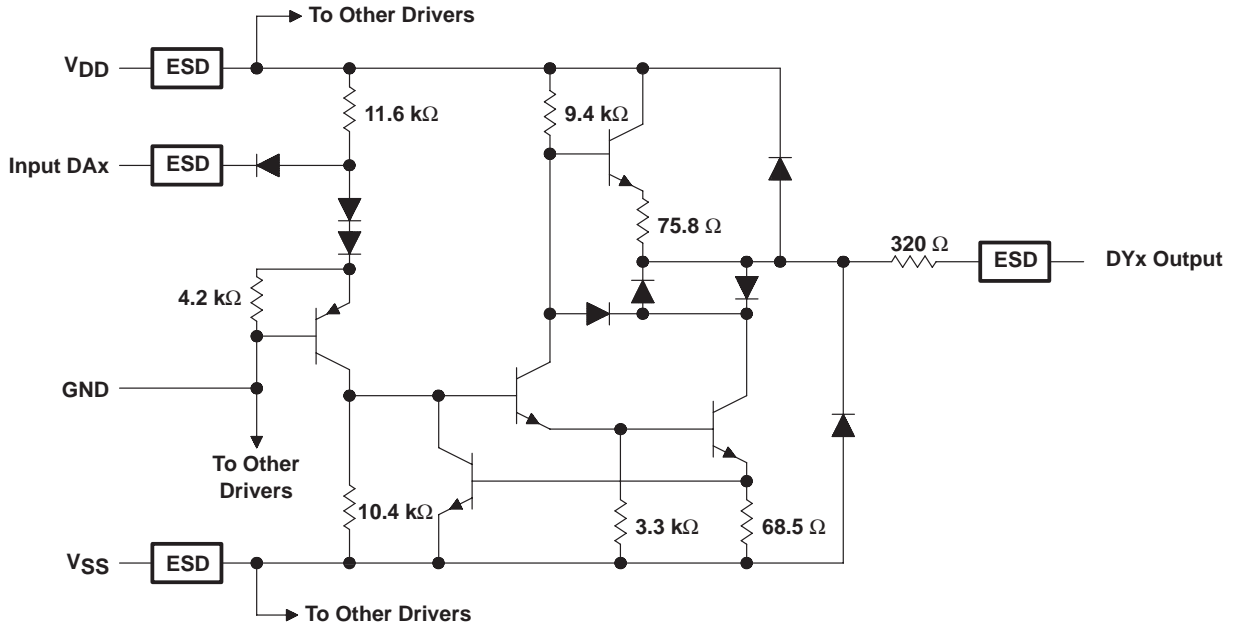

Resistor values shown are nominal.

schematic of each receiver

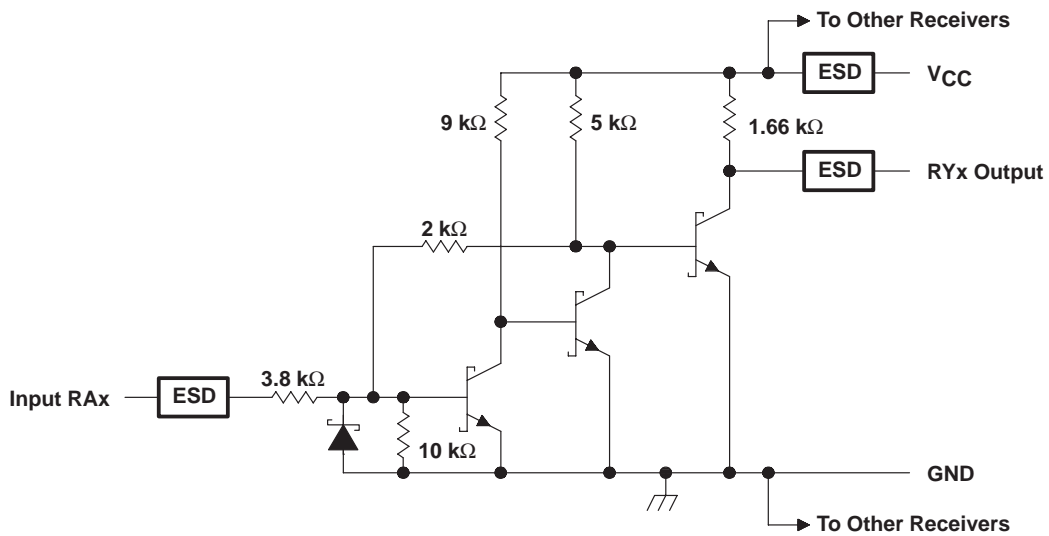

Resistor values shown are nominal.

SN75196 MULTIPLE RS-232 DRIVERS AND RECEIVERS

SLLS188B – MAY 1995 – REVISED APRIL 1998

absolute maximum ratings over operating free-air temperature (unless otherwise noted)†

Supply voltage, V_{CC} (see Note 1)	10 V
Supply voltage, V_{DD} (see Note 1)	15 V
Supply voltage, V_{SS} (see Note 1)	-15 V
Input voltage range, V_i : Driver	-15 V to 7 V
Receiver	-30 V to 30 V
Output voltage range, V_O (Driver)	-15 V to 15 V
Low-level output current, I_{OL} (Receiver)	20 mA
Continuous total power dissipation	See Dissipation Rating Table
Electrostatic discharge: DY and RA to GND (see Note 2)	Class 3, A: 10 kV, B: 500 V
All pins (see Note 2)	Class 3, A: 5 kV, B: 300 V
Storage temperature range, T_{stg}	-65°C to 150°C
Lead temperature 1,6 mm (1/16 inch) from case for 10 seconds	260°C

† Stresses beyond those listed under “absolute maximum ratings” may cause permanent damage to the device. These are stress ratings only, and functional operation of the device at these or any other conditions beyond those indicated under “recommended operating conditions” is not implied. Exposure to absolute-maximum-rated conditions for extended periods may affect device reliability.

- NOTES: 1. All voltages are with respect to the network ground terminal.
2. Per MIL-PRF-38535, Method 3015.7

DISSIPATION RATING TABLE

PACKAGE	$T_A \leq 25^\circ\text{C}$ POWER RATING	DERATING FACTOR‡ ABOVE $T_A = 25^\circ\text{C}$	$T_A = 70^\circ\text{C}$ POWER RATING
DW	1125 mW	9.0 mW/°C	720 mW
N	1150 mW	9.2 mW/°C	736 mW

‡ This is the inverse of the traditional junction-to-case thermal resistance ($R_{\theta JA}$).

recommended operating conditions

		MIN	NOM	MAX	UNIT
Supply voltage, V_{DD}		7.5	9	13.5	V
Supply voltage, V_{SS}		-7.5	-9	-13.5	V
Supply voltage, V_{CC}		4.5	5	5.5	V
High-level input voltage, V_{IH}	Driver	1.9			V
Low-level input voltage, V_{IL}	Driver			0.8	V
High-level output current, I_{OH}	Driver			-6	mA
	Receiver			-0.5	
High-level output current, I_{OL}	Driver			6	mA
	Receiver			16	
Operating free-air temperature, T_A		0		70	°C



supply currents over operating free-air temperature range

PARAMETER		TEST CONDITIONS			MIN	MAX	UNIT
I _{DD}	Supply current from V _{DD}	All inputs at 1.9 V, No load	V _{DD} = 9 V, V _{SS} = -9 V			25	mA
			V _{DD} = 12 V, V _{SS} = -12 V			32	
		All inputs at 0.8 V, No load	V _{DD} = 9 V, V _{SS} = -9 V			7.5	
			V _{DD} = 12 V, V _{SS} = -12 V			9.5	
I _{SS}	Supply current from V _{SS}	All inputs at 1.9 V, No load	V _{DD} = 9 V, V _{SS} = -9 V			-25	mA
			V _{DD} = 12 V, V _{SS} = -12 V			-32	
		All inputs at 0.8 V, No load	V _{DD} = 9 V, V _{SS} = -9 V			-5.3	
			V _{DD} = 12 V, V _{SS} = -12 V			-5.3	
I _{CC}	Supply current from V _{CC}	V _{CC} = 5 V, All inputs at 5 V, No load			20	mA	

DRIVER SECTION

electrical characteristics over operating free-air temperature range, V_{DD} = 9 V, V_{SS} = -9 V, V_{CC} = 5 V, (unless otherwise noted)

PARAMETER		TEST CONDITIONS			MIN	TYP	MAX	UNIT
V _{OH}	High-level output voltage	V _{IL} = 0.8 V, R _L = 3 kΩ, See Figure 1			6	7.5		V
V _{OL}	Low-level output voltage (see Note 3)	V _{IH} = 1.9 V, R _L = 3 kΩ, See Figure 1				-7.5	-6	V
I _{IH}	High-level input current	V _I = 5 V, See Figure 2					10	μA
I _{IL}	Low-level input current	V _I = 0, See Figure 2					-1.6	mA
I _{OS(H)}	High-level short-circuit output current (see Note 4)	V _{IL} = 0.8 V, V _O = 0, See Figure 1			-4.5	-9	-19.5	mA
I _{OS(L)}	Low-level short-circuit output current (see Note 4)	V _{IH} = 2 V, V _O = 0, See Figure 1			4.5	9	19.5	mA
r _o	Output resistance (see Note 5)	V _{CC} = V _{DD} = V _{SS} = 0, V _O = -2 V to 2 V			300			Ω

- NOTES: 3. The algebraic convention, where the more positive (less negative) limit is designated as maximum, is used in this data sheet for logic levels only, e.g., if -10 V is a maximum, the typical value is a more negative voltage.
 4. Output short-circuit conditions must maintain the total power dissipation below absolute maximum ratings.
 5. Test conditions are those specified by TIA/EIA-232-F and as listed above.

switching characteristics, V_{DD} = 12 V, V_{SS} = -12 V, V_{CC} = 5 V ±10%, T_A = 25°C

PARAMETER		TEST CONDITIONS			MIN	TYP	MAX	UNIT
t _{PLH}	Propagation delay time, low- to high-level output	R _L = 3 kΩ to 7 kΩ, C _L = 15 pF, See Figure 3				315	500	ns
t _{PHL}	Propagation delay time, high- to low-level output	R _L = 3 kΩ to 7 kΩ, C _L = 15 pF, See Figure 3				75	175	ns
t _{TLH}	Transition time, low- to high-level output (see Note 6)	R _L = 3 kΩ to 7 kΩ	C _L = 15 pF, See Figure 3			60	100	ns
			C _L = 2500 pF, See Figure 3 and Note 6			1.7	2.5	μs
t _{THL}	Transition time, high- to low-level output (see Note 7)	R _L = 3 kΩ to 7 kΩ	C _L = 15 pF, See Figure 3			40	75	ns
			C _L = 2500 pF, See Figure 3 and Note 7			1.5	2.5	μs

- NOTES: 6. Measured between -3-V and 3-V points of the output waveform (TIA/EIA-232-F conditions), all unused inputs are tied either high or low.
 7. Measured between 3-V and -3-V points of the output waveform (TIA/EIA-232-F conditions), all unused inputs are tied either high or low.

SN75196 MULTIPLE RS-232 DRIVERS AND RECEIVERS

SLLS188B – MAY 1995 – REVISED APRIL 1998

RECEIVER SECTION

electrical characteristics over recommended operating conditions (unless otherwise noted)

PARAMETER		TEST CONDITIONS		MIN	TYP†	MAX	UNIT
V _{IT+}	Positive-going input threshold voltage	See Figure 5	T _A = 25°C	1.75	1.9	2.3	V
			T _A = 0°C to 70 °C	1.55		2.3	
V _{IT-}	Negative-going input threshold voltage	See Figure 5		0.75	0.97	1.25	V
V _{hys}	Input hysteresis (V _{IT+} - V _{IT-})	See Figure 5		0.5			V
V _{OH}	High-level output voltage	I _{OH} = -0.5 mA, See Figure 5	V _{IH} = 0.75 V	2.6	4	5	V
			Inputs open	2.6			
V _{OL}	Low-level input voltage	I _{OL} = 10 mA, V _I = 3 V, See Figure 5			0.2	0.45	V
I _{IH}	High-level input current	V _I = 25 V		3.6		8.3	mA
		V _I = 3 V		0.43			
I _{IL}	Low-level input current	V _I = -25 V		-3.6		-8.3	mA
		V _I = -3 V		-0.43			
I _{OS}	Short-circuit output current	See Figure 4		-3.4		-12	mA

† All typical values are at T_A = 25°C, V_{CC} = 5 V, V_{DD} = 9 V, and V_{SS} = -9 V.

switching characteristics, V_{CC} = 5 V, V_{DD} = 12 V, V_{SS} = -12 V, T_A = 25°C

PARAMETER		TEST CONDITIONS		MIN	TYP	MAX	UNIT
t _{PLH}	Propagation delay time, low- to high-level output	C _L = 50 pF, R _L = 5 kΩ, See Figure 6			107	500	ns
t _{PHL}	Propagation delay time, high- to low-level output	C _L = 50 pF, R _L = 5 kΩ, See Figure 6			42	150	ns
t _{T LH}	Transition time, low- to high-level output	C _L = 50 pF, R _L = 5 kΩ, See Figure 6			175	525	ns
t _{T HL}	Transition time, high- to low-level output	C _L = 50 pF, R _L = 5 kΩ, See Figure 6			16	60	ns



PARAMETER MEASUREMENT INFORMATION

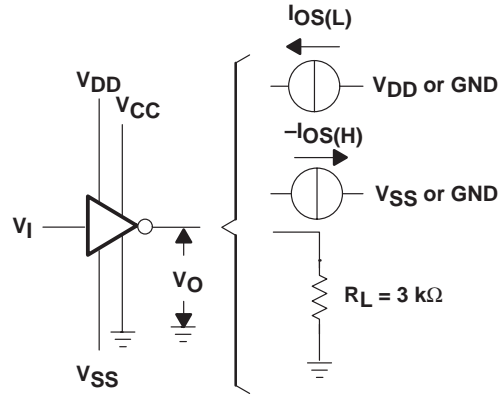

Figure 1. Driver Test Circuit for V_{OH} , V_{OL} , $I_{OS(H)}$, and $I_{OS(L)}$

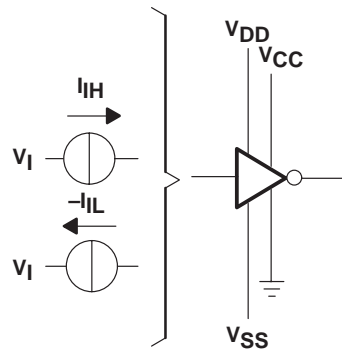
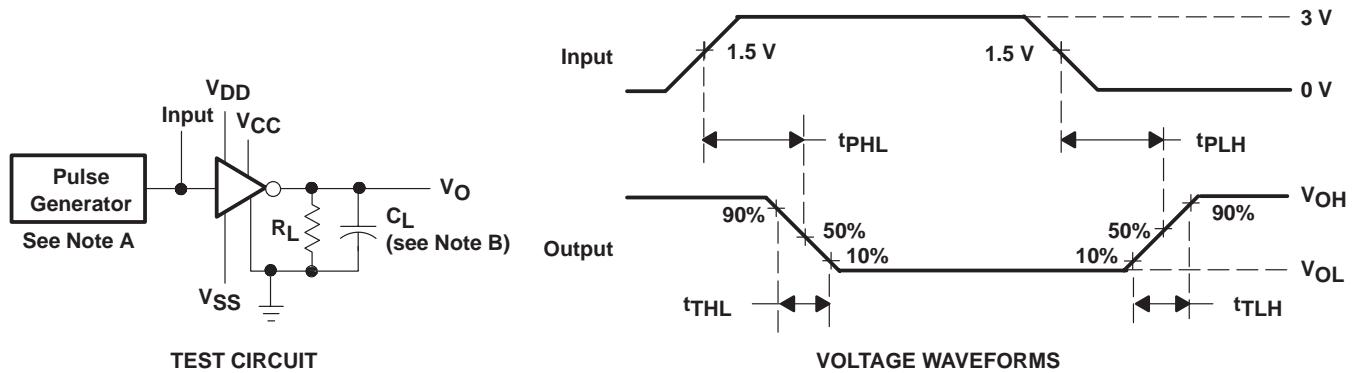

Figure 2. Driver Test Circuit for I_{IH} and I_{IL}



- NOTES: A. The pulse generator has the following characteristics: $t_w = 25\ \mu\text{s}$, $\text{PRR} = 20\ \text{kHz}$, $Z_O = 50\ \Omega$, $t_r = t_f < 50\ \text{ns}$.
 B. C_L includes probe and jig capacitance.

Figure 3. Driver Test Circuit and Voltage Waveforms

SN75196 MULTIPLE RS-232 DRIVERS AND RECEIVERS

SLLS188B – MAY 1995 – REVISED APRIL 1998

PARAMETER MEASUREMENT INFORMATION

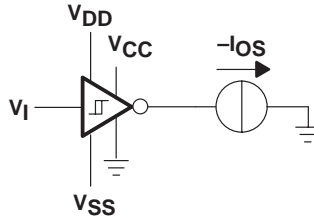

Figure 4. Receiver Test Circuit for I_{OS}

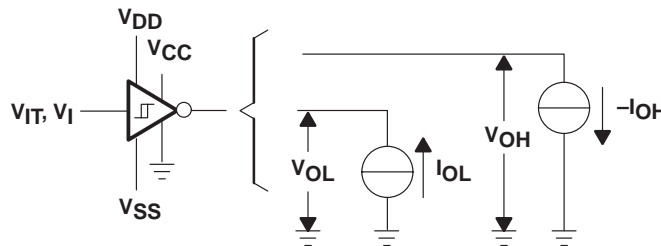
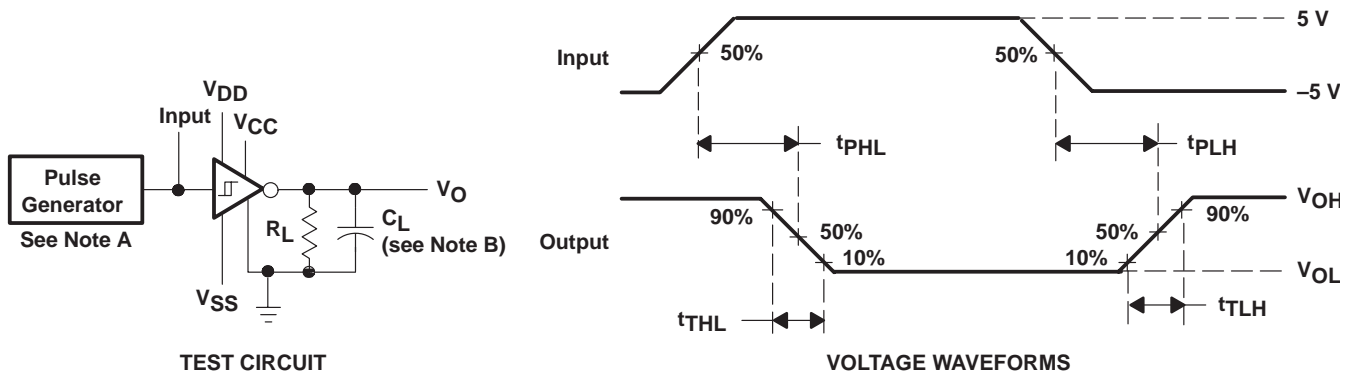

Figure 5. Receiver Test Circuit for V_{IT} , V_{OH} , and V_{OL}



- NOTES: A. The pulse generator has the following characteristics: $t_w = 25 \mu s$, $PRR = 20 \text{ kHz}$, $Z_O = 50 \Omega$, $t_r = t_f < 50 \text{ ns}$.
B. C_L includes probe and jig capacitance.

Figure 6. Receiver Propagation and Transition Times

TYPICAL CHARACTERISTICS

DRIVER SECTION

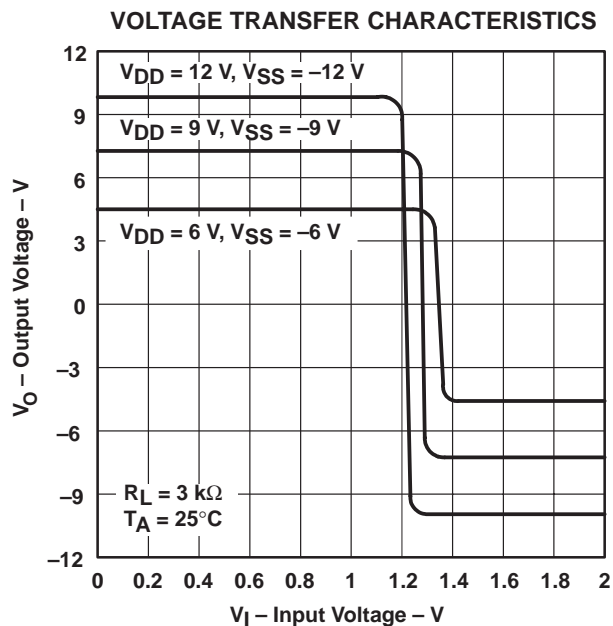

Figure 7

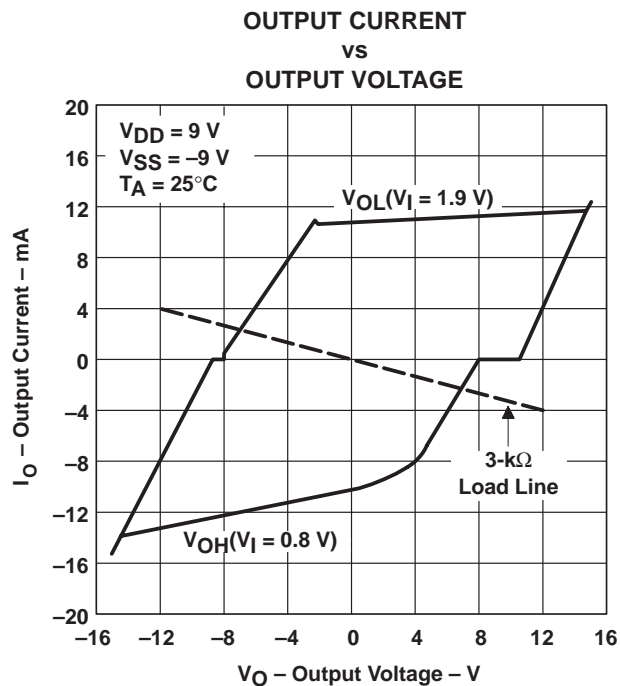

Figure 8

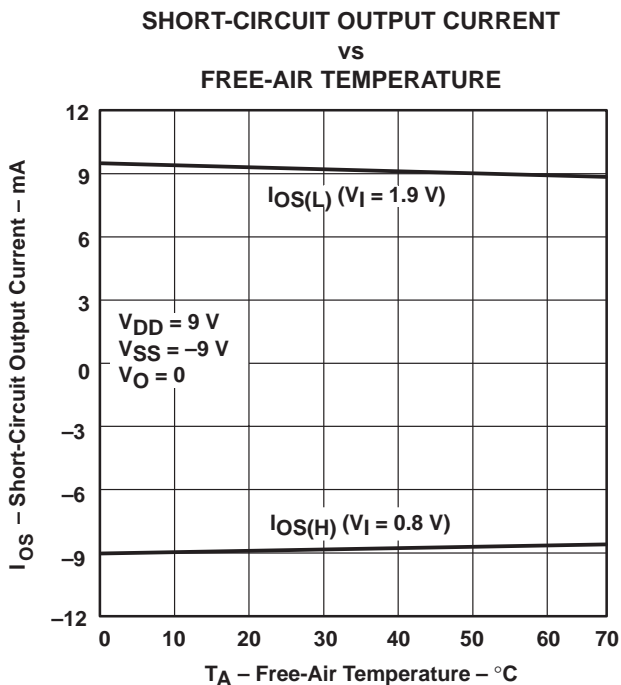

Figure 9

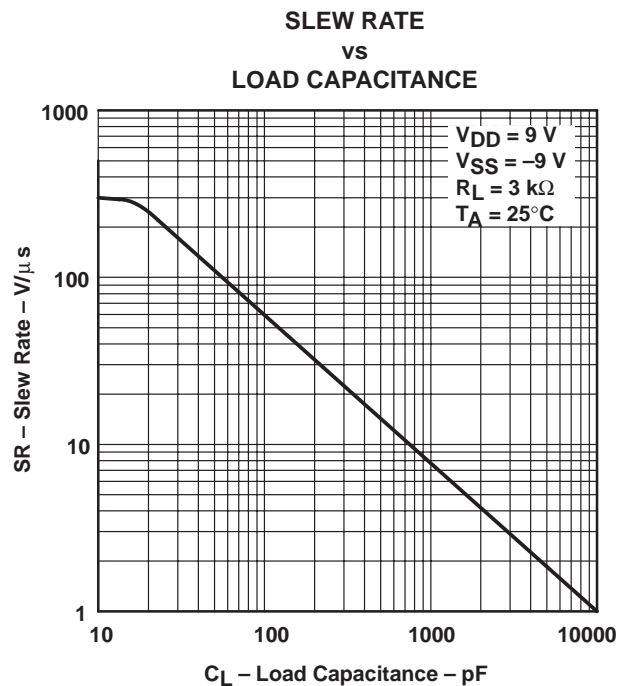

Figure 10

TYPICAL CHARACTERISTICS
 RECEIVER SECTION

INPUT THRESHOLD VOLTAGE
 vs
 FREE-AIR TEMPERATURE

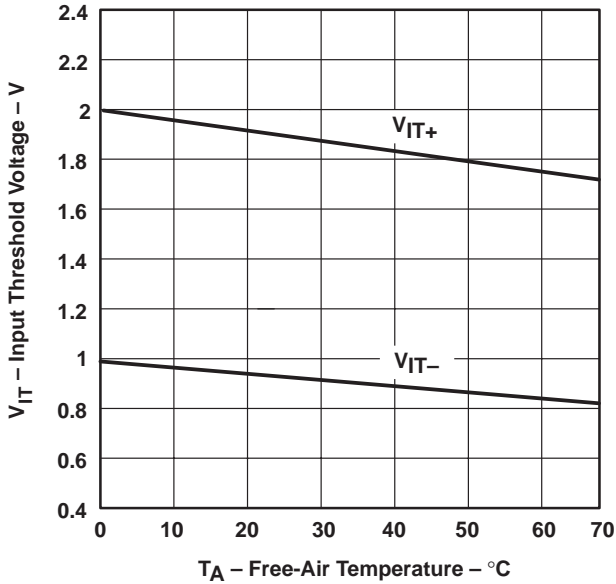

Figure 11

INPUT THRESHOLD VOLTAGE
 vs
 SUPPLY VOLTAGE

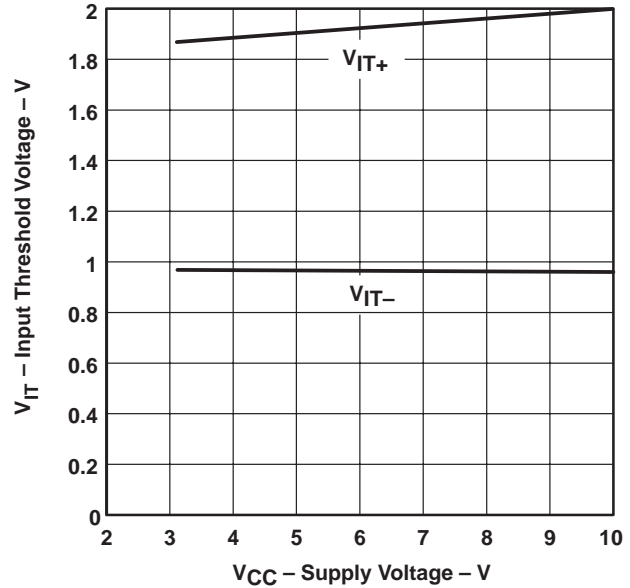
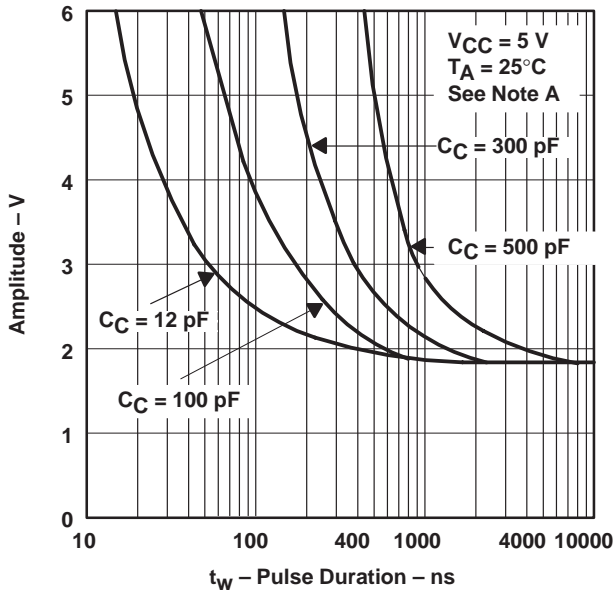

Figure 12

NOISE REJECTION



NOTE A: This figure shows the maximum amplitude of a positive-going pulse that, starting from 0 V, does not cause a change of the output level.

Figure 13

MAXIMUM SUPPLY VOLTAGE
 vs
 FREE-AIR TEMPERATURE

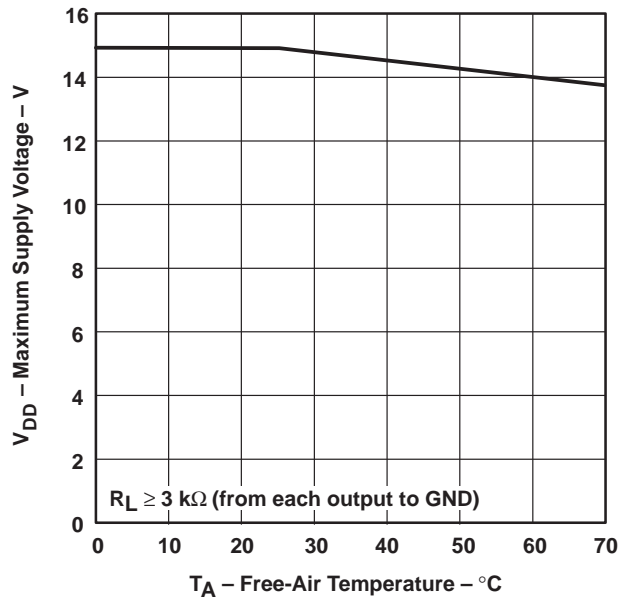

Figure 14

APPLICATION INFORMATION

Diodes placed in series with the V_{DD} and V_{SS} terminals protect the SN75196 in the fault condition when the device outputs are shorted to V_{DD} or V_{SS} and the power supplies are at low and provide low-impedance paths to ground (see Figure 15).

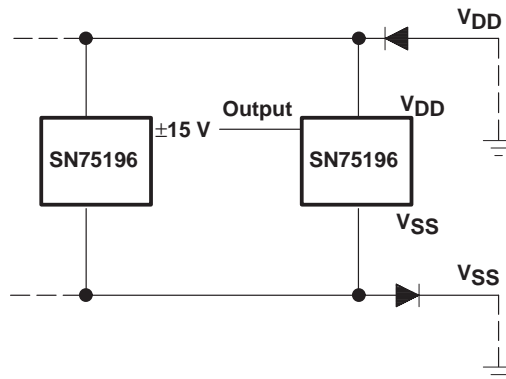
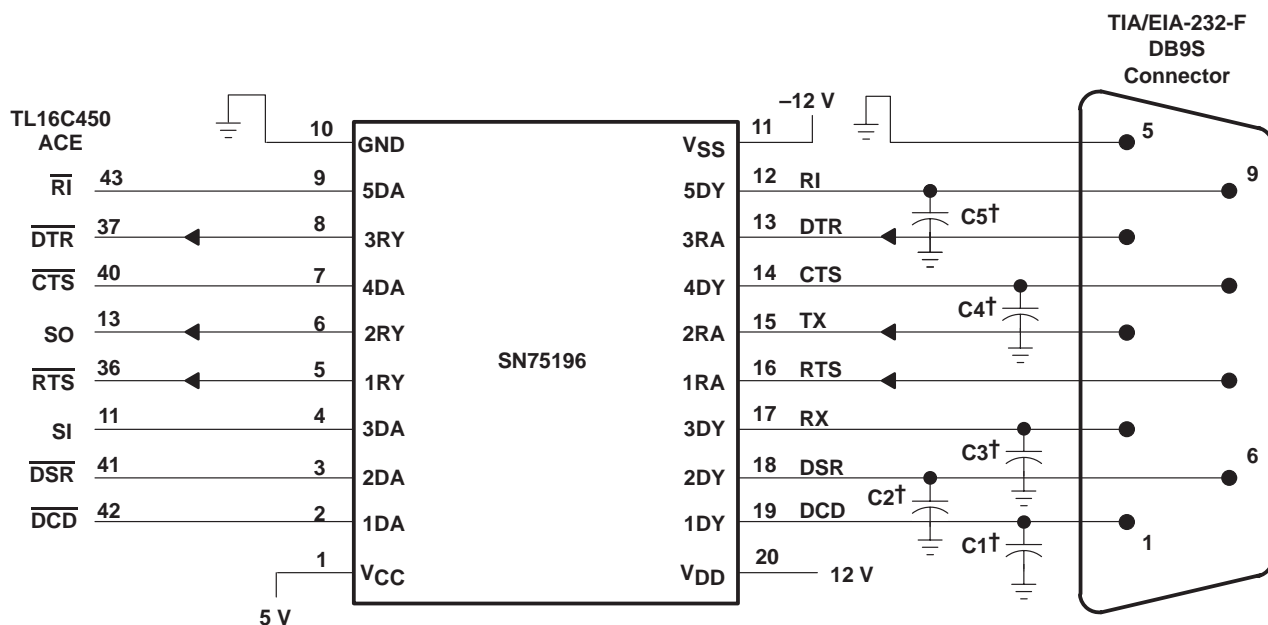

Figure 15. Power-Supply Protection to Meet Power-Off Fault Conditions of TIA/EIA-232-F



† See Figure 10 to select the correct values for the loading capacitors (C1, C2, C3, C4, and C5), which may be required to meet the RS-232 maximum slew-rate requirement of 30 V/μs. The value of the loading capacitors required depends upon the line length and desired slew rate, but is typically 330 pF.

NOTE A: To use the receivers only, V_{DD} and V_{SS} must both be powered or tied to ground.

Figure 16. Typical TIA/EIA-232-F Connection

PACKAGING INFORMATION

Orderable Device	Status (1)	Package Type	Package Drawing	Pins	Package Qty	Eco Plan (2)	Lead/Ball Finish (6)	MSL Peak Temp (3)	Op Temp (°C)	Device Marking (4/5)	Samples
SN75196DW	ACTIVE	SOIC	DW	20	25	Green (RoHS & no Sb/Br)	CU NIPDAU	Level-1-260C-UNLIM	0 to 70	SN75196	Samples
SN75196DWR	ACTIVE	SOIC	DW	20	2000	Green (RoHS & no Sb/Br)	CU NIPDAU	Level-1-260C-UNLIM	0 to 70	SN75196	Samples

(1) The marketing status values are defined as follows:

ACTIVE: Product device recommended for new designs.

LIFEBUY: TI has announced that the device will be discontinued, and a lifetime-buy period is in effect.

NRND: Not recommended for new designs. Device is in production to support existing customers, but TI does not recommend using this part in a new design.

PREVIEW: Device has been announced but is not in production. Samples may or may not be available.

OBSOLETE: TI has discontinued the production of the device.

(2) **RoHS:** TI defines "RoHS" to mean semiconductor products that are compliant with the current EU RoHS requirements for all 10 RoHS substances, including the requirement that RoHS substance do not exceed 0.1% by weight in homogeneous materials. Where designed to be soldered at high temperatures, "RoHS" products are suitable for use in specified lead-free processes. TI may reference these types of products as "Pb-Free".

RoHS Exempt: TI defines "RoHS Exempt" to mean products that contain lead but are compliant with EU RoHS pursuant to a specific EU RoHS exemption.

Green: TI defines "Green" to mean the content of Chlorine (Cl) and Bromine (Br) based flame retardants meet JS709B low halogen requirements of <=1000ppm threshold. Antimony trioxide based flame retardants must also meet the <=1000ppm threshold requirement.

(3) MSL, Peak Temp. - The Moisture Sensitivity Level rating according to the JEDEC industry standard classifications, and peak solder temperature.

(4) There may be additional marking, which relates to the logo, the lot trace code information, or the environmental category on the device.

(5) Multiple Device Markings will be inside parentheses. Only one Device Marking contained in parentheses and separated by a "~" will appear on a device. If a line is indented then it is a continuation of the previous line and the two combined represent the entire Device Marking for that device.

(6) Lead/Ball Finish - Orderable Devices may have multiple material finish options. Finish options are separated by a vertical ruled line. Lead/Ball Finish values may wrap to two lines if the finish value exceeds the maximum column width.

Important Information and Disclaimer:The information provided on this page represents TI's knowledge and belief as of the date that it is provided. TI bases its knowledge and belief on information provided by third parties, and makes no representation or warranty as to the accuracy of such information. Efforts are underway to better integrate information from third parties. TI has taken and continues to take reasonable steps to provide representative and accurate information but may not have conducted destructive testing or chemical analysis on incoming materials and chemicals. TI and TI suppliers consider certain information to be proprietary, and thus CAS numbers and other limited information may not be available for release.

In no event shall TI's liability arising out of such information exceed the total purchase price of the TI part(s) at issue in this document sold by TI to Customer on an annual basis.

TAPE AND REEL INFORMATION

REEL DIMENSIONS

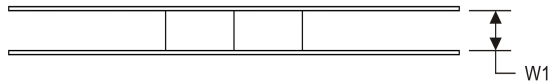
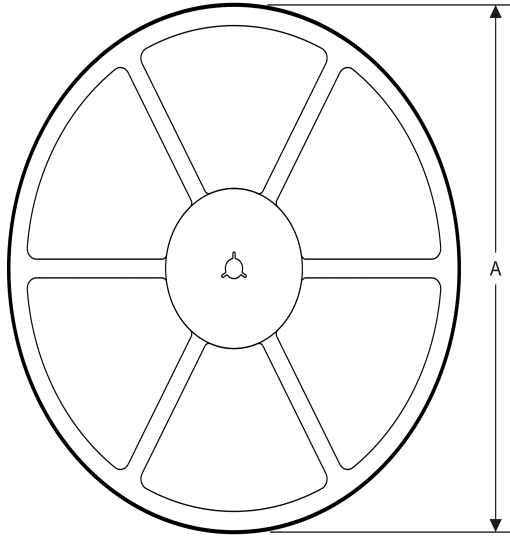

TAPE DIMENSIONS

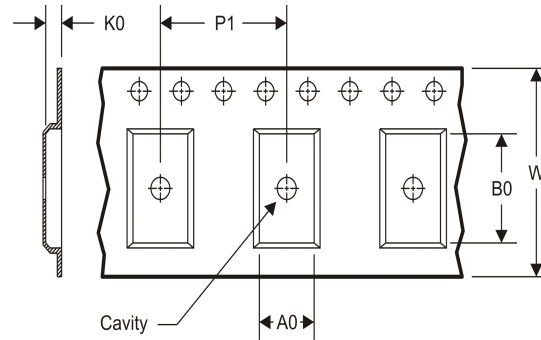

A0	Dimension designed to accommodate the component width
B0	Dimension designed to accommodate the component length
K0	Dimension designed to accommodate the component thickness
W	Overall width of the carrier tape
P1	Pitch between successive cavity centers

TAPE AND REEL INFORMATION

*All dimensions are nominal

Device	Package Type	Package Drawing	Pins	SPQ	Reel Diameter (mm)	Reel Width W1 (mm)	A0 (mm)	B0 (mm)	K0 (mm)	P1 (mm)	W (mm)	Pin1 Quadrant
SN75196DWR	SOIC	DW	20	2000	330.0	24.4	10.8	13.0	2.7	12.0	24.0	Q1

TAPE AND REEL BOX DIMENSIONS



*All dimensions are nominal

Device	Package Type	Package Drawing	Pins	SPQ	Length (mm)	Width (mm)	Height (mm)
SN75196DWR	SOIC	DW	20	2000	367.0	367.0	45.0

EXAMPLE BOARD LAYOUT

DW0020A

SOIC - 2.65 mm max height

SOIC



LAND PATTERN EXAMPLE
SCALE:6X

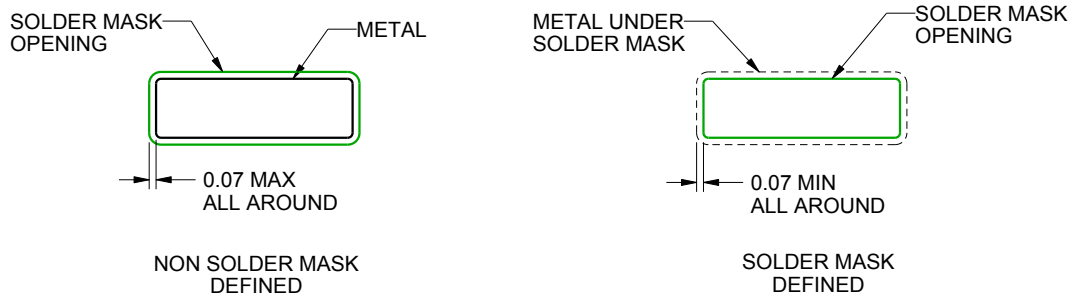

SOLDER MASK DETAILS

4220724/A 05/2016

NOTES: (continued)

- 6. Publication IPC-7351 may have alternate designs.
- 7. Solder mask tolerances between and around signal pads can vary based on board fabrication site.

EXAMPLE STENCIL DESIGN

DW0020A

SOIC - 2.65 mm max height

SOIC



SOLDER PASTE EXAMPLE
BASED ON 0.125 mm THICK STENCIL
SCALE:6X

4220724/A 05/2016

NOTES: (continued)

- 8. Laser cutting apertures with trapezoidal walls and rounded corners may offer better paste release. IPC-7525 may have alternate design recommendations.
- 9. Board assembly site may have different recommendations for stencil design.

IMPORTANT NOTICE

Texas Instruments Incorporated (TI) reserves the right to make corrections, enhancements, improvements and other changes to its semiconductor products and services per JESD46, latest issue, and to discontinue any product or service per JESD48, latest issue. Buyers should obtain the latest relevant information before placing orders and should verify that such information is current and complete.

TI's published terms of sale for semiconductor products (<http://www.ti.com/sc/docs/stdterms.htm>) apply to the sale of packaged integrated circuit products that TI has qualified and released to market. Additional terms may apply to the use or sale of other types of TI products and services.

Reproduction of significant portions of TI information in TI data sheets is permissible only if reproduction is without alteration and is accompanied by all associated warranties, conditions, limitations, and notices. TI is not responsible or liable for such reproduced documentation. Information of third parties may be subject to additional restrictions. Resale of TI products or services with statements different from or beyond the parameters stated by TI for that product or service voids all express and any implied warranties for the associated TI product or service and is an unfair and deceptive business practice. TI is not responsible or liable for any such statements.

Buyers and others who are developing systems that incorporate TI products (collectively, "Designers") understand and agree that Designers remain responsible for using their independent analysis, evaluation and judgment in designing their applications and that Designers have full and exclusive responsibility to assure the safety of Designers' applications and compliance of their applications (and of all TI products used in or for Designers' applications) with all applicable regulations, laws and other applicable requirements. Designer represents that, with respect to their applications, Designer has all the necessary expertise to create and implement safeguards that (1) anticipate dangerous consequences of failures, (2) monitor failures and their consequences, and (3) lessen the likelihood of failures that might cause harm and take appropriate actions. Designer agrees that prior to using or distributing any applications that include TI products, Designer will thoroughly test such applications and the functionality of such TI products as used in such applications.

TI's provision of technical, application or other design advice, quality characterization, reliability data or other services or information, including, but not limited to, reference designs and materials relating to evaluation modules, (collectively, "TI Resources") are intended to assist designers who are developing applications that incorporate TI products; by downloading, accessing or using TI Resources in any way, Designer (individually or, if Designer is acting on behalf of a company, Designer's company) agrees to use any particular TI Resource solely for this purpose and subject to the terms of this Notice.

TI's provision of TI Resources does not expand or otherwise alter TI's applicable published warranties or warranty disclaimers for TI products, and no additional obligations or liabilities arise from TI providing such TI Resources. TI reserves the right to make corrections, enhancements, improvements and other changes to its TI Resources. TI has not conducted any testing other than that specifically described in the published documentation for a particular TI Resource.

Designer is authorized to use, copy and modify any individual TI Resource only in connection with the development of applications that include the TI product(s) identified in such TI Resource. NO OTHER LICENSE, EXPRESS OR IMPLIED, BY ESTOPPEL OR OTHERWISE TO ANY OTHER TI INTELLECTUAL PROPERTY RIGHT, AND NO LICENSE TO ANY TECHNOLOGY OR INTELLECTUAL PROPERTY RIGHT OF TI OR ANY THIRD PARTY IS GRANTED HEREIN, including but not limited to any patent right, copyright, mask work right, or other intellectual property right relating to any combination, machine, or process in which TI products or services are used. Information regarding or referencing third-party products or services does not constitute a license to use such products or services, or a warranty or endorsement thereof. Use of TI Resources may require a license from a third party under the patents or other intellectual property of the third party, or a license from TI under the patents or other intellectual property of TI.

TI RESOURCES ARE PROVIDED "AS IS" AND WITH ALL FAULTS. TI DISCLAIMS ALL OTHER WARRANTIES OR REPRESENTATIONS, EXPRESS OR IMPLIED, REGARDING RESOURCES OR USE THEREOF, INCLUDING BUT NOT LIMITED TO ACCURACY OR COMPLETENESS, TITLE, ANY EPIDEMIC FAILURE WARRANTY AND ANY IMPLIED WARRANTIES OF MERCHANTABILITY, FITNESS FOR A PARTICULAR PURPOSE, AND NON-INFRINGEMENT OF ANY THIRD PARTY INTELLECTUAL PROPERTY RIGHTS. TI SHALL NOT BE LIABLE FOR AND SHALL NOT DEFEND OR INDEMNIFY DESIGNER AGAINST ANY CLAIM, INCLUDING BUT NOT LIMITED TO ANY INFRINGEMENT CLAIM THAT RELATES TO OR IS BASED ON ANY COMBINATION OF PRODUCTS EVEN IF DESCRIBED IN TI RESOURCES OR OTHERWISE. IN NO EVENT SHALL TI BE LIABLE FOR ANY ACTUAL, DIRECT, SPECIAL, COLLATERAL, INDIRECT, PUNITIVE, INCIDENTAL, CONSEQUENTIAL OR EXEMPLARY DAMAGES IN CONNECTION WITH OR ARISING OUT OF TI RESOURCES OR USE THEREOF, AND REGARDLESS OF WHETHER TI HAS BEEN ADVISED OF THE POSSIBILITY OF SUCH DAMAGES.

Unless TI has explicitly designated an individual product as meeting the requirements of a particular industry standard (e.g., ISO/TS 16949 and ISO 26262), TI is not responsible for any failure to meet such industry standard requirements.

Where TI specifically promotes products as facilitating functional safety or as compliant with industry functional safety standards, such products are intended to help enable customers to design and create their own applications that meet applicable functional safety standards and requirements. Using products in an application does not by itself establish any safety features in the application. Designers must ensure compliance with safety-related requirements and standards applicable to their applications. Designer may not use any TI products in life-critical medical equipment unless authorized officers of the parties have executed a special contract specifically governing such use. Life-critical medical equipment is medical equipment where failure of such equipment would cause serious bodily injury or death (e.g., life support, pacemakers, defibrillators, heart pumps, neurostimulators, and implantables). Such equipment includes, without limitation, all medical devices identified by the U.S. Food and Drug Administration as Class III devices and equivalent classifications outside the U.S.

TI may expressly designate certain products as completing a particular qualification (e.g., Q100, Military Grade, or Enhanced Product). Designers agree that it has the necessary expertise to select the product with the appropriate qualification designation for their applications and that proper product selection is at Designers' own risk. Designers are solely responsible for compliance with all legal and regulatory requirements in connection with such selection.

Designer will fully indemnify TI and its representatives against any damages, costs, losses, and/or liabilities arising out of Designer's non-compliance with the terms and provisions of this Notice.

Looking for pricing, stock, or lifecycle information?

Click below to explore more details on WIN SOURCE:

 [View SN75196N on WIN SOURCE](#)

 [Texas Instruments](#) Information

Optimize Your Supply Chain with WIN SOURCE Solutions

-  Global Sourcing Solution
-  Obsolete Management
-  Cost Control Management
-  Shortage Management
-  Alternative Solution
-  Excess Inventory Management