



**THE DATASHEET OF
HEF4538BP,652**



HEF4538B

Dual precision monostable multivibrator

Rev. 11 — 19 October 2018

Product data sheet

1. General description

The HEF4538B is a dual retriggerable-resettable monostable multivibrator. Each multivibrator has an active LOW trigger/retrigger input ($n\bar{A}$), an active HIGH trigger/retrigger input (nB), an overriding active LOW direct reset input ($n\bar{C}\bar{D}$), an output (nQ) and its complement ($n\bar{Q}$), and two pins (nR_{EXT}/C_{EXT} , and nC_{EXT} , always connected to ground) for connecting the external timing components C_{EXT} and R_{EXT} . Typical pulse width variation over the specified temperature range is $\pm 0.2\%$.

The multivibrator may be triggered by either the positive or the negative edges of the input pulse and will produce an accurate output pulse with a pulse width range of 10 μs to infinity. The duration and accuracy of the output pulse are determined by the external timing components C_{EXT} and R_{EXT} . The output pulse width (t_W) is equal to $R_{EXT} \times C_{EXT}$. The linear design techniques in LOC MOS (Local Oxide CMOS) guarantee precise control of the output pulse width. A LOW level at $n\bar{C}\bar{D}$ terminates the output pulse immediately. The trigger inputs' Schmitt trigger action makes the circuit highly tolerant of slower rise and fall times.

It operates over a recommended V_{DD} power supply range of 3 V to 15 V referenced to V_{SS} (usually ground). Unused inputs must be connected to V_{DD} , V_{SS} , or another input.

2. Features and benefits

- Tolerant of slow trigger rise and fall times
- Fully static operation
- 5 V, 10 V, and 15 V parametric ratings
- Standardized symmetrical output characteristics
- Specified from $-40\text{ }^\circ\text{C}$ to $+85\text{ }^\circ\text{C}$ and $-40\text{ }^\circ\text{C}$ to $+125\text{ }^\circ\text{C}$
- Complies with JEDEC standard JESD 13-B

3. Ordering information

Table 1. Ordering information

Type number	Package			
	Temperature range	Name	Description	Version
HEF4538BT	$-40\text{ }^\circ\text{C}$ to $+125\text{ }^\circ\text{C}$	SO16	plastic small outline package; 16 leads; body width 3.9 mm	SOT109-1

4. Functional diagram

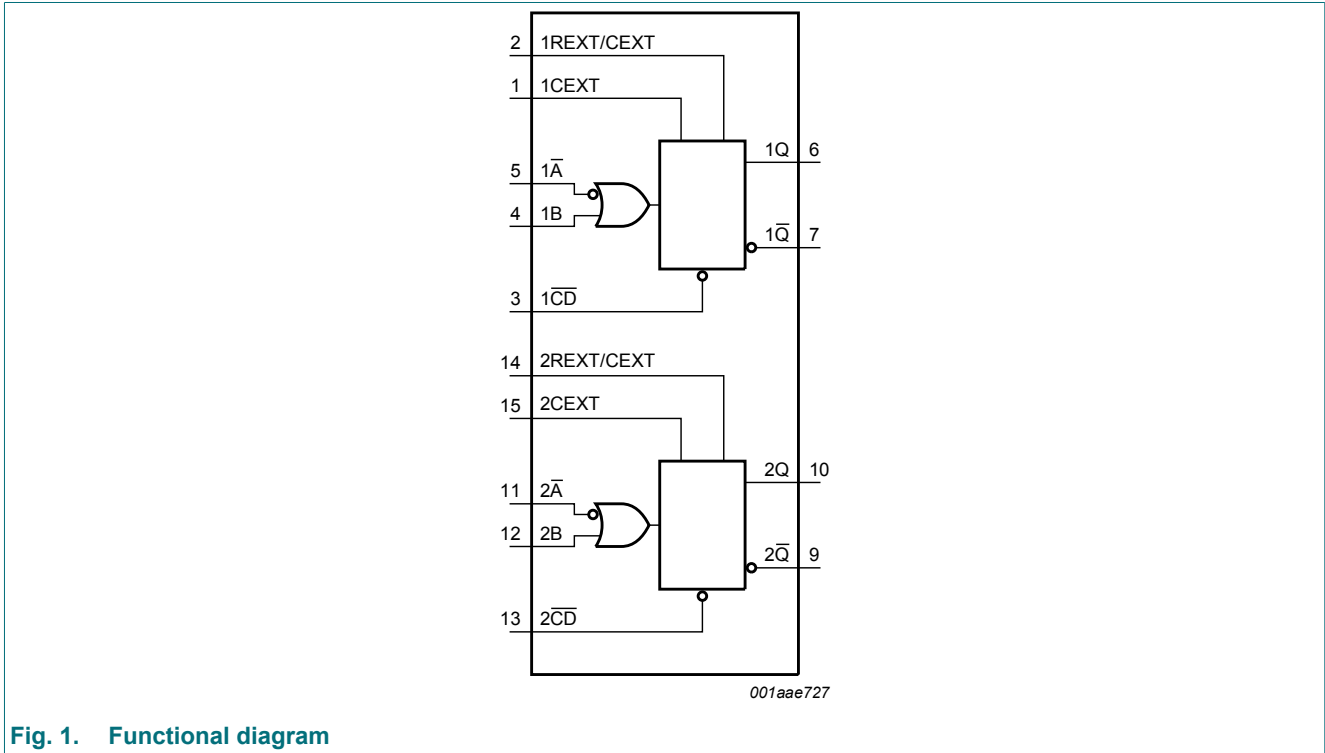

Fig. 1. Functional diagram

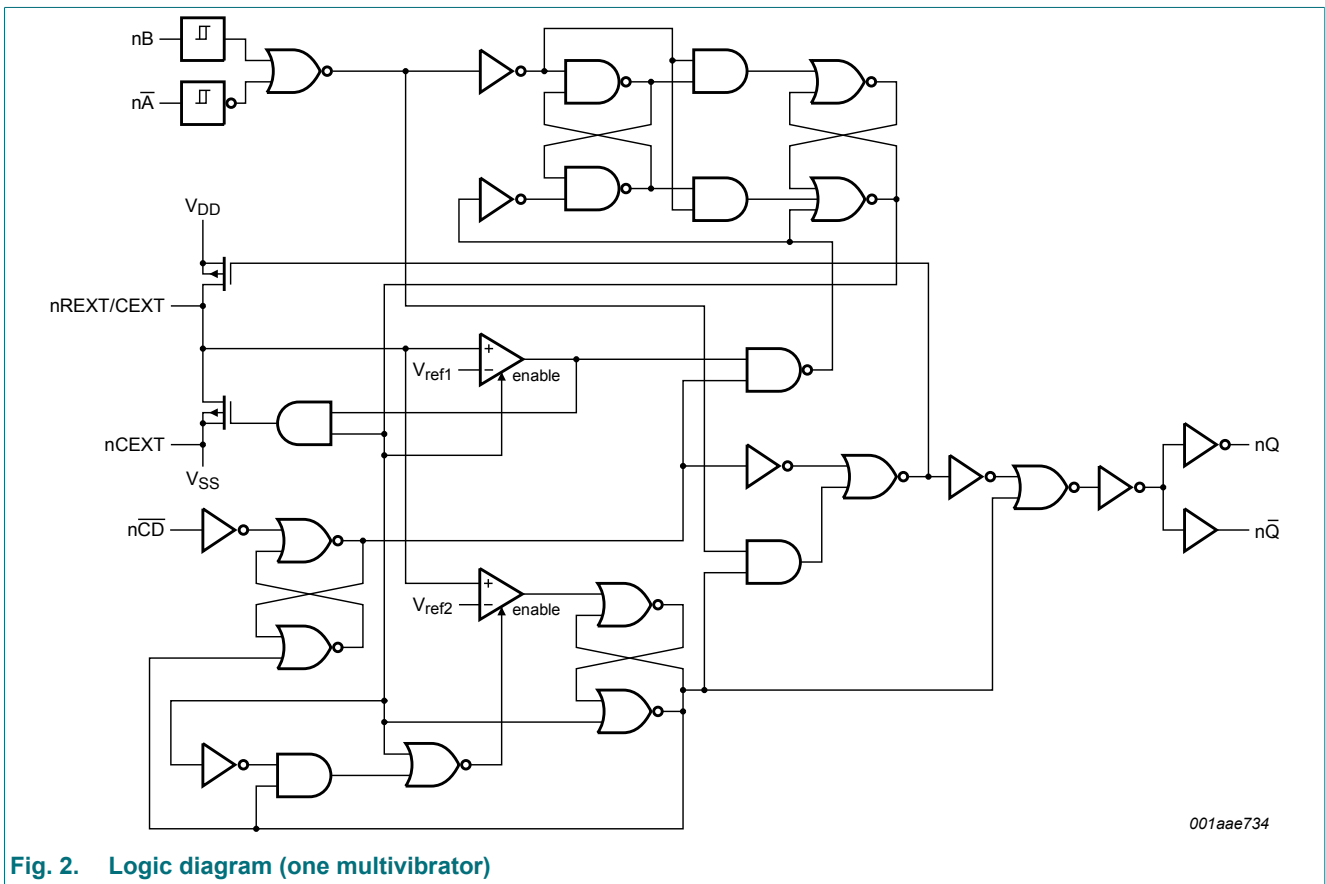

Fig. 2. Logic diagram (one multivibrator)

5. Pinning information

5.1. Pinning

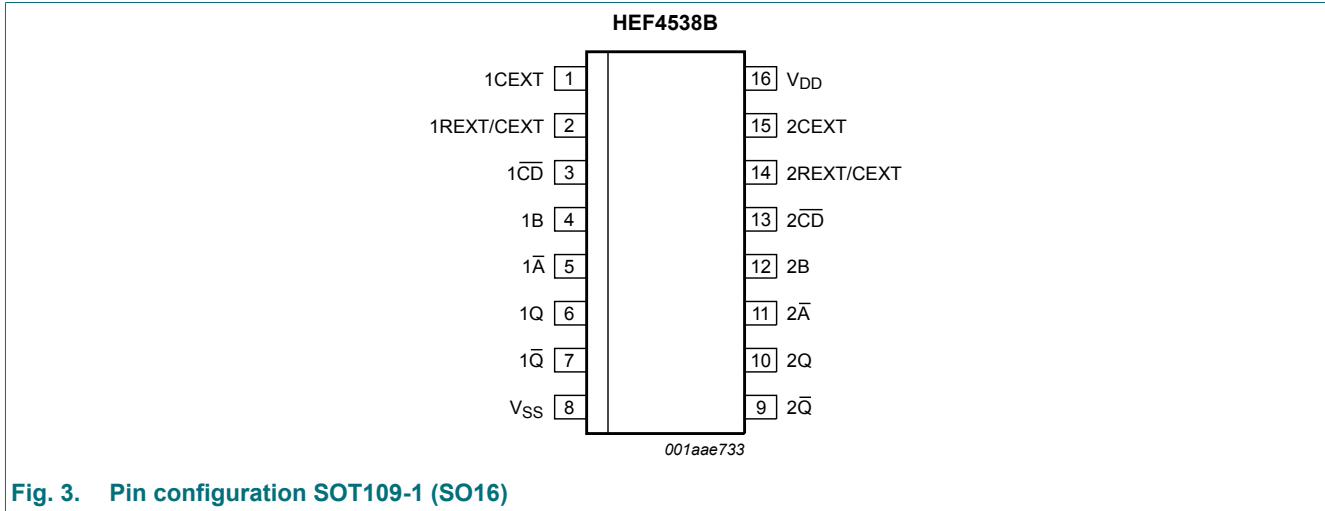

Fig. 3. Pin configuration SOT109-1 (SO16)

5.2. Pin description

Table 2. Pin description

Symbol	Pin	Description
1CEXT, 2CEXT	1, 15	external capacitor connection (always connected to ground)
1REXT/CEXT, 2REXT/CEXT	2, 14	external capacitor/resistor connection
1CD, 2CD	3, 13	direct reset input (active LOW)
1B, 2B	4, 12	input (LOW-to-HIGH triggered)
1A, 2A	5, 11	input (HIGH-to-LOW triggered)
1Q, 2Q	6, 10	output
1Q, 2Q	7, 9	complementary output (active LOW)
V _{SS}	8	ground supply voltage
V _{DD}	16	supply voltage

6. Functional description

Table 3. Function table

H = HIGH voltage level; L = LOW voltage level; X = don't care; ↑ = positive-going transition; ↓ = negative-going transition;

⎓ = one HIGH level output pulse, with the pulse width determined by C_{EXT} and R_{EXT};

⎓ = one LOW level output pulse, with the pulse width determined by C_{EXT} and R_{EXT}.

Inputs			Outputs	
nA	nB	nCD	nQ	nQ
↓	L	H	⎓	⎓
H	↑	H	⎓	⎓
X	X	L	L	H

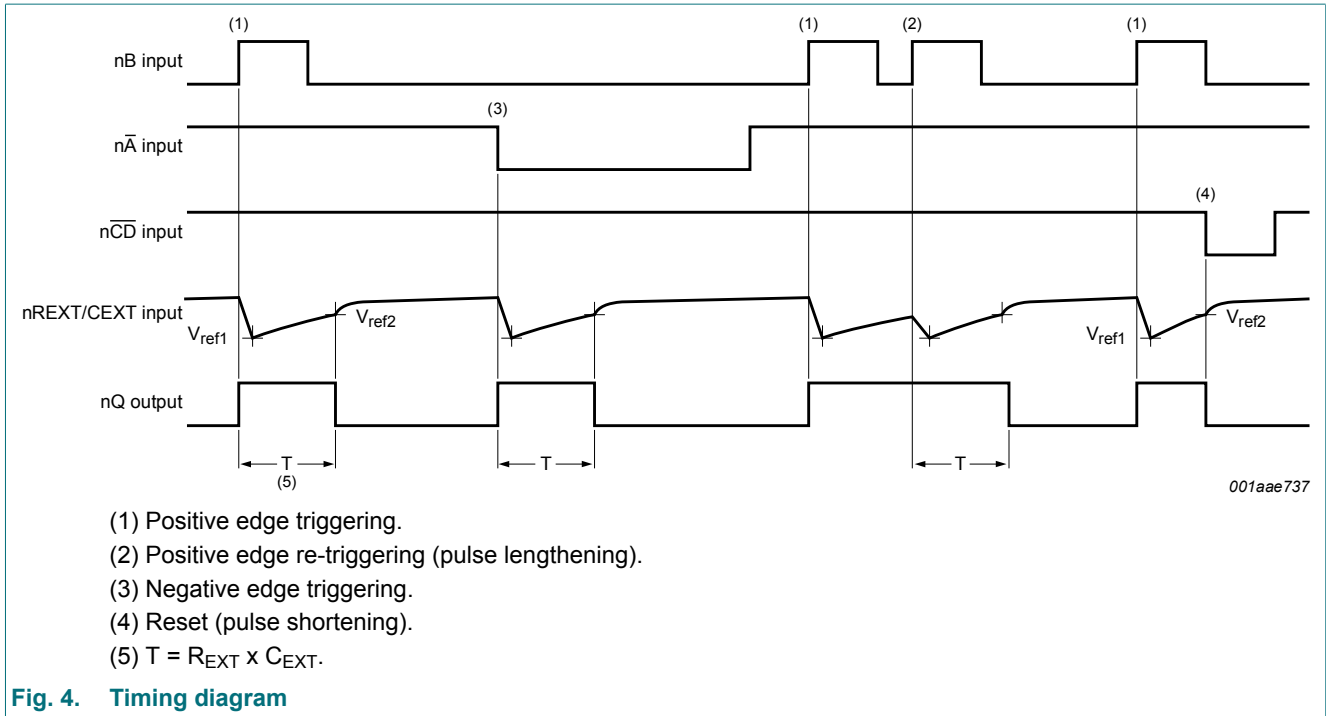

Fig. 4. Timing diagram

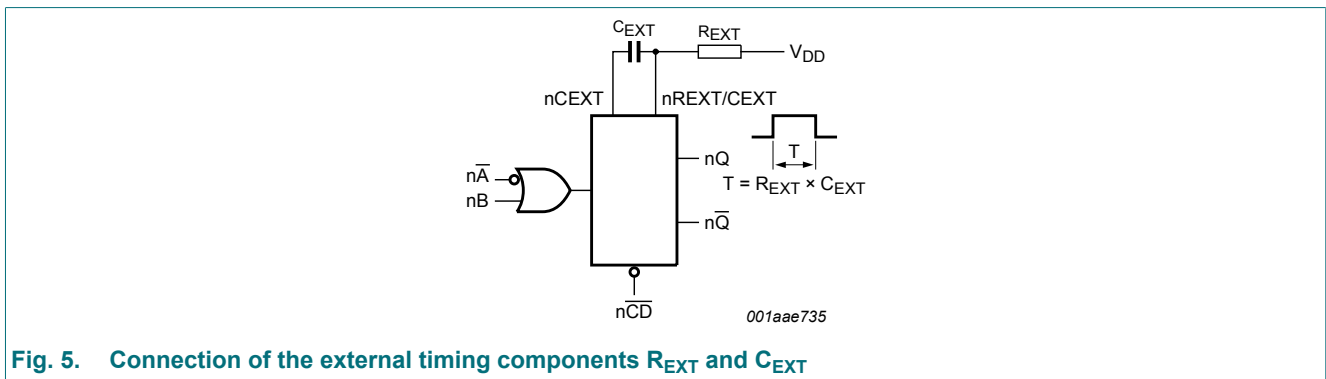

Fig. 5. Connection of the external timing components R_{EXT} and C_{EXT}

7. Limiting values

Table 4. Limiting values

In accordance with the Absolute Maximum Rating System (IEC 60134). Voltages are referenced to $V_{SS} = 0$ V (ground)

Symbol	Parameter	Conditions	Min	Max	Unit
V_{DD}	supply voltage		-0.5	+18	V
I_{IK}	input clamping current	$V_I < -0.5$ V or $V_I > V_{DD} + 0.5$ V	-	± 10	mA
V_I	input voltage		-0.5	$V_{DD} + 0.5$	V
I_{OK}	output clamping current	$V_I < -0.5$ V or $V_I > V_{DD} + 0.5$ V	-	± 10	mA
$I_{I/O}$	input/output current		-	± 10	mA
I_{DD}	supply current		-	50	mA
T_{stg}	storage temperature		-65	+150	°C
T_{amb}	ambient temperature		-40	+125	°C
P_{tot}	total power dissipation	$T_{amb} = -40$ °C to +125 °C [1]	-	500	mW
P	power dissipation	per output	-	100	mW

[1] For SO16 package: P_{tot} derates linearly with 8 mW/K above 70 °C.

8. Recommended operating conditions

Table 5. Recommended operating conditions

Symbol	Parameter	Conditions	Min	Typ	Max	Unit
V_{DD}	supply voltage		3	-	15	V
V_I	input voltage		0	-	V_{DD}	V
T_{amb}	ambient temperature	in free air	-40	-	+125	°C
$\Delta t/\Delta V$	input transition rise and fall rate	$V_{DD} = 5\text{ V}$	-	-	3.75	$\mu\text{s/V}$
		$V_{DD} = 10\text{ V}$	-	-	0.5	$\mu\text{s/V}$
		$V_{DD} = 15\text{ V}$	-	-	0.08	$\mu\text{s/V}$

9. Static characteristics

Table 6. Static characteristics

$V_{SS} = 0\text{ V}$; $V_I = V_{SS}$ or V_{DD} unless otherwise specified.

Symbol	Parameter	Conditions	V_{DD}	$T_{amb} = -40\text{ °C}$		$T_{amb} = 25\text{ °C}$		$T_{amb} = 85\text{ °C}$		$T_{amb} = 125\text{ °C}$		Unit
				Min	Max	Min	Max	Min	Max	Min	Max	
V_{IH}	HIGH-level input voltage	$ I_O < 1\ \mu\text{A}$	5 V	3.5	-	3.5	-	3.5	-	3.5	-	V
			10 V	7.0	-	7.0	-	7.0	-	7.0	-	V
			15 V	11.0	-	11.0	-	11.0	-	11.0	-	V
V_{IL}	LOW-level input voltage	$ I_O < 1\ \mu\text{A}$	5 V	-	1.5	-	1.5	-	1.5	-	1.5	V
			10 V	-	3.0	-	3.0	-	3.0	-	3.0	V
			15 V	-	4.0	-	4.0	-	4.0	-	4.0	V
V_{OH}	HIGH-level output voltage	$ I_O < 1\ \mu\text{A}$	5 V	4.95	-	4.95	-	4.95	-	4.95	-	V
			10 V	9.95	-	9.95	-	9.95	-	9.95	-	V
			15 V	14.95	-	14.95	-	14.95	-	14.95	-	V
V_{OL}	LOW-level output voltage	$ I_O < 1\ \mu\text{A}$	5 V	-	0.05	-	0.05	-	0.05	-	0.05	V
			10 V	-	0.05	-	0.05	-	0.05	-	0.05	V
			15 V	-	0.05	-	0.05	-	0.05	-	0.05	V
I_{OH}	HIGH-level output current	$V_O = 2.5\text{ V}$	5 V	-	-1.7	-	-1.4	-	-1.1	-	-1.1	mA
		$V_O = 4.6\text{ V}$	5 V	-	-0.64	-	-0.5	-	-0.36	-	-0.36	mA
		$V_O = 9.5\text{ V}$	10 V	-	-1.6	-	-1.3	-	-0.9	-	-0.9	mA
		$V_O = 13.5\text{ V}$	15 V	-	-4.2	-	-3.4	-	-2.4	-	-2.4	mA
I_{OL}	LOW-level output current	$V_O = 0.4\text{ V}$	5 V	0.64	-	0.5	-	0.36	-	0.36	-	mA
		$V_O = 0.5\text{ V}$	10 V	1.6	-	1.3	-	0.9	-	0.9	-	mA
		$V_O = 1.5\text{ V}$	15 V	4.2	-	3.4	-	2.4	-	2.4	-	mA
I_I	input leakage current	n \bar{A} , nB	15 V	-	± 0.1	-	± 0.1	-	± 1.0	-	± 1.0	μA
		nREXT/CEXT	15 V	-	± 0.3	-	± 0.1	-	± 1.0	-	± 1.0	μA
C_I	input capacitance		-	-	-	7.5	-	-	-	-	pF	

Table 7. Typical static characteristics

 $V_{SS} = 0\text{ V}$; $V_I = V_{SS}$ or V_{DD} ; $T_{amb} = +25\text{ }^\circ\text{C}$.

Symbol	Parameter	Conditions	V_{DD}	Typ	Unit
I_{DD}	supply current	active state	5 V [1]	55	μA
			10 V	150	μA
			15 V	220	μA
C_I	input capacitance	nREXT/CEXT	-	15	pF

[1] Only one monostable is switching: for the specified current during the output pulse (output nQ is HIGH).

10. Dynamic characteristics

Table 8. Dynamic characteristics

 $V_{SS} = 0\text{ V}$; $T_{amb} = 25\text{ }^\circ\text{C}$; for test circuit see Fig. 11.

Symbol	Parameter	Conditions	V_{DD}	Extrapolation formula[1]	Min	Typ	Max	Unit
t_{PHL}	HIGH to LOW propagation delay	n \bar{A} , nB to n \bar{Q} ; see Fig. 6	5 V	$193\text{ ns} + (0.55\text{ ns/pF}) C_L$	-	220	440	ns
			10 V	$74\text{ ns} + (0.23\text{ ns/pF}) C_L$	-	85	190	ns
			15 V	$52\text{ ns} + (0.16\text{ ns/pF}) C_L$	-	60	120	ns
		n $\bar{C}\bar{D}$ to nQ; see Fig. 6	5 V	$98\text{ ns} + (0.55\text{ ns/pF}) C_L$	-	125	250	ns
			10 V	$44\text{ ns} + (0.23\text{ ns/pF}) C_L$	-	55	110	ns
			15 V	$32\text{ ns} + (0.16\text{ ns/pF}) C_L$	-	40	80	ns
t_{PLH}	LOW to HIGH propagation delay	n \bar{A} , nB to nQ; see Fig. 6	5 V	$173\text{ ns} + (0.55\text{ ns/pF}) C_L$	-	200	460	ns
			10 V	$79\text{ ns} + (0.23\text{ ns/pF}) C_L$	-	90	180	ns
			15 V	$52\text{ ns} + (0.16\text{ ns/pF}) C_L$	-	60	120	ns
		n $\bar{C}\bar{D}$ to n \bar{Q} ; see Fig. 6	5 V	$98\text{ ns} + (0.55\text{ ns/pF}) C_L$	-	125	250	ns
			10 V	$44\text{ ns} + (0.23\text{ ns/pF}) C_L$	-	55	110	ns
			15 V	$32\text{ ns} + (0.16\text{ ns/pF}) C_L$	-	40	80	ns
t_t	transition time	see Fig. 6	5 V [2]	$10\text{ ns} + (1.00\text{ ns/pF}) C_L$	-	60	120	ns
			10 V	$9\text{ ns} + (0.42\text{ ns/pF}) C_L$	-	30	60	ns
			15 V	$6\text{ ns} + (0.28\text{ ns/pF}) C_L$	-	20	40	ns
t_{rec}	recovery time	n $\bar{C}\bar{D}$ to n \bar{A} , nB; see Fig. 7	5 V		-	20	40	ns
			10 V		-	10	20	ns
			15 V		-	5	10	ns
t_{rtrig}	retrigger time	nQ, n \bar{Q} to n \bar{A} , nB; see Fig. 7	5 V		0	-	-	ns
			10 V		0	-	-	ns
			15 V		0	-	-	ns

Dual precision monostable multivibrator

Symbol	Parameter	Conditions	V _{DD}	Extrapolation formula[1]	Min	Typ	Max	Unit	
t _w	pulse width	n \bar{A} LOW; minimum width; see Fig. 7	5 V		90	45	-	ns	
			10 V		30	15	-	ns	
			15 V		24	12	-	ns	
		nB HIGH; minimum width; see Fig. 7	5 V		50	25	-	ns	
			10 V		24	12	-	ns	
			15 V		20	10	-	ns	
		n $\bar{C}\bar{D}$ LOW; minimum width; see Fig. 7	5 V		55	25	-	ns	
			10 V		25	12	-	ns	
			15 V		20	10	-	ns	
		nQ or n \bar{Q} ; R _{EXT} = 100 k Ω ; C _{EXT} = 2.0 nF; see Fig. 7	5 V		218	230	242	μ s	
			10 V		213	224	235	μ s	
			15 V		211	223	234	μ s	
		nQ or n \bar{Q} ; R _{EXT} = 100 k Ω ; C _{EXT} = 0.1 μ F; see Fig. 7	5 V		10.3	10.8	11.3	ms	
			10 V		10.2	10.7	11.2	ms	
			15 V		10.1	10.6	11.1	ms	
nQ or n \bar{Q} ; R _{EXT} = 100 k Ω ; C _{EXT} = 10 μ F; see Fig. 7	5 V		1.01	1.09	1.11	s			
	10 V		0.99	1.04	1.09	s			
	15 V		0.99	1.04	1.09	s			
Δt_w	pulse width variation	nQ or n \bar{Q} variation over temperature range; see Fig. 8	5 V		-	± 0.2	-	%	
			10 V		-	± 0.2	-	%	
			15 V		-	± 0.2	-	%	
		nQ or n \bar{Q} variation over V _{DD} voltage range 5 V to 15 V; see Fig. 9			-	± 1.5	-	%	
			nQ or n \bar{Q} variation between monostables in the same device; R _{EXT} = 100 k Ω ; C _{EXT} = 2 nF to 10 μ F	5 V		-	± 1	-	%
				10 V		-	± 1	-	%
15 V		-		± 1	-	%			
R _{EXT}	external timing resistor				5	-	[3]	k Ω	
C _{EXT}	external timing capacitor				2000	-	no limits	pF	

[1] The typical values of the propagation delay and transition times are calculated from the extrapolation formulas shown (C_L in pF).

[2] t_i is the same as t_{THL} and t_{TLH}.

[3] The maximum permissible resistance R_{EXT}, which holds the specified accuracy of t_w (nQ, n \bar{Q} output), depends on the leakage current of the capacitor C_{EXT} and the leakage current of the HEF4538B.

10.1. Waveforms and test circuit

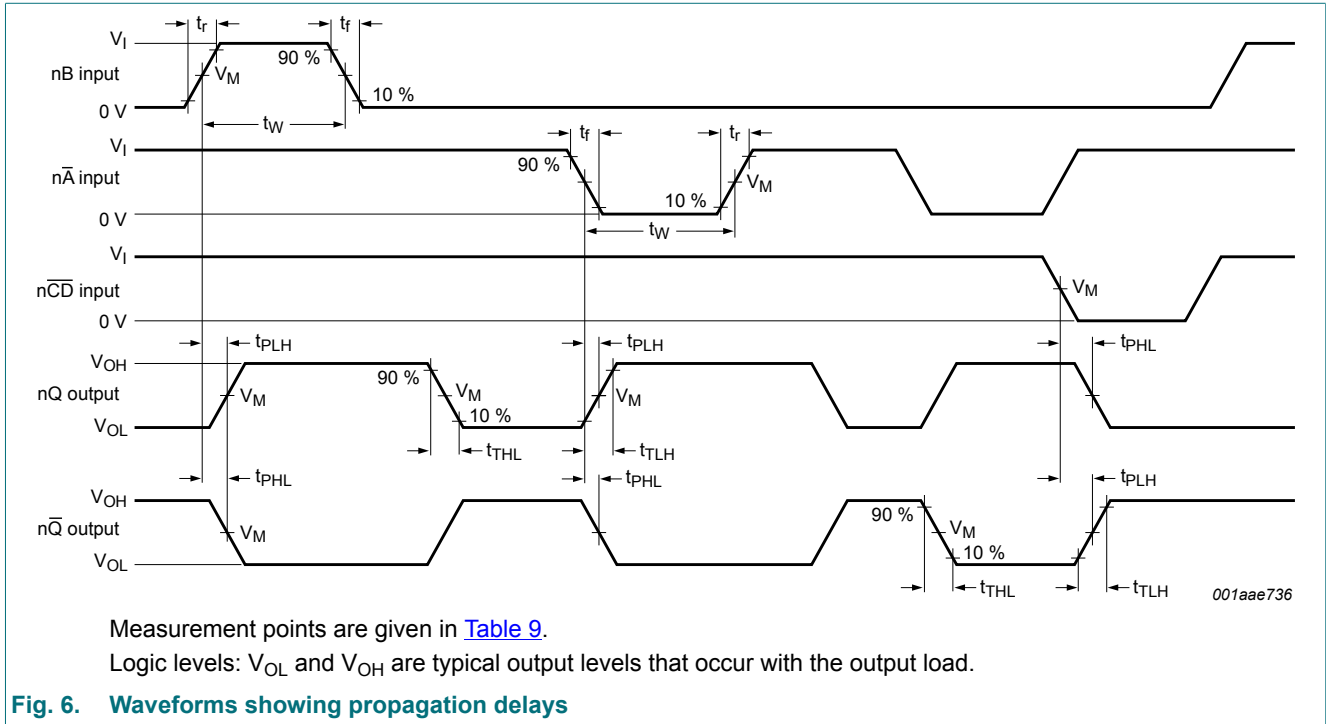
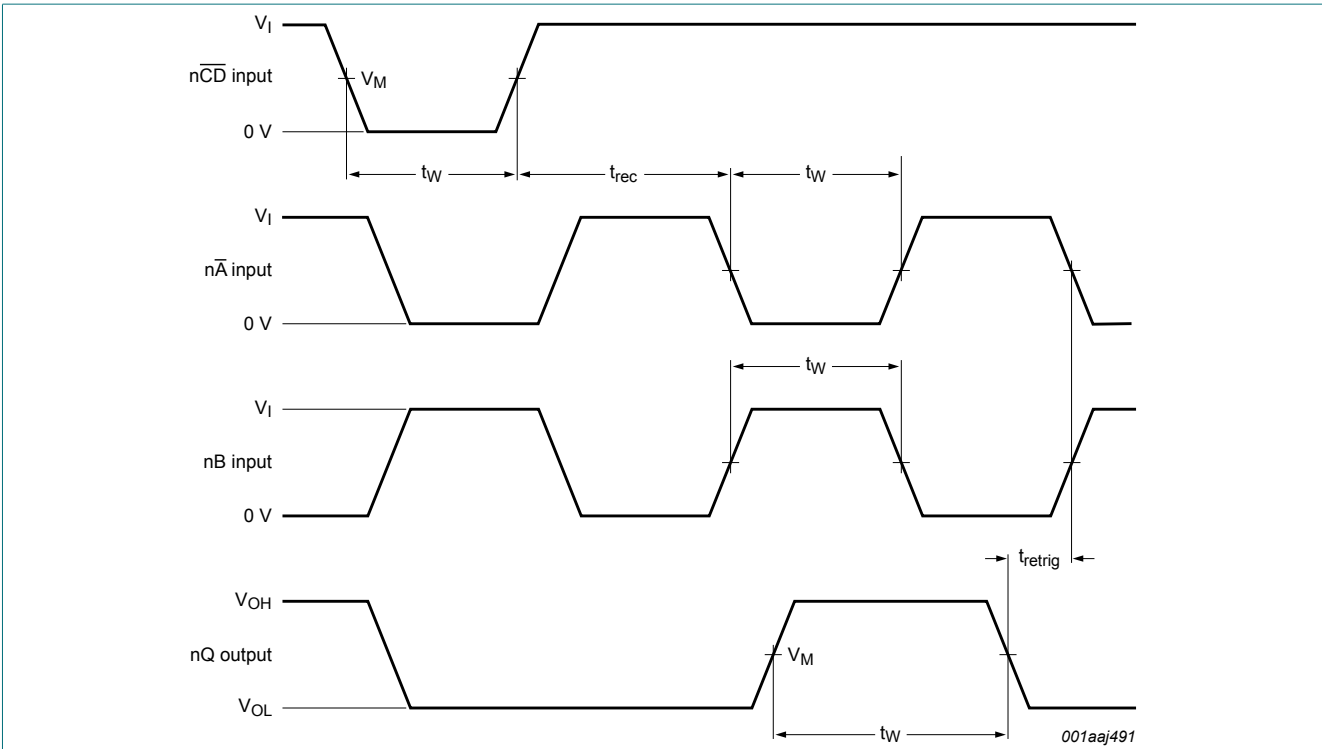

Table 9. Measurement points

Supply voltage	Input	Output
V_{DD}	V_M	V_M
5 V to 15 V	$0.5V_{DD}$	$0.5V_{DD}$



Measurement points are given in [Table 9](#).

Recovery times are shown as positive values but may be specified as negative values.

Logic levels: V_{OL} and V_{OH} are typical output levels that occur with the output load.

Fig. 7. Waveforms showing minimum $n\overline{CD}$, $n\overline{A}$, nB , and nQ pulse widths, recovery and retrigger times

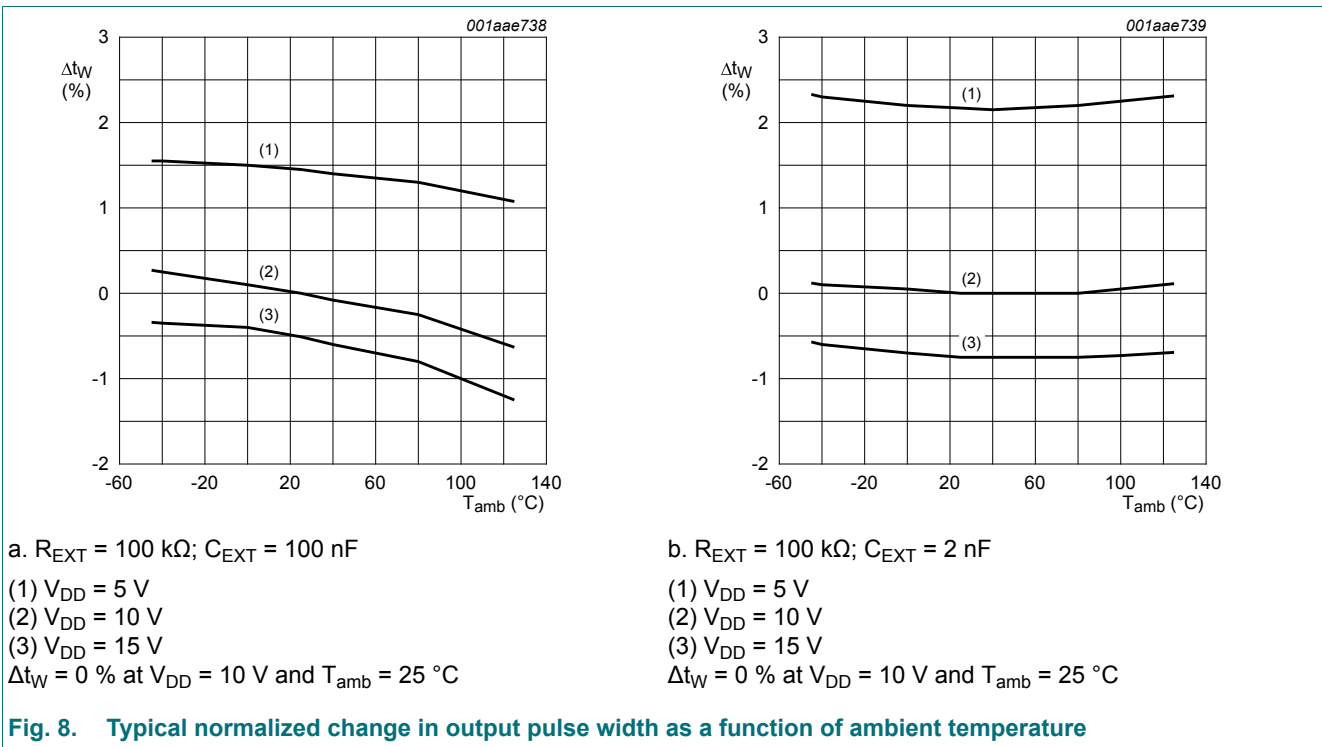

a. $R_{EXT} = 100$ k Ω ; $C_{EXT} = 100$ nF

(1) $V_{DD} = 5$ V

(2) $V_{DD} = 10$ V

(3) $V_{DD} = 15$ V

$\Delta t_W = 0$ % at $V_{DD} = 10$ V and $T_{amb} = 25$ °C

b. $R_{EXT} = 100$ k Ω ; $C_{EXT} = 2$ nF

(1) $V_{DD} = 5$ V

(2) $V_{DD} = 10$ V

(3) $V_{DD} = 15$ V

$\Delta t_W = 0$ % at $V_{DD} = 10$ V and $T_{amb} = 25$ °C

Fig. 8. Typical normalized change in output pulse width as a function of ambient temperature

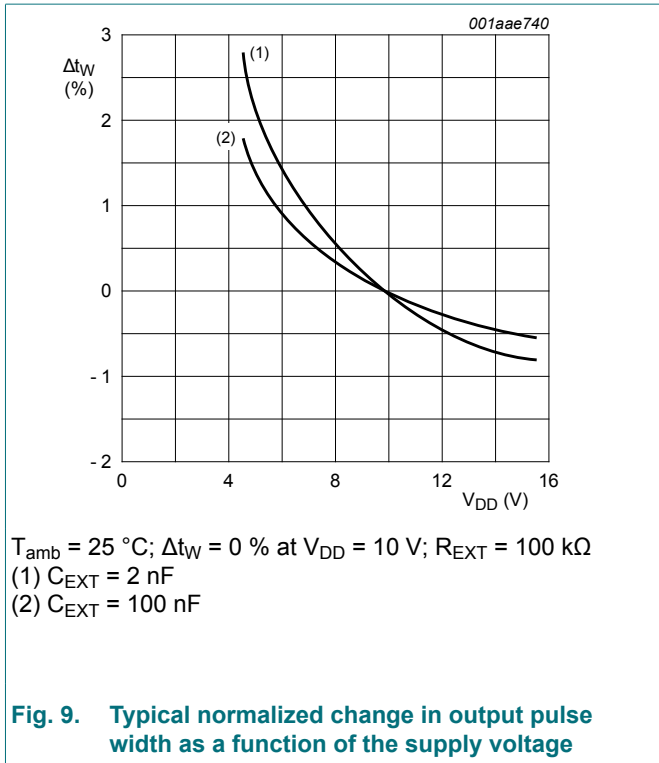

Fig. 9. Typical normalized change in output pulse width as a function of the supply voltage

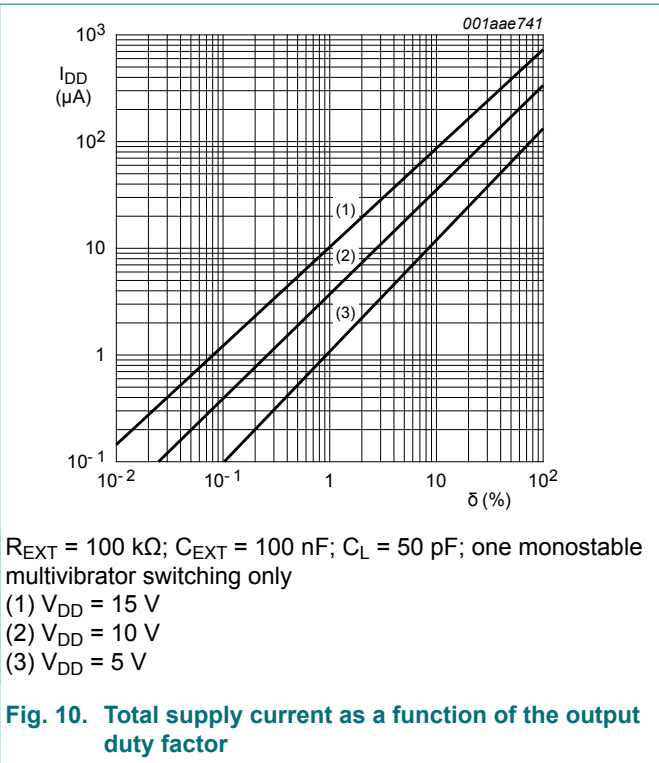

Fig. 10. Total supply current as a function of the output duty factor

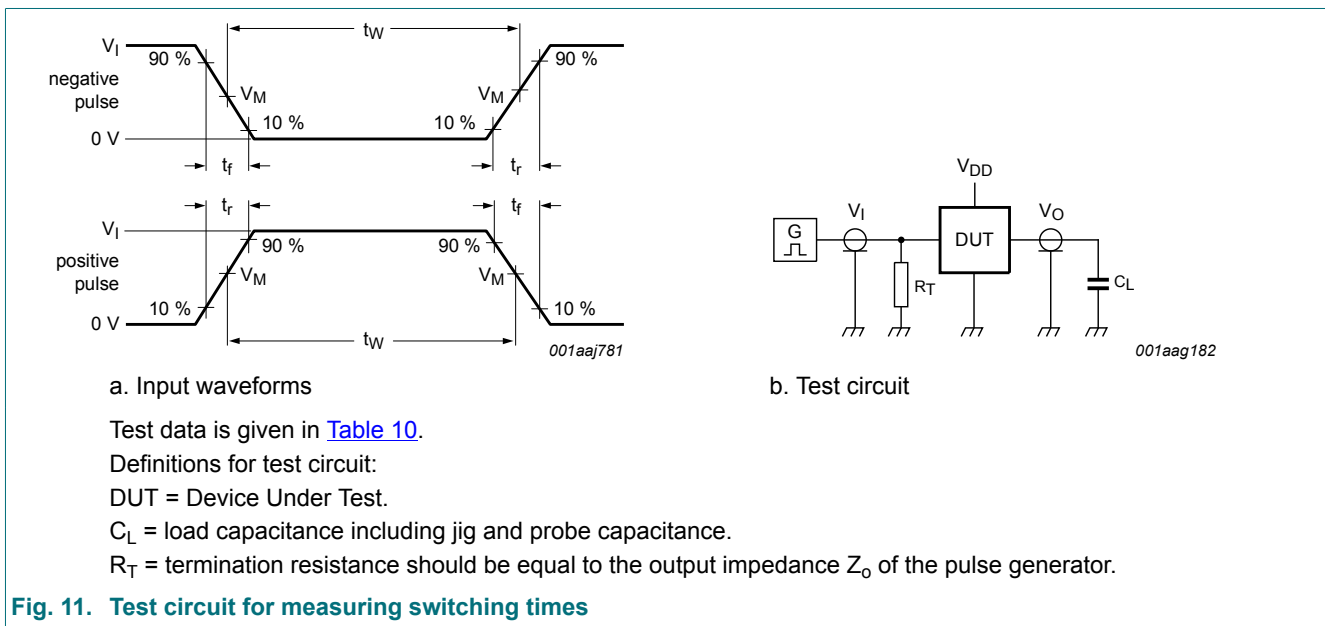

Fig. 11. Test circuit for measuring switching times

Table 10. Test data

Supply voltage	Input	Load
V_{DD}	V_I	C_L
5 V to 15 V	V_{SS} or V_{DD}	50 pF

11. Package outline

SO16: plastic small outline package; 16 leads; body width 3.9 mm

SOT109-1

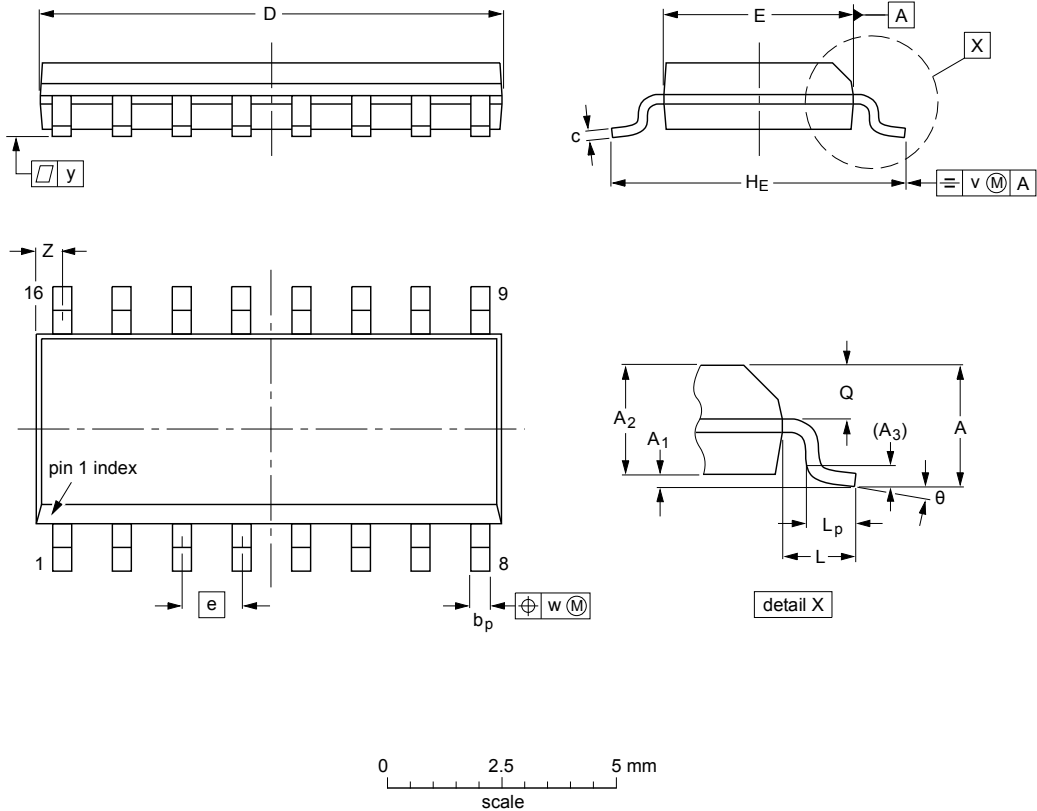

DIMENSIONS (inch dimensions are derived from the original mm dimensions)

UNIT	A max.	A ₁	A ₂	A ₃	b _p	c	D ⁽¹⁾	E ⁽¹⁾	e	H _E	L	L _p	Q	v	w	y	Z ⁽¹⁾	θ
mm	1.75	0.25 0.10	1.45 1.25	0.25	0.49 0.36	0.25 0.19	10.0 9.8	4.0 3.8	1.27	6.2 5.8	1.05	1.0 0.4	0.7 0.6	0.25	0.25	0.1	0.7 0.3	8° 0°
inches	0.069	0.010 0.004	0.057 0.049	0.01	0.019 0.014	0.0100 0.0075	0.39 0.38	0.16 0.15	0.05	0.244 0.228	0.041	0.039 0.016	0.028 0.020	0.01	0.01	0.004	0.028 0.012	

Note

1. Plastic or metal protrusions of 0.15 mm (0.006 inch) maximum per side are not included.

OUTLINE VERSION	REFERENCES				EUROPEAN PROJECTION	ISSUE DATE
	IEC	JEDEC	JEITA			
SOT109-1	076E07	MS-012				99-12-27 03-02-19

Fig. 12. Package outline SOT109-1 (SO16)

12. Abbreviations

Table 11. Abbreviations

Acronym	Description
CMOS	Complementary Metal-Oxide Semiconductor
DUT	Device Under Test

13. Revision history

Table 12. Revision history

Document ID	Release date	Data sheet status	Change notice	Supersedes
HEF4538B v.11	20181019	Product data sheet	-	HEF4538B v.10
Modifications:	<ul style="list-style-type: none"> The format of this data sheet has been redesigned to comply with the identity guidelines of Nexperia. Legal texts have been adapted to the new company name where appropriate. 			
HEF4538B v.10	20160401	Product data sheet	-	HEF4538B v.9
Modifications:	<ul style="list-style-type: none"> Type number HEF4538BP (SOT38-4) removed. 			
HEF4538B v.9	20131210	Product data sheet	-	HEF4538B v.8
Modifications:	<ul style="list-style-type: none"> Fig. 8 and Fig. 9 updated to show output pulse width over full temperature range. 			
HEF4538B v.8	20111116	Product data sheet	-	HEF4538B v.7
HEF4538B v.7	20110217	Product data sheet	-	HEF4538B v.6
HEF4538B v.6	20091102	Product data sheet	-	HEF4538B v.5
HEF4538B v.5	20090304	Product data sheet	-	HEF4538B v.4
HEF4538B v.4	20090206	Product data sheet	-	HEF4538B_CNV v.3
HEF4538B_CNV v.3	19950101	Product specification	-	HEF4538B_CNV v.2
HEF4538B_CNV v.2	19950101	Product specification	-	-

14. Legal information

Data sheet status

Document status [1][2]	Product status [3]	Definition
Objective [short] data sheet	Development	This document contains data from the objective specification for product development.
Preliminary [short] data sheet	Qualification	This document contains data from the preliminary specification.
Product [short] data sheet	Production	This document contains the product specification.

- [1] Please consult the most recently issued document before initiating or completing a design.
- [2] The term 'short data sheet' is explained in section "Definitions".
- [3] The product status of device(s) described in this document may have changed since this document was published and may differ in case of multiple devices. The latest product status information is available on the internet at <https://www.nexperia.com>.

Definitions

Draft — The document is a draft version only. The content is still under internal review and subject to formal approval, which may result in modifications or additions. Nexperia does not give any representations or warranties as to the accuracy or completeness of information included herein and shall have no liability for the consequences of use of such information.

Short data sheet — A short data sheet is an extract from a full data sheet with the same product type number(s) and title. A short data sheet is intended for quick reference only and should not be relied upon to contain detailed and full information. For detailed and full information see the relevant full data sheet, which is available on request via the local Nexperia sales office. In case of any inconsistency or conflict with the short data sheet, the full data sheet shall prevail.

Product specification — The information and data provided in a Product data sheet shall define the specification of the product as agreed between Nexperia and its customer, unless Nexperia and customer have explicitly agreed otherwise in writing. In no event however, shall an agreement be valid in which the Nexperia product is deemed to offer functions and qualities beyond those described in the Product data sheet.

Disclaimers

Limited warranty and liability — Information in this document is believed to be accurate and reliable. However, Nexperia does not give any representations or warranties, expressed or implied, as to the accuracy or completeness of such information and shall have no liability for the consequences of use of such information. Nexperia takes no responsibility for the content in this document if provided by an information source outside of Nexperia.

In no event shall Nexperia be liable for any indirect, incidental, punitive, special or consequential damages (including - without limitation - lost profits, lost savings, business interruption, costs related to the removal or replacement of any products or rework charges) whether or not such damages are based on tort (including negligence), warranty, breach of contract or any other legal theory.

Notwithstanding any damages that customer might incur for any reason whatsoever, Nexperia's aggregate and cumulative liability towards customer for the products described herein shall be limited in accordance with the Terms and conditions of commercial sale of Nexperia.

Right to make changes — Nexperia reserves the right to make changes to information published in this document, including without limitation specifications and product descriptions, at any time and without notice. This document supersedes and replaces all information supplied prior to the publication hereof.

Suitability for use — Nexperia products are not designed, authorized or warranted to be suitable for use in life support, life-critical or safety-critical systems or equipment, nor in applications where failure or malfunction of an Nexperia product can reasonably be expected to result in personal

injury, death or severe property or environmental damage. Nexperia and its suppliers accept no liability for inclusion and/or use of Nexperia products in such equipment or applications and therefore such inclusion and/or use is at the customer's own risk.

Quick reference data — The Quick reference data is an extract of the product data given in the Limiting values and Characteristics sections of this document, and as such is not complete, exhaustive or legally binding.

Applications — Applications that are described herein for any of these products are for illustrative purposes only. Nexperia makes no representation or warranty that such applications will be suitable for the specified use without further testing or modification.

Customers are responsible for the design and operation of their applications and products using Nexperia products, and Nexperia accepts no liability for any assistance with applications or customer product design. It is customer's sole responsibility to determine whether the Nexperia product is suitable and fit for the customer's applications and products planned, as well as for the planned application and use of customer's third party customer(s). Customers should provide appropriate design and operating safeguards to minimize the risks associated with their applications and products.

Nexperia does not accept any liability related to any default, damage, costs or problem which is based on any weakness or default in the customer's applications or products, or the application or use by customer's third party customer(s). Customer is responsible for doing all necessary testing for the customer's applications and products using Nexperia products in order to avoid a default of the applications and the products or of the application or use by customer's third party customer(s). Nexperia does not accept any liability in this respect.

Limiting values — Stress above one or more limiting values (as defined in the Absolute Maximum Ratings System of IEC 60134) will cause permanent damage to the device. Limiting values are stress ratings only and (proper) operation of the device at these or any other conditions above those given in the Recommended operating conditions section (if present) or the Characteristics sections of this document is not warranted. Constant or repeated exposure to limiting values will permanently and irreversibly affect the quality and reliability of the device.

Terms and conditions of commercial sale — Nexperia products are sold subject to the general terms and conditions of commercial sale, as published at <http://www.nexperia.com/profile/terms>, unless otherwise agreed in a valid written individual agreement. In case an individual agreement is concluded only the terms and conditions of the respective agreement shall apply. Nexperia hereby expressly objects to applying the customer's general terms and conditions with regard to the purchase of Nexperia products by customer.

No offer to sell or license — Nothing in this document may be interpreted or construed as an offer to sell products that is open for acceptance or the grant, conveyance or implication of any license under any copyrights, patents or other industrial or intellectual property rights.

Export control — This document as well as the item(s) described herein may be subject to export control regulations. Export might require a prior authorization from competent authorities.

Non-automotive qualified products — Unless this data sheet expressly states that this specific Nexperia product is automotive qualified, the product is not suitable for automotive use. It is neither qualified nor tested in accordance with automotive testing or application requirements. Nexperia accepts no liability for inclusion and/or use of non-automotive qualified products in automotive equipment or applications.

In the event that customer uses the product for design-in and use in automotive applications to automotive specifications and standards, customer (a) shall use the product without Nexperia's warranty of the product for such automotive applications, use and specifications, and (b) whenever customer uses the product for automotive applications beyond Nexperia's specifications such use shall be solely at customer's own risk, and (c) customer fully indemnifies Nexperia for any liability, damages or failed product claims resulting from customer design and use of the product for automotive applications beyond Nexperia's standard warranty and Nexperia's product specifications.

Translations — A non-English (translated) version of a document is for reference only. The English version shall prevail in case of any discrepancy between the translated and English versions.

Trademarks

Notice: All referenced brands, product names, service names and trademarks are the property of their respective owners.

Contents

1. General description	1
2. Features and benefits	1
3. Ordering information	1
4. Functional diagram	2
5. Pinning information	3
5.1. Pinning.....	3
5.2. Pin description.....	3
6. Functional description	3
7. Limiting values	4
8. Recommended operating conditions	5
9. Static characteristics	5
10. Dynamic characteristics	6
10.1. Waveforms and test circuit.....	8
11. Package outline	11
12. Abbreviations	12
13. Revision history	12
14. Legal information	13

© Nexperia B.V. 2018. All rights reserved

For more information, please visit: <http://www.nexperia.com>
For sales office addresses, please send an email to: salesaddresses@nexperia.com
Date of release: 19 October 2018





Looking for pricing, stock, or lifecycle information?

Click below to explore more details on WIN SOURCE:

 [View HEF4538BP,652 on WIN SOURCE](#)

 [NXP / Nexperia Information](#)

Optimize Your Supply Chain with WIN SOURCE Solutions

-  Global Sourcing Solution
-  Obsolete Management
-  Cost Control Management
-  Shortage Management
-  Alternative Solution
-  Excess Inventory Management