



Is Now Part of



ON Semiconductor®

To learn more about ON Semiconductor, please visit our website at
www.onsemi.com

Please note: As part of the Fairchild Semiconductor integration, some of the Fairchild orderable part numbers will need to change in order to meet ON Semiconductor's system requirements. Since the ON Semiconductor product management systems do not have the ability to manage part nomenclature that utilizes an underscore (_), the underscore (_) in the Fairchild part numbers will be changed to a dash (-). This document may contain device numbers with an underscore (_). Please check the ON Semiconductor website to verify the updated device numbers. The most current and up-to-date ordering information can be found at www.onsemi.com. Please email any questions regarding the system integration to Fairchild_questions@onsemi.com.

ON Semiconductor and the ON Semiconductor logo are trademarks of Semiconductor Components Industries, LLC dba ON Semiconductor or its subsidiaries in the United States and/or other countries. ON Semiconductor owns the rights to a number of patents, trademarks, copyrights, trade secrets, and other intellectual property. A listing of ON Semiconductor's product/patent coverage may be accessed at www.onsemi.com/site/pdf/Patent-Marking.pdf. ON Semiconductor reserves the right to make changes without further notice to any products herein. ON Semiconductor makes no warranty, representation or guarantee regarding the suitability of its products for any particular purpose, nor does ON Semiconductor assume any liability arising out of the application or use of any product or circuit, and specifically disclaims any and all liability, including without limitation special, consequential or incidental damages. Buyer is responsible for its products and applications using ON Semiconductor products, including compliance with all laws, regulations and safety requirements or standards, regardless of any support or applications information provided by ON Semiconductor. "Typical" parameters which may be provided in ON Semiconductor data sheets and/or specifications can and do vary in different applications and actual performance may vary over time. All operating parameters, including "Typicals" must be validated for each customer application by customer's technical experts. ON Semiconductor does not convey any license under its patent rights nor the rights of others. ON Semiconductor products are not designed, intended, or authorized for use as a critical component in life support systems or any FDA Class 3 medical devices or medical devices with a same or similar classification in a foreign jurisdiction or any devices intended for implantation in the human body. Should Buyer purchase or use ON Semiconductor products for any such unintended or unauthorized application, Buyer shall indemnify and hold ON Semiconductor and its officers, employees, subsidiaries, affiliates, and distributors harmless against all claims, costs, damages, and expenses, and reasonable attorney fees arising out of, directly or indirectly, any claim of personal injury or death associated with such unintended or unauthorized use, even if such claim alleges that ON Semiconductor was negligent regarding the design or manufacture of the part. ON Semiconductor is an Equal Opportunity/Affirmative Action Employer. This literature is subject to all applicable copyright laws and is not for resale in any manner.



FAN6961

Boundary Mode PFC Controller

Features

- Boundary Mode PFC Controller
- Low Input Current THD
- Controlled On-Time PWM
- Zero-Current Detection
- Cycle-by-Cycle Current Limiting
- Leading-Edge Blanking instead of RC Filtering
- Low Startup Current: 10 μ A Typical
- Low Operating Current: 4.5 mA Typical
- Feedback Open-Loop Protection
- Programmable Maximum On-Time (MOT)
- Output Over-Voltage Clamping Protection
- Clamped Gate Output Voltage 16.5 V

Description

The FAN6961 is an 8-pin, boundary-mode, PFC controller IC intended for controlling PFC pre-regulators. The FAN6961 provides a controlled on-time to regulate the output DC voltage and achieve natural power factor correction. The maximum on-time of the external switch is programmable to ensure safe operation during AC brownouts. An innovative multi-vector error amplifier is built in to provide rapid transient response and precise output voltage clamping. A built-in circuit disables the controller if the output feedback loop is opened. The startup current is lower than 20 μ A and the operating current has been reduced to under 6 mA. The supply voltage can be up to 25 V, maximizing application flexibility.

Applications

- Electric Lamp Ballasts
- AC-DC Switching Mode Power Converter
- Open Frame Power Supplies and Power Adapters
- Flyback Power Converters with ZCS / ZVS

Ordering Information

| Part Number | Operating Temperature Range | Package | Packing Method |
|-------------|-----------------------------|---|----------------|
| FAN6961SZ | -40°C to +125°C | 8-Pin, Small Outline Package (SOP) ⁽¹⁾ | Tape & Reel |
| FAN6961DZ | -40°C to +125°C | 8-Pin, Dual In-line Package (DIP) | Tube |
| FAN6961SY | -40°C to +125°C | 8-Pin, Small Outline Package (SOP) ⁽¹⁾ | Tape & Reel |

Note:

1. SZ & SY are for Eco status, please refer to <https://www.fairchildsemi.com/products/power-management/power-factor-correction/critical-bounary-conduction-mode-crcm/FAN6961.html>.

Application Diagram

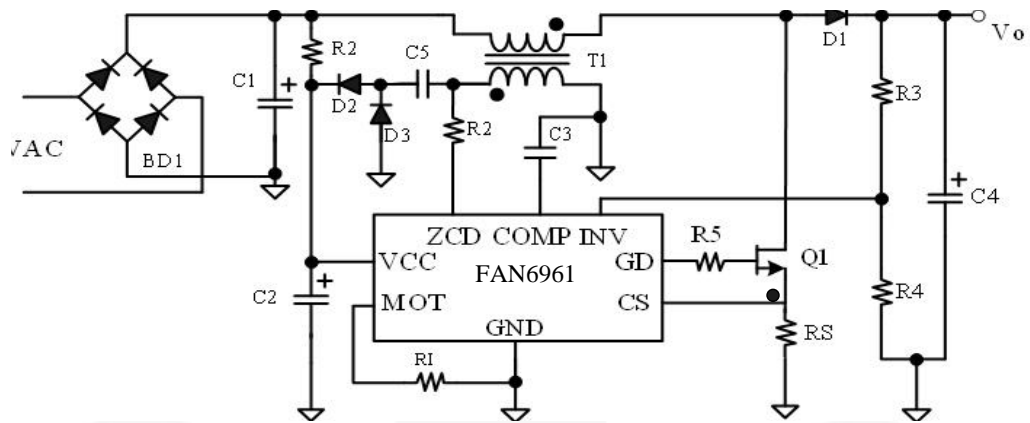

Figure 1. Typical Application

Block Diagram

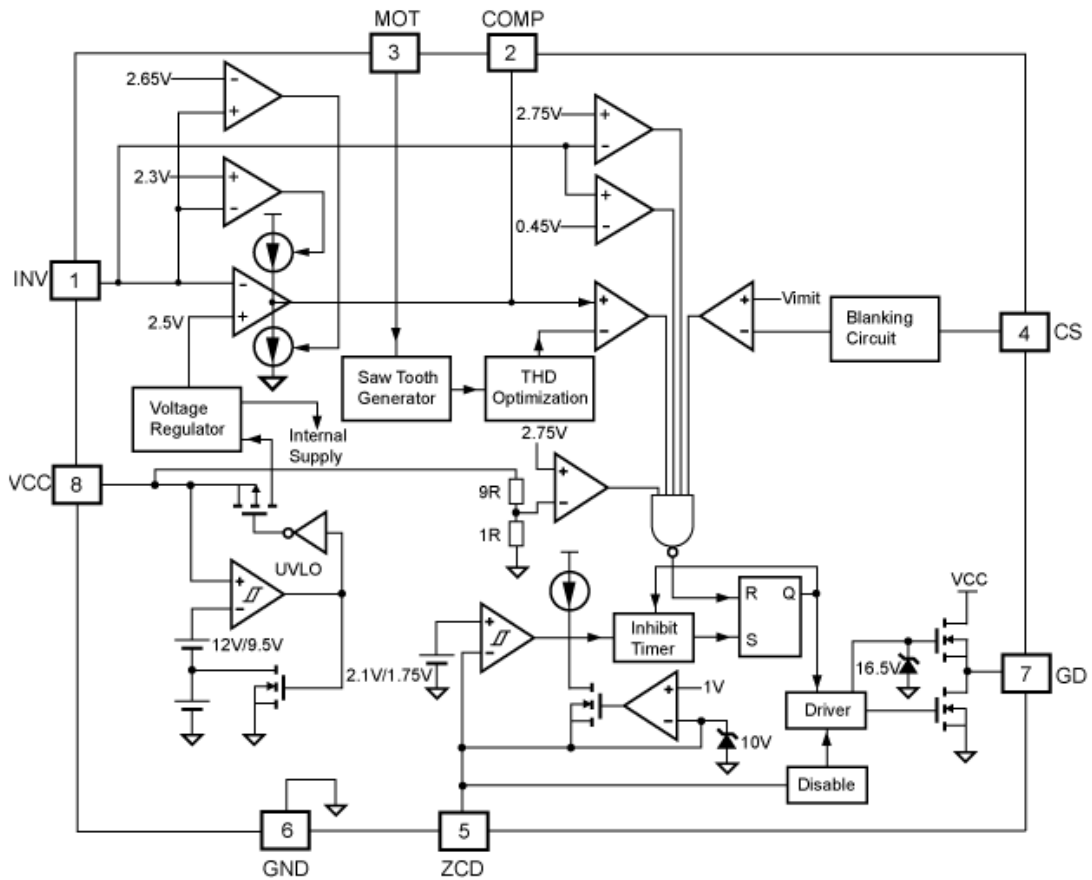
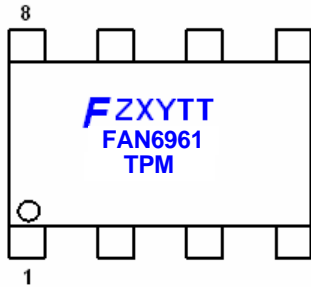

Figure 2. Function Block Diagram

Marking Information



F- Fairchild Logo
Z- Plant Code
X- Year Code
Y- Week Code
TT: Die Run Code
T: Package Type (S=SOP, D=DIP)
P: Z: Pb Free **Y**: Green Compound
M: Manufacture Flow Code

Figure 3. Marking Information

Pin Configuration

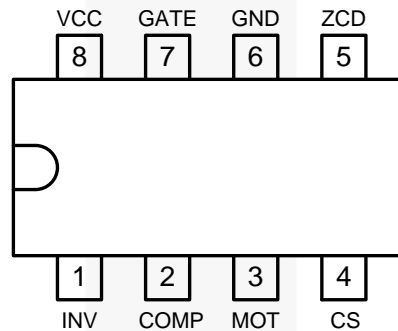

Figure 4. DIP and SOP Pin Configuration (Top View)

Pin Definitions

| Pin # | Name | Description |
|-------|------|---|
| 1 | INV | Inverting Input of the Error Amplifier. INV is connected to the converter output via a resistive divider. This pin is also used for over-voltage clamping and open-loop feedback protection. |
| 2 | COMP | Output of the Error Amplifier. To create a precise clamping protection, a compensation network between this pin and GND is suggested. |
| 3 | MOT | Maximum On Time. A resistor from MOT to GND is used to determine the maximum on-time of the external power MOSFET. The maximum output power of the converter is a function of the maximum on time. |
| 4 | CS | Current Sense. Input to the over-current protection comparator. When the sensed voltage across the sense resistor reaches the internal threshold (0.8 V), the switch is turned off to activate cycle-by-cycle current limiting. |
| 5 | ZCD | Zero Current Detection. This pin is connected to an auxiliary winding via a resistor to detect the zero crossing of the switch current. When the zero crossing is detected, a new switching cycle is started. If it is connected to GND, the device is disabled. |
| 6 | GND | Ground. The power ground and signal ground. Placing a 0.1 μ F decoupling capacitor between VCC and GND is recommended. |
| 7 | GATE | Driver Output. Totem-pole driver output to drive the external power MOSFET. The clamped gate output voltage is 16.5 V. |
| 8 | VCC | Power Supply. Driver and control circuit supply voltage. |

Absolute Maximum Ratings

Stresses exceeding the absolute maximum ratings may damage the device. The device may not function or be operable above the recommended operating conditions and stressing the parts to these levels is not recommended. In addition, extended exposure to stresses above the recommended operating conditions may affect device reliability. The absolute maximum ratings are stress ratings only. All voltage values, except differential voltage, are given with respect to GND pin.

| Symbol | Parameter | Min. | Max. | Unit |
|-------------------|---|------|------|------|
| V _{VCC} | DC Supply Voltage | | 30 | V |
| V _{HIGH} | Gate Driver | -0.3 | 30.0 | V |
| V _{LOW} | Others (INV, COMP, MOT, CS) | -0.3 | 7.0 | V |
| V _{ZCD} | Input Voltage to ZCD Pin | -0.3 | 12.0 | V |
| P _D | Power Dissipation | SOP | 400 | mW |
| | | DIP | 800 | |
| T _J | Operating Junction Temperature | -40 | +125 | °C |
| θ _{JA} | Thermal Resistance (Junction-to-Air) | SOP | 150 | °C/W |
| | | DIP | 113 | |
| T _{STG} | Storage Temperature Range | -65 | +150 | °C |
| T _L | Lead Temperature (Wave Soldering or IR, 10 Seconds) | SOP | +230 | °C |
| | | DIP | +260 | |
| ESD | Human Body Model: JESD22-A114 | | 2.5 | KV |
| | Machine Model: JESD22-A115 | | 200 | V |

Recommended Operating Conditions

The Recommended Operating Conditions table defines the conditions for actual device operation. Recommended operating conditions are specified to ensure optimal performance to the datasheet specifications. Fairchild does not recommend exceeding them or designing to Absolute Maximum Ratings.

| Symbol | Parameter | Min. | Typ. | Max. | Unit |
|----------------|-------------------------------|------|------|------|------|
| T _A | Operating Ambient Temperature | -40 | | +125 | °C |

Electrical Characteristics

Unless otherwise noted, $V_{CC}=15\text{ V}$ and $T_J=-40^{\circ}\text{C}$ to 125°C . Current is defined as positive into the device and negative out of the device.

| Symbol | Parameter | Conditions | Min. | Typ. | Max. | Units |
|--------------------------------|---|--|-------|-------|-------|-----------------|
| V_{CC} Section | | | | | | |
| V_{CC-OP} | Continuous Operation Voltage | | | | 24.5 | V |
| V_{CC-ON} | Turn-On Threshold Voltage | | 11.5 | 12.5 | 13.5 | V |
| V_{CC-OFF} | Turn-Off Threshold Voltage | | 8.5 | 9.5 | 10.5 | V |
| I_{CC-ST} | Startup Current | $V_{CC}=V_{CC-ON} - 0.16\text{ V}$ | | 10 | 20 | μA |
| I_{CC-OP} | Operating Supply Current | $V_{CC}=12\text{ V}$, $V_{CS}=0\text{ V}$, $C_L=3\text{ nF}$, $f_{SW}=60\text{ KHz}$ | | 4.5 | 6 | mA |
| V_{CC-OVP} | V_{DD} Over-Voltage Protection Level | | 26.8 | 27.8 | 28.8 | V |
| $t_{D-VCCOVP}$ | V_{DD} Over-Voltage Protection Debounce | | | 30 | | μs |
| Error Amplifier Section | | | | | | |
| V_{REF} | Reference Voltage | | 2.475 | 2.500 | 2.525 | V |
| G_m | Transconductance | | | 125 | | μmho |
| V_{INVH} | Clamp High Feedback Voltage | | | 2.65 | 2.70 | V |
| V_{INVL} | Clamp Low Feedback Voltage | | 2.25 | 2.30 | | V |
| $V_{OUT-HIGH}$ | Output High Voltage | | 4.8 | | | V |
| V_{OZ} | Zero Duty Cycle Output Voltage | | 1.15 | 1.25 | 1.35 | V |
| $V_{INV-OVP}$ | Over Voltage Protection for INV Input | | 2.70 | 2.75 | 2.80 | V |
| $V_{INV-UVP}$ | Under Voltage Protection for INV Input | | 0.40 | 0.45 | 0.50 | V |
| I_{COMP} | Source Current | $V_{INV}=2.35\text{ V}$, $V_{COMP}=1.5\text{ V}$ | 10 | 20 | | μA |
| | | $V_{INV}=1.5\text{ V}$, | 550 | 800 | | |
| | Sink Current | $V_{INV}=2.65\text{ V}$, $V_{COMP}=5\text{ V}$ | 10 | 20 | | |
| Current-Sense Section | | | | | | |
| V_{PK} | Threshold Voltage for Peak Current Limit Cycle-by-Cycle Limit | | 0.77 | 0.82 | 0.87 | V |
| t_{PD} | Propagation Delay | | | | 200 | ns |
| t_{LEB} | Leading-Edge Blanking Time | $R_{MOT}=24\text{ k}\Omega$, $V_{COMP}=5\text{ V}$ | | 400 | 500 | ns |
| | | $R_{MOT}=24\text{ k}\Omega$, $V_{COMP}=V_{OZ}+50\text{ mV}$ | | 270 | 350 | |
| Gate Section | | | | | | |
| V_{Z-OUT} | Output Voltage Maximum (Clamp) | $V_{CC}=25\text{ V}$ | 14.5 | 16.0 | 17.5 | V |
| V_{OL} | Output Voltage Low | $V_{CC}=15\text{ V}$, $I_O=100\text{ mA}$ | | | 1.4 | V |
| V_{OH} | Output Voltage High | $V_{CC}=14\text{ V}$, $I_O=100\text{ mA}$ | 8 | | | V |
| t_R | Rising Time | $V_{CC}=12\text{ V}$, $C_L=3\text{ nF}$, 20~80% | | 80 | | ns |
| t_F | Falling Time | $V_{CC}=12\text{ V}$, $C_L=3\text{ nF}$, 80~20% | | 40 | | ns |

Continued on the following page...

Electrical Characteristics

Unless otherwise noted, $V_{CC}=15\text{ V}$ and $T_J=-40^\circ\text{C}$ to 125°C . Current is defined as positive into the device and negative out of the device.

| Symbol | Parameter | Conditions | Min. | Typ. | Max. | Units |
|---------------------------------------|--|--|------|------|------|---------------|
| Zero Current Detection Section | | | | | | |
| V_{ZCD} | Input Threshold Voltage Rising Edge | V_{ZCD} Increasing | 1.9 | 2.1 | 2.3 | V |
| H_{YS} of V_{ZCD} | Threshold Voltage Hysteresis | V_{ZCD} Decreasing | | 0.35 | | V |
| $V_{ZCD-HIGH}$ | Upper Clamp Voltage | $I_{ZCD}=3\text{ mA}$ | | | 12 | V |
| $V_{ZCD-LOW}$ | Lower Clamp Voltage | $I_{ZCD}=-1.5\text{ mA}$ | 0.3 | | | V |
| t_{DEAD} | Maximum Delay, ZCD to Output Turn-On | $V_{COMP}=5\text{ V}$, $f_{SW}=60\text{ KHz}$ | 100 | | 400 | ns |
| $t_{RESTART}$ | Restart Time | Output Turned Off by ZCD | 300 | 500 | 700 | μs |
| t_{INHIB} | Inhibit Time (Maximum Switching Frequency Limit) | $R_{MOT}=24\text{ k}\Omega$ | | 2.8 | | μs |
| V_{DIS} | Disable Threshold Voltage | | 130 | 200 | 250 | mV |
| $t_{ZCD-DIS}$ | Disable Function Debounce Time | $R_{MOT}=24\text{ k}\Omega$, $V_{ZCD}=100\text{ mV}$ | 800 | | | μs |
| Maximum On Time Section | | | | | | |
| V_{MOT} | Maximum On Time Voltage | | 1.25 | 1.30 | 1.35 | V |
| t_{ON-MAX} | Maximum On Time Programming (Resistor Based) | $R_{MOT}=24\text{ k}\Omega$, $V_{CS}=0\text{ V}$, $V_{COMP}=5\text{ V}$ | | 25 | | μs |

Typical Performance Characteristics

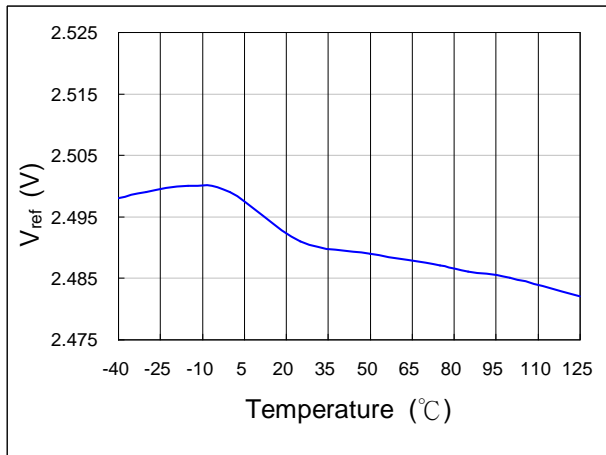

Figure 5. V_{REF} vs. T_A

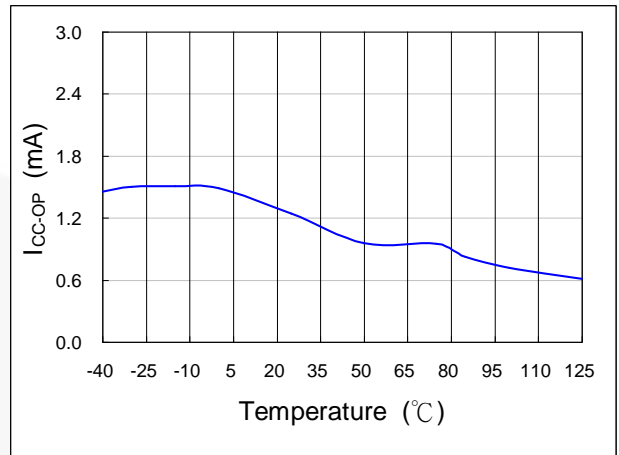

Figure 6. I_{CC-OP} vs. T_A

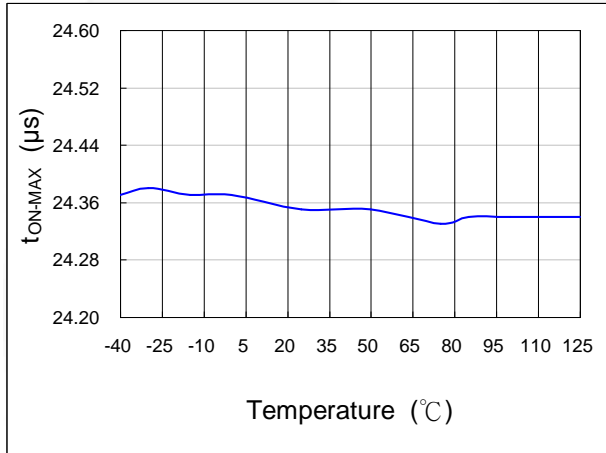

Figure 7. t_{ON-MAX} vs. T_A

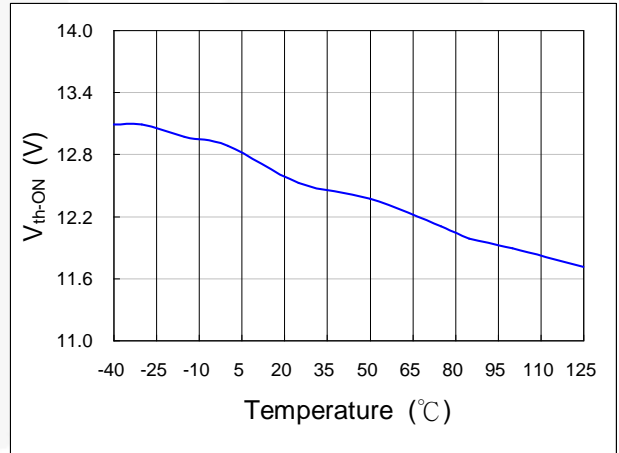

Figure 8. V_{th-ON} vs. T_A

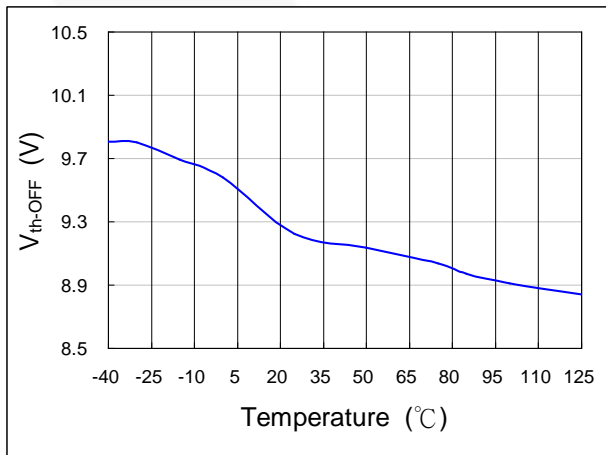

Figure 9. V_{th-OFF} vs. T_A

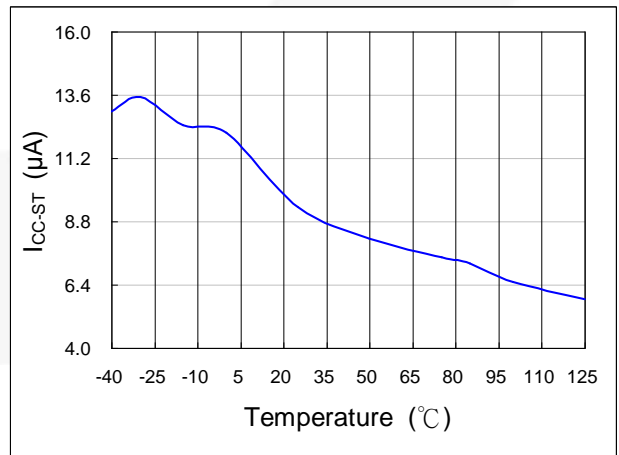

Figure 10. I_{CC-ST} vs. T_A

Typical Performance Characteristics (Continued)

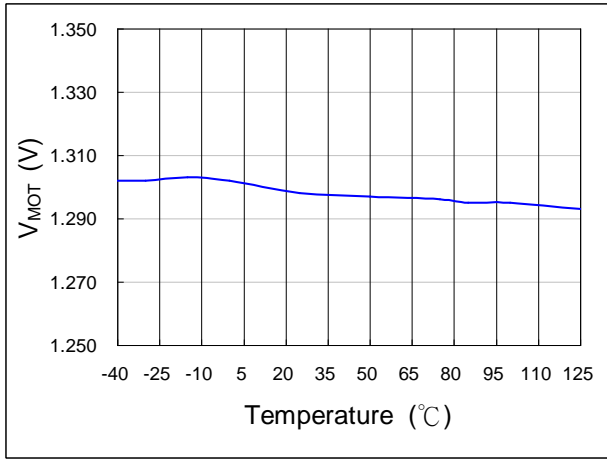

Figure 11. V_{MOT} vs. T_A

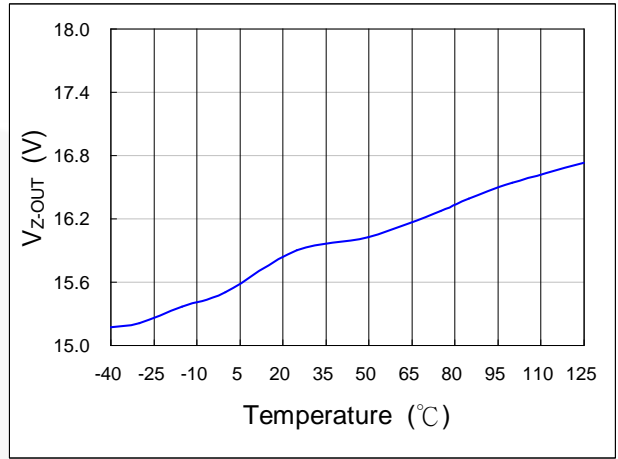

Figure 12. V_{Z-OUT} vs. T_A

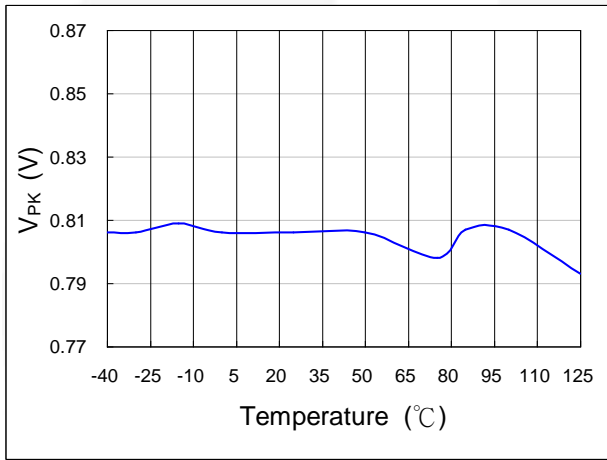

Figure 13. V_{PK} vs. T_A

Functional Description

Error Amplifier

The inverting input of the error amplifier is referenced to INV. The output of the error amplifier is referenced to COMP. The non-inverting input is internally connected to a fixed $2.5\text{ V} \pm 2\%$ voltage. The output of the error amplifier is used to determine the on-time of the PWM output and regulate the output voltage. To achieve a low input current THD, the variation of the on time within one input AC cycle should be very small. A multi-vector error amplifier is built in to provide fast transient response and precise output voltage clamping.

For FAN6961, connecting a capacitance, such as $1\ \mu\text{F}$, between COMP and GND is suggested. The error amplifier is a trans-conductance amplifier that converts voltage to current with a $125\ \mu\text{mho}$.

Startup Current

Typical startup current is less than $20\ \mu\text{A}$. This ultra-low startup current allows the usage of high resistance, low-wattage startup resistor. For example, $1\ \text{M}\Omega/0.25\ \text{W}$ startup resistor and a $10\ \mu\text{F}/25\ \text{V}$ (V_{CC} hold-up) capacitor are recommended for an AC-to-DC power adaptor with a wide input range $85\text{-}265\ V_{\text{AC}}$.

Operating Current

Operating current is typically $4.5\ \text{mA}$. The low operating current enables a better efficiency and reduces the requirement of V_{CC} hold-up capacitance.

Maximum On-Time Operation

Given a fixed inductor value and maximum output power, the relationship between on-time and line voltage is:

$$t_{on} = \frac{2 \cdot L \cdot P_o}{V_{rms}^2 \cdot \eta} \quad (1)$$

If the line voltage is too low or the inductor value is too high, t_{ON} is too long. To avoid extra low operating frequency and achieve brownout protection, the maximum value of t_{ON} is programmable by one resistor, R_I , connected between MOT and GND. A $24\ \text{k}\Omega$ resistor R_I generates corresponds to $25\ \mu\text{s}$ maximum on time:

$$t_{on(max)} = R_I(k\Omega) \cdot \frac{25}{24}(\mu\text{s}) \quad (2)$$

The range of the maximum on-time is designed as $10 \sim 50\ \mu\text{s}$.

Peak Current Limiting

The switch current is sensed by one resistor. The signal is feed into CS pin and an input terminal of a comparator. A high voltage in CS pin terminates a switching cycle immediately and cycle-by-cycle current limit is achieved. The designed threshold of the protection point is $0.82\ \text{V}$.

Leading-Edge Blanking (LEB)

A turn-on spike on CS pin appears when the power MOSFET is switched on. At the beginning of each switching pulse, the current-limit comparator is disabled for around 400ns to avoid premature termination. The gate drive output cannot be switched off during the blanking period. Conventional RC filtering is not necessary, so the propagation delay of current limit protection can be minimized.

Under-Voltage Lockout (UVLO)

The turn-on and turn-off threshold voltage is fixed internally at $12\ \text{V}/9.5\ \text{V}$. This hysteresis behavior guarantees a one-shot startup with proper startup resistor and hold-up capacitor. With an ultra-low startup current of $20\ \mu\text{A}$, one $1\ \text{M}\Omega\ R_{IN}$ is sufficient for startup under low input line voltage, $85\ V_{\text{rms}}$. Power dissipation on R_{IN} would be less than $0.1\ \text{W}$ even under high line ($V_{\text{AC}}=265\ V_{\text{rms}}$) condition.

Output Driver

With low on resistance and high current driving capability, the output driver can drive an external capacitive load larger than $3000\ \text{pF}$. Cross conduction current has been avoided to minimize heat dissipation, improving efficiency and reliability. This output driver is internally clamped by a $16.5\ \text{V}$ Zener diode.

Zero-Current Detection (ZCD)

The zero-current detection of the inductor is achieved using its auxiliary winding. When the stored energy of the inductor is fully released to output, the voltage on ZCD goes down and a new switching cycle is enabled after a ZCD trigger. The power MOSFET is always turned on with zero inductor current such that turn-on loss and noise can be minimized. The converter works in boundary-mode and peak inductor current is always exactly twice of the average current. A natural power factor correction function is achieved with the low-bandwidth, on-time modulation. An inherent maximum off time is built in to ensure proper startup operation. This ZCD pin can be used as a synchronous input.

Noise Immunity

Noise on the current sense or control signal can cause significant pulse-width jitter, particularly in the boundary-mode operation. Slope compensation and built-in debounce circuit can alleviate this problem. Because the FAN6961 has a single ground pin, high sink current at the output cannot be returned separately. Good high-frequency or RF layout practices should be followed. Avoiding long PCB traces and component leads, locating compensation and filter components near to the FAN6961, and increasing the power MOSFET gate resistance improve performance.

Reference Circuit

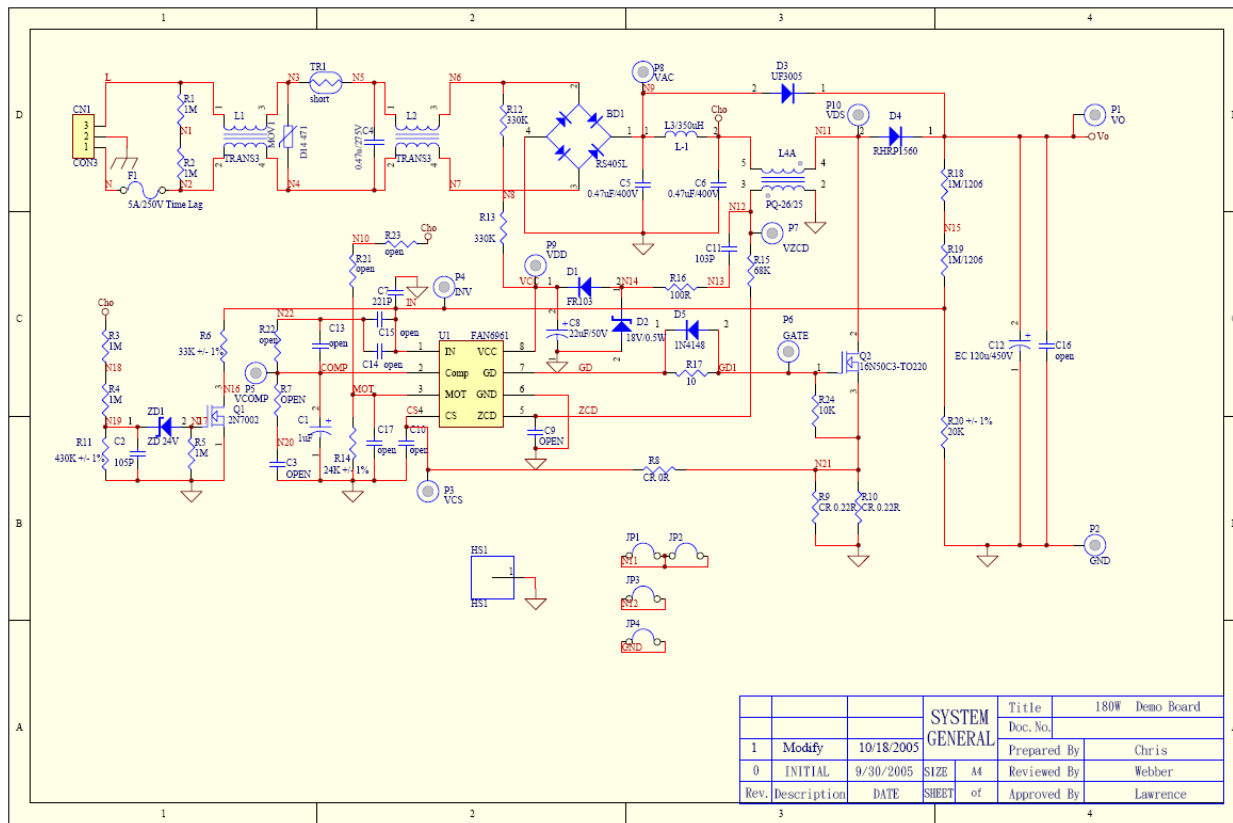
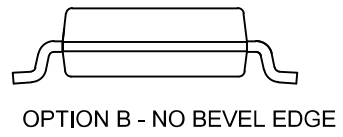
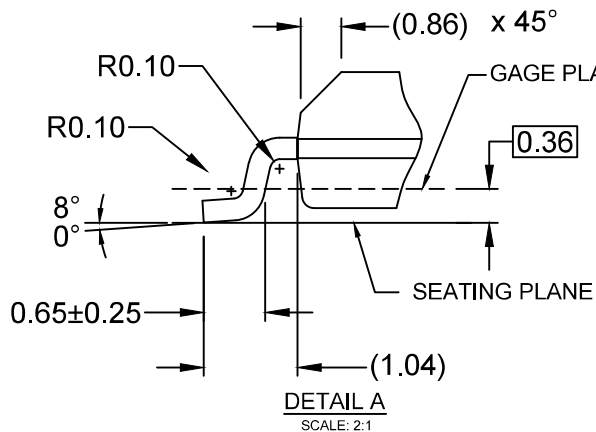
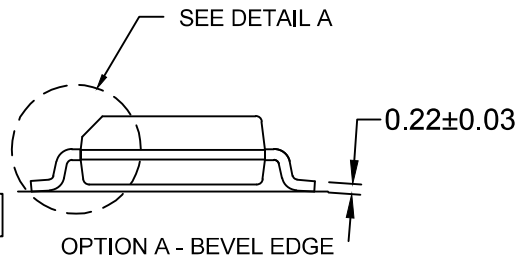
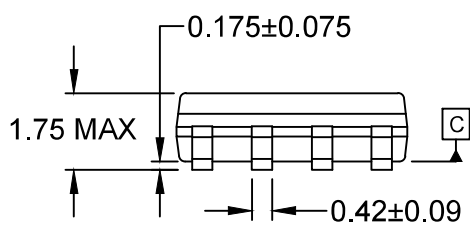
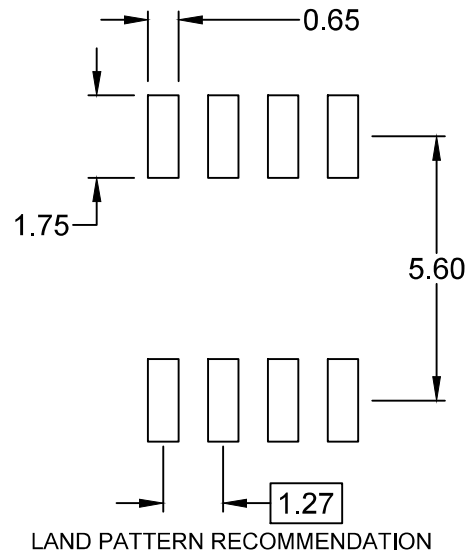
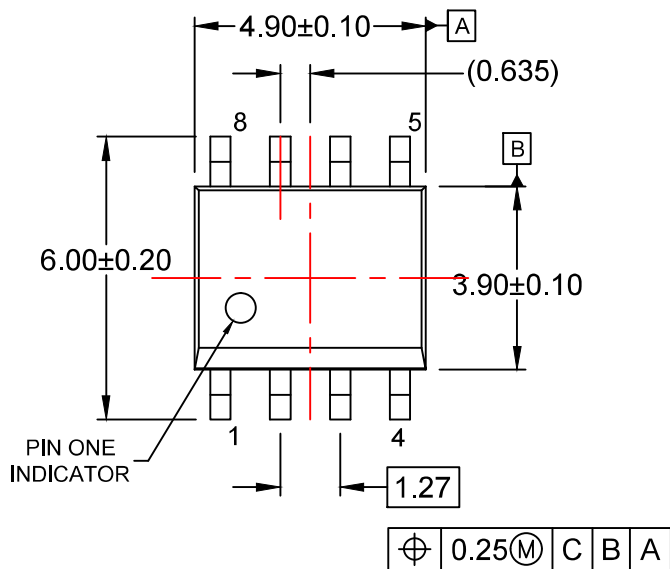
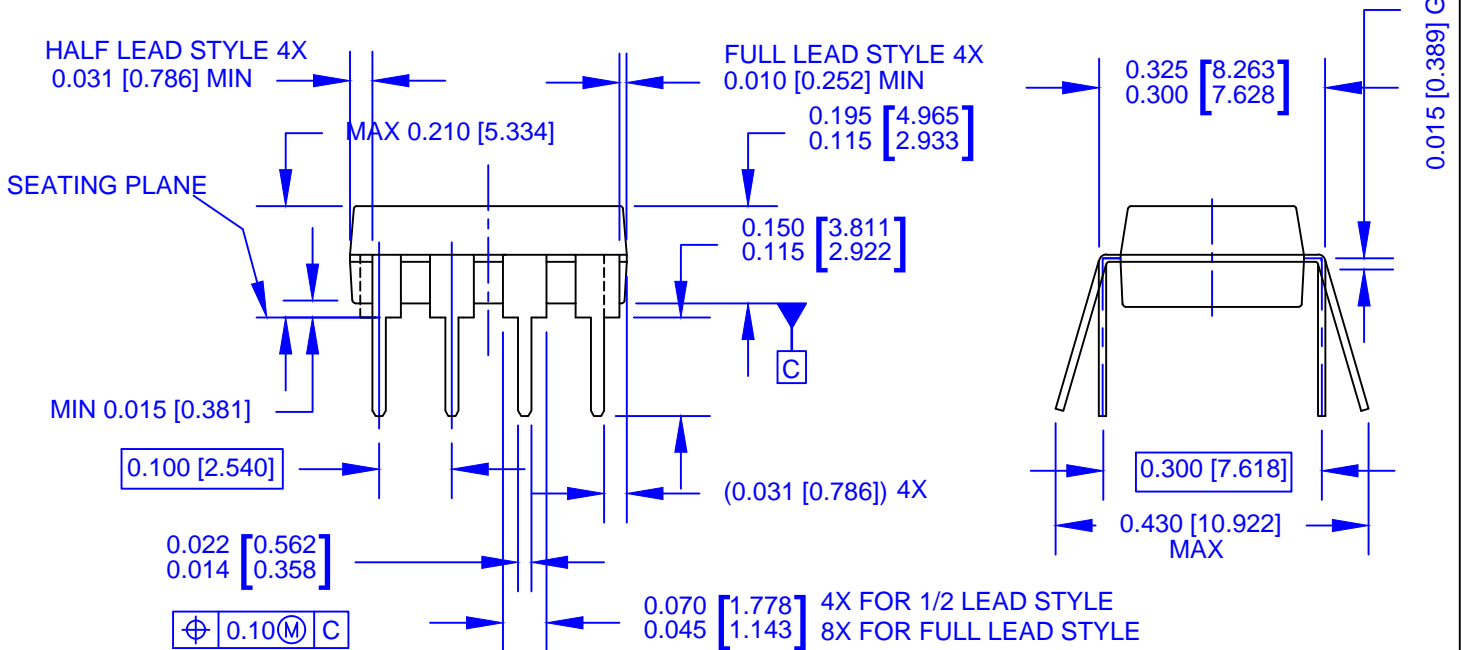
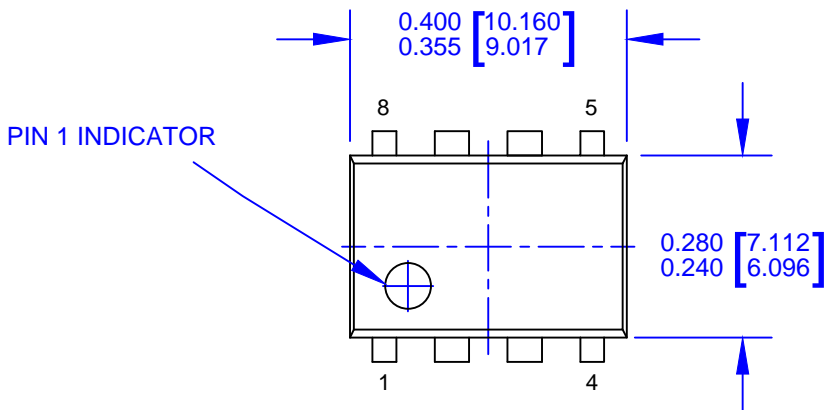

Figure 14. Reference Circuit



- NOTES:
- A) THIS PACKAGE CONFORMS TO JEDEC MS-012, VARIATION AA.
 - B) ALL DIMENSIONS ARE IN MILLIMETERS.
 - C) DIMENSIONS DO NOT INCLUDE MOLD FLASH OR BURRS.
 - D) LANDPATTERN STANDARD: SOIC127P600X175-8M
 - E) DRAWING FILENAME: M08Arev16





NOTES:

- A) THIS PACKAGE CONFORMS TO JEDEC MS-001 VARIATION BA WHICH DEFINES 2 VERSIONS OF THE PACKAGE TERMINAL STYLE WHICH ARE SHOWN HERE.
- B) CONTROLLING DIMS ARE IN INCHES
- C) DIMENSIONS ARE EXCLUSIVE OF BURRS, MOLD FLASH, AND TIE BAR EXTRUSIONS.
- D) DIMENSIONS AND TOLERANCES PER ASME Y14.5M-2009
- E) DRAWING FILENAME AND REVISION: MKT-N08MREV2.



ON Semiconductor and  are trademarks of Semiconductor Components Industries, LLC dba ON Semiconductor or its subsidiaries in the United States and/or other countries. ON Semiconductor owns the rights to a number of patents, trademarks, copyrights, trade secrets, and other intellectual property. A listing of ON Semiconductor's product/patent coverage may be accessed at www.onsemi.com/site/pdf/Patent-Marking.pdf. ON Semiconductor reserves the right to make changes without further notice to any products herein. ON Semiconductor makes no warranty, representation or guarantee regarding the suitability of its products for any particular purpose, nor does ON Semiconductor assume any liability arising out of the application or use of any product or circuit, and specifically disclaims any and all liability, including without limitation special, consequential or incidental damages. Buyer is responsible for its products and applications using ON Semiconductor products, including compliance with all laws, regulations and safety requirements or standards, regardless of any support or applications information provided by ON Semiconductor. "Typical" parameters which may be provided in ON Semiconductor data sheets and/or specifications can and do vary in different applications and actual performance may vary over time. All operating parameters, including "Typicals" must be validated for each customer application by customer's technical experts. ON Semiconductor does not convey any license under its patent rights nor the rights of others. ON Semiconductor products are not designed, intended, or authorized for use as a critical component in life support systems or any FDA Class 3 medical devices or medical devices with a same or similar classification in a foreign jurisdiction or any devices intended for implantation in the human body. Should Buyer purchase or use ON Semiconductor products for any such unintended or unauthorized application, Buyer shall indemnify and hold ON Semiconductor and its officers, employees, subsidiaries, affiliates, and distributors harmless against all claims, costs, damages, and expenses, and reasonable attorney fees arising out of, directly or indirectly, any claim of personal injury or death associated with such unintended or unauthorized use, even if such claim alleges that ON Semiconductor was negligent regarding the design or manufacture of the part. ON Semiconductor is an Equal Opportunity/Affirmative Action Employer. This literature is subject to all applicable copyright laws and is not for resale in any manner.

PUBLICATION ORDERING INFORMATION

LITERATURE FULFILLMENT:

Literature Distribution Center for ON Semiconductor
19521 E. 32nd Pkwy, Aurora, Colorado 80011 USA
Phone: 303-675-2175 or 800-344-3860 Toll Free USA/Canada
Fax: 303-675-2176 or 800-344-3867 Toll Free USA/Canada
Email: orderlit@onsemi.com

N. American Technical Support: 800-282-9855 Toll Free
USA/Canada
Europe, Middle East and Africa Technical Support:
Phone: 421 33 790 2910
Japan Customer Focus Center
Phone: 81-3-5817-1050

ON Semiconductor Website: www.onsemi.com
Order Literature: <http://www.onsemi.com/orderlit>
For additional information, please contact your local
Sales Representative

Looking for pricing, stock, or lifecycle information?

Click below to explore more details on WIN SOURCE:

-  [View FAN6961SZ on WIN SOURCE](#)
-  [Fairchild/ON Semiconductor Information](#)

Optimize Your Supply Chain with WIN SOURCE Solutions

-  Global Sourcing Solution
-  Obsolete Management
-  Cost Control Management
-  Shortage Management
-  Alternative Solution
-  Excess Inventory Management