

Magnetic Proportion System / Compact size and High-speed response

LA01M SERIES

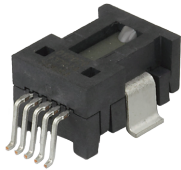

ABSOLUTE MAXIMUM RATINGS

Parameters	Symbol	Unit	Value	Comment
Supply voltage	V _{DD}	V	6	
Jumper temperature	—	°C	120	
Output current	I _{out}	mA	± 1	Recommend ; < ± 0.5mA
ESD rating (HBM: Human Body Model)	—	kV	2	C=100pF, R=1.5k Ω

ISOLATION CHARACTERISTICS

Parameters	Symbol	Unit	Value	Comment
Insulation voltage	V _d	V	≥ AC2500V, 50/60Hz, for 1minute (Sensing current 0.5mA)	Primary ⇔ Secondary
Impulse withstand voltage	V _w	kV	2.5	Primary ⇔ Secondary Input waveform : • Front time 1.2μs • Time to half value 50μs • single
Clearance distance	d _{ci}	mm	2.0	Primary ⇔ Secondary
Creepage distance	d _{cp}	mm	2.0	Primary ⇔ Secondary
Case material	—	—	UL94 V-0	
Comparative Tracking Index : (CTI)	CTI	V	200	

ENVIRONMENTAL AND MECHANICAL CHARACTERISTICS

Parameters	Symbol	Unit	Value			Comment
			MIN	TYP	MAX	
Ambient operating temperature	T _a	°C	- 40		+ 90	
Ambient storage temperature	T _s	°C	- 40		+ 125	
Mass	m	g		2		

SPECIFICATIONS

T_a=+25°C, V_{DD}=+5V, R_L≥10MΩ

Parameters	Symbol	Unit	Value			Comment
			MIN	TYP	MAX	
Measurement current range	LA01M021S05	I _f	A	- 21		21
	LA01M032S05			- 31.8		31.8
	LA01M035S05			- 35		35
	LA01M041S05			- 41		41
Maximum primary current (RMS)	I _{p (RMS) max}	A			20	

SPECIFICATIONS

Ta=+25°C, V_{DD}=+5V, RL≥10MΩ

Parameters	Symbol	Unit	Value			Comment	
			MIN	TYP	MAX		
Supply Voltage	V _{DD}	V	4.5	5.0	5.5		
Number of primary turns	N _p	T	1				
Primary Jumper resistance	R _p	mΩ		0.34			
Current consumption (at I _p =0A)	I _{DD}	mA			10		
Offset voltage	LA01M021S05	V _{of}	V	2.390	2.500	2.610	
	LA01M032S05			2.408	2.500	2.592	
	LA01M035S05			2.423	2.500	2.577	
	LA01M041S05			2.432	2.500	2.568	
Temperature drift of offset voltage (at Ta= - 40 ~+ 90°C, Variation from V _{of} (Ta=35°C), I _p =0A)	LA01M021S05	TCV _o	mV	± 26.0			
	LA01M032S05			± 22.0			
	LA01M035S05			± 17.5			
	LA01M041S05			± 14.5			
Sensitivity	LA01M021S05	G	mV/A	98.0	100.0	102.0	
	LA01M032S05			64.7	66.0	67.3	
	LA01M035S05			58.8	60.0	61.2	
	LA01M041S05			49.0	50.0	51.0	
Temperature coefficient 1 of Sensitivity (at Ta= + 35 ~+ 90°C, Variation ratio to G (Ta=35°C))	LA01M021S05	TCG1	%	± 1.0			
	LA01M032S05			± 1.0			
	LA01M035S05			± 1.0			
	LA01M041S05			± 2.0			
Temperature coefficient 2 of Sensitivity (at Ta= - 40 ~+ 35°C, Variation ratio to G (Ta=35°C))	TCG2	%		± 2.0			
Output Linearity (at 0... I _f)	ε _L	%	- 1		1		
Output noise voltage	V _{NRMS}	mV _{rms}			2.1		
Ratiometric error of sensitivity	V _{G-R}	%	- 1		1		
Ratiometric error of offset voltage	V _{of-R}	%	- 1		1		
Response time 1 (at 90% of I _f)	t _r	μs		1		CL=100pF	
Frequency bandwidth (- 3dB)	BW	kHz		400		CL=100pF	

FUNCTIONAL BLOCK DIAGRAM

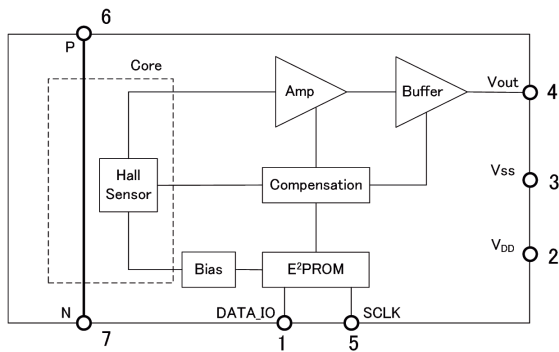

CHARACTERISTIC CURVE (TYP) AND PRIMARY CURRENT DERATING CURVE

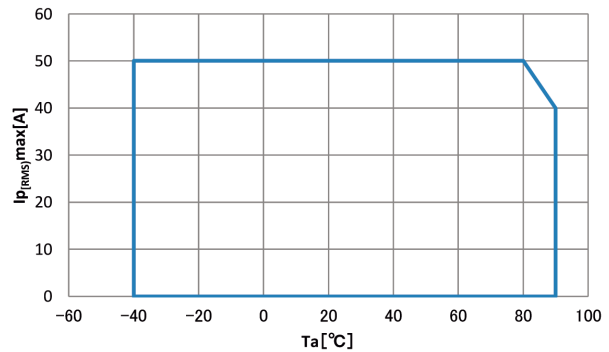
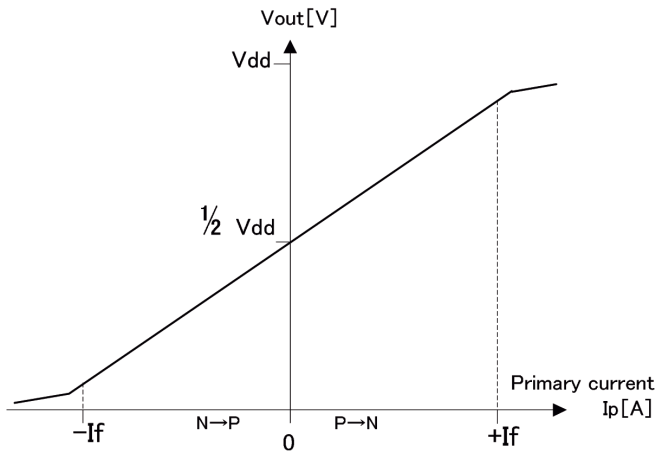

Conditions : Mounted on the test board complying with the EIA/JEDEC Standards (EIA/JESD51.)

CHARACTERISTICS DEFINITIONS

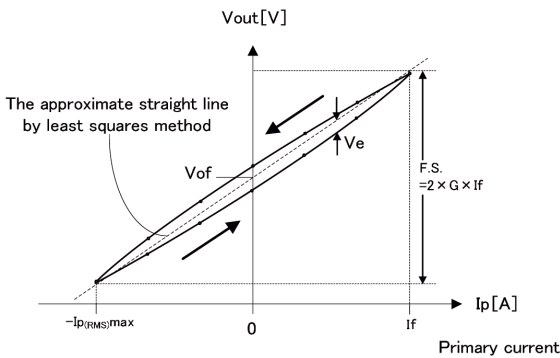

- Sensitivity G [mV/A], Offset voltage V_{of} [V]
Sensitivity (G) is defined as slope of the approximate straight line by least squares method, using the data of the output voltage (V_{out}) when sweeping the measured current I_p at rated current range.
Also Offset voltage (V_{of}) is defined as the intercept of the approximate straight line.
- Output linearity ϵ_L [%]
Output linearity (ϵ_L) is defined as the ratio of maximum error voltage (V_e) to the full scale (F.S.), where V_d is maximum difference between the Output voltage (V_{out}) and the approximate straight line calculated in the sensitivity and offset voltage definition;
$$\epsilon_L = V_e / F.S. \times 100$$
- Ratiometric error of sensitivity V_{G-R} [%], ratiometric error of Offset voltage V_{of-R} [%]
Output of LA01M Series is ratiometric.
Sensitivity (G) and Offset voltage (V_{of}) are proportional to Supply voltage (V_{DD}).
- Ratiometric error is defined as follows in the supply voltage range ($4.5V < V_{DD} < 5.5V$);
$$V_{G-R} = 100 \times [(G(V_{DD}=V_{DD1}) / G(V_{DD}=5V)) - (V_{DD1} / 5)] / (V_{DD1} / 5)$$

$$V_{of-R} = 100 \times [V_{of}(V_{DD}=V_{DD1}) - V_{of}(V_{DD}=5V) \times (V_{DD1} / 5)] / F.S.$$

TERMINAL DESCRIPTIONS

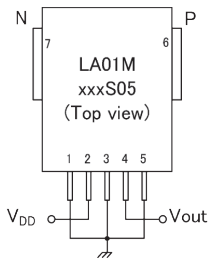

Terminal number	Description
① DATA_IO	Test pin (connect to GND)
② V _{DD}	Power supply (5V)
③ V _{SS}	GND (0V)
④ Vout	Analog output
⑤ SCLK	Test pin (connect to GND)
⑥ P	Input
⑦ N	Output

DIMENSIONS (mm)

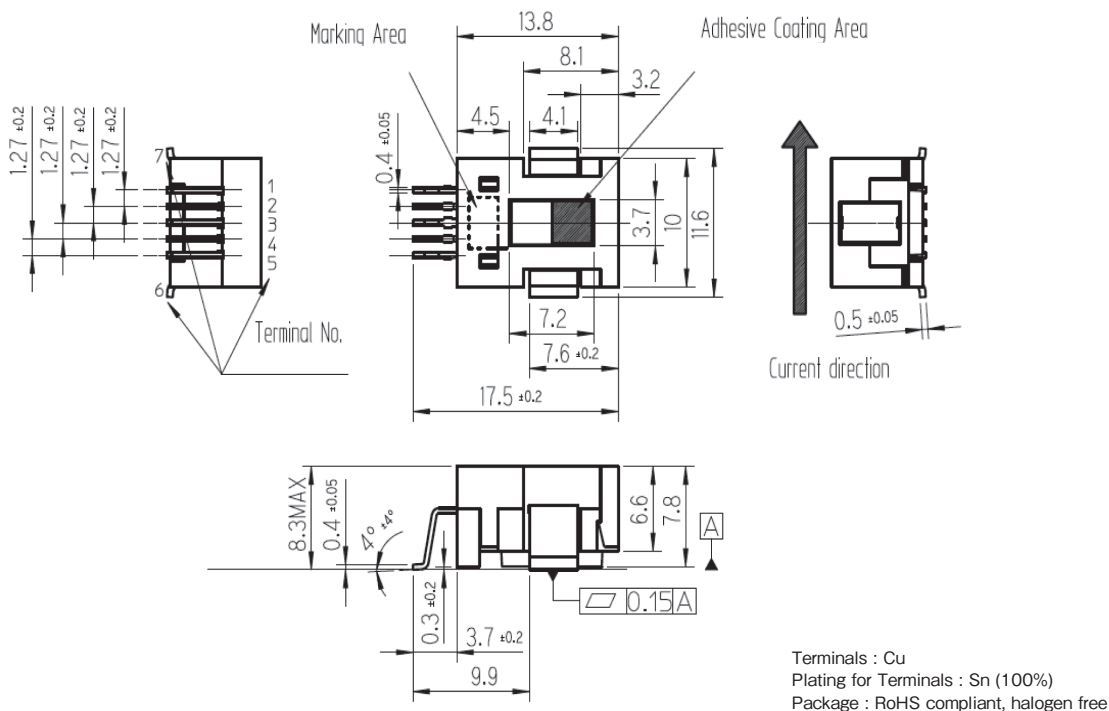

Note1) The tolerances of dimensions without any mention are ± 0.1mm.
 Note2) The adhesive material (RoHS compliant, halogen free) is used for holding the magnetic core.

RECOMMENDED THROUGH-HOLE LAYOUTS (mm)

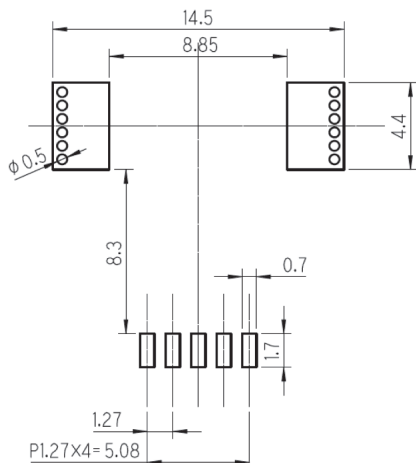

Note) If 2 or more trace layers are used as the current path, please make enough number of through-holes to flow current between the trace layers.

TYPICAL APPLICATION

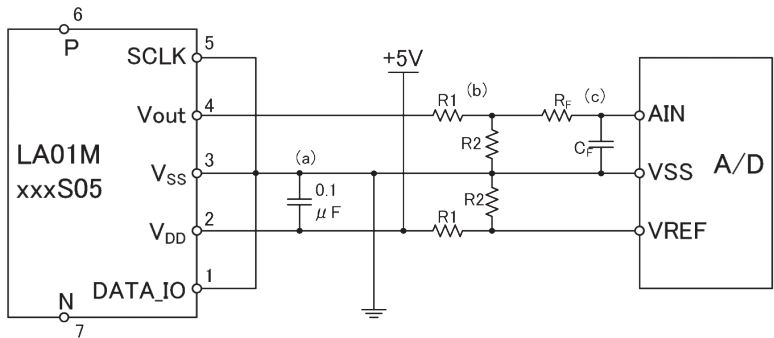

- (a) Please be placed the bypass capacitor 0.1 μF as close as possible to the VDD and VSS pins of LA01M Series.
- (b) LA01M Series have a ratiometric output. When received output by the A / D converter , it is possible to reduce the A / D conversion error due to supply voltage fluctuations by setting a common voltage level of the A / D converter and supply voltage. The resistive divider with R1 and R2 is required, if the reference voltage of the A / D converter is lower than + 5V.
- (c) If necessary, please insert a low-pass filter to Vout.

TYPE DESIGNATION

LA01 M *** S 05
 ① ② ③ ④ ⑤

- ① Model (4 figures)
LA01 : Series
- ② Mounting configuration (1 figure)
M : Surface mount type
- ③ Measurement current range (3 figures)
Ex) 035 : 35A 100 : 100A
- ④ Control power supply type (1 figure)
S : Single supply
- ⑤ Power supply voltage (2 digits)

Important Notice

1. The content of this information is subject to change without prior notice for the purpose of improvements, etc. Ensure that you are in possession of the most up-to-date information when using this product.
2. This product is intended to be used in general electronics applications (electric home appliances, business equipment, information equipment, communication terminal equipment, measuring devices, industrial equipment, and so on). This product is neither intended nor warranted for use in following equipment or devices:

Special application (such as for medical devices, transportation equipment, traffic signal control equipment, fire and crime prevention equipment, aeronautics and space devices, nuclear power control, fuel control, in-vehicle equipment, safety devices, and so on) in which extremely high quality and high reliability is required, or if the malfunction or failures of product could be cause loss of human life, bodily injury.

Tamura Corporation shall not be held responsible for any damage incurred by customers or any third party when products are used in special application, unless specifically permitted in this document.
3. Tamura Corporation constantly strives to improve quality and reliability, but malfunction or failures are bound to occur with some probability in current sensor. To ensure that failures do not cause accidents resulting in injury or death, fire accidents, social damage, and so on, users are to thoroughly verify the safety of their designs in devices and/or systems.
4. The operation examples and circuit examples shown in this information are for reference purposes only, and Tamura Corporation disclaims all responsibility for any violations of industrial property rights, intellectual property rights and any other rights owned by Tamura Corporation or third parties that these may entail.
5. The circuit examples and part constants listed in these specifications are provided as reference for the verification of characteristics. The user is to perform design, verification, and judgment under his or her own responsibility, taking into account the various conditions.
6. The products are designed for use in environments where consumer electronics are commonly used. It is not designed for use in special environments such as listed below, and if such use is considered, the user is to perform thorough safety and reliability checks under his/her responsibility.
7. This product is not designed to resist radiation.
 - Use in liquids such as water, oil, chemical solutions, or organic solvents, and use in locations where the product will be exposed to such liquids.
 - Use that involves exposure to direct sunlight, outdoor exposure, or dusty conditions.
 - Use in locations where corrosive gases such as sea winds, Cl₂, H₂S, NH₃, SO₂, or NO₂, are present. (Some product improves durability)
 - Use in environments with strong static electricity or electromagnetic radiation.
 - Use that involves placing inflammable material next to the product.
 - Use of this product either sealed with a resin filling or coated with resin.
 - Use of water or a water soluble detergent for flux cleaning.
 - Use in locations where condensation is liable to occur.
8. Do not use or otherwise make available the TAMURA products or the technology described in this document for any military purposes, including without limitation, for the design, development, use, stockpiling or manufacturing of mass destruction weapons (e.g. nuclear, chemical, or biological weapons or missile technology products). When exporting and re-exporting the products or technology described in this document, you should comply with the applicable export control laws and regulations and follow the procedures required by such laws and regulations including, without limitation, Japan -Foreign Exchange and Foreign Trade Control Law and U.S.-Export Administration Regulations. The TAMURA products and related technology should not be used for or incorporated into any products or systems whose manufacture, use, or sale is prohibited under any applicable domestic or foreign laws or regulations.
9. Please contact your TAMURA sales office for details as to environmental matters such as the RoHS compatibility of Product. Please use TAMURA products in compliance with all applicable laws and regulations that regulate the inclusion or use of controlled substances, including without limitation, the EU RoHS Directive. TAMURA assumes no liability for damages or losses occurring as a result of your noncompliance with applicable laws and regulations.
10. TAMURA assumes no liability for damages or losses incurred by you or third parties as a result of unauthorized use of TAMURA products.
11. This document and any information herein may not be reproduced in whole or in part without prior written permission from TAMURA.

Application notes

<General Considerations>

1. The sensor uses polar electronic components. When the polarity of the power supply is mistaken, the sensor is damaged.
2. Static electricity or excessive voltage can increase an offset voltage in the Hall element, and cause offset voltage to change. Please exercise care in handling and application.
3. In order to prevent the influence of noise, the use of twisted cable or shielded cable for the output line is recommended
4. If using this device within a magnetic field generated by other devices, the specified accuracy may not be obtainable.
5. Our products (several models are excluded) are adjusted with the trimming method by the measurement condition (Load resistance, Power supply voltage) of specification sheets. Therefore, characteristics (Offset, Output, etc.) and its deviation may be changed in different circuit conditions from the measurement condition. All change characteristic items are not indicated on specification sheets.
6. The performance of current sensors with through-hole (aperture) is dependent on the position of the primary conductor. Tamura specifications are based on a primary conductor completely filling the through-hole (aperture) area.
7. The current sensor rated current in DC Amps.
8. Please use mating connector with equivalent terminal plating material to insure proper operation and avoid possibility of 'galvanic corrosion' .
9. Please do not store in high-temperature and high-humidity storage environment. Please use it after confirming soldering when it is kept for six months or more. (product soldered with substrate)
10. We recommend performing a zero offset adjustment by measuring the offset voltage at startup. In continuously operation for a few months, or at change of ambient temperature or humidity is large, we recommend regularly performing a zero offset adjustment at being idling (it is clear that the current is not apply) .
11. The current sensor doesn't have built-in protection circuit (devices and fuses, etc.). As a failure mode of the sensor, there is a short circuit and open state. In the case of a short-circuit state, the abnor-mal temperature rise of the internal parts is assumed, and there is a possibility to smoke and to ignite. If it is used in safety critical circuit blocks, please take appropriate measures by protection devices, protection circuits, etc. For closed loop -type sensors and flux gate (closed loop type) sensors, the consumption current of the secondary power supply varies in proportion to the measurement current.

<Open loop>

1. High frequency primary current may result in excessive heating in iron magnetic core and cause damage to internal circuitry; for high frequency applications select current sensor with ferrite core material.
2. If the measured current exceeds the rated current, magnetic core saturation will occur and the output voltage signal will not be linearly proportional to the measured current.

<Closed Loop>



1. For closed loop current sensors please insure the power supply voltage is balanced, symmetrical, and, applied simultaneously to avoid potential increase in DC offset error.
2. Maximum rated current measurement duration is timedependent. Maximum rated current applied in excess of the time limit can result in damage to internal electronic circuitry; please consult Tamura for assistance.
3. When using a measurement resistor to convert current output to voltage output select a resistor with stable temperature characteristic to insure accuracy of the output voltage.
4. Compensation current supplied to the secondary winding varies in proportion to the measured current based on the conversion ratio. (If/KN; KN = secondary turns) Please insure the PSU has required current capacity to supply compensation current to the secondary winding.

<Flux-Gate>

1. Compensation current supplied to the secondary winding varies in proportion to the measured current. Please insure the PSU has required current capacity to supply compensation current to the secondary winding.
2. There is 450kHz ripple voltage present on the output and reference output voltage signals . An external capacitor maybe added if necessary.

Looking for pricing, stock, or lifecycle information?

Click below to explore more details on WIN SOURCE:

-  [View LA01M035S05 on WIN SOURCE](#)
-  [Tamura Information](#)

Optimize Your Supply Chain with WIN SOURCE Solutions

-  Global Sourcing Solution
-  Obsolete Management
-  Cost Control Management
-  Shortage Management
-  Alternative Solution
-  Excess Inventory Management