



**THE DATASHEET OF  
AH288-PL-B**



**Features**

- On chip Hall sensor
- Rotor-locked shutdown
- Automatically restart
- Frequency generator (FG) output
- Built-in Zener protection for output driver
- Operating voltage: 3.8V~28V
- Output current:  $I_{O(AVE)} = 400\text{mA}$
- Lead Free Package: SOT89-5L (Note 1)
- SOT89-5L: Available in "Green" Molding Compound (No Br, Sb)
- Lead Free Finish/RoHS Compliant (Note 2)

**General Description**

AH288 is a monolithic fan motor controller with Hall sensor's capability. It contains two complementary open-drain transistors as motor coil drivers, automatic lock current shutdown, and recovery protections. Additional, frequency generator (FG) output is for speed detection relatively.

Rotor-lock shutdown detection circuit turns off the output driver when the rotor is blocked to avoid coil overheat. Then, the automatic recovery circuit will restart the motor. These protected actions are repeated and periodic during the blocked period. Until the blocking is removed, the motor recovers and runs normally.

**Typical Application Circuit**

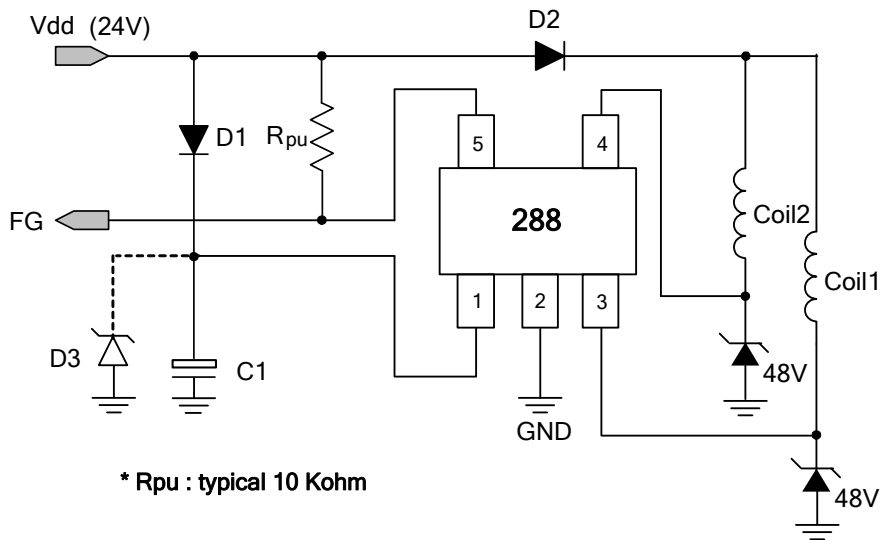

Note: The optional Capacitor C1 and Diode D3 are for power stabilization. C1 is recommended to be E-Cap.,  $1\mu\text{F}/25\text{V}$ ; D3 is recommended to be Zener Diode,  $V_z = 27\text{V}$ . Which C1 and D3 value need to be fine tuned to optimize design for different coils and power suppliers.

**24V DC Brush-less Fan with FG output function**

### Ordering Information

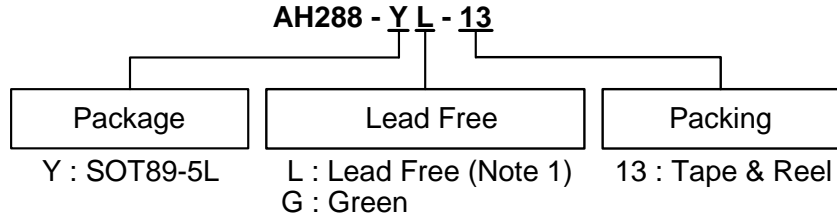

Device	Package Code	Packaging (Note 3)	13" Tape and Reel	
			Quantity	Part Number Suffix
AH288-YL-13	Y	SOT89-5L	2500/Tape & Reel	-13
AH288-YG-13	Y	SOT89-5L	2500/Tape & Reel	-13

- Notes:
- AH288-YL-13 will be replaced by AH288-YG-13
  - EU Directive 2002/95/EC (RoHS). All applicable RoHS exemptions applied. Please visit our website at [http://www.diodes.com/products/lead\\_free.html](http://www.diodes.com/products/lead_free.html).
  - Pad layout as shown on Diodes Inc. suggested pad layout document AP02001, which can be found on our website at <http://www.diodes.com/datasheets/ap02001.pdf>.
  - Reverse taping as shown on Diodes Inc. Surface Mount (SMD) Packaging document AP02007, which can be found on our website <http://www.diodes.com/datasheets/ap02007.pdf>.

### Pin Assignments

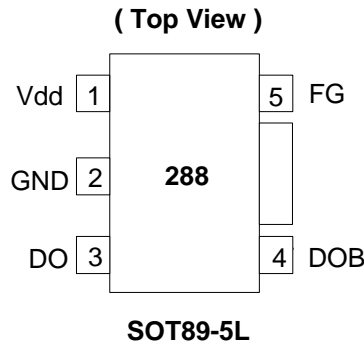

### Pin Descriptions

Pin Name	Pin No.	Description
Vdd	1	Input power
GND	2	Ground
DO	3	Output pin
DOB	4	Output pin
FG	5	Frequency generation

**Block Diagram**

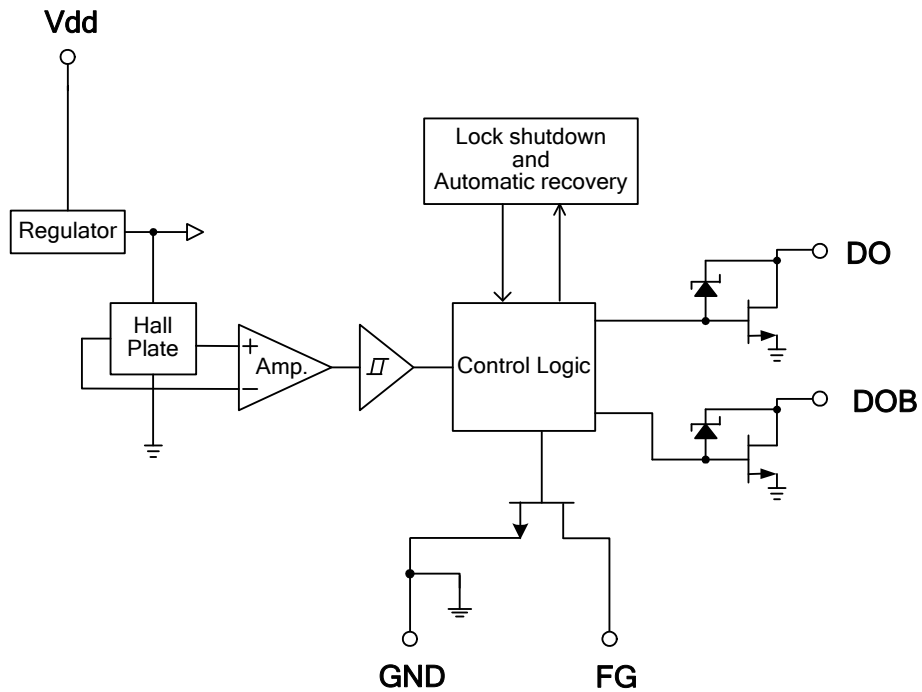

### Absolute Maximum Ratings (TA = 25°C)

Symbol	Parameter	Rating	Unit
V <sub>DD</sub>	Supply Voltage	30	V
I <sub>O</sub>	Output Current	I <sub>O(AVE)</sub>	400 mA
		I <sub>O(PEAK)</sub>	700 mA
P <sub>D</sub>	Power Dissipation	800	mW
T <sub>ST</sub>	Storage Temperature	-55 ~ 150	°C
T <sub>J</sub>	Maximum Junction Temperature	150	°C
θ <sub>JA</sub>	Thermal Resistance Junction-to-Case (Note 5)	156	°C/W

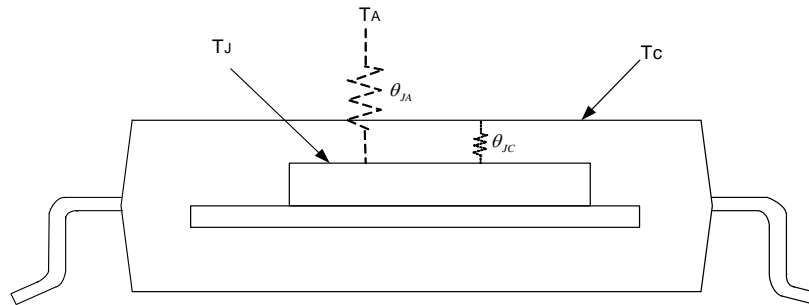

Notes: 5. θ<sub>JA</sub> should be confirmed with what heat sink thermal resistance. If no heat sink contacting, θ<sub>JA</sub> is almost the same as θ<sub>JC</sub>.

### Recommended Operating Conditions

Symbol	Characteristic	Conditions	Min	Max	Unit
V <sub>DD</sub>	Supply Voltage (Note 6)	Operating	3.8	28	V
T <sub>A</sub>	Operating Ambient Temperature	Operating	-40	100	°C

Notes: 6. Please watch out the current limit issue when the operation voltage is over 26.4V, because of the different efficiency in the coil.

**Electrical Characteristics** (TA = 25 °C, Vdd = 24V, unless otherwise specified)

Symbol	Parameter	Conditions	Min	Typ.	Max	Unit
I <sub>CC</sub>	Supply Current	Operating	-	2	4	mA
I <sub>OFF</sub>	Output Leakage Current	V <sub>OUT</sub> = 24V	-	< 0.1	10	μA
T <sub>LRP-ON</sub>	Locked Protection On		0.4	0.46	0.6	Sec
T <sub>LRP-OFF</sub>	Locked Protection Off		2.4	2.76	3.6	Sec
V <sub>OUT(SAT)</sub>	Output Saturation Voltage	I <sub>O</sub> = 200mA	-	450	700	mV
		I <sub>O</sub> = 300mA	-	680	800	
R <sub>DS(ON)</sub>	Output On Resistance	I <sub>O</sub> = 200mA	-	2.25	3.5	ohm
V <sub>OL</sub>	FG Output Vds	I <sub>O</sub> = 10mA	-	0.3	0.5	V
V <sub>Z</sub>	Output Zener-breakdown Voltage		42	55	65	V

**Truth Table**

IN-	IN+	CT	OUT1	OUT2	FG	Mode
H	L	L	H	L	H	Rotating
L	H	L	L	H	L	Rotating
-	-	H	off	off	-	Lockup protection activated

**Magnetic Characteristics** (TA = 25 °C, Vdd = 24V, unless otherwise specified, Note 7)

(1mT=10 Gauss)

Symbol	Characteristics	Min	Typ.	Max	Unit
Bop	Operate Point	10	30	60	Gauss
Brp	Release Point	-60	-30	-10	Gauss
Bhy	Hysteresis	-	60	-	Gauss

Notes: 7. Magnetic characteristics are for design information, which will vary with supply voltage, operating temperature and after soldering.

**Operating Characteristics**

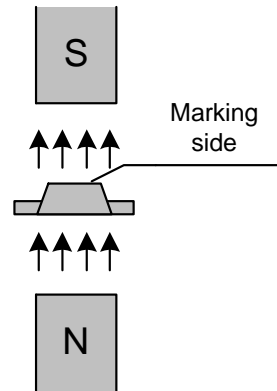
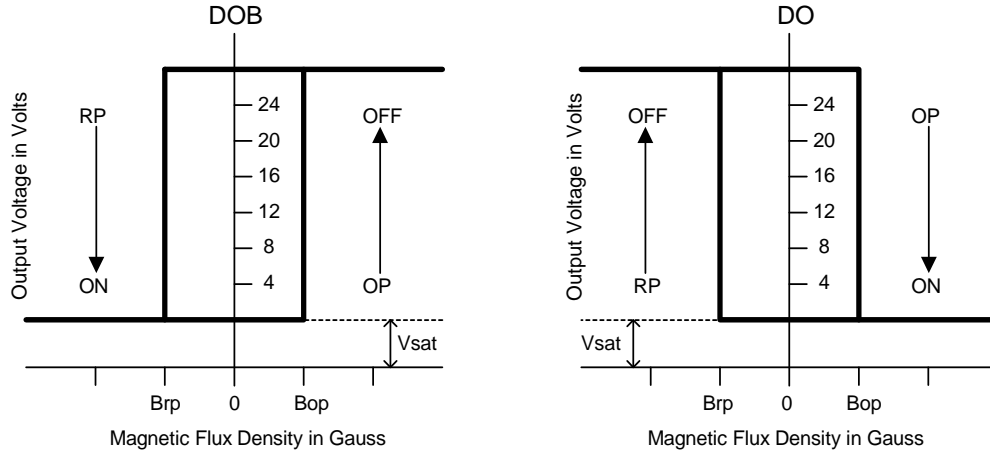

**( SOT89-5L )**

**Performance Characteristics (SOT89-5L)**

T <sub>A</sub> (°C)	25	50	60	70	75	80	85	90	95	100
P <sub>D</sub> (mW)	800	640	576	512	480	448	416	384	352	320
T <sub>A</sub> (°C)	105	110	115	120	125	130	135	140	145	150
P <sub>D</sub> (mW)	288	256	224	192	160	128	96	64	32	0

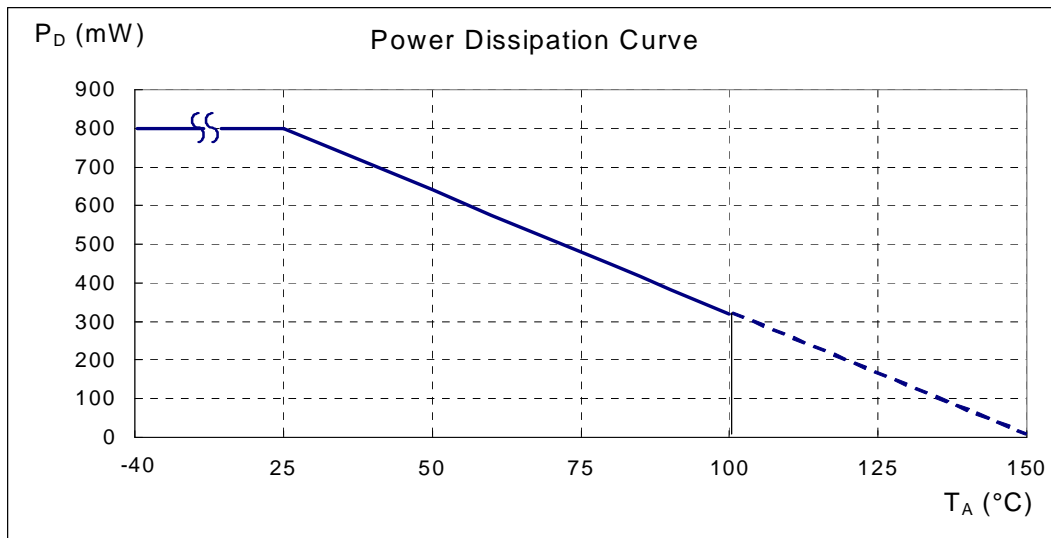

**Marking Information**

(1) SOT89-5L

( Top View )

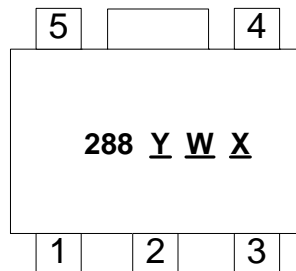

Y : Year : 0~9  
W : Week : A~Z : 1~26 week;  
 a~z : 27~52 week;  
 z represents 52 and 53 week  
X : Internal code  
 a~z : Lead Free  
 A~Z : Green

**Package Information (All Dimensions in mm)**

**(1) Package type: SOT89-5L**

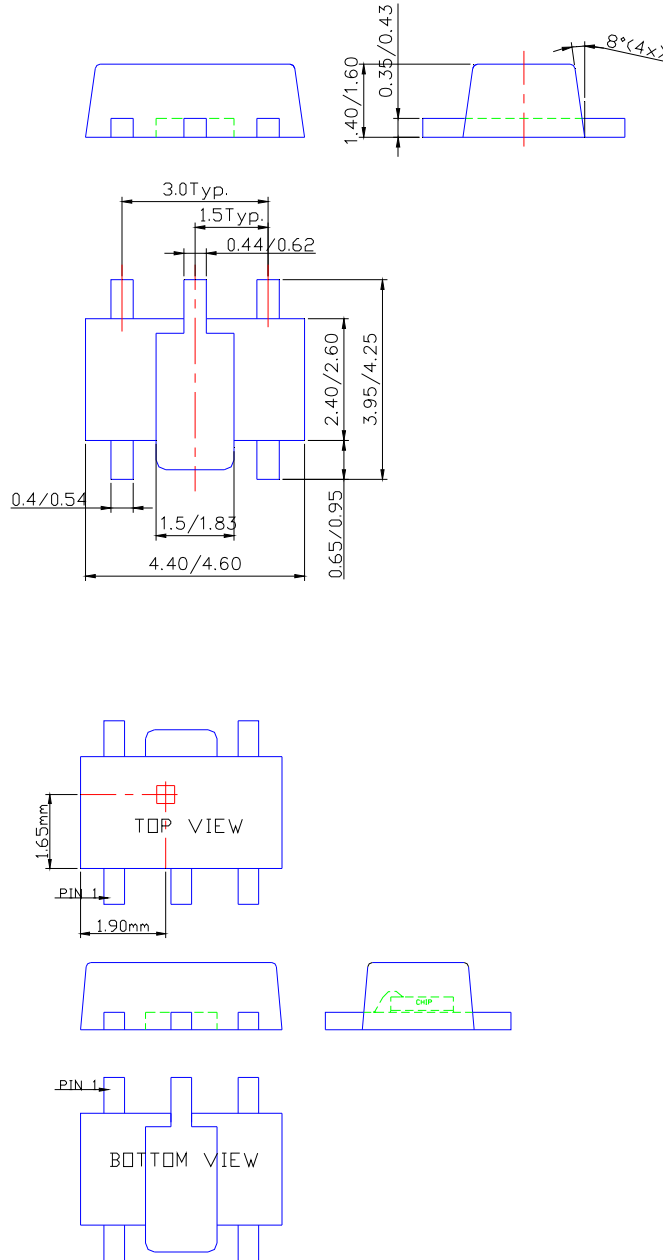

**Sensor Location**

**IMPORTANT NOTICE**

DIODES INCORPORATED MAKES NO WARRANTY OF ANY KIND, EXPRESS OR IMPLIED, WITH REGARDS TO THIS DOCUMENT, INCLUDING, BUT NOT LIMITED TO, THE IMPLIED WARRANTIES OF MERCHANTABILITY AND FITNESS FOR A PARTICULAR PURPOSE (AND THEIR EQUIVALENTS UNDER THE LAWS OF ANY JURISDICTION).

Diodes Incorporated and its subsidiaries reserve the right to make modifications, enhancements, improvements, corrections or other changes without further notice to this document and any product described herein. Diodes Incorporated does not assume any liability arising out of the application or use of this document or any product described herein; neither does Diodes Incorporated convey any license under its patent or trademark rights, nor the rights of others. Any Customer or user of this document or products described herein in such applications shall assume all risks of such use and will agree to hold Diodes Incorporated and all the companies whose products are represented on Diodes Incorporated website, harmless against all damages.

Diodes Incorporated does not warrant or accept any liability whatsoever in respect of any products purchased through unauthorized sales channel.

Should Customers purchase or use Diodes Incorporated products for any unintended or unauthorized application, Customers shall indemnify and hold Diodes Incorporated and its representatives harmless against all claims, damages, expenses, and attorney fees arising out of, directly or indirectly, any claim of personal injury or death associated with such unintended or unauthorized application.

Products described herein may be covered by one or more United States, international or foreign patents pending. Product names and markings noted herein may also be covered by one or more United States, international or foreign trademarks.

**LIFE SUPPORT**

Diodes Incorporated products are specifically not authorized for use as critical components in life support devices or systems without the express written approval of the Chief Executive Officer of Diodes Incorporated. As used herein:

- A. Life support devices or systems are devices or systems which:
1. are intended to implant into the body, or
  2. support or sustain life and whose failure to perform when properly used in accordance with instructions for use provided in the labeling can be reasonably expected to result in significant injury to the user.
- B. A critical component is any component in a life support device or system whose failure to perform can be reasonably expected to cause the failure of the life support device or to affect its safety or effectiveness.



Customers represent that they have all necessary expertise in the safety and regulatory ramifications of their life support devices or systems, and acknowledge and agree that they are solely responsible for all legal, regulatory and safety-related requirements concerning their products and any use of Diodes Incorporated products in such safety-critical, life support devices or systems, notwithstanding any devices- or systems-related information or support that may be provided by Diodes Incorporated. Further, Customers must fully indemnify Diodes Incorporated and its representatives against any damages arising out of the use of Diodes Incorporated products in such safety-critical, life support devices or systems.

Copyright © 2010, Diodes Incorporated

[www.diodes.com](http://www.diodes.com)

## Looking for pricing, stock, or lifecycle information?

Click below to explore more details on WIN SOURCE:

-  [View AH288-PL-B on WIN SOURCE](#)
-  [Diodes Incorporated Information](#)

## Optimize Your Supply Chain with WIN SOURCE Solutions

-  Global Sourcing Solution
-  Obsolete Management
-  Cost Control Management
-  Shortage Management
-  Alternative Solution
-  Excess Inventory Management