



**THE DATASHEET OF
IRS29831PBF**



LED FLYBACK CONTROL IC

Features

- Flyback LED Driver
- Integrated 700 V MOSFET
- Critical-conduction / Transition mode operation
- Primary constant power control
- Burst mode operation at light load
- Over-current protection
- Micro power startup (150 μ A)
- Low quiescent current (2.5 mA)
- Latch immunity and ESD protection
- Open load / Over voltage protection
- Compatible with Triac Dimmers
- High Power Factor / Low THD

Typical Applications

- LED Drivers

Product Summary

Topology	Flyback
Drain Source Voltage	700 V
Max Drain Current	0.65 A
Max Converter Power	25 W

Package



8-Lead DIP

Ordering Information

Base Part Number	Package Type	Standard Pack		Complete Part Number
		Form	Quantity	
IRS29831PBF	DIP8	Tube/Bulk	50	IRS29831PBF

Table of Contents	Page
Ordering Information	1
Description	3
Absolute Maximum Ratings	4
Recommended Operating Conditions	4
Electrical Characteristics	5
Functional Block Diagram	7
State Diagram	8
Input/Output Pin Equivalent Circuit Diagram	9
Lead Definitions	10
Lead Assignments	10
Application Information and Additional Details	11
Package Details	15
Part Marking Information	16
Qualification Information	17

Description

The IRS29831 is an integrated LED driver control IC and power MOSFET designed to drive Flyback and Buck-Boost converter based LED drivers. The IRS29831 includes primary side power regulation allowing a low cost isolated or non-isolated LED driver to be implemented without the need for an opto-isolator for a fixed LED load. The IRS29831 is also compatible with converters that include secondary feedback circuitry. Other features of the IRS29831 include a high voltage startup enabling VCC supply to be derived initially from the high voltage DC bus until the auxiliary Flyback inductor winding takes over for rapid startup. The IRS29831 typically operates in critical conduction (CrCM) with full protection against open and short circuit as well as inductor saturation. The IRS29831 may be used in single stage LED drivers with no DC bus smoothing capacitor enabling high power factor and low THD with minimal component count.

Typical Connection Diagram (non-dimming)

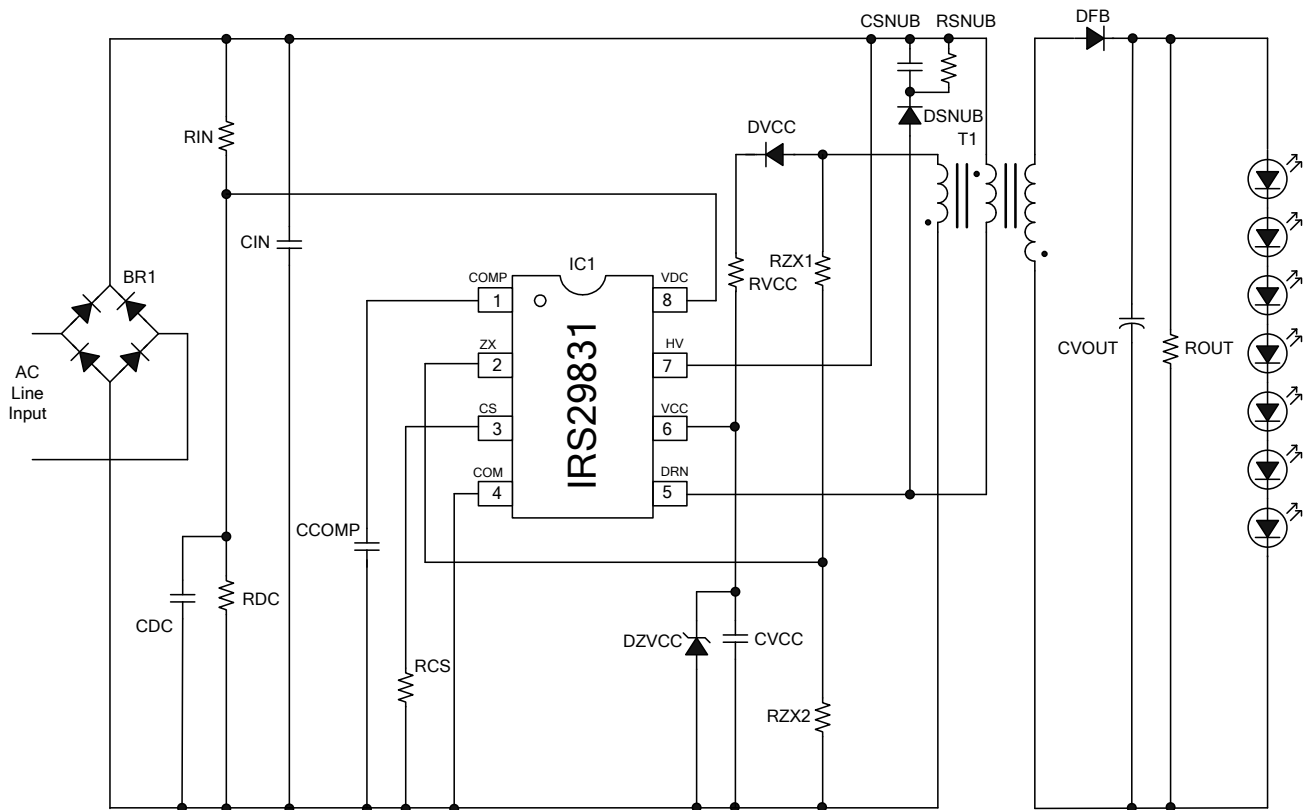

Absolute Maximum Ratings

Absolute maximum ratings indicate sustained limits beyond which damage to the device may occur. All voltage parameters are absolute voltages referenced to COM; all currents are defined positive into any lead. The thermal resistance and power dissipation ratings are measured under board mounted and still air conditions.

Symbol	Definition	Min.	Max.	Units	
V _{DS}	Drain-Source Voltage	---	700.0	V	
I _{DS}	Drain Current at 25°C [†]	---	0.65	A	
I _{DS}	Drain Current at 100°C [†]	---	0.4		
V _{CC}	IC Low Voltage Supply ^{††}	-0.3	20.8	V	
I _{CC}	VCC current	0	25.0	mA	
V _{HV}	HV Pin Voltage	-0.3	600	V	
I _{HV}	HV Pin Current	0	5.0	mA	
V _{DS}	Drain Pin Voltage	-0.3	700	V	
V _{COMP}	COMP Pin Voltage	-0.3	V _{CC} +0.3	V	
V _{DC}	VDC Pin Voltage				
V _{ZX}	ZX Pin Voltage				
V _{CS}	VCS Pin Voltage				
I _{COMP}	COMP Pin Current	-5	5	mA	
I _{DC}	VDC Pin Current				
I _{ZX}	ZX Pin Current				
I _{CS}	CS Pin Current				
P _D	Package Power Dissipation @ T _A ≤ +25°C P _D = (T _{JMAX} -T _A)/R _{θJA}	(8-Pin DIP)	---	1	W
R _{θJA}	Thermal Resistance, Junction to Ambient	(8-Pin DIP)	---	125	°C/W
T _J	Junction Temperature	-55	125	°C	
T _S	Storage Temperature	-55	125		
T _L	Lead Temperature (soldering, 10 seconds)	---	300		

Recommended Operating Conditions

For proper operation the device should be used within recommended conditions.

Symbol	Definition	Min.	Max.	Units
V _{CC}	Supply Voltage	V _{CCUV+}	18	V
I _{CC}	V _{CC} Supply Current	Note 2	10	mA
I _{CS}	CS Pin Current	-1	1	
I _{DC}	V _{DC} Pin Current			
I _{ZX}	ZX Pin Current			
I _{COMP}	COMP Pin Current	0	6.0	V
V _{DC}	V _{DC} Pin Voltage			
V _{CS}	V _{CS} Pin Voltage	0.1	2.0	
T _J	Junction Temperature	-25	100	°C

†: The MOSFET device used in this product is rated to 4A. It has been de-rated to conform to the thermal limits of the DIP8 package assuming no heat sink is attached.

††: This IC contains a zener clamp structure between the chip VCC and COM which has a nominal breakdown voltage of 20V. This supply pin should not be driven by a DC, low impedance power source greater than the VCLAMP specified in the Electrical Characteristics section.

Electrical Characteristics
 $V_{CC} = V_{BIAS} = 14V \pm 0.25V$, $C_{OUT} = 1000\mu F$,

 $V_{COMP} = V_{OC} = V_{DC} = V_{ZX} = 0V$, $T_A = 25^\circ C$ unless otherwise specified

Symbol	Definition	Min	Typ	Max	Units	Test Conditions
MOSFET Characteristics						
V_{DSMAX}	Maximum Drain-Source Voltage	700.0	---	---	V	
I_{DMAX}	Maximum Continuous Drain Current	---	---	0.65	A	
Source-Drain Diode Characteristics						
V_{SD}	Diode Forward Voltage	---	---	1.4	V	
T_{rr}	Reverse Recovery Time	---	437.0	---	ns	
Q_{rr}	Reverse Recovery Charge	---	2.2	---	μC	
Supply Characteristics						
V_{CCUV+}	V_{CC} Supply Under Voltage Positive Going Threshold	11.5	12.5	13.5	V	
V_{CCUV-}	V_{CC} Supply Under Voltage Negative Going Threshold	9.5	10.5	11.5		
V_{UVHYS}	V_{CC} Supply Under Voltage Lockout Hysteresis	1.5	2.0	3.0		
I_{QCCUV}	UVLO Mode V_{CC} Quiescent Current	---	150	---	μA	$V_{CC} = 6V$
I_{CC}	V_{CC} Supply Current	---	2.5	5.0	mA	
V_{CLAMP}	V_{CC} Zener Clamp Voltage	19.8	20.8	21.8	V	$I_{CC} = 10mA$
High Voltage Startup Characteristics						
$V_{HVS_{MIN}}$	Minimum Startup Voltage	30.0	---	---	V	
I_{HV_CHARGE}	V_{CC} Charge Current	1	2	---	mA	$V_{CC} < V_{CCUV-}$ HV=100V~400V
I_{HVS_OFF}	High Voltage Start-Up Circuit OFF State Leakage Current	---	---	50	μA	HV=400V
Error Amplifier Characteristics						
$I_{COMPSOURCE}$	COMP Pin Error Amplifier Output Current Sourcing	---	30	---	μA	
$I_{COMPSINK}$	COMP Pin Error Amplifier Output Current Sinking	---	30	---		
V_{COMPOH}	Error Amplifier Output Voltage Swing (high state)	---	13.5	---	V	
V_{COMPOL}	Error Amplifier Output Voltage Swing (low state)	---	2.5	---		GBD
$V_{COMPFLT}$	Error Amplifier Output Voltage in Fault Mode	---	0	---		
I_{VDC}	Input bias current	---	-1	--	μA	$V_{DC} = 0$ to 3V
Control Characteristics						
V_{ZX+}	ZX Pin Threshold Voltage (Arm)	1.40	1.54	1.68	V	
V_{ZX-}	ZX Pin Threshold Voltage (Trigger)	0.52	0.6	0.68		
V_{PREF}	Power Regulation Reference	---	1.00	---		
K_{MULT}	Multiplier Gain	1.90	2.00	2.10		$V_{CS} = 0.5V$
t_{BLANK}	OC pin current-sensing blank time	160	200	264	ns	$V_{DC} = 2.5V$ $COMP = 4.0V$ $CS = 1.5V$

Electrical Characteristics (cont'd)
 $V_{CC} = V_{BIAS} = 14V \pm 0.25V$, $C_{OUT} = 1000pF$,

 $V_{COMP} = V_{OC} = V_{DC} = V_{ZX} = 0V$, $T_A = 25^\circ C$ unless otherwise specified.

T_{WD}	PFC Watch-dog Pulse Interval	65	100	135	μs	ZX = 0 COMP = 4.0V
t_{ONMIN}	PWM Minimum ON time	220	280	340	ns	††
t_{ONMAX}	PWM Maximum ON Time	22	32	42	μs	ZX = 0 COMP = 13V ††
t_{OFFMIN}	PWM Minimum OFF Time	2.7	3.0	3.3		††
V_{DCMAX}	Maximum voltage for multiplier input [†]	---	---	7.0	V	GBD
$V_{CSPKMAX}$	Maximum peak voltage for multiplier input [†]	---	---	1.0	V	Signal is averaged before entering multiplier input. GBD
Protection Circuitry Characteristics						
V_{CSTH}	CS Pin Over-current Sense Threshold	1.19	1.25	1.31	V	
$V_{COMPOFF}$	Cut off voltage below which gate drive output is disabled	1.12	1.40	1.68		
$V_{COMPOFF_HYS}$	Cut off voltage hysteresis	---	40	---	mV	
V_{OVTH}	ZX Pin Over-voltage Comparator Threshold	4.90	5.15	5.40	V	
V_{OVHYS}	ZX Pin Over-voltage Comparator Hysteresis	---	200	---	mV	

[†]: Multiplier operates accurately from zero to the maximum input specified.

^{††}: Measured at the Drain with MOSFET switching delay also included.

GBD: Guaranteed by design.

Functional Block Diagram

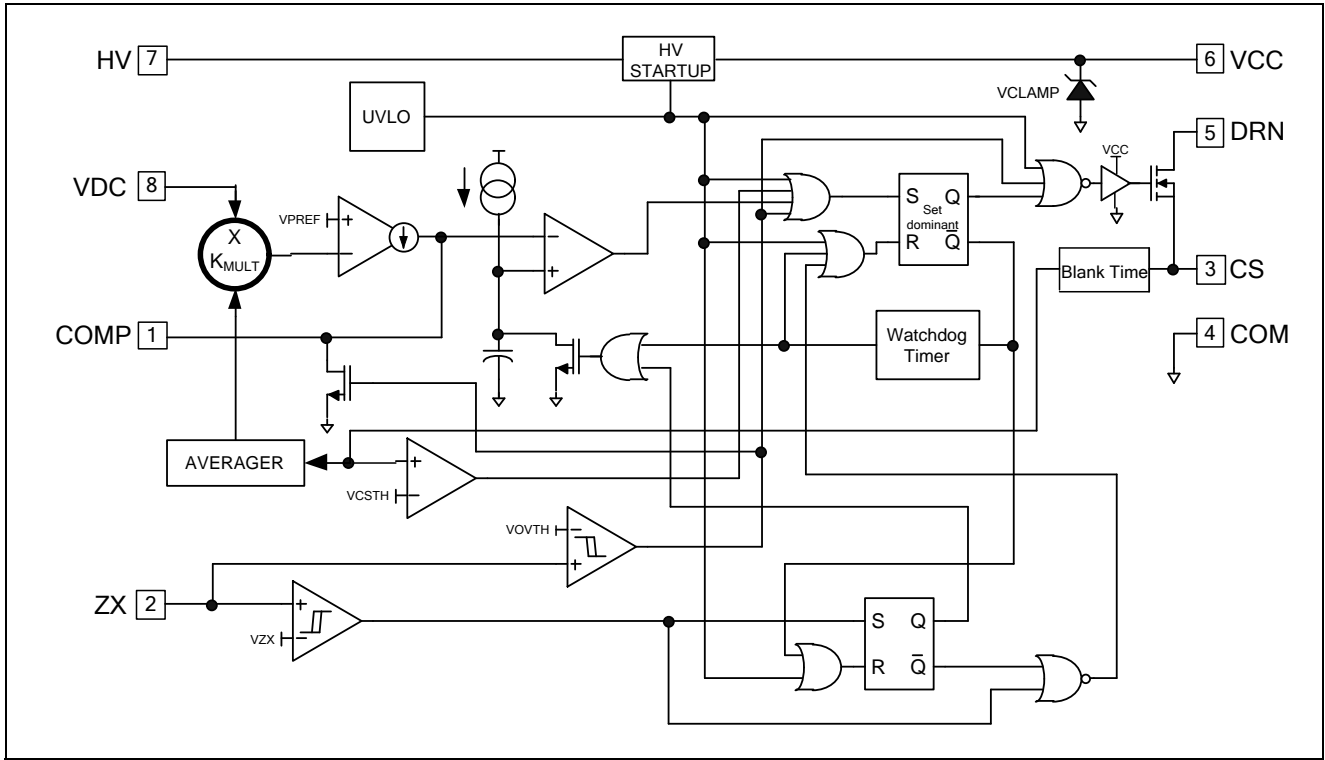

State Diagram

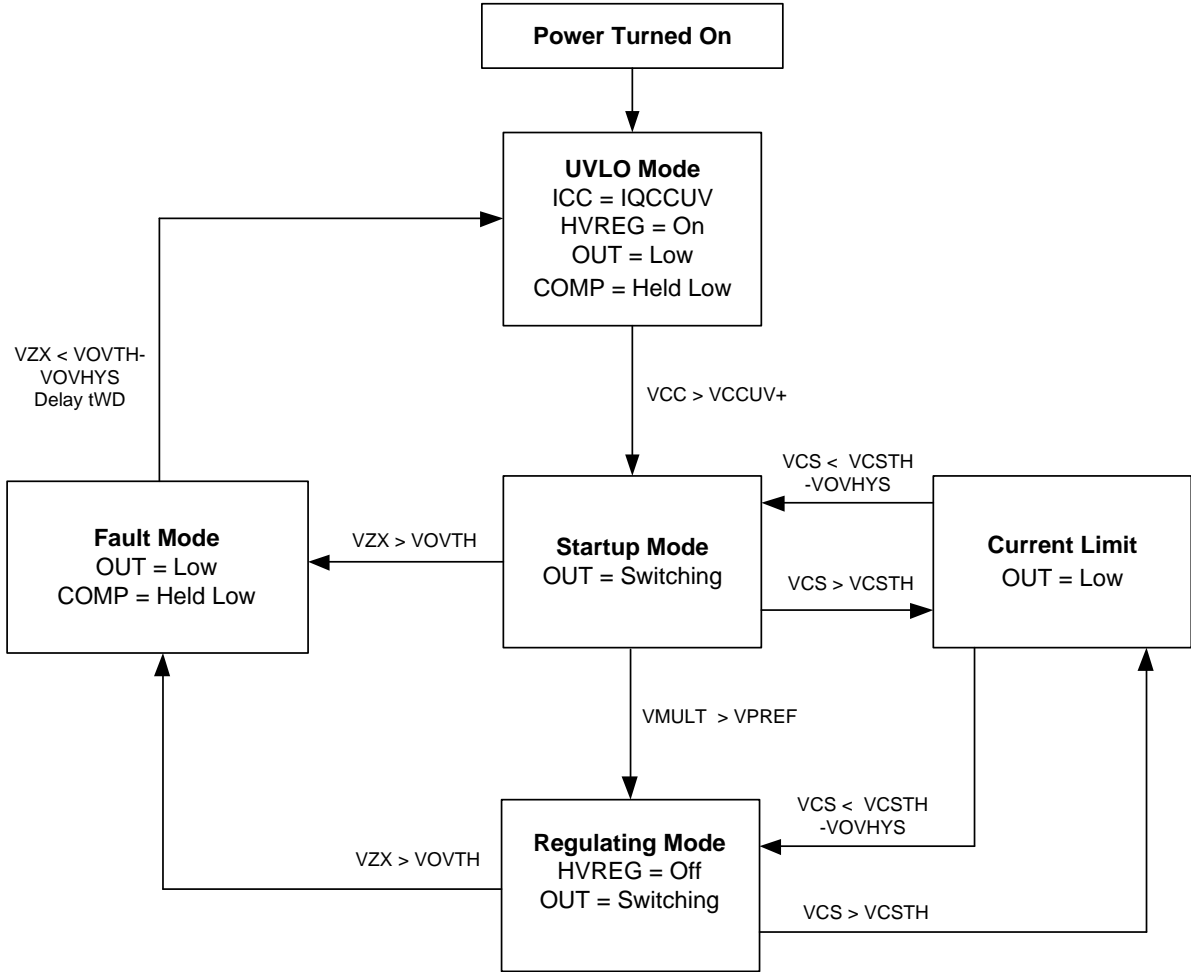

Input/Output Pin Equivalent Circuit Diagrams

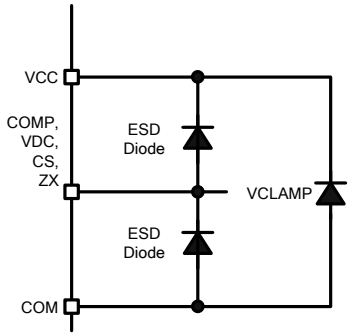

Lead Definitions

Symbol	Description
COMP	Compensation and averaging capacitor input
ZX	PFC Zero-Crossing & Over-Voltage Detection
CS	PFC Current Sensing Input
COM	IC Power & Signal Ground
DRN	MOSFET Drain
VCC	Logic & Low-Side Gate Driver Supply
HV	High Voltage Startup Input
VDC	DC Bus Voltage Input

Lead Assignments

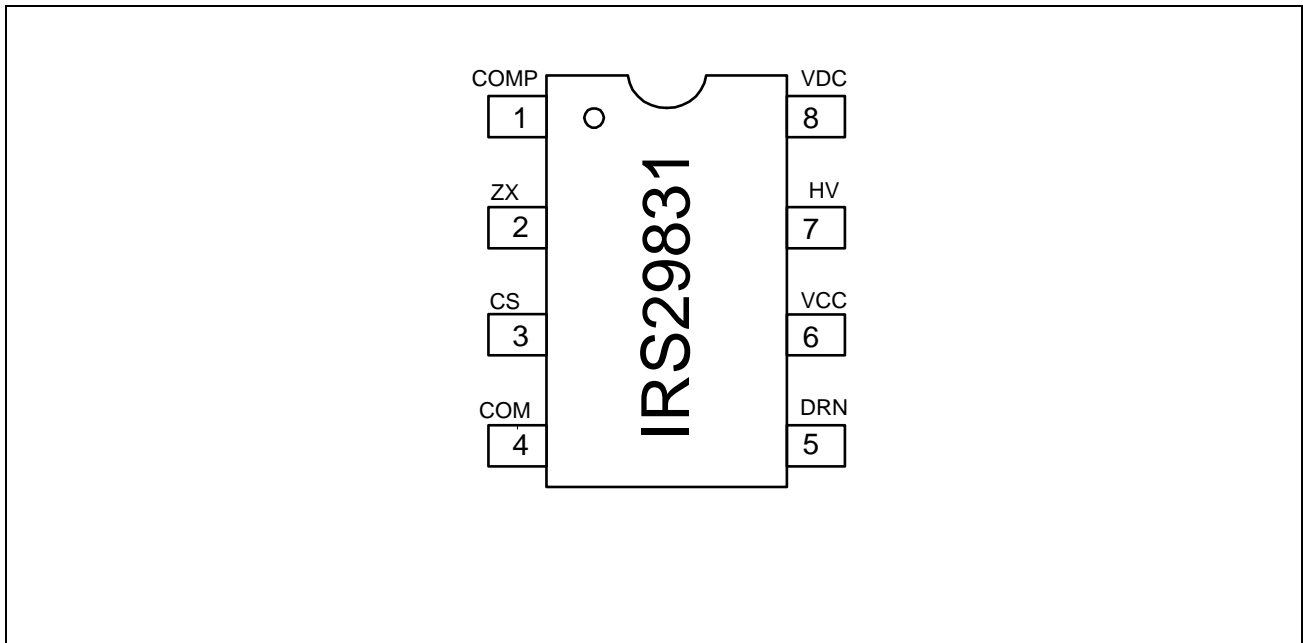

Application Information and Additional Details

The IRS29831 is a switched mode controller IC with an integrated high voltage MOSFET designed for use in Flyback and Buck-Boost converters. An internal high voltage regulator is included to supply the IC low voltage VCC supply allowing operation directly from a DC input voltage up to 600V with rapid startup at low and high AC line inputs.

Internal high voltage startup

In order to begin operating, the IRS29831 requires its VCC supply to be raised above the under voltage lockout positive threshold (VCCUV+) and to continue operating requires VCC to be maintained above the under voltage lockout negative threshold (VCCUV-).

The internal high voltage start up circuit provides the initial VCC voltage until an auxiliary winding from the converter transformer takes over. A series resistor RVCC and 18V zener clamp DZVCC or other voltage limiting scheme is necessary in line with VCC to prevent damage to the IRS29831 if the auxiliary winding voltage exceeds the internal clamp voltage (VCLAMP).

The HV regulator enables the IRS29831 based LED driver to start up very rapidly and deliver light within 0.5s of switch on at any line input voltage. When the converter reaches steady state and VCC can be supplied through the auxiliary winding the HV regulator switches off for zero power dissipation.

The IRS29831 is primarily targeted at LED driver applications up to 25W using isolated or non-isolated Flyback converter or Buck-Boost topologies. The auxiliary winding is also used to detect output voltage and zero-crossing point. In the event of a short circuit at the output, the VCC supply from the auxiliary winding collapses causing the IRS29831 to enter under voltage lockout and shut down. The startup sequence is then re-initialized continuing in “hiccup” mode until the short circuit is removed. Short circuit protection is therefore auto-recovering enabling the driver to tolerate the condition without damage to the components. A capacitor in the order of 10pF at the ZX may be required for correct operation.

Primary power regulation

To eliminate feedback circuitry and opto-isolators where the load consists of a fixed number of

LEDs, the IRS29831 is capable of regulating the output current indirectly by calculating and controlling the input power of the converter. Since an LED load has an approximately fixed voltage the power consumed is proportional to the current. In practice there are variations in LED forward voltage drop due to tolerance and temperature, however perfect accuracy is not usually required in such applications. For a fixed number of LEDs the current will be approximately proportional to the input power allowing output current regulation of +/-5% over line input from 120VAC to 230VAC. Power regulation has been shown to provide slightly less Lumen output variation than current regulation.

The IRS29831 senses input voltage and current then averages and multiplies these quantities to determine the input power. This is then regulated against an accurate fixed reference to control the LED current.

The line input voltage is sensed through a resistor divider (RIN and RDC) to provide a voltage within the range from 0V to VDCMAX. Primary current is sensed through shunt resistor (RCS) connected from the source of the Flyback MOSFET switch to the DC bus return. This waveform is a high frequency ramp rising from zero at the beginning of each switching cycle to reach a peak level at the point the MOSFET is switched off, remaining at zero during the off time.

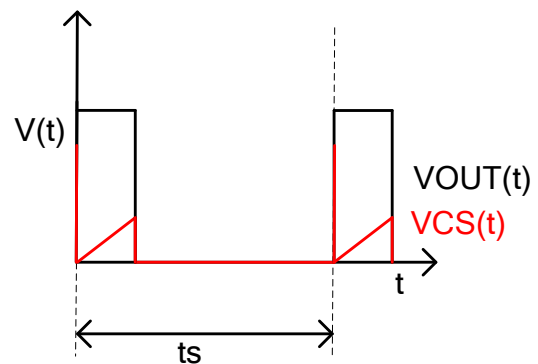

Figure 1: Current sense waveform

A transconductance error amplifier (OTA) uses an external capacitor (CCOMP) referenced to 0V to realize an integrator that provides a stable error voltage used to control the PWM on time. A response time of several AC line cycles is normally used as in typical power factor correction circuits to enable high power factor and low THD.

LED output current typically increases gradually as the input voltage is increased. At light loads the IRS29831 operates in burst mode to minimize losses and maintain a stable output when the COMP output voltage drops below the VCOMPOFF threshold.

Primary current limiting

At low line input voltages the power regulation loop demands a high peak current which can cause saturation of the primary inductor. In order to prevent this from occurring, the IRS29831 includes cycle by cycle primary current limiting with a fixed threshold VCSTH at the CS pin input. Under low line or fault conditions where the MOSFET current is abnormally high, the gate drive switches off as the current ramps up above VCSTH with a leading edge blanking period of tBLANK. Leading edge blanking avoids false tripping due to the fast high current switch on transient caused by parasitic capacitances in the internal MOSFET. This transient is also blanked from the averaging input that feeds the power regulation multiplier to prevent inaccuracies.

The IRS29831 normally operates in critical conduction mode (CrCM), also known as transition or boundary mode. The Flyback transformer auxiliary winding used to supply VCC is also used to provide the zero crossing or demagnetization signal to the IRS29831. This indicates when all of the energy stored in the inductor has been transferred to the output to trigger the next switching cycle.

The auxiliary winding voltage is divided through RZX1 and RZX2 to provide the ZX pin input signal.

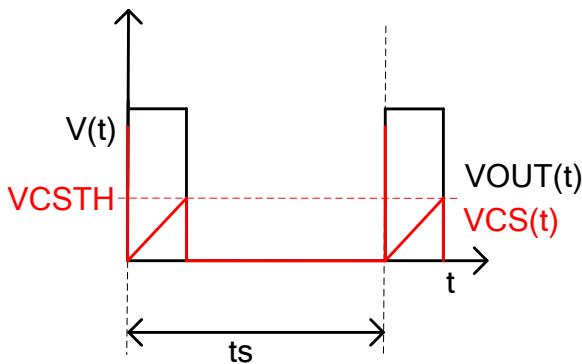

Figure 2: Cycle by cycle current limiting

The pulse appearing at ZX has an amplitude proportional to the secondary output voltage and therefore the DC output voltage:

$$V_{ZX} = \frac{N_A \cdot R_{ZX2} \cdot V_{OUT}}{N_S \cdot (R_{ZX1} + R_{ZX2})} \quad [1]$$

Where,

- N_A = Number of turns on the auxiliary winding
- N_S = Number of turns on the secondary winding
- V_{OUT} = DC Output Voltage (LED voltage)

When the IRS29831 integrated MOSFET switches off the voltage V_{ZX} transitions high. The values of R_{ZX1} and R_{ZX2} must be selected so that this voltage always exceeds the V_{ZX+} threshold.

It should be noted that if the IRS29831 is used in a converter that is required to drive loads with different numbers of LEDs with a range of voltage, an additional feedback circuit is needed to regulate the output current. In this case the V_{ZX} voltage needs to exceed V_{ZX+} at the minimum load voltage. If V_{ZX} does not exceed V_{ZX+} the IRS29831 will operate in discontinuous mode (DCM) with a fixed time of t_{WD} .

When the voltage at V_{ZX} exceeds V_{ZX+} the IRS29831 is armed. It then waits until V_{ZX} drops below V_{ZX-} again to trigger the next switching cycle.

The IRS29831 includes a minimum off time function so that if the ZX pin input transitions high and low before t_{OFFMIN} the gate drive output will not go high again until after this period. This prevents false tripping at the ZX input and also limits the maximum switching frequency of the converter by entering discontinuous mode (DCM) under conditions where the off time would otherwise be very short. This reduces switching losses and prevents transformer overheating.

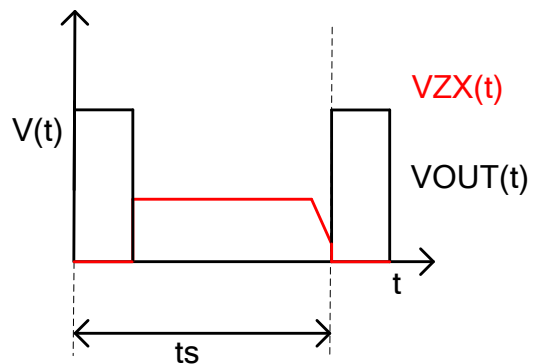

Figure 3: Zero crossing detection

Integrated MOSFET

The IRS29831 includes an internal 700V rated MOSFET with low $R_{DS(on)}$ to enable driver operation up to 25W with minimal temperature rise. A snubber network consisting of DSNUB, CSNUB and RSNUB is required in Flyback converters to limit the peak ringing transient. In a typical circuit with appropriate snubber values the transient will not exceed 650V at maximum line input.

Over voltage protection

The ZX input is also used for output over voltage protection. If the load becomes disconnected the output voltage could potentially rise very high damaging components as well as presenting an electric shock hazard. In order to protect against this the IRS29831 is able to detect the output voltage indirectly through the proportional ZX input. If the ZX input voltage exceeds $VOVTH$ when the MOSFET switches off, the gate drive switches off and remains off for a period of tWD before beginning the next cycle irrespective of when the ZX voltage transitions low. In this case the IRS29831 discharges the COMP capacitor so that the next cycle will begin at reduced duty cycle. When the open circuit is removed the converter recovers with a soft start. This protection scheme allows the LED load to be “hot” connected and disconnected from the converter output without risk of damaging the circuit or of high voltages appearing at the output. The overvoltage threshold is set by choosing the values of $RZX1$ and $RZX2$ appropriately, according to the formula:

$$VOUT_{OV} = \frac{VOVTH \cdot N_s \cdot (RZX1 + RZX2)}{N_A \cdot RZX2} \quad [2]$$

The recommended over voltage threshold is 20-25% above the normal operating voltage of the LED load. This is important since re-connecting an LED load with the output capacitor charged to a higher voltage causes a high current discharge that can cause severe damage to LEDs. A bleed resistor is also recommended to discharge the output capacitor.

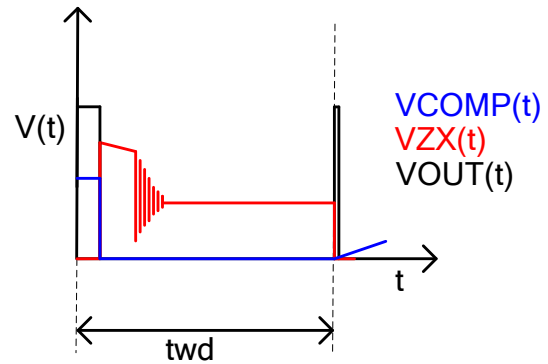

Figure 4: Overvoltage protection

Operating with a secondary feedback circuit

In applications where more accurate current regulation over a wide input and/or output voltage range required the IRS29831 can be used in conjunction with a secondary sensing and feedback circuit. This technique is also applied in designs where dimming to low levels is required for example in a 0-10V controlled dimmable LED driver. The feedback circuit can be fed through an opto-isolator or from the output of an operational amplifier if isolation is not required.

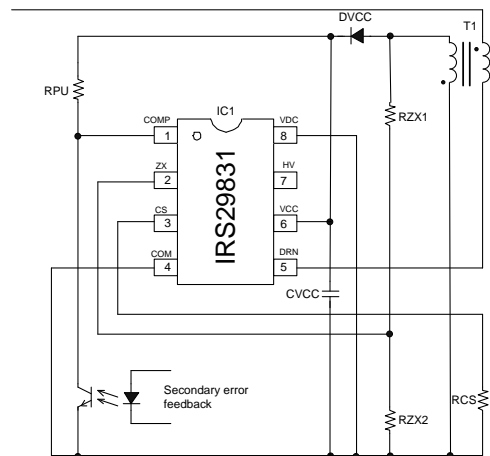

Figure 5: Secondary feedback circuit

A simple output voltage feedback scheme is shown in figure 5 to demonstrate how the opto-isolator can be connected to the IRS29831 to create a feedback circuit. The VDC input is tied to COM leaving the multiplier output at zero with the COMP output pulled up to maximum by the internal error amplifier. The opto-isolator feedback

pulls down on the COMP voltage to reduce the on time as the opto-diode current is increased driven by a secondary error amplifier circuit. A pull up resistor (RPU) may be added to improve stability.

Triac Dimming

A triac dimming LED driver can be easily implemented with the IRS29831 using a small number of additional components. The dimming design should be optimized to work in either the 120VAC or 220VAC range. It is not practical to create a design with good dimming performance and efficiency for both input voltages.

The dimming driver implementation consists of a single stage high power factor converter previously described with anti-ringing and active damping circuits added to the input to provide triac stability. The COMP output is also clamped to a maximum level by adding an external zener diode DZ3 referenced to COM. This prevents the primary side regulation circuit from attempting to compensate for the reduced AC input voltage detected during dimming. During dimming the converter operates with the on time determined by the voltage at which COMP is limited by the zener diode. A value of 6.8V typically provides good results for a 120VAC system. The schematic below shows a full implementation of a 120VAC triac dimmable LED driver.

RPD and CPD for the anti-ringing network to suppress high frequency oscillations that typically occur when the dimmer triac fires caused by the interaction of the dimmer with the LED driver input

filter. Typical values for RPD and CPD are 470Ohms (1W) and 100nF to 220nF (250V).

The active damping circuit based around a low voltage MOSFET MD is used to limit the inrush current when the triac fires. At the start of each line cycle the triac is in the off state and during this time MD is turned off while QD holds the gate low. This means that when the triac fires the series damping resistor RD limits the input current for a period of time until MD switches on. Zener diode DZ2 normally rated at 10V prevents MD from switching on due to residual leakage voltages that appear on the DC bus during the period before the triac fires. After the triac fires a voltage appears at DZ1 which is typically rated at 16V. This causes QD to switch off and CD to charge through RP1, RP2 and DD. After the delay determined by these components, MD switches on shorting out RD to remove the damping resistance when it is no longer necessary. Typical values for RP1, RP2 are 680K and CD is 4.7nF. DD can be a typical small diode such as a 1N4148.

The active circuit is designed to provide input resistance to damp the circuit at the firing point without incurring unnecessary power losses in the damping resistor RD. A typical value for RD is 100Ohms rated at 2W.

If some power loss can be tolerated in the interests of saving component cost RD can be reduced in value and MD and the components driving its gate can be removed. This low cost approach can still provide acceptable dimming performance with a small loss in converter efficiency.

Triac Dimmable LED Driver

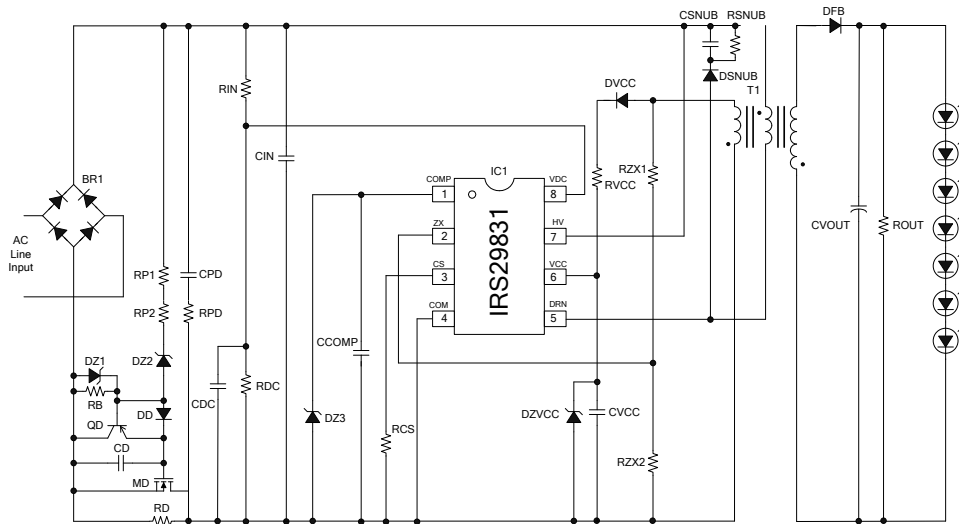

Package Details

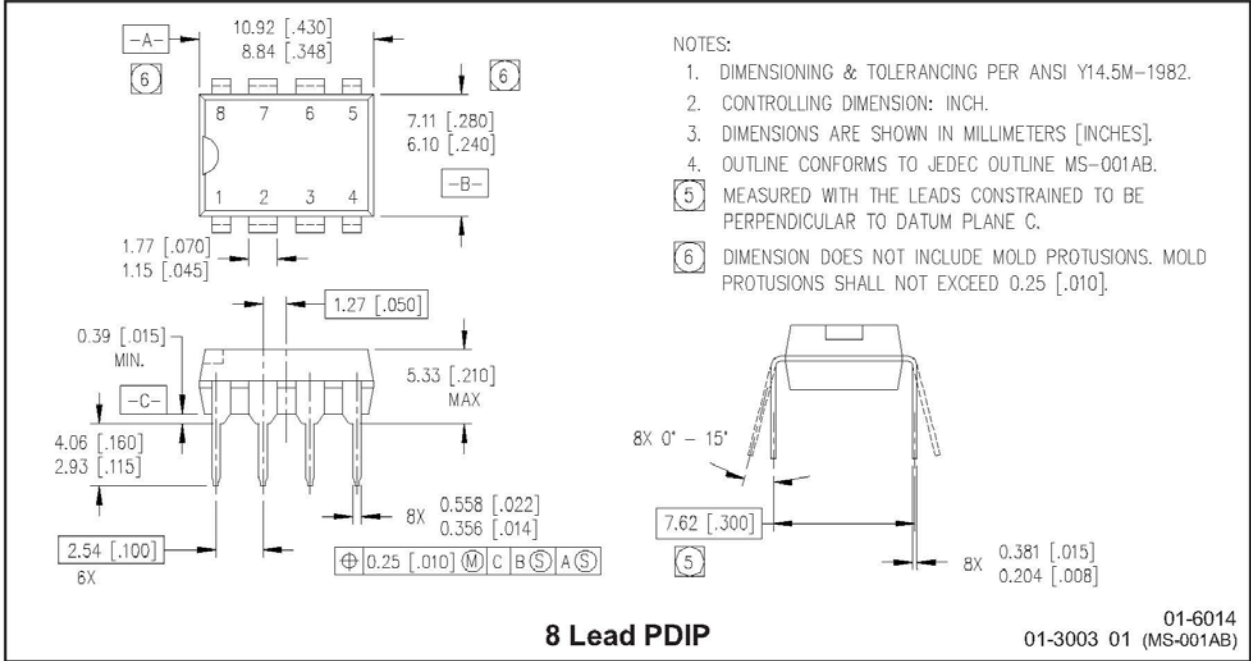

Part Marking Information

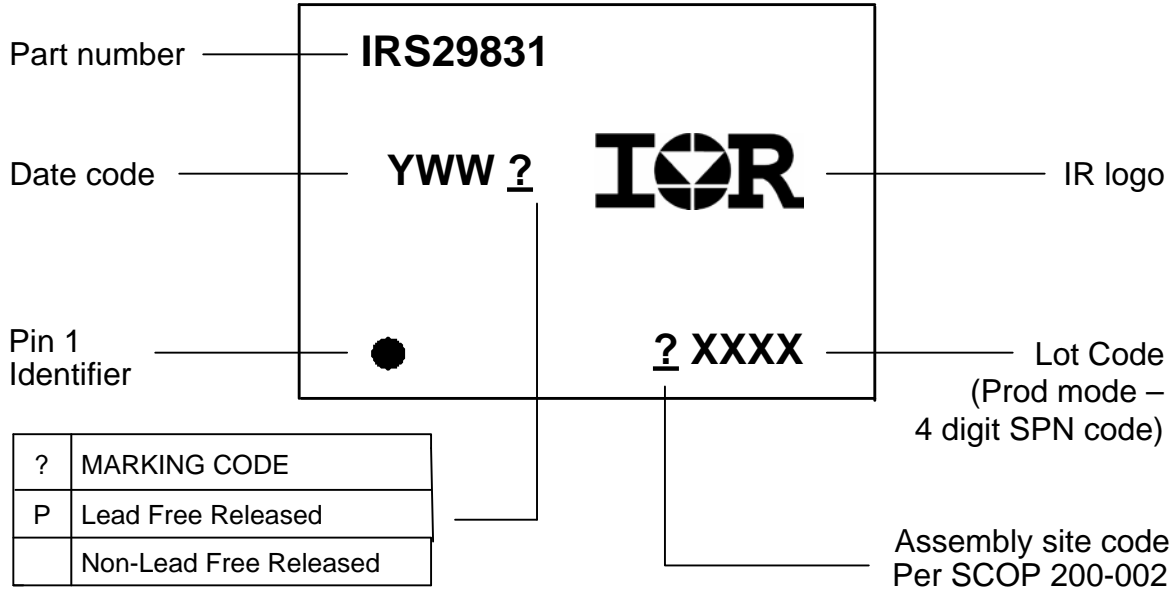

Qualification Information[†]

Qualification Level		Industrial ^{††}
		Comments: This family of ICs has passed JEDEC's Industrial qualification. IR's Consumer qualification level is granted by extension of the higher Industrial level.
ESD	Machine Model	Class B (per JEDEC standard JESD22-A115)
	Human Body Model	Class 1C (per ANSI/ESDA/JEDEC standard JS-001-2012)
IC Latch-Up Test		Class I, Level A (per JESD78)
RoHS Compliant		Yes

† Qualification standards can be found at International Rectifier's web site <http://www.irf.com/>

†† Higher qualification ratings may be available should the user have such requirements. Please contact your International Rectifier sales representative for further information.

††† Higher MSL ratings may be available for the specific package types listed here. Please contact your International Rectifier sales representative for further information.

The information provided in this document is believed to be accurate and reliable. However, International Rectifier assumes no responsibility for the consequences of the use of this information. International Rectifier assumes no responsibility for any infringement of patents or of other rights of third parties which may result from the use of this information. No license is granted by implication or otherwise under any patent or patent rights of International Rectifier. The specifications mentioned in this document are subject to change without notice. This document supersedes and replaces all information previously supplied.

For technical support, please contact IR's Technical Assistance Center
<http://www.irf.com/technical-info/>

WORLD HEADQUARTERS:
 233 Kansas St., El Segundo, California 90245
 Tel: (310) 252-7105

Looking for pricing, stock, or lifecycle information?

Click below to explore more details on WIN SOURCE:

 [View IRS29831PBF on WIN SOURCE](#)

 [Infineon Technologies](#) Information

Optimize Your Supply Chain with WIN SOURCE Solutions

-  Global Sourcing Solution
-  Obsolete Management
-  Cost Control Management
-  Shortage Management
-  Alternative Solution
-  Excess Inventory Management