

Features

- Frequency Receiving Range of (3 Versions)
 - $f_0 = 312.5$ MHz to 317.5 MHz or
 - $f_0 = 431.5$ MHz to 436.5 MHz or
 - $f_0 = 868$ MHz to 870 MHz
- 30 dB Image Rejection
- Receiving Bandwidth
 - $B_{IF} = 300$ kHz for 315 MHz/433 MHz Version
 - $B_{IF} = 600$ kHz for 868 MHz Version
- Fully Integrated LC-VCO and PLL Loop Filter
- Very High Sensitivity with Power Matched LNA
 - ATA5723/ATA5724:
 - 107 dBm, FSK, BR_0 (1.0 kBit/s to 1.8 kBit/s), Manchester, BER 10E-3
 - 113 dBm, ASK, BR_0 (1.0 kBit/s to 1.8 kBit/s), Manchester, BER 10E-3
 - ATA5728:
 - 105 dBm, FSK, BR_0 (1.0 kBit/s to 1.8 kBit/s), Manchester, BER 10E-3
 - 111 dBm, ASK, BR_0 (1.0 kBit/s to 1.8 kBit/s), Manchester, BER 10E-3
- High System IIP3
 - -18 dBm at 868 MHz
 - -23 dBm at 433 MHz
 - -24 dBm at 315 MHz
- System 1-dB Compression Point
 - -27.7 dBm at 868 MHz
 - -32.7 dBm at 433 MHz
 - -33.7 dBm at 315 MHz
- High Large-signal Capability at GSM Band (Blocking -33 dBm at +10 MHz, IIP3 = -24 dBm at +20 MHz)
- Logarithmic RSSI Output
- XTO Start-up with Negative Resistor of 1.5 k Ω
- 5V to 20V Automotive Compatible Data Interface
- Data Clock Available for Manchester and Bi-phase-coded Signals
- Programmable Digital Noise Suppression
- Low Power Consumption Due to Configurable Polling
- Temperature Range -40°C to +105°C
- ESD Protection 2 kV HBM, All Pins
- Communication to Microcontroller Possible using a Single Bi-directional Data Line
- Low-cost Solution Due to High Integration Level with Minimum External Circuitry Requirements
- Supply Voltage Range 4.5V to 5.5V

Benefits

- Low BOM List Due to High Integration
- Use of Low-cost 13 MHz Crystal
- Lowest Average Current Consumption for Application Due to Self Polling Feature
- Reuse of ATA5743 Software
- World-wide Coverage with One PCB Due to 3 Versions are Pin Compatible



UHF ASK/FSK Receiver

ATA5723
ATA5724
ATA5728



2. Pin Configuration

Figure 2-1. Pinning SSO20

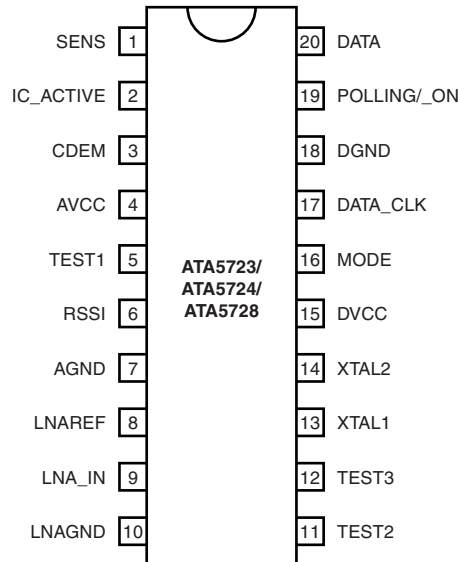

Table 2-1. Pin Description

Pin	Symbol	Function
1	SENS	Sensitivity-control resistor
2	IC_ACTIVE	IC condition indicator: Low = sleep mode, High = active mode
3	CDEM	Lower cut-off frequency data filter
4	AVCC	Analog power supply
5	TEST 1	Test pin, during operation at GND
6	RSSI	RSSI output
7	AGND	Analog ground
8	LNAREF	High-frequency reference node LNA and mixer
9	LNA_IN	RF input
10	LNAGND	DC ground LNA and mixer
11	TEST 2	Do not connect during operating
12	TEST 3	Test pin, during operation at GND
13	XTAL1	Crystal oscillator XTAL connection 1
14	XTAL2	Crystal oscillator XTAL connection 2
15	DVCC	Digital power supply
16	MODE	Selecting 315 MHz/other versions Low: 315 MHz version (ATA5723) High: 433 MHz/868 MHz versions (ATA5724/ATA5728)
17	DATA_CLK	Bit clock of data stream
18	DGND	Digital ground
19	POLLING/_ON	Selects polling or receiving mode; Low: receiving mode, High: polling mode
20	DATA	Data output/configuration input

3. RF Front-end

The RF front-end of the receiver is a low-IF heterodyne configuration that converts the input signal into about 1 MHz IF signal with a typical image rejection of 30 dB. According to Figure 1-2 on page 3 the front-end consists of an LNA (Low Noise Amplifier), LO (Local Oscillator), I/Q mixer, polyphase low-pass filter and an IF amplifier.

The PLL generates the drive frequency f_{LO} for the mixer using a fully integrated synthesizer with integrated low noise LC-VCO (Voltage Controlled Oscillator) and PLL-loop filter. The XTO (crystal oscillator) generates the reference frequency $f_{REF} = f_{XTO}/2$ (868 MHz and 433 MHz versions) or $f_{REF} = f_{XTO}/3$ (315 MHz version). The integrated LC-VCO generates two or four times the mixer drive frequency f_{VCO} . The I/Q signals for the mixer are generated with a divide by two or four circuit ($f_{LO} = f_{VCO}/2$ for 868 MHz version, $f_{LO} = f_{VCO}/4$ for 433 MHz and 315 MHz versions). f_{VCO} is divided by a factor of 128 or 64 and feeds into a phase frequency detector and is compared with f_{REF} . The output of the phase frequency detector is fed into an integrated loop filter and thereby generates the control voltage for the VCO. If f_{LO} is determined, f_{XTO} can be calculated using the following formula:

$f_{REF} = f_{LO}/128$ for 868 MHz band, $f_{REF} = f_{LO}/64$ for 433 MHz bands, $f_{REF} = f_{LO}/64$ for 315 MHz bands.

The XTO is a two-pin oscillator that operates at the series resonance of the quartz crystal with high current but low voltage signal, so that there is only a small voltage at the crystal oscillator frequency at pins XTAL1 and XTAL2. According to Figure 3-1, the crystal should be connected to GND with two capacitors C_{L1} and C_{L2} from XTAL1 and XTAL2 respectively. The value of these capacitors are recommended by the crystal supplier. Due to an inductive impedance at steady state oscillation and some PCB parasitics, a lower value of C_{L1} and C_{L2} is normally necessary.

The value of C_{Lx} should be optimized for the individual board layout to achieve the exact value of f_{XTO} and hence of f_{LO} . (The best way is to use a crystal with known load resonance frequency to find the right value for this capacitor.) When designing the system in terms of receiving bandwidth and local oscillator accuracy, the accuracy of the crystal and the XTO must be considered.

Figure 3-1. XTO Peripherals

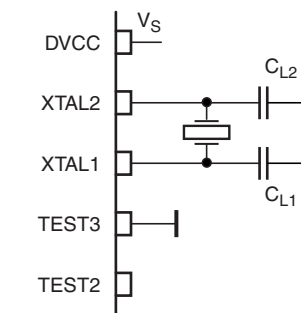

The nominal frequency f_{LO} is determined by the RF input frequency f_{RF} and the IF frequency f_{IF} using the following formula (low-side injection):

$$f_{LO} = f_{RF} - f_{IF}$$

To determine f_{LO} , the construction of the IF filter must be considered. The nominal IF frequency is $f_{IF} = 950$ kHz. To achieve a good accuracy of the filter corner frequencies, the filter is tuned by the crystal frequency f_{XTO} . This means that there is a fixed relationship between f_{IF} and f_{LO} .

$$f_{IF} = f_{LO}/318 \text{ for the 315 MHz band (ATA5723)}$$

$$f_{IF} = f_{LO}/438 \text{ for the 433.92 MHz band (ATA5724)}$$

$$f_{IF} = f_{LO}/915 \text{ for the 868.3 MHz band (ATA5728)}$$

The relationship is designed to achieve the nominal IF frequency of:

$$f_{IF} = 987 \text{ kHz for the 315 MHz and } B_{IF} = 300 \text{ kHz (ATA5723)}$$

$$f_{IF} = 987 \text{ kHz for the 433.92 MHz and } B_{IF} = 300 \text{ kHz (ATA5724)}$$

$$f_{IF} = 947.8 \text{ kHz for the 868.3 MHz and } B_{IF} = 600 \text{ kHz (ATA5728)}$$

The RF input either from an antenna or from an RF generator must be transformed to the RF input pin LNA_IN. The input impedance of this pin is provided in the electrical parameters. The parasitic board inductances and capacitances influence the input matching. The RF receiver ATA5723/ATA5724/ATA5728 exhibits its highest sensitivity if the LNA is power matched. Because of this, matching to a SAW filter, a 50Ω or an antenna is easier.

Figure 14-1 on page 32 “Application Circuit” shows a typical input matching network for $f_{RF} = 315$ MHz, $f_{RF} = 433.92$ MHz or $f_{RF} = 868.3$ MHz to 50Ω. The input matching network shown in Table 14-2 on page 32 is the reference network for the parameters given in the electrical characteristics.

4. Analog Signal Processing

4.1 IF Filter

The signals coming from the RF front-end are filtered by the fully integrated 4th-order IF filter. The IF center frequency is:

$$f_{IF} = 987 \text{ kHz for the 315 MHz and } B_{IF} = 300 \text{ kHz (ATA5723)}$$

$$f_{IF} = 987 \text{ kHz for the 433.92 MHz and } B_{IF} = 300 \text{ kHz (ATA5724)}$$

$$f_{IF} = 947.9 \text{ kHz for the 868.3 MHz and } B_{IF} = 600 \text{ kHz (ATA5728)}$$

The nominal bandwidth is 300 kHz for ATA5723 and ATA5724 and 600 kHz for ATA5728.

4.2 Limiting RSSI Amplifier

The subsequent RSSI amplifier enhances the output signal of the IF amplifier before it is fed into the demodulator. The dynamic range of this amplifier is $\Delta R_{RSSI} = 60$ dB. If the RSSI amplifier is operated within its linear range, the best S/N ratio is maintained in ASK mode. If the dynamic range is exceeded by the transmitter signal, the S/N ratio is defined by the ratio of the maximum RSSI output voltage and the RSSI output voltage due to a disturber. The dynamic range of the RSSI amplifier is exceeded if the RF input signal is approximately 60 dB higher compared to the RF input signal at full sensitivity.

The S/N ratio is not affected by the dynamic range of the RSSI amplifier in FSK mode because only the hard limited signal from a high-gain limiting amplifier is used by the demodulator.

The output voltage of the RSSI amplifier (VRSSI) is available at pin RSSI. Using the RSSI output signal, the signal strength of different transmitters can be distinguished. The usable input power range P_{Ref} is -100 dBm to -55 dBm.

Figure 4-1. RSSI Characteristics ATA5724

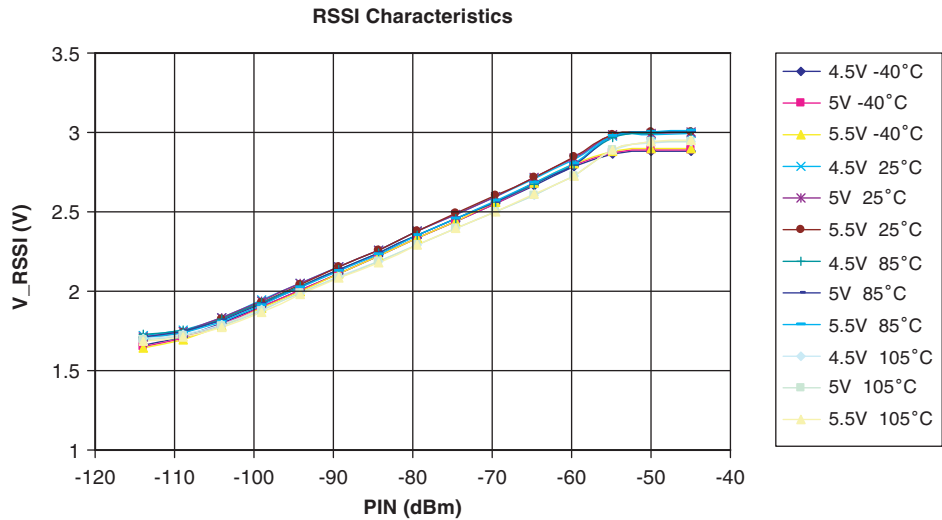

The output voltage of the RSSI amplifier is internally compared to a threshold voltage V_{Th_red} . V_{Th_red} is determined by the value of the external resistor R_{Sens} . R_{Sens} is connected between pin SENS and GND or V_S . The output of the comparator is fed into the digital control logic. By this means, it is possible to operate the receiver at a lower sensitivity.

If R_{Sens} is connected to GND, the receiver switches to full sensitivity. It is also possible to connect the pin SENS directly to GND to get the maximum sensitivity.

If R_{Sens} is connected to V_S , the receiver operates at a lower sensitivity. The reduced sensitivity is defined by the value of R_{Sens} , and the maximum sensitivity is defined by the signal-to-noise ratio of the LNA input. The reduced sensitivity depends on the signal strength at the output of the RSSI amplifier.

Since different RF input networks may exhibit slightly different values for the LNA gain, the sensitivity values given in the electrical characteristics refer to a specific input matching. This matching is described and illustrated in [Section 14. "Data Interface" on page 32](#).

R_{Sens} can be connected to V_S or GND using a microcontroller. The receiver can be switched from full sensitivity to reduced sensitivity or vice versa at any time. In polling mode, the receiver does not wake up if the RF input signal does not exceed the selected sensitivity. If the receiver is already active, the data stream at pin DATA disappears when the input signal is lower than defined by the reduced sensitivity. Instead of the data stream, the pattern according to [Figure 4-2 "Steady L State Limited DATA Output Pattern"](#) is issued at pin DATA to indicate that the receiver is still active (see [Figure 13-2 on page 30 "Data Interface"](#)).

Figure 4-2. Steady L State Limited DATA Output Pattern



4.3 FSK/ASK Demodulator and Data Filter

The signal coming from the RSSI amplifier is converted into the raw data signal by the ASK/FSK demodulator. The operating mode of the demodulator is set using the bit ASK/_FSK in the OPMODE register. Logic L sets the demodulator to FSK, applying H to ASK mode.

In ASK mode an automatic threshold control circuit (ATC) is employed to set the detection reference voltage to a value where a good signal to noise ratio is achieved. This circuit also implements the effective suppression of any kind of in-band noise signals or competing transmitters. If the S/N (ratio to suppress in-band noise signals) exceeds about 10 dB the data signal can be detected properly. However, better values are found for many modulation schemes of the competing transmitter.

The FSK demodulator is intended to be used for an FSK deviation of 10 kHz $\leq \Delta f \leq$ 100 kHz. The data signal in FSK mode can be detected if the S/N (ratio to suppress in-band noise signals) exceeds about 2 dB. This value is valid for all modulation schemes of a disturber signal.

The output signal of the demodulator is filtered by the data filter before it is fed into the digital signal processing circuit. The data filter improves the S/N ratio as its pass-band can be adopted to the characteristics of the data signal. The data filter consists of a 1st order high-pass and a 2nd order low-pass filter.

The high-pass filter cut-off frequency is defined by an external capacitor connected to pin CDEM. The cut-off frequency of the high-pass filter is defined by the following formula:

$$f_{cu_DF} = \frac{1}{2 \times \pi \times 30 \text{ k}\Omega \times CDEM}$$

In self-polling mode the data filter must settle very rapidly to achieve a low current consumption. Therefore, CDEM cannot be increased to very high values if self-polling is used. On the other hand, CDEM must be large enough to meet the data filter requirements according to the data signal. Recommended values for CDEM are given in the electrical characteristics.

The cut-off frequency of the low-pass filter is defined by the selected baud-rate range (BR_Range). The BR_Range is defined in the OPMODE register (refer to [Section 11. "Configuring the Receiver" on page 25](#)). The BR_Range must be set in accordance to the baud-rate used.

The ATA5723/ATA5724/ATA5728 is designed to operate with data coding where the DC level of the data signal is 50%. This is valid for Manchester and Bi-phase coding. If other modulation schemes are used, the DC level should always remain within the range of $V_{DC_min} = 33\%$ and $V_{DC_max} = 66\%$. The sensitivity may be reduced by up to 2 dB in that condition.

Each BR_Range is also defined by a minimum and a maximum edge-to-edge time (t_{ee_sig}). These limits are defined in the electrical characteristics. They should not be exceeded to maintain full sensitivity of the receiver.

5. Receiving Characteristics

The RF receiver ATA5723/ATA5724/ATA5728 can be operated with and without a SAW front-end filter. In a typical automotive application, a SAW filter is used to achieve better selectivity and large signal capability. The receiving frequency response without a SAW front-end filter is illustrated in Figure 5-1 “Narrow Band Receiving Frequency Response ATA5724”. This example relates to ASK mode. FSK mode exhibits a similar behavior. The plots are printed relatively to the maximum sensitivity. If a SAW filter is used, an insertion loss of about 3 dB must be considered, but the overall selectivity is much better.

When designing the system in terms of receiving bandwidth, the LO deviation must be considered as it also determines the IF center frequency. The total LO deviation is calculated, to be the sum of the deviation of the crystal and the XTO deviation of the ATA5723/ATA5724/ATA5728. Low-cost crystals are specified to be within ± 90 ppm over tolerance, temperature, and aging. The XTO deviation of the ATA5723/ATA5724/ATA5728 is an additional deviation due to the XTO circuit. This deviation is specified to be ± 10 ppm worst case for a crystal with $CM = 7$ fF. If a crystal of ± 90 ppm is used, the total deviation is ± 100 ppm in that case. Note that the receiving bandwidth and the IF-filter bandwidth are equivalent in ASK mode but not in FSK mode.

Figure 5-1. Narrow Band Receiving Frequency Response ATA5724

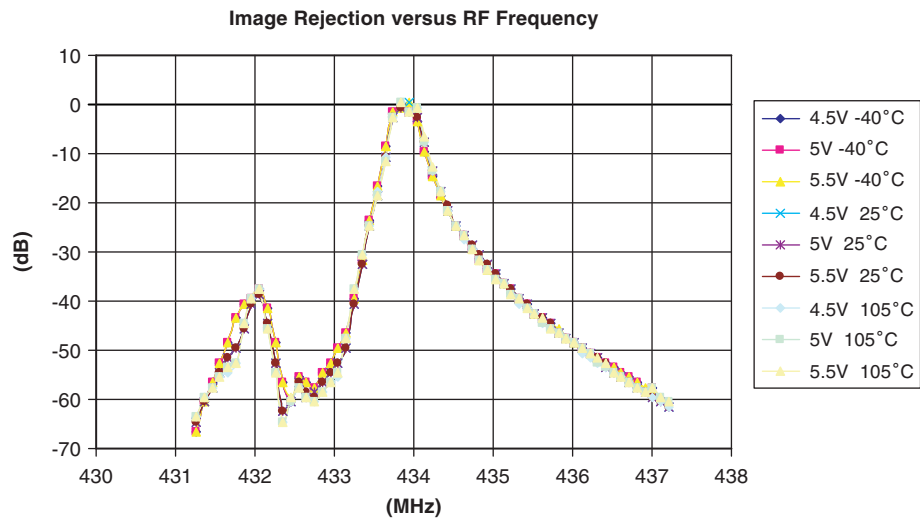

6. Polling Circuit and Control Logic

The receiver is designed to consume less than 1 mA while being sensitive to signals from a corresponding transmitter. This is achieved using the polling circuit. This circuit enables the signal path periodically for a short time. During this time the bit-check logic verifies the presence of a valid transmitter signal. Only if a valid signal is detected, the receiver remains active and transfers the data to the connected microcontroller. If there is no valid signal present, the receiver is in sleep mode most of the time resulting in low current consumption. This condition is called polling mode. A connected microcontroller is disabled during that time.

All relevant parameters of the polling logic can be configured by the connected microcontroller. This flexibility enables the user to meet the specifications in terms of current consumption, system response time, data rate etc.

The receiver is very flexible with regards to the number of connection wires to the microcontroller. It can be either operated by a single bi-directional line to save ports to the connected microcontroller or it can be operated by up to five uni-directional ports.

7. Basic Clock Cycle of the Digital Circuitry

The complete timing of the digital circuitry and the analog filtering is derived from one clock. This clock cycle T_{Clk} is derived from the crystal oscillator (XTO) in combination with a divide by 28 or 30 circuit. According to [Section 3. “RF Front-end” on page 5](#), the frequency of the crystal oscillator (f_{XTO}) is defined by the RF input signal (f_{RFIn}) which also defines the operating frequency of the local oscillator (f_{LO}). The basic clock cycle for ATA5724 and ATA5728 is $T_{\text{Clk}} = 28/f_{\text{XTO}}$ giving $T_{\text{Clk}} = 2.066 \mu\text{s}$ for $f_{\text{RF}} = 868.3 \text{ MHz}$ and $T_{\text{Clk}} = 2.069 \mu\text{s}$ for $f_{\text{RF}} = 433.92 \text{ MHz}$. For ATA5723 the basic clock cycle is $T_{\text{Clk}} = 30/f_{\text{REF}}$ giving $T_{\text{Clk}} = 2.0382 \mu\text{s}$ for $f_{\text{RF}} = 315 \text{ MHz}$.

T_{Clk} controls the following application-relevant parameters:

- Timing of the polling circuit including bit check
- Timing of the analog and digital signal processing
- Timing of the register programming
- Frequency of the reset marker
- IF filter center frequency (fIF0)

Most applications are dominated by three transmission frequencies: $f_{\text{Transmit}} = 315 \text{ MHz}$ is mainly used in USA, $f_{\text{Transmit}} = 868.3 \text{ MHz}$ and 433.92 MHz in Europe. All timings are based on T_{Clk} . For the aforementioned frequencies, T_{Clk} is given as:

- Application 315 MHz band ($f_{\text{XTO}} = 14.71875 \text{ MHz}$, $f_{\text{LO}} = 314.13 \text{ MHz}$, $T_{\text{Clk}} = 2.0382 \mu\text{s}$)
- Application 868.3 MHz band ($f_{\text{XTO}} = 13.55234 \text{ MHz}$, $f_{\text{LO}} = 867.35 \text{ MHz}$, $T_{\text{Clk}} = 2.066 \mu\text{s}$)
- Application 433.92 MHz band ($f_{\text{XTO}} = 13.52875 \text{ MHz}$, $f_{\text{LO}} = 432.93 \text{ MHz}$, $T_{\text{Clk}} = 2.0696 \mu\text{s}$)

For calculation of T_{Clk} for applications using other frequency bands, see table in [Section 18. “Electrical Characteristics ATA5724, ATA5728” on page 37](#).

The clock cycle of some function blocks depends on the selected baud-rate range (BR_Range), which is defined in the OPMODE register. This clock cycle T_{XCik} is defined by the following formulas:

BR_Range =	BR_Range0:	$T_{XCik} = 8 \times T_{Cik}$
	BR_Range1:	$T_{XCik} = 4 \times T_{Cik}$
	BR_Range2:	$T_{XCik} = 2 \times T_{Cik}$
	BR_Range3:	$T_{XCik} = 1 \times T_{Cik}$

8. Polling Mode

According to [Figure 8-1 on page 12](#), the receiver stays in polling mode in a continuous cycle of three different modes. In sleep mode the signal processing circuitry is disabled for the time period T_{Sleep} while consuming low current of $I_S = I_{Soff}$. During the start-up period, $T_{Startup}$, all signal processing circuits are enabled and settled. In the following bit-check mode, the incoming data stream is analyzed bit-by-bit and compared with a valid transmitter signal. If no valid signal is present, the receiver is set back to sleep mode after the period $T_{Bit-check}$. This period varies according to each check as it is a statistical process. An average value for $T_{Bitcheck}$ is given in the electrical characteristics. During $T_{Startup}$ and $T_{Bit-check}$, the current consumption is $I_S = I_{Son}$. The condition of the receiver is indicated on pin IC_ACTIVE. The average current consumption in polling mode is dependent on the duty cycle of the active mode and can be calculated as:

$$I_{Spoll} = \frac{I_{Soff} \times T_{Sleep} + I_{Son} \times (T_{Startup} + T_{Bit-check})}{T_{Sleep} + T_{Startup} + T_{Bit-check}}$$

During T_{Sleep} and $T_{Startup}$, the receiver is not sensitive to a transmitter signal. To guarantee the reception of a transmitted command, the transmitter must start the telegram with an adequate preburst. The required length of the preburst depends on the polling parameters T_{Sleep} , $T_{Startup}$, $T_{Bit-check}$ and the start-up time of a connected microcontroller, $T_{Start_microcontroller}$. Thus, $T_{Bit-check}$ depends on the actual bit rate and the number of bits ($N_{Bit-check}$) to be tested.

The following formula indicates how to calculate the preburst length.

$$T_{Purburst} \geq T_{Sleep} + T_{Startup} + T_{Bit-check} + T_{Start_microcontroller}$$

8.1 Sleep Mode

The length of period T_{Sleep} is defined by the 5-bit word Sleep of the OPMODE register, the extension factor X_{Sleep} (according to [Table 11-8 on page 27](#)), and the basic clock cycle T_{Cik} . It is calculated to be:

$$T_{Sleep} = Sleep \times X_{Sleep} \times 1024 \times T_{Cik}$$

The maximum value of T_{Sleep} is about 60 ms if X_{Sleep} is set to 1. The time resolution is about 2 ms in that case. The sleep time can be extended to almost half a second by setting X_{Sleep} to 8. X_{Sleep} can be set to 8 by bit $X_{SleepStd}$ to "1".

Setting the configuration word Sleep to its maximal value puts the receiver into a permanent sleep mode. The receiver remains in this state until another value for Sleep is programmed into the OPMODE register. This is particularly useful when several devices share a single data line. (It can also be used for microcontroller polling: using pin POLLING/_ON, the receiver can be switched on and off.)

Figure 8-1. Polling Mode Flow Chart

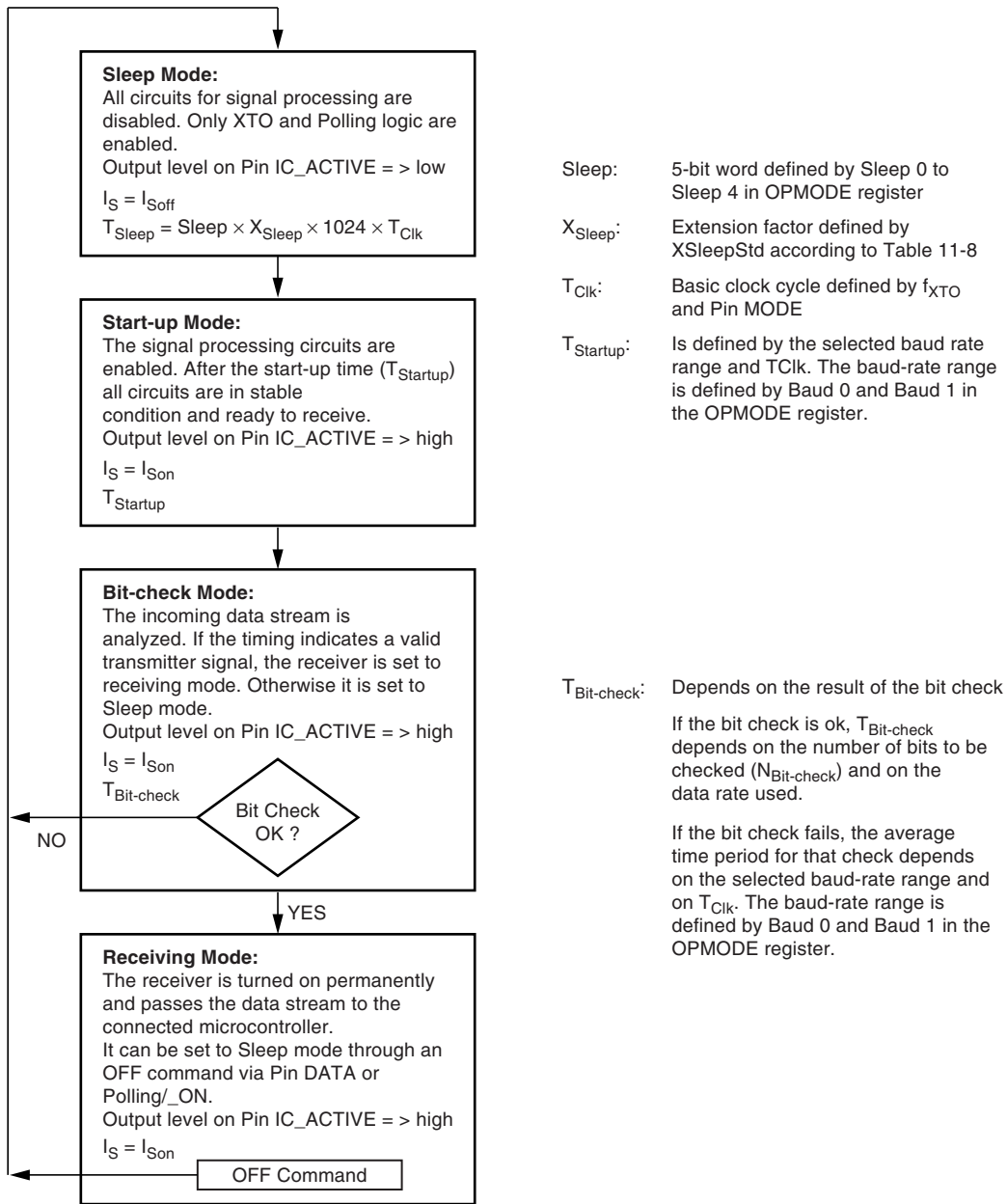

8.2 Bit-check Mode

In bit-check mode the incoming data stream is examined to distinguish between a valid signal from a corresponding transmitter and signals due to noise. This is done by subsequent time frame checks where the distances between 2 signal edges are continuously compared to a programmable time window. The maximum number of these edge-to-edge tests, before the receiver switches to receiving mode, is also programmable.

8.3 Configuring the Bit Check

Assuming a modulation scheme that contains two edges per bit, two time frame checks verify one bit. This is valid for Manchester, Bi-phase, and most other modulation schemes. The maximum count of bits to be checked can be set to 0, 3, 6, or 9 bits using the variable $N_{\text{Bit-check}}$ in the OPMODE register. This implies 0, 6, 12, and 18 edge-to-edge checks respectively. If $N_{\text{Bit-check}}$ is set to a higher value, the receiver is less likely to switch to receiving mode due to noise. In the presence of a valid transmitter signal, the bit check takes less time if $N_{\text{Bit-check}}$ is set to a lower value. In polling mode, the bit-check time is not dependent on $N_{\text{Bit-check}}$. Figure 8-2 shows an example where three bits are tested successfully and the data signal is transferred to pin DATA.

Figure 8-2. Timing Diagram for Complete Successful Bit Check

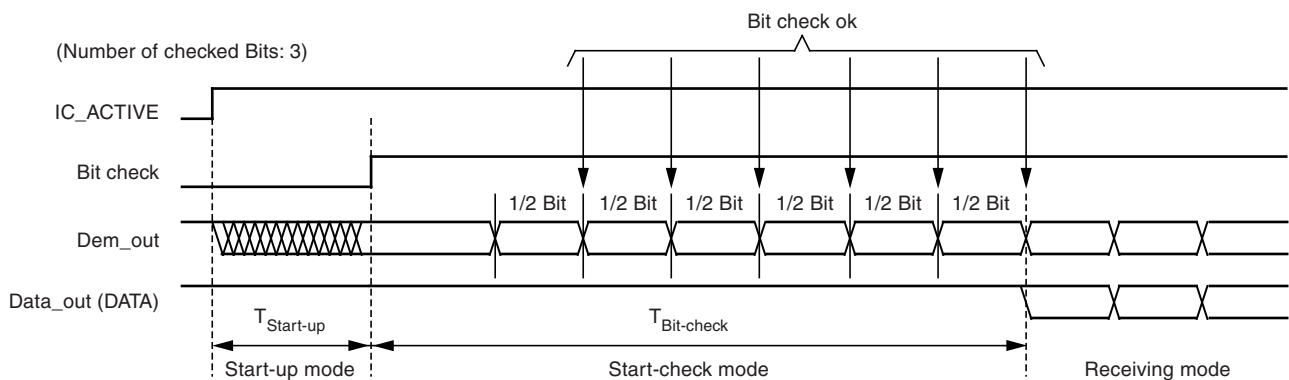

According to Figure 8-3, the time window for the bit check is defined by two separate time limits. If the edge-to-edge time t_{ee} is in between the lower bit-check limit $T_{\text{Lim_min}}$ and the upper bit-check limit $T_{\text{Lim_max}}$, the check continues. If t_{ee} is smaller than $T_{\text{Lim_min}}$ or t_{ee} exceeds $T_{\text{Lim_max}}$, the bit check is terminated and the receiver switches to sleep mode.

Figure 8-3. Valid Time Window for Bit Check

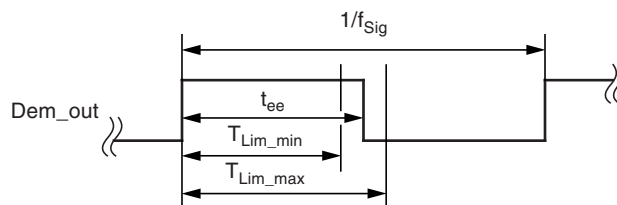

For best noise immunity using a low span between T_{Lim_min} and T_{Lim_max} is recommended. This is achieved using a fixed frequency at a 50% duty cycle for the transmitter preburst. A “11111...” or a “10101...” sequence in Manchester or Bi-phase is suitable for this. A good compromise between receiver sensitivity and susceptibility to noise is a time window of $\pm 30\%$ regarding the expected edge-to-edge time t_{ee} . Using pre-burst patterns that contain various edge-to-edge time periods, the bit-check limits must be programmed according to the required span.

The bit-check limits are determined by means of the formula below.

$$T_{Lim_min} = Lim_min \times T_{XClk}$$

$$T_{Lim_max} = (Lim_max - 1) \times T_{XClk}$$

Lim_min and Lim_max are defined by a 5-bit word each within the LIMIT register.

Using above formulas, Lim_min and Lim_max can be determined according to the required T_{Lim_min} , T_{Lim_max} and T_{XClk} . The time resolution defining T_{Lim_min} and T_{Lim_max} is T_{XClk} . The minimum edge-to-edge time t_{ee} ($t_{DATA_L_min}$, $t_{DATA_H_min}$) is defined according to the [Section 8.6 “Digital Signal Processing” on page 16](#). The lower limit should be set to $Lim_min \geq 10$. The maximum value of the upper limit is $Lim_max = 63$.

If the calculated value for Lim_min is < 19 , it is recommended to check 6 or 9 bits ($N_{Bit-check}$) to prevent switching to receiving mode due to noise.

[Figure 8-4](#), [Figure 8-5](#), and [Figure 8-6](#) illustrate the bit check for the bit-check limits $Lim_min = 14$ and $Lim_max = 24$. When the IC is enabled, the signal processing circuits are enabled during $T_{Startup}$. The output of the ASK/FSK demodulator (Dem_out) is undefined during that period. When the bit check becomes active, the bit-check counter is clocked with the cycle T_{XClk} .

[Figure 8-4](#) shows how the bit check proceeds if the bit-check counter value CV_Lim is within the limits defined by Lim_min and Lim_max at the occurrence of a signal edge. In [Figure 8-5](#) the bit check fails as the value CV_Lim is lower than the limit Lim_min . The bit check also fails if CV_Lim reaches Lim_max . This is illustrated in [Figure 8-6](#).

Figure 8-4. Timing Diagram During Bit Check

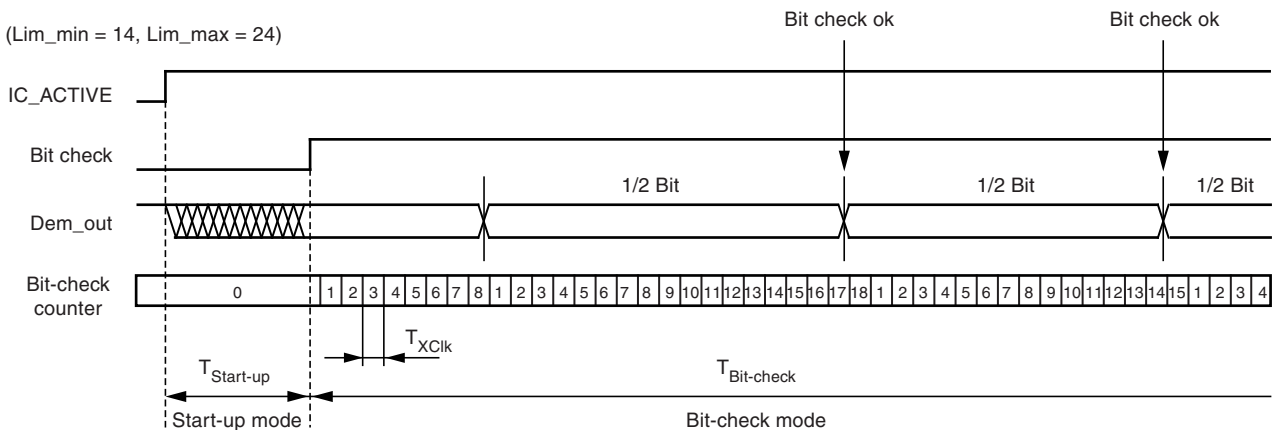

Figure 8-5. Timing Diagram for Failed Bit Check (Condition: $CV_Lim < Lim_min$)

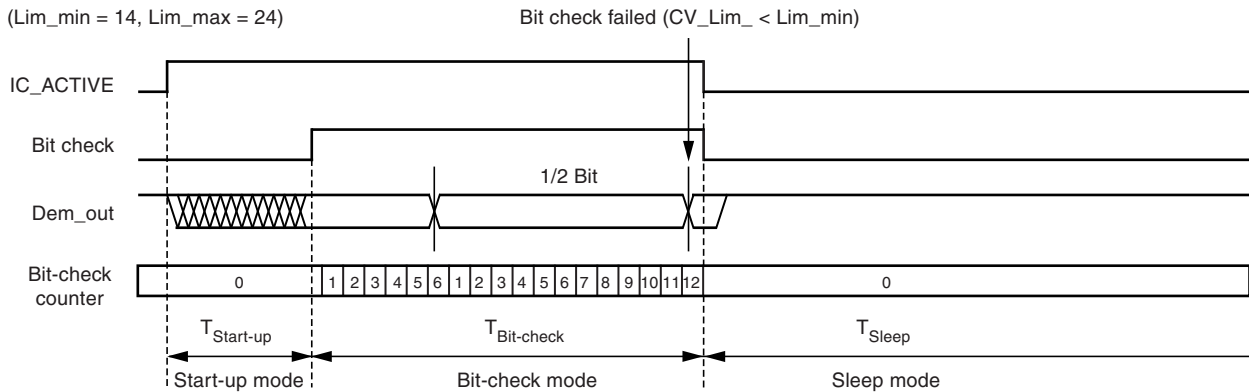
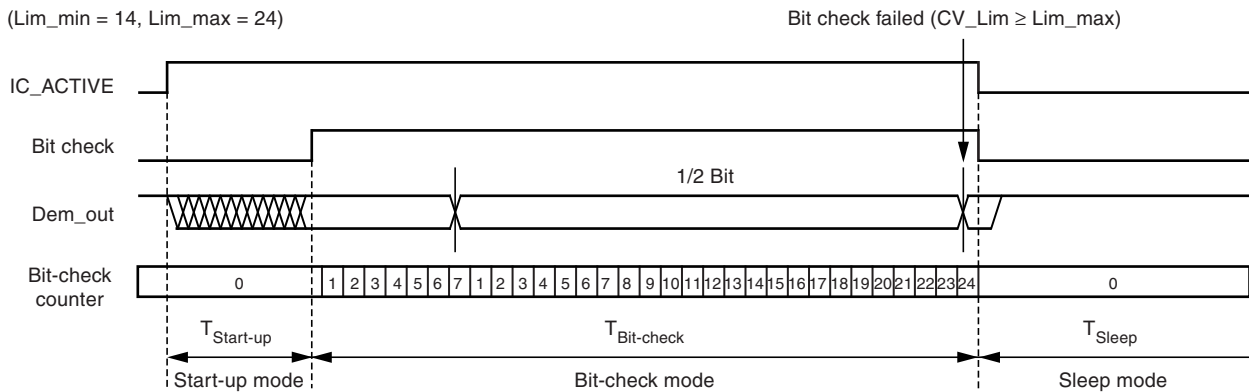

Figure 8-6. Timing Diagram for Failed Bit Check (Condition: $CV_Lim \geq Lim_max$)



8.4 Duration of the Bit Check

If no transmitter signal is present during the bit check, the output of the ASK/FSK demodulator delivers random signals. The bit check is a statistical process and $T_{Bit-check}$ varies for each check. Therefore, an average value for $T_{Bit-check}$ is given in the electrical characteristics. $T_{Bit-check}$ depends on the selected baud-rate range and on T_{Clk} . A higher baud-rate range causes a lower value for $T_{Bit-check}$ resulting in a lower current consumption in polling mode.

In the presence of a valid transmitter signal, $T_{Bit-check}$ is dependent on the frequency of that signal, f_{Sig} , and the count of the checked bits, $N_{Bit-check}$. A higher value for $N_{Bit-check}$ thereby results in a longer period for $T_{Bit-check}$ requiring a higher value for the transmitter pre-burst $T_{Preburst}$.

8.5 Receiving Mode

If the bit check was successful for all bits specified by $N_{Bit-check}$, the receiver switches to receiving mode. According to [Figure 8-2 on page 13](#), the internal data signal is switched to pin DATA in that case, and the data clock is available after the start bit has been detected (see [Figure 9-1 on page 20](#)). A connected microcontroller can be woken up by the negative edge at pin DATA or by the data clock at pin DATA_CLK. The receiver stays in that condition until it is switched back to polling mode explicitly.

8.6 Digital Signal Processing

The data from the ASK/FSK demodulator (Dem_out) is digitally processed in different ways and as a result converted into the output signal data. This processing depends on the selected baud-rate range (BR_Range). Figure 8-7 illustrates how Dem_out is synchronized by the extended clock cycle T_{XCik} . This clock is also used for the bit-check counter. Data can change its state only after T_{XCik} has elapsed. The edge-to-edge time period t_{ee} of the Data signal as a result is always an integral multiple of T_{XCik} .

The minimum time period between two edges of the data signal is limited to $t_{ee} \geq T_{DATA_min}$. This implies an efficient suppression of spikes at the DATA output. At the same time it limits the maximum frequency of edges at DATA. This eases the interrupt handling of a connected microcontroller.

The maximum time period for DATA to stay low is limited to $T_{DATA_L_max}$. This function is employed to ensure a finite response time in programming or switching off the receiver via pin DATA. $T_{DATA_L_max}$ is therefore longer than the maximum time period indicated by the transmitter data stream. Figure 8-9 on page 17 gives an example where Dem_out remains Low after the receiver has switched to receiving mode.

Figure 8-7. Synchronization of the Demodulator Output

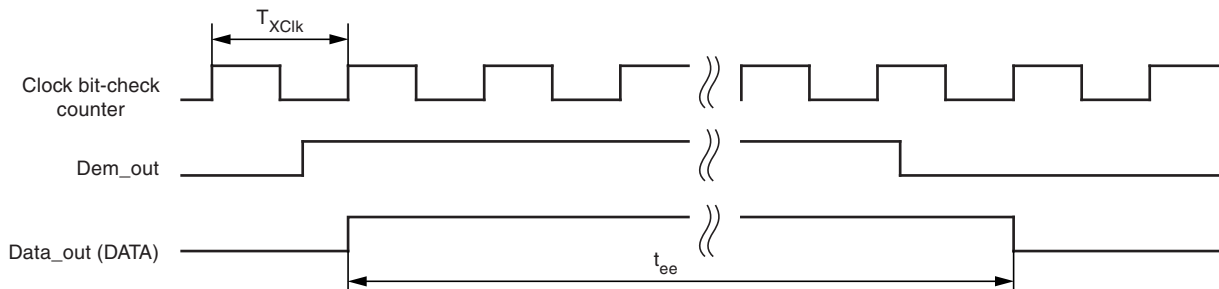

Figure 8-8. Debouncing of the Demodulator Output

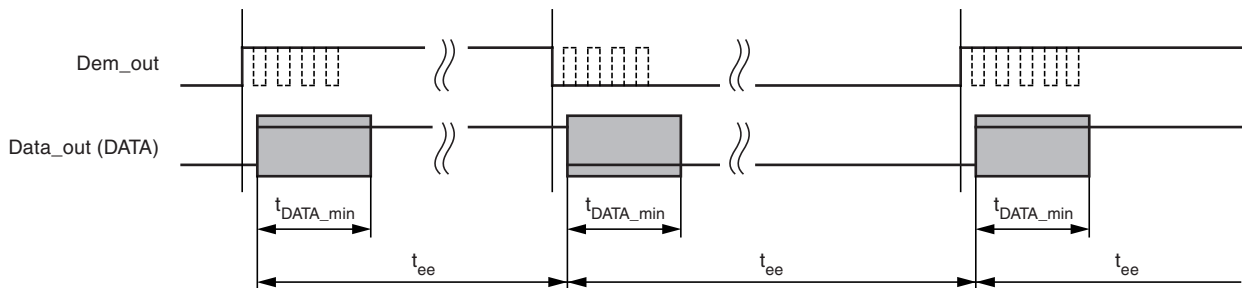
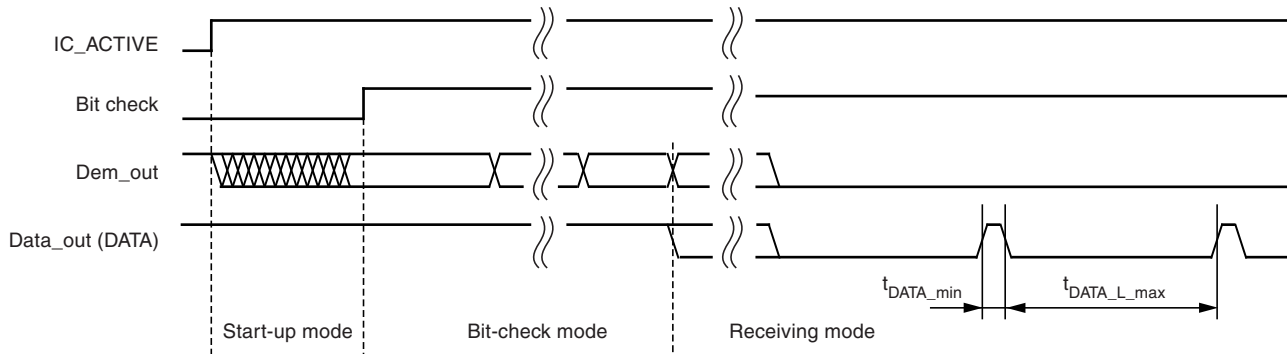

Figure 8-9. Steady L State Limited DATA Output Pattern After Transmission

After the end of a data transmission, the receiver remains active. Depending on the bit Noise_Disable in the OPMODE register, the output signal at pin DATA is high or random noise pulses appear at pin DATA (see [Section 10. “Digital Noise Suppression” on page 23](#)). The edge-to-edge time period t_{ee} of the majority of these noise pulses is equal or slightly higher than T_{DATA_min} .

8.7 Switching the Receiver Back to Sleep Mode

The receiver can be set back to polling mode via pin DATA or via pin POLLING/_ON.

When using pin DATA, this pin must be pulled to low by the connected microcontroller for the period t_1 . [Figure 8-10 on page 18](#) illustrates the timing of the OFF command (see [Figure 13-2 on page 30](#)). The minimum value of t_1 depends on the BR_Range. The maximum value for t_1 is not limited; however, exceeding the specified value to prevent erasing the reset marker is not recommended. Note also that an internal reset for the OPMODE and the LIMIT register is generated if t_1 exceeds the specified values. This item is explained in more detail in the [Section 11. “Configuring the Receiver” on page 25](#). Setting the receiver to sleep mode via DATA is achieved by programming bit 1 to “1” during the register configuration. Only one sync pulse (t_3) is issued.

The duration of the OFF command is determined by the sum of t_1 , t_2 , and t_{10} . The sleep time T_{Sleep} elapses after the OFF command. Note that the capacitive load at pin DATA is limited (see [Section 14. “Data Interface” on page 32](#)).

Figure 8-10. Timing Diagram of the OFF Command using Pin DATA

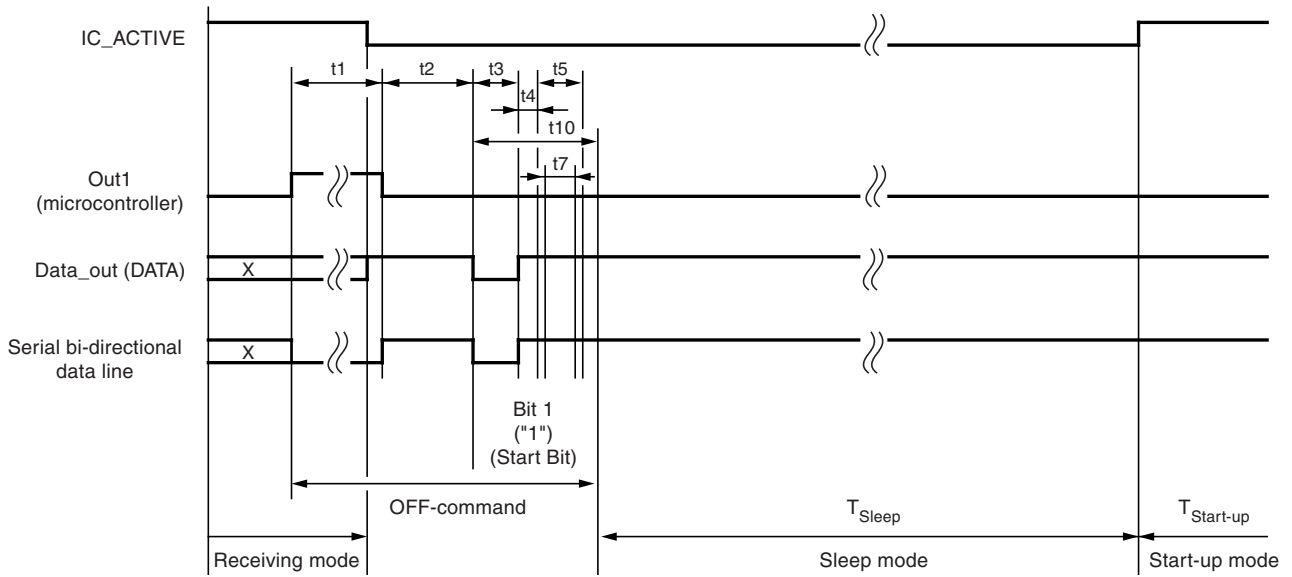

Figure 8-11. Timing Diagram of the OFF Command using Pin POLLING/_ON

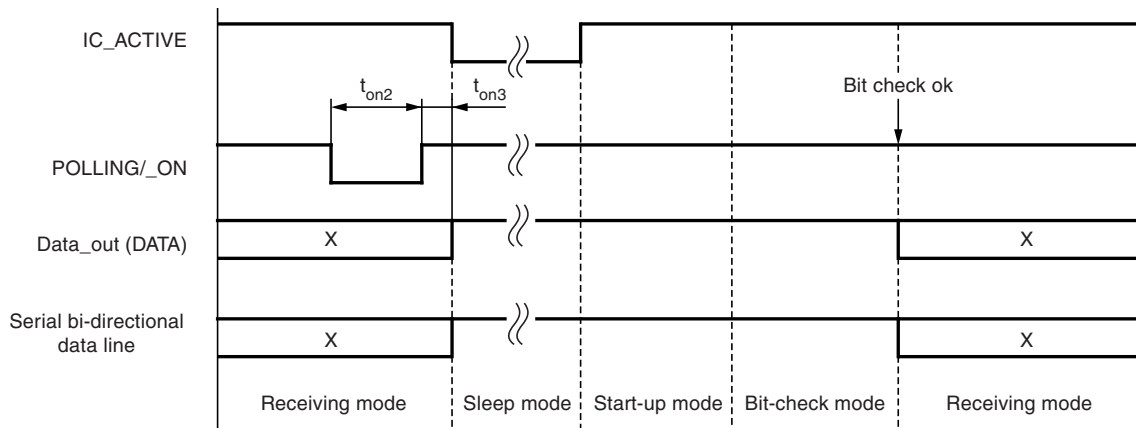

Figure 8-12. Activating the Receiving Mode using Pin POLLING/_ON

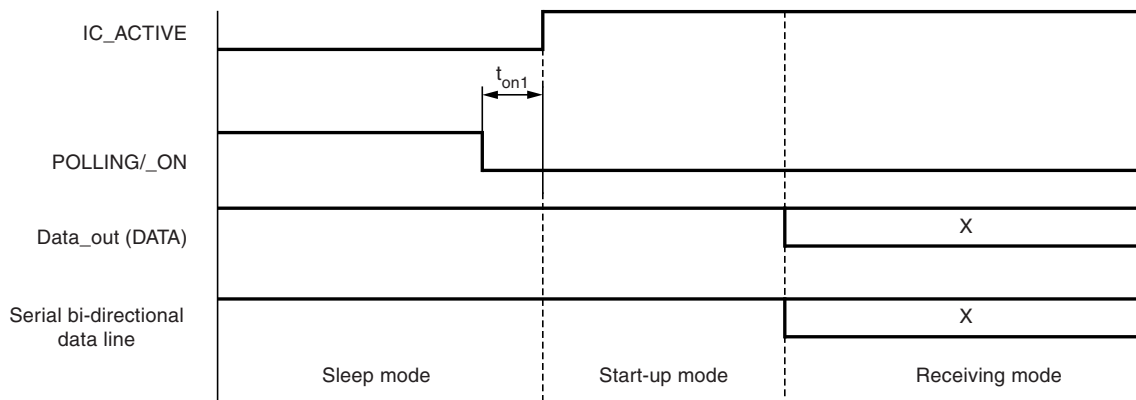

Figure 8-11 “Timing Diagram of the OFF Command using Pin POLLING/_ON” illustrates how to set the receiver back to polling mode using pin POLLING/_ON. The pin POLLING/_ON must be held to low for the time period t_{on2} . After the positive edge on pin POLLING/_ON and the delay t_{on3} , the polling mode is active and the sleep time T_{Sleep} elapses.

Using the POLLING/_ON command is faster than using pin DATA; however, this requires the use of an additional connection to the microcontroller.

Figure 8-12 “Activating the Receiving Mode using Pin “POLLING/_ON” illustrates how to set the receiver to receiving mode using the pin POLLING/_ON. The pin POLLING/_ON must be held to low. After the delay t_{on1} , the receiver changes from sleep mode to start-up mode regardless of the programmed values for T_{Sleep} and $N_{Bit-check}$. As long as POLLING/_ON is held to low, the values for T_{Sleep} and $N_{Bit-check}$ is ignored, but not deleted (see [Section 10. “Digital Noise Suppression” on page 23](#)).

If the receiver is polled exclusively by a microcontroller, T_{Sleep} must be programmed to 31 (permanent sleep mode). In this case the receiver remains in sleep mode as long as POLLING/_ON is held to high.

9. Data Clock

The pin DATA_CLK makes a data shift clock available to sample the data stream into a shift register. Using this data clock, a microcontroller can easily synchronize the data stream. This clock can only be used for Manchester and Bi-phase coded signals.

9.1 Generation of the Data Clock

After a successful bit check, the receiver switches from polling mode to receiving mode and the data stream is available at pin DATA. In receiving mode, the data clock control logic (Manchester/Bi-phase demodulator) is active and examines the incoming data stream. This is done, as with the bit check, by subsequent time frame checks where the distance between two edges is continuously compared to a programmable time window. As illustrated in [Figure 9-1 on page 20](#), only two distances between two edges in Manchester and Bi-phase coded signals are valid (T and $2T$).

The limits for T are the same as used with the bit check. They can be programmed in the LIMIT-register (Lim_min and Lim_max , see [Table 11-10 on page 28](#) and [Table 11-11 on page 28](#)).

The limits for $2T$ are calculated as follows:

$$\text{Lower limit of } 2T: \quad Lim_min_2T = (Lim_min + Lim_max) - (Lim_max - Lim_min)/2$$

$$\text{Upper limit of } 2T: \quad Lim_max_2T = (Lim_min + Lim_max) + (Lim_max - Lim_min)/2$$

(If the result for 'Lim_min_2T' or 'Lim_max_2T' is not an integer value, it is rounded up.)

The data clock is available, after the data clock control logic has detected the distance $2T$ (Start bit) and is issued with the delay t_{Delay} after the edge on pin DATA (see [Figure 9-1 on page 20](#)).

If the data clock control logic detects a timing or logical error (Manchester code violation), as illustrated in [Figure 9-2 on page 20](#) and [Figure 9-3 on page 21](#), it stops the output of the data clock. The receiver remains in receiving mode and starts with the bit check. If the bit check was successful and the start bit has been detected, the data clock control logic starts again with the generation of the data clock (see [Figure 9-4 on page 21](#)).

Use the function of the data clock only in conjunction with the bit check 3, 6 or 9 is recommended. If the bit check is set to 0 or the receiver is set to receiving mode using the pin POLLING/_ON, the data clock is available if the data clock control logic has detected the distance 2T (Start bit).

Note that for Bi-phase-coded signals, the data clock is issued at the end of the bit.

Figure 9-1. Timing Diagram of the Data Clock

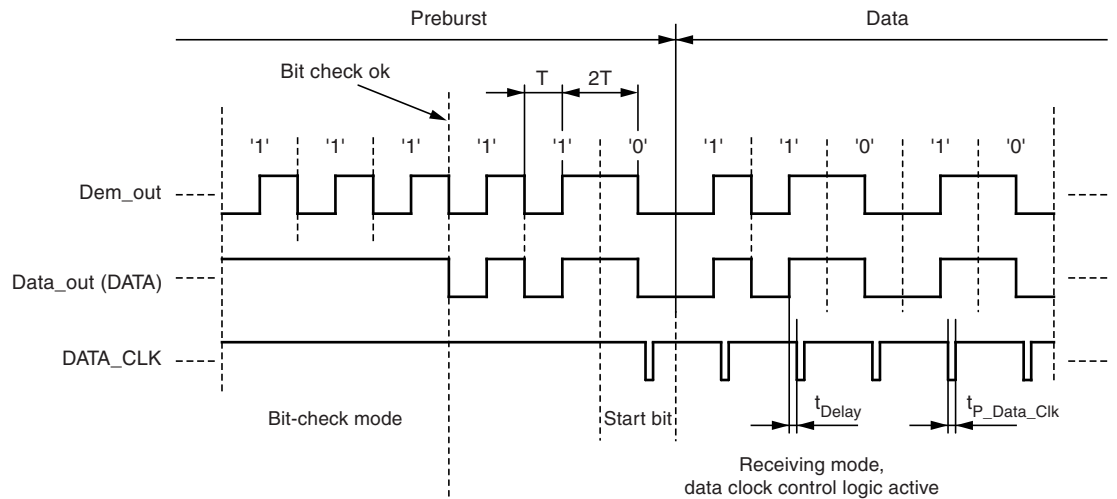

Figure 9-2. Data Clock Disappears Because of a Timing Error

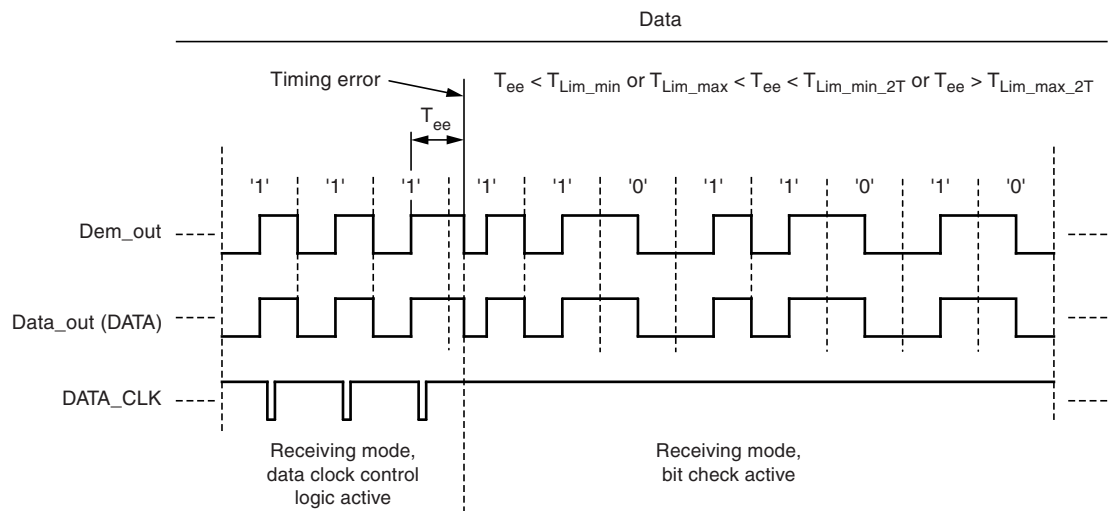

Figure 9-3. Data Clock Disappears Because of a Logical Error

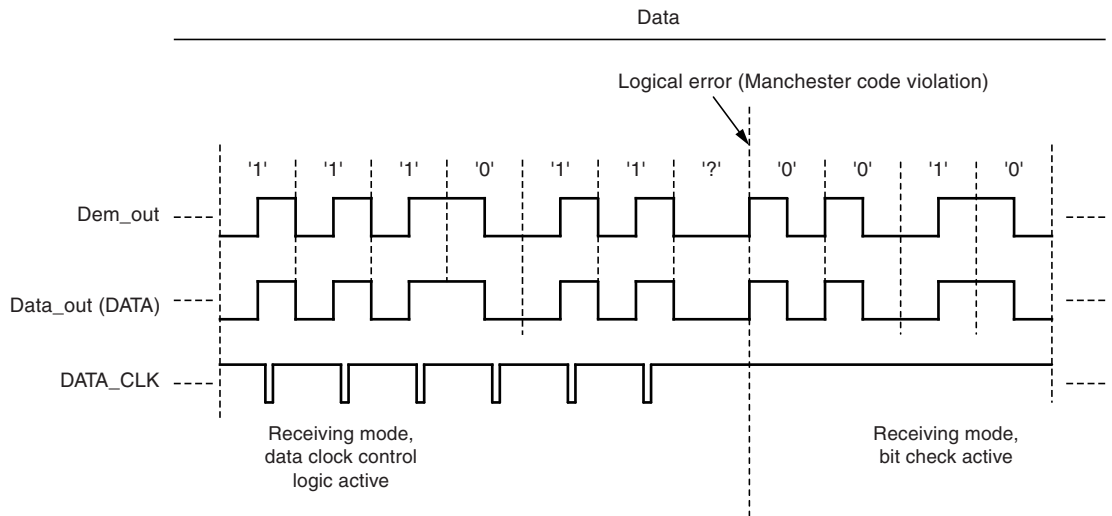
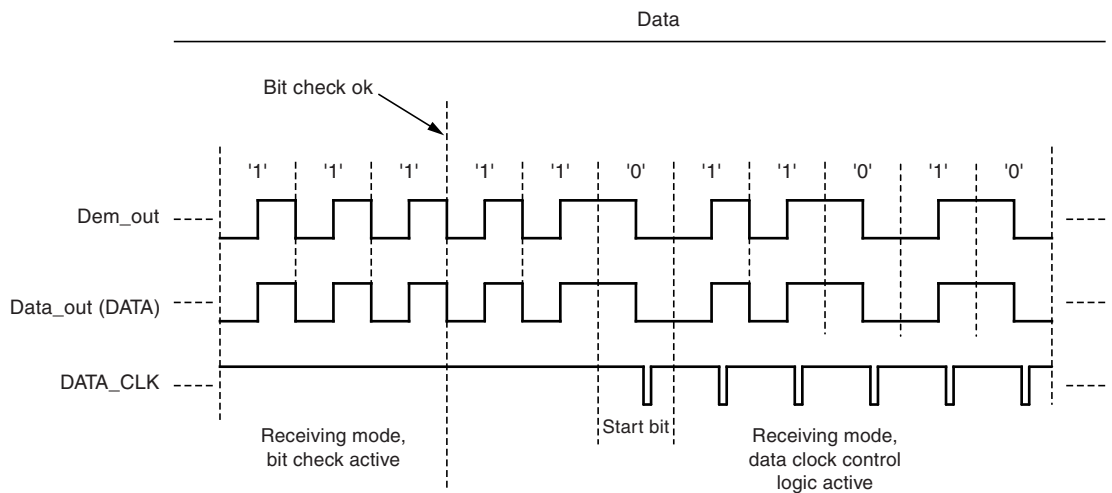

Figure 9-4. Output of the Data Clock After a Successful Bit Check



The delay of the data clock is calculated as follows: $t_{\text{Delay}} = t_{\text{Delay1}} + t_{\text{Delay2}}$

t_{Delay1} is the delay between the internal signals Data_Out and Data_In. For the rising edge, t_{Delay1} depends on the capacitive load C_L at pin DATA and the external pull-up resistor R_{pup} . For the falling edge, t_{Delay1} depends additionally on the external voltage V_X (see [Figure 9-5](#), [Figure 9-6 on page 22](#) and [Figure 13-2 on page 30](#)). When the level of Data_In is equal to the level of Data_Out, the data clock is issued after an additional delay t_{Delay2} .

Note that the capacitive load at pin DATA is limited. If the maximum tolerated capacitive load at pin DATA is exceeded, the data clock disappears (see [Section 14. "Data Interface" on page 32](#)).

Figure 9-5. Timing Characteristic of the Data Clock (Rising Edge on Pin DATA)

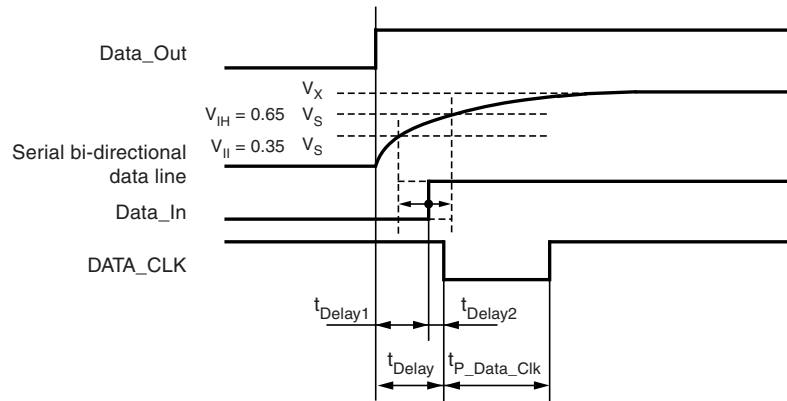
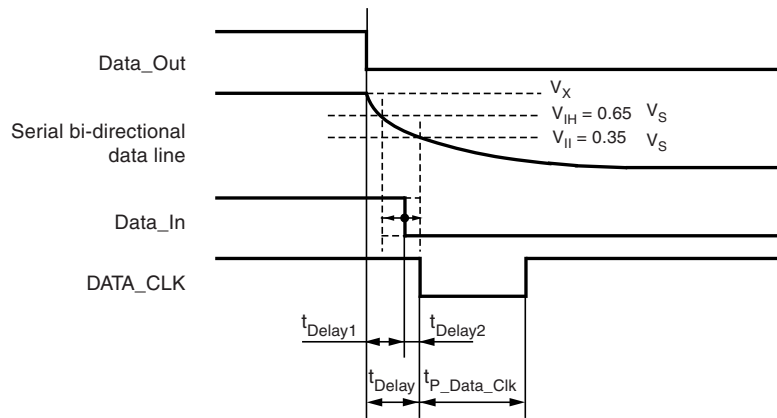

Figure 9-6. Timing Characteristic of the Data Clock (Falling Edge of the Pin DATA)



10. Digital Noise Suppression

After a data transmission, digital noise appears on the data output (see Figure 10-1 “Output of Digital Noise at the End of the Data Stream”). To prevent digital noise keeping the connected microcontroller busy, it can be suppressed in two different ways:

- Automatic Noise Suppression
- Controlled Noise Suppression by the Microcontroller

10.1 Automatic Noise Suppression

The receiver changes to bit-check mode at the end of a valid data stream if the bit Noise_Disable (Table 11-9 on page 27) in the OPMODE register is set to 1 (default). The digital noise is suppressed, and the level at pin DATA is high. The receiver changes back to receiving mode, if the bit check was successful.

This method of noise suppression is recommended if the data stream is Manchester or Bi-phase coded and is active after power on.

Figure 10-3 “Occurrence of a Pulse at the End of the Data Stream” illustrates the behavior of the data output at the end of a data stream. If the last period of the data stream is a high period (rising edge to falling edge), a pulse occurs on pin DATA. The length of the pulse depends on the selected baud-rate range.

Figure 10-1. Output of Digital Noise at the End of the Data Stream

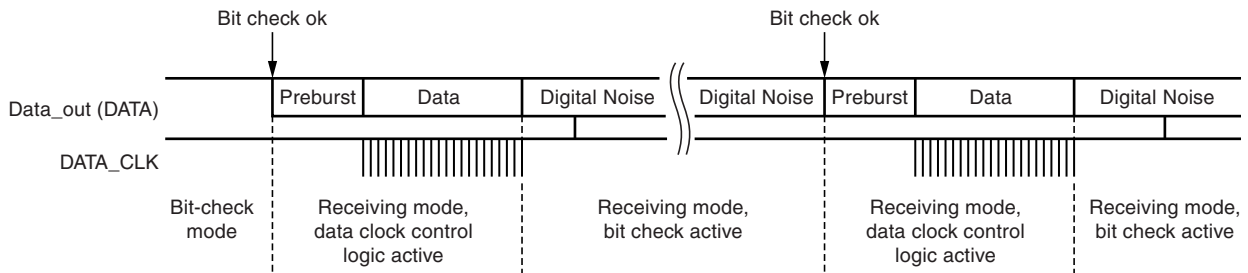

Figure 10-2. Automatic Noise Suppression

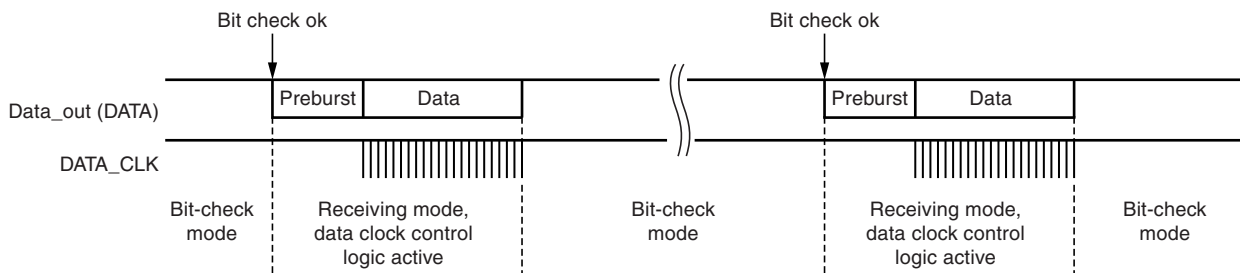
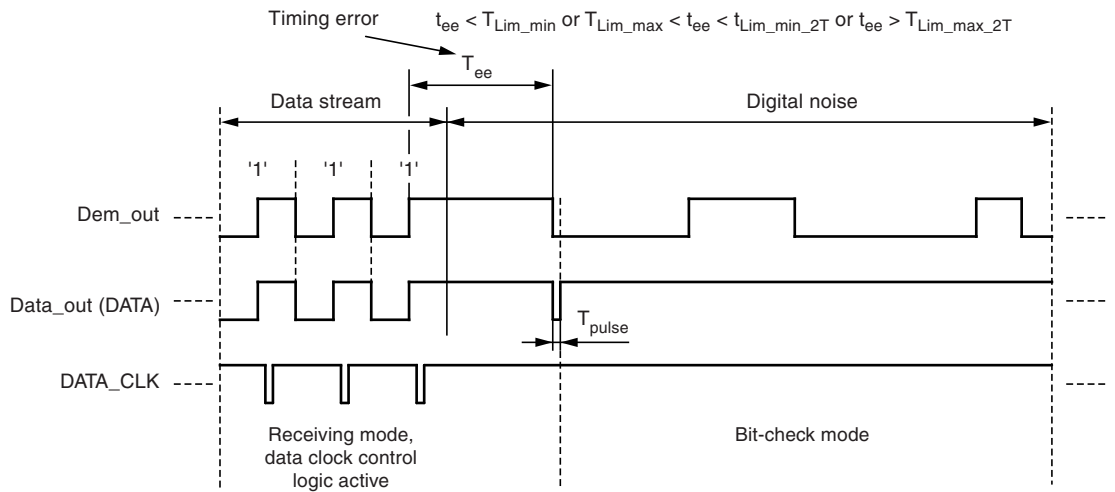

Figure 10-3. Occurrence of a Pulse at the End of the Data Stream



10.2 Controlled Noise Suppression by the Microcontroller

Digital noise appears at the end of a valid data stream if the bit Noise_Disable (see [Table 11-9 on page 27](#)) in the OPMODE register is set to 0. To suppress the noise, the pin POLLING/_ON must be set to low. The receiver remains in receiving mode. The OFF command then causes a change to start-up mode. The programmed sleep time (see [Table 11-7 on page 27](#)) is not executed because the level at pin POLLING/_ON is low; however, the bit check is active in this case. The OFF command also activates the bit check if the pin POLLING/_ON is held to low. The receiver changes back to receiving mode if the bit check was successful. To activate the polling mode at the end of the data transmission, the pin POLLING/_ON must be set to high. This way of suppressing the noise is recommended if the data stream is not Manchester or Bi-phase coded.

Figure 10-4. Controlled Noise Suppression

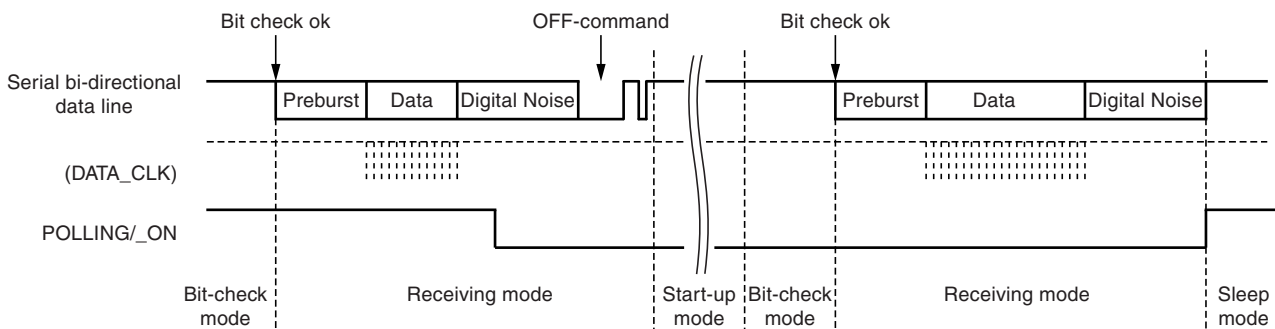

11. Configuring the Receiver

The ATA5723/ATA5724/ATA5728 receiver is configured using two 12-bit RAM registers called OPMODE and LIMIT. The registers can be programmed by means of the bidirectional DATA port. If the register content has changed due to a voltage drop, this condition is indicated by the output pattern called reset marker (RM). If this occurs, the receiver must be reprogrammed. After a Power-On Reset (POR), the registers are set to default mode. If the receiver is operated in default mode, there is no need to program the registers. Table 11-3 on page 25 shows the structure of the registers. According to Table 11-1, bit 1 defines whether the receiver is set back to polling mode using the OFF command (see “Receiving Mode” on page 15) or whether it is programmed. Bit 2 represents the register address. It selects the appropriate register to be programmed. For high programming reliability, bit 15 (Stop bit), at the end of the programming operation, must be set to 0.

Table 11-1. Effect of Bit 1 and Bit 2 on Programming the Registers

Bit 1	Bit 2	Action
1	x	The receiver is set back to polling mode (OFF command)
0	1	The OPMODE register is programmed
0	0	The LIMIT register is programmed

Table 11-2. Effect of Bit 15 on Programming the Register

Bit 15	Action
0	The values are written into the register (OPMODE or LIMIT)
1	The values are not written into the register

Table 11-3. Effect of the Configuration Words within the Registers

Bit 1	Bit 2	Bit 3	Bit 4	Bit 5	Bit 6	Bit 7	Bit 8	Bit 9	Bit 10	Bit 11	Bit 12	Bit 13	Bit 14	Bit 15	
OFF command															
1	–	–	–	–	–	–	–	–	–	–	–	–	–	–	
OPMODE register														–	
0	1	BR_Range		N _{Bit-check}		Modulation	Sleep					X _{Sleep}	Noise Suppression	0	
		Baud1	Baud0	BitChk1	BitChk0	ASK/_FSK	Sleep4	Sleep3	Sleep2	Sleep1	Sleep0	X _{SleepStd}	Noise_Disable		
Default values of Bit 3...14		0	0	0	1	0	0	0	1	1	0	0	1	–	
LIMIT register														–	
0	0	Lim_min					Lim_max								–
		Lim_min5	Lim_min4	Lim_min3	Lim_min2	Lim_min1	Lim_min0	Lim_max5	Lim_max4	Lim_max3	Lim_max2	Lim_max1	Lim_max0	0	
Default values of Bit 3...14		0	1	0	1	0	1	1	0	1	0	0	1	–	



The following tables illustrate the effect of the individual configuration words. The default configuration is highlighted for each word.

BR_Range sets the appropriate baud-rate range and simultaneously defines XLim. XLim is used to define the bit-check limits T_{Lim_min} and T_{Lim_max} as shown in [Table 11-10 on page 28](#) and [Table 11-11 on page 28](#).

Table 11-4. Effect of the configuration word BR_Range

BR_Range		Baud-rate Range/Extension Factor for Bit-check Limits (XLim)
Baud1	Baud0	
0	0	BR_Range0 (BR_Range0 = 1.0 kBit/s to 1.8 kBit/s) XLim = 8 (default)
0	1	BR_Range1 (BR_Range1 = 1.8 kBit/s to 3.2 kBit/s) XLim = 4
1	0	BR_Range2 (BR_Range2 = 3.2 kBit/s to 5.6 kBit/s) XLim = 2
1	1	BR_Range3 (BR_Range3 = 5.6 kBit/s to 10 kBit/s) XLim = 1

Table 11-5. Effect of the Configuration word $N_{Bit-check}$

$N_{Bit-check}$		Number of Bits to be Checked
BitChk1	BitChk0	
0	0	0
0	1	3 (default)
1	0	6
1	1	9

Table 11-6. Effect of the Configuration Bit Modulation

Modulation	Selected Modulation
ASK/_FSK	–
0	FSK (default)
1	ASK

Table 11-7. Effect of the Configuration Word Sleep

Sleep					Start Value for Sleep Counter ($T_{Sleep} = Sleep \times X_{Sleep} \times 1024 \times T_{Clk}$)
Sleep4	Sleep3	Sleep2	Sleep1	Sleep0	
0	0	0	0	0	0 (Receiver polls continuously until a valid signal occurs)
0	0	0	0	1	If $X_{Sleep} = 1$ $T_{Sleep} = 2.11$ ms for $f_{RF} = 868.3$ MHz, $T_{Sleep} = 2.12$ ms for $f_{RF} = 433.92$ MHz $T_{Sleep} = 2.08$ ms for $f_{RF} = 315$ MHz
0	0	0	1	0	2
0	0	0	1	1	3
...
0	0	1	1	0	If $X_{Sleep} = 1$ $T_{Sleep} = 12.69$ ms for $f_{RF} = 868.3$ MHz, $T_{Sleep} = 12.71$ ms for $f_{RF} = 433.92$ MHz $T_{Sleep} = 12.52$ ms for $f_{RF} = 315$ MHz
...
1	1	1	0	1	29
1	1	1	1	0	30
1	1	1	1	1	31 (permanent sleep mode)

Table 11-8. Effect of the Configuration Bit XSleep

X_{Sleep}	Extension Factor for Sleep Time ($T_{Sleep} = Sleep \times X_{Sleep} \times 1024 \times T_{Clk}$)
$X_{SleepStd}$	
0	1 (default)
1	8

Table 11-9. Effect of the Configuration Bit Noise Suppression

Noise Suppression	Suppression of the Digital Noise at Pin DATA
Noise_Disable	
0	Noise suppression is inactive
1	Noise suppression is active (default)



Table 11-10. Effect of the Configuration Word Lim_min

Lim_min ⁽¹⁾ (Lim_min < 10 is not Applicable)						Lower Limit Value for Bit Check
Lim_min5	Lim_min4	Lim_min3	Lim_min2	Lim_min1	Lim_min0	($T_{Lim_min} = Lim_min \times XLim \times T_{Clk}$)
0	0	1	0	1	0	10
0	0	1	0	1	1	11
0	0	1	1	0	0	12
..	
0	1	0	1	0	1	21 (default, BR_Range0) ($T_{Lim_min} = 347 \mu s$ for $f_{RF} = 868.3$ MHz $T_{Lim_min} = 347 \mu s$ for $f_{RF} = 433.92$ MHz $T_{Lim_min} = 342 \mu s$ for $f_{RF} = 315$ MHz)
..	
1	1	1	1	0	1	61
1	1	1	1	1	0	62
1	1	1	1	1	1	63

Note: 1. Lim_min is also used to determine the margins of the data clock control logic (see [Section 9. "Data Clock" on page 19](#)).

Table 11-11. Effect of the Configuration Word Lim_max

Lim_max ⁽¹⁾ (Lim_max < 12 is not applicable)						Upper Limit Value for Bit Check
Lim_max5	Lim_max4	Lim_max3	Lim_max2	Lim_max1	Lim_max0	($TLim_max = (Lim_max - 1) \times XLim \times T_{Clk}$)
0	0	1	1	0	0	12
0	0	1	1	0	1	13
0	0	1	1	1	0	14
..	
1	0	1	0	0	1	41 (default, BR_Range0) ($T_{Lim_max} = 661 \mu s$ for $f_{RF} = 868.3$ MHz $T_{Lim_max} = 662 \mu s$ for $f_{RF} = 433.92$ MHz $T_{Lim_max} = 652 \mu s$ for $f_{RF} = 315$ MHz)
..	
1	1	1	1	0	1	61
1	1	1	1	1	0	62
1	1	1	1	1	1	63

Note: 1. Lim_max is also used to determine the margins of the data clock control logic (see [Section 9. "Data Clock" on page 19](#)).

12. Conservation of the Register Information

The ATA5723/ATA5724 uses an integrated power-on reset and brown-out detection circuitry as a mechanism to preserve the RAM register information.

According to [Figure 12-1](#), a power-on reset (POR) is generated if the supply voltage V_S drops below the threshold voltage $V_{ThReset}$. The default parameters are programmed into the configuration registers in that condition. The POR is cancelled after the minimum reset period t_{Rst} when V_S exceeds $V_{ThReset}$. A POR is also generated when the supply voltage of the receiver is turned on.

To indicate that condition, the receiver displays a reset marker (RM) at pin DATA after a reset. The RM is represented by the fixed frequency f_{RM} at a 50% duty-cycle. RM can be cancelled using a low pulse t_1 at pin DATA. The RM has the following characteristics:

- f_{RM} is lower than the lowest feasible frequency of a data signal. Due to this, RM cannot be misinterpreted by the connected microcontroller.
- If the receiver is set back to polling mode using pin DATA, RM cannot be cancelled accidentally if t_1 is applied as described in the proposal in [Section 13. “Programming the Configuration Register”](#) on page 30.

Using this conservation mechanism, the receiver cannot lose its register information without communicating this condition using the reset marker RM.

Figure 12-1. Generation of the Power-on Reset

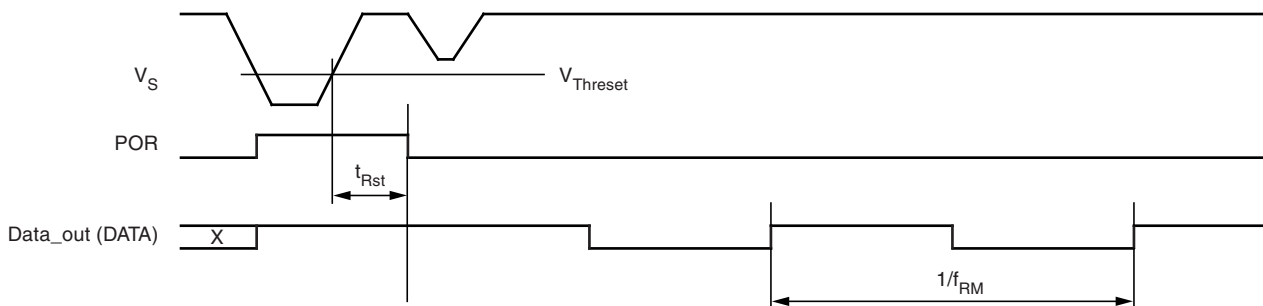

13. Programming the Configuration Register

Figure 13-1. Timing of the Register Programming

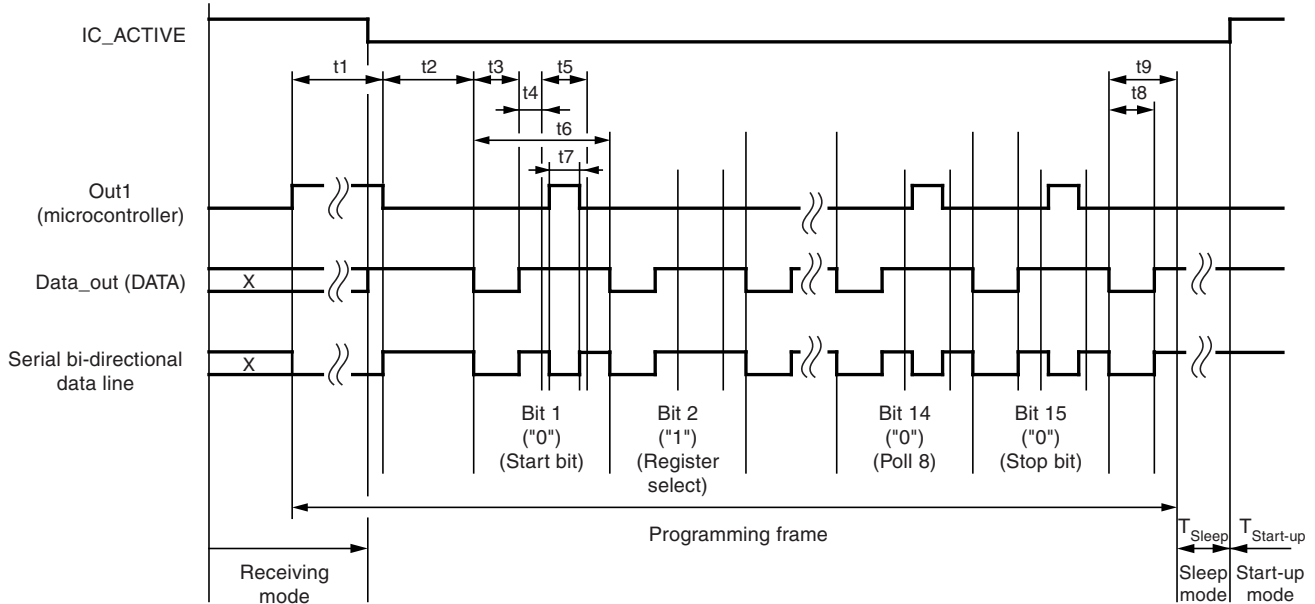
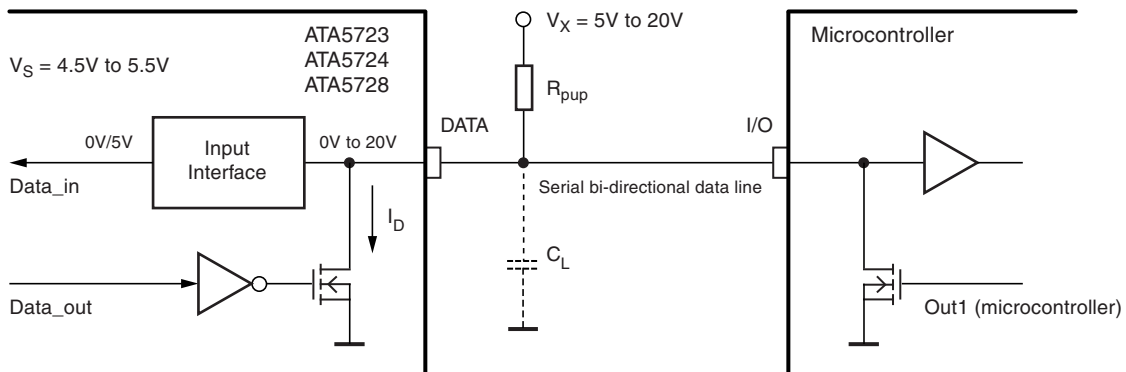

Figure 13-2. Data Interface



The configuration registers are serially programmed using the bi-directional data line as shown in Figure 13-1 and Figure 13-2.

To start programming, the serial data line DATA is pulled to low by the microcontroller for the time period t_1 . When DATA has been released, the receiver becomes the master device. When the programming delay period t_2 has elapsed, the receiver emits 15 subsequent synchronization pulses with the pulse length t_3 . After each of these pulses, a programming window occurs. The delay until the program window starts is determined by t_4 , the duration is defined by t_5 . The individual bits are set within the programming window. If the microcontroller pulls down pin DATA for the time period t_7 during t_5 , the corresponding bit is set to "0". If no programming pulse t_7 is issued, this bit is set to "1". All 15 bits are programmed this way. The time frame to program a bit is defined by t_6 .

Bit 15 is followed by the equivalent time window t_9 . During this window, the equivalence acknowledge pulse t_8 (E_Ack) occurs if the just programmed mode word is equivalent to the mode word that was already stored in that register. E_Ack should be used to verify that the mode word was correctly transferred to the register. The register must be programmed twice in that case.

A register can be programmed when the receiver is in both sleep-mode and active mode. During programming, the LNA, LO, low-pass filter, IF-amplifier, and the FSK/MSK demodulator are disabled. The t_1 pulse is used to start the programming or to switch the receiver back to polling mode (OFF command). (The receiver is switched back to polling mode with the OFF command if bit 1 is set to „1“.) The following convention should be considered for the length of the programming start pulse t_1 :

Using a t_1 value of $t_1(\text{min}) < t_1 < 5632 \text{ TCik}$ (where $t_1(\text{min})$ is the minimum specified value for the relevant BR_Range) when the receiver is active i.e., not in reset mode initiates the programming or OFF command. However, if this t_1 value is used when the receiver is in reset mode, programming or OFF command is NOT initiated and RM remains present at pin DATA. Note, the RM cannot be deleted when using this t_1 value.

Using a t_1 value of $t_1 > 7936 \text{ TCik}$, programming or OFF command is initiated when the receiver is in both reset mode and active mode. The registers PMODE and LIMIT are set to the default values and the RM is deleted, if present. This t_1 values can be used if the connected microcontroller detects an RM. Additionally, this t_1 value can generally be used if the receiver operates in default mode.

Note that the capacitive load at pin DATA is limited.

14. Data Interface

The data interface (see [Figure 13-2 on page 30](#)) is designed for automotive requirements. It can be connected using the pull-up resistor R_{pup} up to 20V and is short-circuit-protected.

The applicable pull-up resistor R_{pup} depends on the load capacity C_L at pin DATA and the selected BR_range (see [Table 14-1](#)).

Table 14-1. Applicable R_{pup}

-	BR_range	Applicable R_{pup}
$C_L \leq 1nF$	B0	1.6 k Ω to 47 k Ω
	B1	1.6 k Ω to 22 k Ω
	B2	1.6 k Ω to 12 k Ω
	B3	1.6 k Ω to 5.6 k Ω
$C_L \leq 100pF$	B0	1.6 k Ω to 470 k Ω
	B1	1.6 k Ω to 220 k Ω
	B2	1.6 k Ω to 120 k Ω
	B3	1.6 k Ω to 56 k Ω

Figure 14-1. Application Circuit: $f_{RF} = 315\text{ MHz}^{(1)}$, 433.92 MHz or without SAW Filter

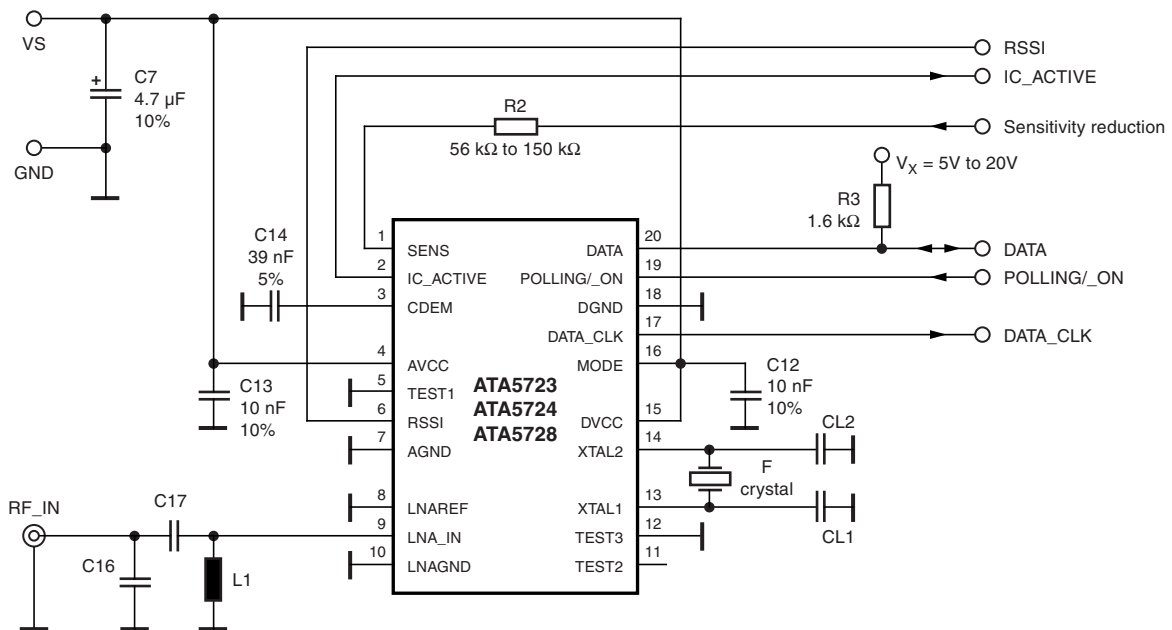

Note: For 315 MHz application pin MODE must be connected to GND.

Table 14-2. Input Matching to 50 Ω

RF Frequency (MHz)	LNA Matching			Crystal Frequency f_{XTAL} (MHz)
	C16 (pF)	C17 (pF)	L1 (nH)	
315	Not connected	3	39	14.71875
433.92	Not connected	3	20	13.52875
868.3	1	3	6.8	13.55234

15. Absolute Maximum Ratings

Stresses beyond those listed under “Absolute Maximum Ratings” may cause permanent damage to the device. This is a stress rating only and functional operation of the device at these or any other conditions beyond those indicated in the operational sections of this specification is not implied. Exposure to absolute maximum rating conditions for extended periods may affect device reliability.

Parameters	Symbol	Min.	Max.	Unit
Supply voltage	V_S		6	V
Power dissipation	P_{tot}		1000	mW
Junction temperature	T_j		150	°C
Storage temperature	T_{stg}	-55	+125	°C
Ambient temperature	T_{amb}	-40	+105	°C
Maximum input level, input matched to 50Ω	P_{in_max}		10	dBm

16. Thermal Resistance

Parameters	Symbol	Value	Unit
Junction ambient	R_{thJA}	100	K/W



17. Electrical Characteristics ATA5723

All parameters refer to GND, $T_{amb} = -40^{\circ}\text{C}$ to $+105^{\circ}\text{C}$, $V_S = 4.5\text{V}$ to 5.5V , $f_0 = 315\text{ MHz}$ unless otherwise specified
(For typical values: $V_S = 5\text{V}$, $T_{amb} = 25^{\circ}\text{C}$).

No.	Parameter	Test Conditions	Symbol	$f_{RF} = 315\text{ MHz}$ 14.71875 MHz Oscillator			Variable Oscillator			Unit	Type*				
				Min.	Typ.	Max.	Min.	Typ.	Max.						
1 Basic Clock Cycle of the Digital Circuitry															
1.1	Basic clock cycle		T_{Clk}	2.0382		2.0382				$30/f_{XTO}$		$30/f_{XTO}$	μs	A	
1.2	Extended basic clock cycle	BR_Range0 BR_Range1 BR_Range2 BR_Range3	T_{XClk}	16.3057 8.1528 4.0764 2.0382		16.3057 8.1528 4.0764 2.0382				$8 \times T_{Clk}$ $4 \times T_{Clk}$ $2 \times T_{Clk}$ $1 \times T_{Clk}$		$8 \times T_{Clk}$ $4 \times T_{Clk}$ $2 \times T_{Clk}$ $1 \times T_{Clk}$	μs μs μs μs	A	
2 Polling Mode															
2.1	Sleep time (see Figure 8-1, Figure 8-10 and Figure 13-1)	Sleep and XSleep are defined in the OPMODE register	T_{Sleep}	$Sleep \times X_{Sleep} \times 1024 \times 2.0382$		$Sleep \times X_{Sleep} \times 1024 \times 2.0382$				$Sleep \times X_{Sleep} \times 1024 \times T_{Clk}$		$Sleep \times X_{Sleep} \times 1024 \times T_{Clk}$	ms	A	
2.2	Start-up time (see Figure 8-1 and Figure 8-4)	BR_Range0 BR_Range1 BR_Range2 BR_Range3	$T_{Startup}$	1827 1044 1044 653		1827 1044 1044 653				896.5 512.5 512.5 320.5 $\times T_{Clk}$		896.5 512.5 512.5 320.5 $\times T_{Clk}$	μs μs μs μs μs	A	
2.3	Time for bit check (see Figure 8-1)	Average bit-check time while polling, no RF applied (see Figure 8-5 and Figure 8-6) BR_Range0 BR_Range1 BR_Range2 BR_Range3	$T_{Bit-check}$		0.45 0.24 0.14 0.08						0.45 0.24 0.14 0.08		ms ms ms ms	C	
2.4	Time for bit check (see Figure 8-1)	Bit-check time for a valid input signal f_{Sig} (see Figure 8-5) $N_{Bit-check} = 0$ $N_{Bit-check} = 3$ $N_{Bit-check} = 6$ $N_{Bit-check} = 9$	$T_{Bit-check}$		$1 \times T_{XClk}$ $3/f_{Sig}$ $6/f_{Sig}$ $9/f_{Sig}$		$1 \times T_{XClk}$ $3.5/f_{Sig}$ $6.5/f_{Sig}$ $9.5/f_{Sig}$				$1 \times T_{XClk}$ $3/f_{Sig}$ $6/f_{Sig}$ $9/f_{Sig}$		$1 \times T_{Clk}$ $3.5/f_{Sig}$ $6.5/f_{Sig}$ $9.5/f_{Sig}$	ms ms ms ms	C
3 Receiving Mode															
3.1	Intermediate frequency		f_{IF}		987					$f_{IF} = f_{LO}/318$			kHz	A	
3.2	Baud-rate range	BR_Range0 BR_Range1 BR_Range2 BR_Range3	BR_Range	1.0 1.8 3.2 5.6		1.8 3.2 5.6 10.0				$BR_Range0 \times 2 \mu\text{s}/T_{Clk}$ $BR_Range1 \times 2 \mu\text{s}/T_{Clk}$ $BR_Range2 \times 2 \mu\text{s}/T_{Clk}$ $BR_Range3 \times 2 \mu\text{s}/T_{Clk}$		kBit/s kBit/s kBit/s kBit/s	A		

*) Type means: A = 100% tested, B = 100% correlation tested, C = Characterized on samples, D = Design parameter

17. Electrical Characteristics ATA5723 (Continued)

All parameters refer to GND, $T_{amb} = -40^{\circ}\text{C}$ to $+105^{\circ}\text{C}$, $V_S = 4.5\text{V}$ to 5.5V , $f_0 = 315\text{ MHz}$ unless otherwise specified (For typical values: $V_S = 5\text{V}$, $T_{amb} = 25^{\circ}\text{C}$).

No.	Parameter	Test Conditions	Symbol	$f_{RF} = 315\text{ MHz}$ 14.71875 MHz Oscillator			Variable Oscillator			Unit	Type*				
				Min.	Typ.	Max.	Min.	Typ.	Max.						
3.3	Minimum time period between edges at pin DATA (see Figure 4-2 and Figure 8-8, Figure 8-9) (With the exception of parameter T_{Pulse})	BR_Range =	t_{DATA_min}									μs	A		
		BR_Range0		163.06					$10 \times T_{XClk}$	$10 \times T_{XClk}$					
		BR_Range1		81.53					$10 \times T_{XClk}$	$10 \times T_{XClk}$					
		BR_Range2		40.76					$10 \times T_{XClk}$	$10 \times T_{XClk}$					
		BR_Range3	20.38								$10 \times T_{XClk}$	$10 \times T_{XClk}$			
3.4	Maximum Low period at pin DATA (see Figure 4-2)	BR_Range =	$t_{DATA_L_max}$										μs	A	
		BR_Range0		2120					$130 \times T_{XClk}$	$130 \times T_{XClk}$					
		BR_Range1		1060					$130 \times T_{XClk}$	$130 \times T_{XClk}$					
		BR_Range2		530					$130 \times T_{XClk}$	$130 \times T_{XClk}$					
		BR_Range3	265								$130 \times T_{XClk}$	$130 \times T_{XClk}$			
3.5	Delay to activate the start-up mode (see Figure 8-12)		Ton1	19.36		21.4				$9.5 \times T_{Clk}$		$10.5 \times T_{Clk}$	μs	A	
3.6	OFF command at pin POLLING/_ON (see Figure 8-11)		Ton2	16.3						$8 \times T_{Clk}$			μs	A	
3.7	Delay to activate the sleep mode (see Figure 8-11)		Ton3	17.32		19.36				$8.5 \times T_{Clk}$		$9.5 \times T_{Clk}$	μs	A	
3.8	Pulse on pin DATA at the end of a data stream (see Figure 10-3)	BR_Range =	T_{Pulse}											μs	C
		BR_Range0		16.3							$8 \times T_{Clk}$	$8 \times T_{Clk}$			
		BR_Range1		8.15							$4 \times T_{Clk}$	$4 \times T_{Clk}$			
		BR_Range2		4.07							$2 \times T_{Clk}$	$2 \times T_{Clk}$			
		BR_Range3	2.04									$1 \times T_{Clk}$	$1 \times T_{Clk}$		

*) Type means: A = 100% tested, B = 100% correlation tested, C = Characterized on samples, D = Design parameter



17. Electrical Characteristics ATA5723 (Continued)

All parameters refer to GND, $T_{amb} = -40^{\circ}\text{C}$ to $+105^{\circ}\text{C}$, $V_S = 4.5\text{V}$ to 5.5V , $f_0 = 315\text{ MHz}$ unless otherwise specified
(For typical values: $V_S = 5\text{V}$, $T_{amb} = 25^{\circ}\text{C}$).

No.	Parameter	Test Conditions	Symbol	$f_{RF} = 315\text{ MHz}$ 14.71875 MHz Oscillator			Variable Oscillator			Unit	Type*		
				Min.	Typ.	Max.	Min.	Typ.	Max.				
4 Configuration of the Receiver (see Figure 12-1 and Figure 13-1)													
4.1	Frequency of the reset marker	Frequency is stable within 50 ms after POR	f_{RM}	119.78		119.78			$1/(4096 \times T_{Clk})$		$1/(4096 \times T_{Clk})$	Hz	A
4.2	Programming start pulse	BR_Range = BR_Range0 BR_Range1 BR_Range2 BR_Range3 after POR	t_1	3310 2242 1708 1441 16175		11479 11479 11479 11479			$1624 \times T_{Clk}$ $1100 \times T_{Clk}$ T_{Clk} $838 \times T_{Clk}$ $707 \times T_{Clk}$ $7936 \times T_{Clk}$		$5632 \times T_{Clk}$ $5632 \times T_{Clk}$ $5632 \times T_{Clk}$ $5632 \times T_{Clk}$	μs μs μs μs μs	A
4.3	Programming delay period		t_2	783		785			$384.5 \times T_{Clk}$		$385.5 \times T_{Clk}$	μs	A
4.4	Synchronization pulse		t_3	261		261			$128 \times T_{Clk}$		$128 \times T_{Clk}$	μs	A
4.5	Delay until of the program window starts		t_4	129		129			$63.5 \times T_{Clk}$		$63.5 \times T_{Clk}$	μs	A
4.6	Programming window		t_5	522		522			$256 \times T_{Clk}$		$256 \times T_{Clk}$	μs	A
4.7	Time frame of a bit		t_6	1044		1044			$512 \times T_{Clk}$		$512 \times T_{Clk}$	μs	A
4.8	Programming pulse		t_7	130.5		522			$64 \times T_{Clk}$		$256 \times T_{Clk}$	μs	C
4.9	Equivalent acknowledge pulse: E_Ack		t_8	261		261			$128 \times T_{Clk}$		$128 \times T_{Clk}$	μs	A
4.10	Equivalent time window		t_9	526		526			$258 \times T_{Clk}$		$258 \times T_{Clk}$	μs	A
4.11	OFF-bit programming window		t_{10}	916		916			$449.5 \times T_{Clk}$		$449.5 \times T_{Clk}$	μs	A
5 Data Clock (see Figure 9-1 and Figure 9-6)													
5.1	Minimum delay time between edge at DATA and DATA_CLK	BR_Range = BR_Range0 BR_Range1 BR_Range2 BR_Range3	t_{Delay2}	0 0 0 0		16.3057 8.1528 4.0764 2.0382			0 0 0 0		$1 \times T_{XClk}$ $1 \times T_{XClk}$ $1 \times T_{XClk}$ $1 \times T_{XClk}$	μs μs μs μs	C
5.2	Pulse width of negative pulse at pin DATA_CLK	BR_Range = BR_Range0 BR_Range1 BR_Range2 BR_Range3	$t_{P_DATA_CLK}$	65.2 32.6 16.3 8.15		65.2 32.6 16.3 8.15			$4 \times T_{XClk}$ $4 \times T_{XClk}$ $4 \times T_{XClk}$ $4 \times T_{XClk}$		$4 \times T_{XClk}$ $4 \times T_{XClk}$ $4 \times T_{XClk}$ $4 \times T_{XClk}$	μs μs μs μs	A

*) Type means: A = 100% tested, B = 100% correlation tested, C = Characterized on samples, D = Design parameter

18. Electrical Characteristics ATA5724, ATA5728

All parameters refer to GND, $T_{amb} = -40^{\circ}\text{C}$ to $+105^{\circ}\text{C}$, $V_S = 4.5\text{V}$ to 5.5V , $f_0 = 433.92\text{ MHz}$ and $f_0 = 868.3\text{ MHz}$ unless otherwise specified (For typical values: $V_S = 5\text{V}$, $T_{amb} = 25^{\circ}\text{C}$).

No.	Parameter	Test Conditions	Symbol	$f_{RF} = 433.92\text{ MHz}$ 13.52875 MHz Oscillator			$f_{RF} = 868.3\text{ MHz}$, 13.55234 MHz Oscillator			Variable Oscillator			Unit	Type*
				Min.	Typ.	Max.	Min.	Typ.	Max.	Min.	Typ.	Max.		
6 Basic Clock Cycle of the Digital Circuitry														
6.1	Basic clock cycle		T_{Clk}	2.0696		2.0696	2.066		2.066	$28/f_{XTO}$		$28/f_{XTO}$	μs	A
6.2	Extended basic clock cycle	BR_Range0	T_{XCik}	16.557		16.557	16.528		16.528	$8 \times T_{Clk}$		$8 \times T_{Clk}$	μs	A
		BR_Range1		8.278		8.278	8.264		8.264	$4 \times T_{Clk}$		$4 \times T_{Clk}$	μs	
		BR_Range2		4.139		4.139	4.132		4.132	$2 \times T_{Clk}$		$2 \times T_{Clk}$	μs	
		BR_Range3		2.069		2.069	2.066		2.066	$1 \times T_{Clk}$		$1 \times T_{Clk}$	μs	
7 Polling Mode														
7.1	Sleep time (see Figure 8-1, Figure 8-10 and Figure 13-1)	Sleep and XSleep are defined in the OPMODE register	T_{Sleep}	$Sleep \times X_{Sleep} \times 1024 \times 2.0696$		$Sleep \times X_{Sleep} \times 1024 \times 2.0696$	$Sleep \times X_{Sleep} \times 1024 \times 2.066$		$Sleep \times X_{Sleep} \times 1024 \times 2.066$	$Sleep \times X_{Sleep} \times 1024 \times T_{Clk}$		$Sleep \times X_{Sleep} \times 1024 \times T_{Clk}$	ms	A
7.2	Start-up time (see Figure 8-1 and Figure 8-4)	BR_Range0	$T_{Startup}$	1855		1855	1852		1852	896.5		896.5	μs	A
		BR_Range1		1060		1060	1058		1058	512.5		512.5	μs	
		BR_Range2		1060		1060	1058		1058	512.5		512.5	μs	
		BR_Range3		663		663	662		662	$320.5 \times T_{Clk}$		$320.5 \times T_{Clk}$	μs	
7.3	Time for bit check (see Figure 8-1)	Average bit-check time while polling, no RF applied (see Figure 8-8 on page 16 and Figure 8-9 on page 17) BR_Range0 BR_Range1 BR_Range2 BR_Range3	$T_{Bit-check}$											C
					0.45		0.45		0.45		0.45		ms	
					0.24		0.24		0.24		0.24		ms	
					0.14		0.14		0.14		0.14		ms	
7.4	Time for bit check (see Figure 8-1)	Bit-check time for a valid input signal f_{Sig} (see Figure 8-5 on page 15) $N_{Bit-check} = 0$ $N_{Bit-check} = 3$ $N_{Bit-check} = 6$ $N_{Bit-check} = 9$	$T_{Bit-check}$	$1 \times T_{XCik}$		$1 \times T_{XCik}$	$1 \times T_{XCik}$		$1 \times T_{XCik}$	$1 \times T_{XCik}$		$1 \times T_{XCik}$	ms	C
				$3/f_{Sig}$		$3.5/f_{Sig}$	$3/f_{Sig}$		$3.5/f_{Sig}$	$3/f_{Sig}$		$3.5/f_{Sig}$	ms	
				$6/f_{Sig}$		$6.5/f_{Sig}$	$6/f_{Sig}$		$6.5/f_{Sig}$	$6/f_{Sig}$		$6.5/f_{Sig}$	ms	
				$9/f_{Sig}$		$9.5/f_{Sig}$	$9/f_{Sig}$		$9.5/f_{Sig}$	$9/f_{Sig}$		$9.5/f_{Sig}$	ms	
8 Receiving Mode														
8.1	Intermediate frequency		f_{IF}		987			947.9		$f_{IF} = f_{LO}/438$ for the 433.92 MHz band (ATA5724) $f_{IF} = f_{LO}/915$ for the 868.3 MHz band (ATA5728)		kHz	A	
8.2	Baud-rate range	BR_Range0	BR_Range	1.0		1.8	1.0		1.8	$BR_Range0 \times 2 \mu\text{s}/T_{Clk}$		$BR_Range0 \times 2 \mu\text{s}/T_{Clk}$	kBit/s	A
		BR_Range1		1.8		3.2	1.8		3.2	$BR_Range1 \times 2 \mu\text{s}/T_{Clk}$		$BR_Range1 \times 2 \mu\text{s}/T_{Clk}$	kBit/s	
		BR_Range2		3.2		5.6	3.2		5.6	$BR_Range2 \times 2 \mu\text{s}/T_{Clk}$		$BR_Range2 \times 2 \mu\text{s}/T_{Clk}$	kBit/s	
		BR_Range3		5.6		10.0	5.6		10.0	$BR_Range3 \times 2 \mu\text{s}/T_{Clk}$		$BR_Range3 \times 2 \mu\text{s}/T_{Clk}$	kBit/s	

*) Type means: A = 100% tested, B = 100% correlation tested, C = Characterized on samples, D = Design parameter

18. Electrical Characteristics ATA5724, ATA5728 (Continued)

All parameters refer to GND, $T_{amb} = -40^{\circ}\text{C}$ to $+105^{\circ}\text{C}$, $V_S = 4.5\text{V}$ to 5.5V , $f_0 = 433.92\text{ MHz}$ and $f_0 = 868.3\text{ MHz}$ unless otherwise specified (For typical values: $V_S = 5\text{V}$, $T_{amb} = 25^{\circ}\text{C}$).

No.	Parameter	Test Conditions	Symbol	$f_{RF} = 433.92\text{ MHz}$ 13.52875 MHz Oscillator			$f_{RF} = 868.3\text{ MHz}$, 13.55234 MHz Oscillator			Variable Oscillator			Unit	Type*
				Min.	Typ.	Max.	Min.	Typ.	Max.	Min.	Typ.	Max.		
8.3	Minimum time period between edges at pin DATA (see Figure 4-2 and Figure 8-8, Figure 8-9) (With the exception of parameter T_{Pulse})	BR_Range =	t_{DATA_min}											A
		BR_Range0		165.5	165.5	165.3	165.3	$10 \times T_{XClk}$		$10 \times T_{XClk}$	μs			
		BR_Range1		82.8	82.8	82.6	82.6	$10 \times T_{XClk}$		$10 \times T_{XClk}$	μs			
		BR_Range2		41.4	41.4	41.3	41.3	$10 \times T_{XClk}$		$10 \times T_{XClk}$	μs			
		BR_Range3	20.7	20.7	20.6	20.6	$10 \times T_{XClk}$		$10 \times T_{XClk}$	μs				
8.4	Maximum Low period at pin DATA (see Figure 4-2)	BR_Range =	$t_{DATA_L_max}$											A
		BR_Range0		2152	2152	2148	2148	$130 \times T_{XClk}$		$130 \times T_{XClk}$	μs			
		BR_Range1		1076	1076	1074	1074	$130 \times T_{XClk}$		$130 \times T_{XClk}$	μs			
		BR_Range2		538	538	537	537	$130 \times T_{XClk}$		$130 \times T_{XClk}$	μs			
		BR_Range3	269	269	268.5	268.5	$130 \times T_{XClk}$		$130 \times T_{XClk}$	μs				
8.5	Delay to activate the start-up mode (see Figure 8-12)		Ton1	19.6		21.7	19.6		21.7	$9.5 \times T_{Clk}$		$10.5 \times T_{Clk}$	μs	A
8.6	OFF command at pin POLLING/_ON (see Figure 8-11)		Ton2	16.5			16.5			$8 \times T_{Clk}$			μs	A
8.7	Delay to activate the sleep mode (see Figure 8-11)		Ton3	17.6		19.6	17.6		19.6	$8.5 \times T_{Clk}$		$9.5 \times T_{Clk}$	μs	A
8.8	Pulse on pin DATA at the end of a data stream (see Figure 10-3)	BR_Range =	T_{Pulse}											C
		BR_Range0		16.557	16.557	16.528	16.528	$8 \times T_{Clk}$		$8 \times T_{Clk}$	μs			
		BR_Range1		8.278	8.278	8.264	8.264	$4 \times T_{Clk}$		$4 \times T_{Clk}$	μs			
		BR_Range2		4.139	4.139	4.132	4.132	$2 \times T_{Clk}$		$2 \times T_{Clk}$	μs			
		BR_Range3	2.069	2.069	2.066	2.066	$1 \times T_{Clk}$		$1 \times T_{Clk}$	μs				

*) Type means: A = 100% tested, B = 100% correlation tested, C = Characterized on samples, D = Design parameter

18. Electrical Characteristics ATA5724, ATA5728 (Continued)

All parameters refer to GND, T_{amb} = -40°C to +105°C, V_S = 4.5V to 5.5V, f₀ = 433.92 MHz and f₀ = 868.3 MHz unless otherwise specified (For typical values: V_S = 5V, T_{amb} = 25°C).

No.	Parameter	Test Conditions	Symbol	f _{RF} = 433.92 MHz 13.52875 MHz Oscillator			f _{RF} = 868.3 MHz, 13.55234 MHz Oscillator			Variable Oscillator			Unit	Type*
				Min.	Typ.	Max.	Min.	Typ.	Max.	Min.	Typ.	Max.		
9 Configuration of the Receiver (see Figure 12-1 and Figure 13-1)														
9.1	Frequency of the reset marker	Frequency is stable within 50 ms after POR	f _{RM}	117.9		117.9	118.2		118.2	1/ (4096 × T _{Clk})		1/ (4096 × T _{Clk})	Hz	A
9.2	Programming start pulse	BR_Range = BR_Range0 BR_Range1 BR_Range2 BR_Range3 after POR	t1	3361 2276 1734 1463 16425		11656 11656 11656 11656	3355 2272 1731 1460		11636 11636 11636 11636	1624 × T _{Clk} 1100 × T _{Clk} 838 × T _{Clk} 707 × T _{Clk} 7936 × T _{Clk}		5632 × T _{Clk} 5632 × T _{Clk} 5632 × T _{Clk} 5632 × T _{Clk}	μs μs μs μs	A
9.3	Programming delay period		t2	796		798	794		796	384.5 × T _{Clk}		385.5 × T _{Clk}	μs	A
9.4	Synchronization pulse		t3	265		265	264		264	128 × T _{Clk}		128 × T _{Clk}	μs	A
9.5	Delay until of the program window starts		t4	131		131	131		131	63.5 × T _{Clk}		63.5 × T _{Clk}	μs	A
9.6	Programming window		t5	530		530	529		529	256 × T _{Clk}		256 × T _{Clk}	μs	A
9.7	Time frame of a bit		t6	1060		1060	1058		1058	512 × T _{Clk}		512 × T _{Clk}	μs	A
9.8	Programming pulse		t7	132		530	132		529	64 × T _{Clk}		256 × T _{Clk}	μs	C
9.9	Equivalent acknowledge pulse: E_Ack		t8	265		265	264		264	128 × T _{Clk}		128 × T _{Clk}	μs	A
9.10	Equivalent time window		t9	534		534	533		533	258 × T _{Clk}		258 × T _{Clk}	μs	A
9.11	OFF-bit programming window		t10	930		930	929		929	449.5 × T _{Clk}		449.5 × T _{Clk}	μs	A
10 Data Clock (see Figure 9-1 and Figure 9-6)														
10.1	Minimum delay time between edge at DATA and DATA_CLK	BR_Range = BR_Range0 BR_Range1 BR_Range2 BR_Range3	t _{Delay2}	0 0 0 0		16.557 8.278 4.139 2.069	0 0 0 0		16.528 8.264 4.132 2.066	0 0 0 0		1 × T _{XClk} 1 × T _{XClk} 1 × T _{XClk} 1 × T _{XClk}	μs μs μs μs	C
10.2	Pulse width of negative pulse at pin DATA_CLK	BR_Range = BR_Range0 BR_Range1 BR_Range2 BR_Range3	t _{P_DATA_CLK}	66.2 33.1 16.5 8.3		62.2 33.1 16.5 8.3	66.1 33.0 16.5 8.25		66.1 33.0 16.5 8.25	4 × T _{XClk} 4 × T _{XClk} 4 × T _{XClk} 4 × T _{XClk}		4 × T _{XClk} 4 × T _{XClk} 4 × T _{XClk} 4 × T _{XClk}	μs μs μs μs	A

*) Type means: A = 100% tested, B = 100% correlation tested, C = Characterized on samples, D = Design parameter

19. Electrical Characteristics ATA5723, ATA5724, ATA5728 (Continued)

All parameters refer to GND, $T_{amb} = -40^{\circ}\text{C}$ to $+105^{\circ}\text{C}$, $V_S = 4.5\text{V}$ to 5.5V , $f_0 = 868.3\text{ MHz}$, $f_0 = 433.92\text{ MHz}$ and $f_0 = 315\text{ MHz}$, unless otherwise specified. (For typical values: $V_S = 5\text{V}$, $T_{amb} = 25^{\circ}\text{C}$)

No.	Parameters	Test Conditions	Symbol	Min.	Typ.	Max.	Unit	Type*
13.6	Static capacitance at pin XTAL1 to GND	Parameter of the supplied crystal and board parasitics	C_{L1}	-5%	18	+5%	pF	B
13.7	Static capacitance at pin XTAL2 to GND	Parameter of the supplied crystal and board parasitics	C_{L2}	-5%	18	+5%	pF	B
13.8	Crystal series resistor R_m at start-up	$C_0 < 1.8\text{ pF}$, $C_L = 9\text{ pF}$ $f_{XTAL} = 14.71875\text{ MHz}$			1.5		$k\Omega$	B
		$C_0 < 2.0\text{ pF}$, $C_L = 9\text{ pF}$ $f_{XTAL} = 13.52875\text{ MHz}$ $f_{XTAL} = 13.55234\text{ MHz}$			1.5		$k\Omega$	B
14 Analog Signal Processing (Input Matched According to Figure 14-1 on page 32 Referred to RFIN)								
14.1	Input sensitivity ASK 300 kHz IF Filter (ATA5723/ATA5724)	ASK (level of carrier) BER $\leq 10^{-3}$, 100% Mod $f_{in} = 315\text{ MHz}/433.92\text{ MHz}$ $V_S = 5\text{V}$, $T_{amb} = 25^{\circ}\text{C}$ $f_{IF} = 987\text{ kHz}$	P_{Ref_ASK}					
		BR_Range0		-111	-113	-115	dBm	B
		BR_Range1		-109.5	-111.5	-113.5	dBm	B
		BR_Range2		-109	-111	-113	dBm	B
14.2	Input sensitivity ASK 600 kHz IF Filter (ATA5728)	ASK (level of carrier) BER $\leq 10^{-3}$, 100% Mod $f_{in} = 868.3\text{ MHz}$ $V_S = 5\text{V}$, $T_{amb} = 25^{\circ}\text{C}$ $f_{IF} = 948\text{ kHz}$	P_{Ref_ASK}					
		BR_Range0		-109	-111	-113	dBm	B
		BR_Range1		-107.5	-109.5	-111.5	dBm	B
		BR_Range2		-107	-109	-111	dBm	B
14.3	Sensitivity variation ASK for the full operating range compared to $T_{amb} = 25^{\circ}\text{C}$, $V_S = 5\text{V}$ (ATA5723/ATA5724/ATA5728)	300 kHz and 600 kHz $f_{in} = 315\text{ MHz}/433.92\text{ MHz}/868.3\text{ MHz}$ $P_{ASK} = P_{Ref_ASK} + \Delta P_{Ref}$	ΔP_{Ref}	+2.5		-1.5	dB	B
		300 kHz version (ATA5723/ATA5724) $f_{in} = 315\text{ MHz}/433.92\text{ MHz}$ $f_{IF} = 987\text{ kHz}$ $f_{IF} = -110\text{ kHz}$ to $+110\text{ kHz}$ $f_{IF} = -140\text{ kHz}$ to $+140\text{ kHz}$ $P_{ASK} = P_{Ref_ASK} + \Delta P_{Ref}$		+5.5		-1.5	dB	B
				+7.5		-1.5	dB	B
				600 kHz version (ATA5728) $f_{in} = 868.3\text{ MHz}$ $f_{IF} = 948\text{ kHz}$ $f_{IF} = -210\text{ kHz}$ to $+210\text{ kHz}$ $f_{IF} = -270\text{ kHz}$ to $+270\text{ kHz}$ $P_{ASK} = P_{Ref_ASK} + \Delta P_{Ref}$	+5.5		-1.5	dB
+7.5		-1.5	dB		B			

*) Type means: A = 100% tested, B = 100% correlation tested, C = Characterized on samples, D = Design parameter

19. Electrical Characteristics ATA5723, ATA5724, ATA5728 (Continued)

All parameters refer to GND, $T_{amb} = -40^{\circ}\text{C}$ to $+105^{\circ}\text{C}$, $V_S = 4.5\text{V}$ to 5.5V , $f_0 = 868.3\text{ MHz}$, $f_0 = 433.92\text{ MHz}$ and $f_0 = 315\text{ MHz}$, unless otherwise specified. (For typical values: $V_S = 5\text{V}$, $T_{amb} = 25^{\circ}\text{C}$)

No.	Parameters	Test Conditions	Symbol	Min.	Typ.	Max.	Unit	Type*
14.5	Input sensitivity FSK 300 kHz IF filter (ATA5723/ATA5724)	$BER \leq 10^{-3}$ $f_{in} = 315\text{ MHz}/433.92\text{ MHz}$ $V_S = 5\text{V}$, $T_{amb} = 25^{\circ}\text{C}$ $f_{IF} = 987\text{ kHz}$						
		BR_Range0 $df = \pm 16\text{ kHz}$ $df = \pm 10\text{ kHz to } \pm 30\text{ kHz}$	P_{Ref_FSK}	-104 -102	-107	-108.5 -108.5	dBm dBm	B
		BR_Range1 $df = \pm 16\text{ kHz}$ $df = \pm 10\text{ kHz to } \pm 30\text{ kHz}$	P_{Ref_FSK}	-102 -100	-105	-106.5 -106.5	dBm dBm	B
		BR_Range2 $df = \pm 16\text{ kHz}$ $df = \pm 10\text{ kHz to } \pm 30\text{ kHz}$	P_{Ref_FSK}	-100.5 -98.5	-103.5	-105 -105	dBm dBm	B
		BR_Range3 $df = \pm 16\text{ kHz}$ $df = \pm 10\text{ kHz to } \pm 30\text{ kHz}$	P_{Ref_FSK}	-98.5 -96.5	-101.5	-103 -103	dBm dBm	B
14.6	Input sensitivity FSK 600 kHz IF filter (ATA5728)	$BER \leq 10^{-3}$ $f_{in} = 868.3\text{ MHz}$ $V_S = 5\text{V}$, $T_{amb} = 25^{\circ}\text{C}$ $f_{IF} = 948\text{ kHz}$						
		BR_Range0 $df = \pm 16\text{ kHz to } \pm 28\text{ kHz}$ $df = \pm 10\text{ kHz to } \pm 100\text{ kHz}$	P_{Ref_FSK}	-102 -100	-105	-106.5 -106.5	dBm dBm	B
		BR_Range1 $df = \pm 16\text{ kHz } \pm 28\text{ kHz}$ $df = \pm 10\text{ kHz to } \pm 100\text{ kHz}$	P_{Ref_FSK}	-100 -98	-103	-104.5 -104.5	dBm dBm	B
		BR_Range2 $df = \pm 18\text{ kHz } \pm 31\text{ kHz}$ $df = \pm 13\text{ kHz to } \pm 100\text{ kHz}$	P_{Ref_FSK}	-98.5 -96.5	-101.5	-103 -103	dBm dBm	B
		BR_Range3 $df = \pm 25\text{ kHz } \pm 44\text{ kHz}$ $df = \pm 20\text{ kHz to } \pm 100\text{ kHz}$	P_{Ref_FSK}	-96.5 -94.5	-99.5	-101 -101	dBm dBm	B
14.7	Sensitivity variation FSK for the full operating range compared to $T_{amb} = 25^{\circ}\text{C}$, $V_S = 5\text{V}$ (ATA5723/ATA5724/ATA5728)	300 kHz and 600 kHz versions $f_{in} = 315\text{ MHz}/433.92\text{ MHz}/868.3\text{ MHz}$ $P_{FSK} = P_{Ref_FSK} + \Delta P_{Ref}$	ΔP_{Ref}	+3		-1.5	dB	B

*) Type means: A = 100% tested, B = 100% correlation tested, C = Characterized on samples, D = Design parameter

19. Electrical Characteristics ATA5723, ATA5724, ATA5728 (Continued)

All parameters refer to GND, $T_{amb} = -40^{\circ}\text{C}$ to $+105^{\circ}\text{C}$, $V_S = 4.5\text{V}$ to 5.5V , $f_0 = 868.3\text{ MHz}$, $f_0 = 433.92\text{ MHz}$ and $f_0 = 315\text{ MHz}$, unless otherwise specified. (For typical values: $V_S = 5\text{V}$, $T_{amb} = 25^{\circ}\text{C}$)

No.	Parameters	Test Conditions	Symbol	Min.	Typ.	Max.	Unit	Type*
14.8	Sensitivity variation FSK for the full operating range including IF filter compared to $T_{amb} = 25^{\circ}\text{C}$, $V_S = 5\text{V}$	300 kHz version (ATA5723/ATA5724) $f_{in} = 315\text{ MHz}/433.92\text{ MHz}$ $f_{IF} = 987\text{ kHz}$ $f_{IF} = -110\text{ kHz}$ to $+110\text{ kHz}$ $f_{IF} = -140\text{ kHz}$ to $+140\text{ kHz}$ $f_{IF} = -180\text{ kHz}$ to $+180\text{ kHz}$ $P_{FSK} = P_{Ref_FSK} + \Delta P_{Ref}$	ΔP_{Ref}	+6		-2	dB	B
		+8			-2			
		600 kHz version (ATA5728) $f_{in} = 868.3\text{ MHz}$ $f_{IF} = 948\text{ kHz}$ $f_{IF} = -150\text{ kHz}$ to $+150\text{ kHz}$ $f_{IF} = -200\text{ kHz}$ to $+200\text{ kHz}$ $f_{IF} = -260\text{ kHz}$ to $+150\text{ kHz}$ $P_{FSK} = P_{Ref_FSK} + \Delta P_{Ref}$	ΔP_{Ref}	+6		-2	dB	B
		+8			-2			
14.9	S/N ratio to suppress in-band noise signals. Noise signals may have any modulation scheme	ASK mode	SNR_{ASK}		10	12	dB	C
		FSK mode	SNR_{FSK}		2	3	dB	
14.10	Dynamic range RSSI amplifier		ΔR_{RSSI}		60		dB	A
14.11	RSSI output voltage range		V_{RSSI}	1		3.5	V	A
14.12	RSSI gain		G_{RSSI}		20		mV/dB	A
14.13	Lower cut-off frequency of the data filter	$f_{cu_DF} = \frac{1}{2 \times \pi \times 30\text{ k}\Omega \times \text{CDEM}}$ CDEM = 33 nF	f_{cu_DF}	0.11	0.16	0.20	kHz	B
14.14	Recommended CDEM for best performance	BR_Range0 (default) BR_Range1 BR_Range2 BR_Range3	CDEM		39 22 12 8.2		nF nF nF nF	C
14.15	Edge-to-edge time period of the input data signal for full sensitivity	BR_Range0 (default) BR_Range1 BR_Range2 BR_Range3	t_{ee_sig}	270 156 89 50		1000 560 320 180	ms ms ms ms	C
14.16	Upper cut-off frequency data filter	Upper cut-off frequency programmable in 4 ranges using a serial mode word BR_Range0 (default) BR_Range1 BR_Range2 BR_Range3	f_u	2.8 4.8 8.0 15.0	3.4 6.0 10.0 19.0	4.0 7.2 12.0 23.0	kHz kHz kHz kHz	B
14.17	Reduced sensitivity	300 kHz version (ATA5723/ATA5724) R_{Sense} connected from pin SENS to V_S , input matched according to Figure 14-1 "Application Circuit", $f_{in} = 315\text{ MHz}/433.92\text{ MHz}$, $V_S = 5\text{V}$, $T_{amb} = +25^{\circ}\text{C}$					dBm (peak level)	
		$R_{Sense} = 56\text{ k}\Omega$	P_{Ref_Red}	-74	-79	-83	dBm	B
		$R_{Sense} = 100\text{ k}\Omega$	P_{Ref_Red}	-83	-88	-93	dBm	B

*) Type means: A = 100% tested, B = 100% correlation tested, C = Characterized on samples, D = Design parameter

19. Electrical Characteristics ATA5723, ATA5724, ATA5728 (Continued)

All parameters refer to GND, $T_{amb} = -40^{\circ}\text{C}$ to $+105^{\circ}\text{C}$, $V_S = 4.5\text{V}$ to 5.5V , $f_0 = 868.3\text{ MHz}$, $f_0 = 433.92\text{ MHz}$ and $f_0 = 315\text{ MHz}$, unless otherwise specified. (For typical values: $V_S = 5\text{V}$, $T_{amb} = 25^{\circ}\text{C}$)

No.	Parameters	Test Conditions	Symbol	Min.	Typ.	Max.	Unit	Type*	
14.18	Reduced sensitivity	600 kHz version (ATA5728) R_{Sense} connected from pin SENS to V_S , input matched according to Figure 14-1 "Application Circuit, $f_{in} = 868.3\text{ MHz}$, $V_S = 5\text{V}$, $T_{amb} = +25^{\circ}\text{C}$					dBm (peak level)		
		$R_{Sense} = 56\text{ k}\Omega$	P_{Ref_Red}	-63	-68	-73		dBm	B
		$R_{Sense} = 100\text{ k}\Omega$	P_{Ref_Red}	-72	-77	-82		dBm	B
14.19	Reduced sensitivity variation over full operating range	$R_{Sense} = 56\text{ k}\Omega$ $R_{Sense} = 100\text{ k}\Omega$ $P_{Red} = P_{Ref_Red} + \Delta P_{Red}$	ΔP_{Red}	5 5	0 0	0 0	dB dB	C	
14.20	Reduced sensitivity variation for different values of R_{Sense}	Values relative to $R_{Sense} = 56\text{ k}\Omega$ $R_{Sense} = 56\text{ k}\Omega$ $R_{Sense} = 68\text{ k}\Omega$ $R_{Sense} = 82\text{ k}\Omega$ $R_{Sense} = 100\text{ k}\Omega$	ΔP_{Red}		0 -3.5 -6.0 -9.0		dB dB dB dB	C	
14.21	Threshold voltage for reset		$V_{ThRESET}$	1.95	2.8	3.75	V	A	
15	Digital Ports								
15.1	Data output	$I_{ol} \leq 12\text{ mA}$ $I_{ol} = 2\text{ mA}$ $V_{oh} = 20\text{V}$ $V_{ol} = 0.8\text{V}$ to 20V $V_{oh} = 0\text{V}$ to 20V	V_{ol} V_{oh} I_{qu} I_{ol_lim} t_{amb_sc}	13	0.35 0.08	0.8 0.3 20 20	V V V μA mA $^{\circ}\text{C}$	A	
	- Saturation voltage Low								
15.1	Data input		V_{ll} V_{ich}	$0.65 \times V_S$		$0.35 \times V_S$	V V	A	
	- Input voltage Low								
15.1	- Input voltage High							A	
	- max voltage at pin DATA								
15.1	- quiescent current							A	
	- short-circuit current								
15.1	- ambient temp. in case of permanent short-circuit							A	
15.2	DATA_CLK output	IDATA_CLK = 1mA IDATA_CLK = -1mA	V_{ol} V_{oh}	$V_S - 0.4\text{V}$	0.1 $V_S - 0.15\text{V}$	0.4	V V	A	
	- Saturation voltage Low								
	- Saturation voltage High								
15.3	IC_ACTIVE output	IIC_ACTIVE = 1 mA IIC_ACTIVE = -1 mA	V_{ol} V_{oh}	$V_S - 0.4\text{V}$	0.1 $V_S - 0.15\text{V}$	0.4	V V	A	
	- Saturation voltage Low								
	- Saturation voltage High								
15.4	POLLING/_ON input	Receiving mode Polling mode	V_{ll} V_{lh}	$0.8 \times V_S$		$0.2 \times V_S$	V V	A	
	- Low level input voltage								
	- High level input voltage								
15.5	MODE pin	Test input must always be set to High	V_{lh}	$0.8 \times V_S$			V	A	
	- High level input voltage								
15.6	TEST 1 pin	Test input must always be set to Low	V_{ll}			$0.2 \times V_S$	V	A	
	- Low level input voltage								

*) Type means: A = 100% tested, B = 100% correlation tested, C = Characterized on samples, D = Design parameter

20. Ordering Information

Extended Type Number	Package	Remarks
ATA5723P3-TKQY	SSO20	315 MHz version
ATA5724P3-TKQY	SSO20	433 MHz version
ATA5728P6-TKQY	SSO20	868 MHz version

21. Package Information

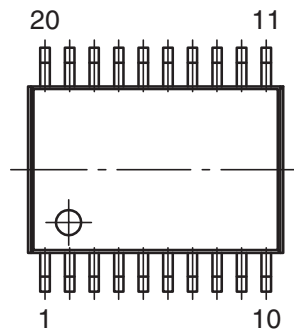
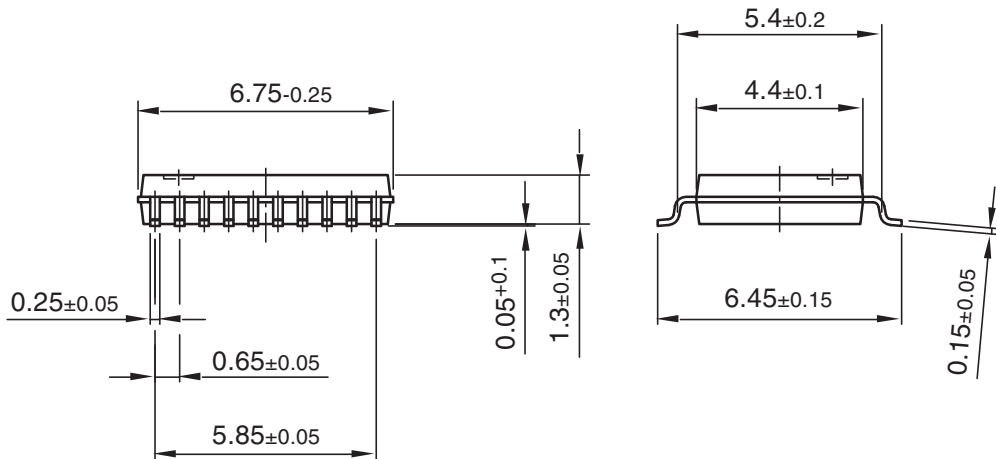

Package: SSO20
Dimensions in mm

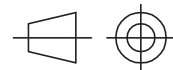

technical drawings
according to DIN
specifications

Drawing-No.: 6.543-5056.01-4

Issue: 1; 10.03.04



Headquarters

Atmel Corporation
2325 Orchard Parkway
San Jose, CA 95131
USA
Tel: 1(408) 441-0311
Fax: 1(408) 487-2600

International

Atmel Asia
Room 1219
Chinachem Golden Plaza
77 Mody Road Tsimshatsui
East Kowloon
Hong Kong
Tel: (852) 2721-9778
Fax: (852) 2722-1369

Atmel Europe
Le Krebs
8, Rue Jean-Pierre Timbaud
BP 309
78054
Saint-Quentin-en-Yvelines Cedex
France
Tel: (33) 1-30-60-70-00
Fax: (33) 1-30-60-71-11

Atmel Japan
9F, Tonetsu Shinkawa Bldg.
1-24-8 Shinkawa
Chuo-ku, Tokyo 104-0033
Japan
Tel: (81) 3-3523-3551
Fax: (81) 3-3523-7581

Product Contact

Web Site
www.atmel.com

Technical Support
auto_control@atmel.com

Sales Contact
www.atmel.com/contacts

Literature Requests
www.atmel.com/literature

Disclaimer: The information in this document is provided in connection with Atmel products. No license, express or implied, by estoppel or otherwise, to any intellectual property right is granted by this document or in connection with the sale of Atmel products. **EXCEPT AS SET FORTH IN ATMEL'S TERMS AND CONDITIONS OF SALE LOCATED ON ATMEL'S WEB SITE, ATMEL ASSUMES NO LIABILITY WHATSOEVER AND DISCLAIMS ANY EXPRESS, IMPLIED OR STATUTORY WARRANTY RELATING TO ITS PRODUCTS INCLUDING, BUT NOT LIMITED TO, THE IMPLIED WARRANTY OF MERCHANTABILITY, FITNESS FOR A PARTICULAR PURPOSE, OR NON-INFRINGEMENT. IN NO EVENT SHALL ATMEL BE LIABLE FOR ANY DIRECT, INDIRECT, CONSEQUENTIAL, PUNITIVE, SPECIAL OR INCIDENTAL DAMAGES (INCLUDING, WITHOUT LIMITATION, DAMAGES FOR LOSS OF PROFITS, BUSINESS INTERRUPTION, OR LOSS OF INFORMATION) ARISING OUT OF THE USE OR INABILITY TO USE THIS DOCUMENT, EVEN IF ATMEL HAS BEEN ADVISED OF THE POSSIBILITY OF SUCH DAMAGES.** Atmel makes no representations or warranties with respect to the accuracy or completeness of the contents of this document and reserves the right to make changes to specifications and product descriptions at any time without notice. Atmel does not make any commitment to update the information contained herein. Unless specifically provided otherwise, Atmel products are not suitable for, and shall not be used in, automotive applications. Atmel's products are not intended, authorized, or warranted for use as components in applications intended to support or sustain life.

© 2008 Atmel Corporation. All rights reserved. Atmel®, logo and combinations thereof, and others are registered trademarks or trademarks of Atmel Corporation or its subsidiaries. Other terms and product names may be trademarks of others.

Looking for pricing, stock, or lifecycle information?

Click below to explore more details on WIN SOURCE:

- ⊖ [View ATA5724P3-TKQY 19 on WIN SOURCE](#)
- ⊖ [Microchip Technology Information](#)

Optimize Your Supply Chain with WIN SOURCE Solutions

- ✓ Global Sourcing Solution
- ✓ Obsolete Management
- ✓ Cost Control Management
- ✓ Shortage Management
- ✓ Alternative Solution
- ✓ Excess Inventory Management