



**THE DATASHEET OF  
TPD8E003DQDR**



## TPD8E003 8-Channel ESD Protection Diode for Keypad and GPIO

### 1 Features

- IEC 61000-4-2 Level 4 ESD Protection
  - $\pm 12$ -kV Contact Discharge
  - $\pm 15$ -kV Air-Gap Discharge
- IEC 61000-4-5 Surge Protection
  - 3.5-A (8/20  $\mu$ s)
- IO Capacitance: 9 pF (Typical)
- DC Breakdown Voltage: 6 V (Minimum)
- Low Leakage Current: 100 nA (Maximum)
- Industrial Temperature Range:  $-40^{\circ}\text{C}$  to  $85^{\circ}\text{C}$
- Space-Saving, Ultra-Thin, WSON Package

### 2 Applications

- End Equipment
  - Laptops and Desktops
  - IP Phones
- Interfaces
  - Keypads
  - GPIO Headers
  - Touchscreens
  - Low-Speed Memory Interfaces

### 3 Description

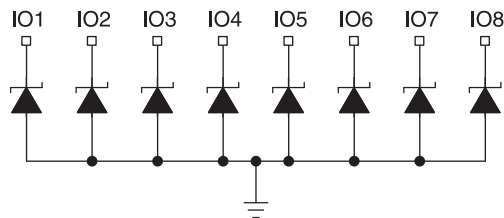
The TPD8E003 device is a unidirectional Transient Voltage Suppressor (TVS) based Electrostatic Discharge (ESD) protection diode array. The TPD8E003 is rated to dissipate ESD strikes above the maximum level specified in the IEC 61000-4-2 international standard (Level 4). This device provides 8 channels of ESD protection in a space-saving WSON package. Typical applications for the TPD8E003 include Keypad, GPIO, resistive touchscreen, and low-speed memory interfaces. Also, see the TPD2E2U06 and TPD4E05U06 for 2- and 4-channel ESD protection solutions, respectively.

#### Device Information<sup>(1)</sup>

PART NUMBER	PACKAGE	BODY SIZE (NOM)
TPD8E003	WSON (8)	1.70 mm x 1.35 mm

(1) For all available packages, see the orderable addendum at the end of the data sheet.

#### Simplified Circuit Schematic



## Table of Contents

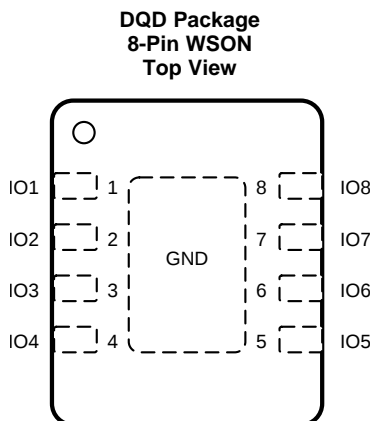
<b>1 Features</b> .....	<b>1</b>	7.3 Feature Description .....	<b>6</b>
<b>2 Applications</b> .....	<b>1</b>	7.4 Device Functional Modes .....	<b>6</b>
<b>3 Description</b> .....	<b>1</b>	<b>8 Application and Implementation</b> .....	<b>7</b>
<b>4 Revision History</b> .....	<b>2</b>	8.1 Application Information .....	<b>7</b>
<b>5 Pin Configuration and Functions</b> .....	<b>3</b>	8.2 Typical Application .....	<b>7</b>
<b>6 Specifications</b> .....	<b>4</b>	<b>9 Power Supply Recommendations</b> .....	<b>9</b>
6.1 Absolute Maximum Ratings .....	<b>4</b>	<b>10 Layout</b> .....	<b>9</b>
6.2 ESD Ratings .....	<b>4</b>	10.1 Layout Guidelines .....	<b>9</b>
6.3 ESD Ratings – Surge Protection .....	<b>4</b>	10.2 Layout Example .....	<b>9</b>
6.4 Recommended Operating Conditions .....	<b>4</b>	<b>11 Device and Documentation Support</b> .....	<b>11</b>
6.5 Thermal Information .....	<b>4</b>	11.1 Community Resources .....	<b>11</b>
6.6 Electrical Characteristics .....	<b>5</b>	11.2 Trademarks .....	<b>11</b>
6.7 Typical Characteristics .....	<b>5</b>	11.3 Electrostatic Discharge Caution .....	<b>11</b>
<b>7 Detailed Description</b> .....	<b>6</b>	11.4 Glossary .....	<b>11</b>
7.1 Overview .....	<b>6</b>	<b>12 Mechanical, Packaging, and Orderable Information</b> .....	<b>11</b>
7.2 Functional Block Diagram .....	<b>6</b>		

## 4 Revision History

NOTE: Page numbers for previous revisions may differ from page numbers in the current version.

<b>Changes from Revision A (September 2010) to Revision B</b>	<b>Page</b>
• Added <i>ESD Ratings</i> tables, <i>Feature Description</i> section, <i>Device Functional Modes</i> , <i>Application and Implementation</i> section, <i>Power Supply Recommendations</i> section, <i>Layout</i> section, <i>Device and Documentation Support</i> section, and <i>Mechanical, Packaging, and Orderable Information</i> section .....	<b>1</b>
• Deleted <i>Ordering Information</i> table; see POA at the end of the data sheet .....	<b>1</b>

## 5 Pin Configuration and Functions



### Pin Functions

PIN		TYPE <sup>(1)</sup>	DESCRIPTION
NO.	NAME		
1	IO1	I/O	ESD protected channel
2	IO2	I/O	ESD protected channel
3	IO3	I/O	ESD protected channel
4	IO4	I/O	ESD protected channel
5	IO5	I/O	ESD protected channel
6	IO6	I/O	ESD protected channel
7	IO7	I/O	ESD protected channel
8	IO8	I/O	ESD protected channel
GND	GND	G	Connect to ground

(1) G = Ground, I = Input, O = Output

## 6 Specifications

### 6.1 Absolute Maximum Ratings

over operating free-air temperature range (unless otherwise noted)<sup>(1)</sup>

	MIN	MAX	UNIT
IO voltage tolerance (IO pins)		6	V
Peak pulse power (tp = 8/20 μs)		55	W
Peak pulse current (tp = 8/20 μs)		3.5	A
T <sub>A</sub> Operating free-air temperature	-40	85	°C
T <sub>stg</sub> Storage temperature	-55	155	°C

(1) Stresses beyond those listed under *Absolute Maximum Ratings* may cause permanent damage to the device. These are stress ratings only, which do not imply functional operation of the device at these or any other conditions beyond those indicated under *Recommended Operating Conditions*. Exposure to absolute-maximum-rated conditions for extended periods may affect device reliability.

### 6.2 ESD Ratings

	VALUE	UNIT
V <sub>(ESD)</sub> Electrostatic discharge	Human-body model (HBM), per ANSI/ESDA/JEDEC JS-001 <sup>(1)</sup>	±2000
	Charged-device model (CDM), per JEDEC specification JESD22-C101 <sup>(2)</sup>	±1000

(1) JEDEC document JEP155 states that 500-V HBM allows safe manufacturing with a standard ESD control process.

(2) JEDEC document JEP157 states that 250-V CDM allows safe manufacturing with a standard ESD control process.

### 6.3 ESD Ratings – Surge Protection

	VALUE	UNIT
V <sub>(ESD)</sub> Electrostatic discharge	IEC 61000-4-2 contact discharge	±12000
	IEC 61000-4-2 air-gap discharge	±15000

### 6.4 Recommended Operating Conditions

over operating free-air temperature range (unless otherwise noted)

	MIN	NOM	MAX	UNIT
V <sub>IO</sub> Input pin voltage	0		5.5	V
T <sub>A</sub> Operating free-air temperature	-40		85	°C

### 6.5 Thermal Information

THERMAL METRIC <sup>(1)</sup>	TPD8E003	UNIT
	DQD (WSON)	
	8 PINS	
R <sub>θJA</sub> Junction-to-ambient thermal resistance	98.3	°C/W
R <sub>θJC(top)</sub> Junction-to-case (top) thermal resistance	110.3	°C/W
R <sub>θJB</sub> Junction-to-board thermal resistance	42.5	°C/W
Ψ <sub>JT</sub> Junction-to-top characterization parameter	9.2	°C/W
Ψ <sub>JB</sub> Junction-to-board characterization parameter	42.2	°C/W
R <sub>θJC(bot)</sub> Junction-to-case (bottom) thermal resistance	22.0	°C/W

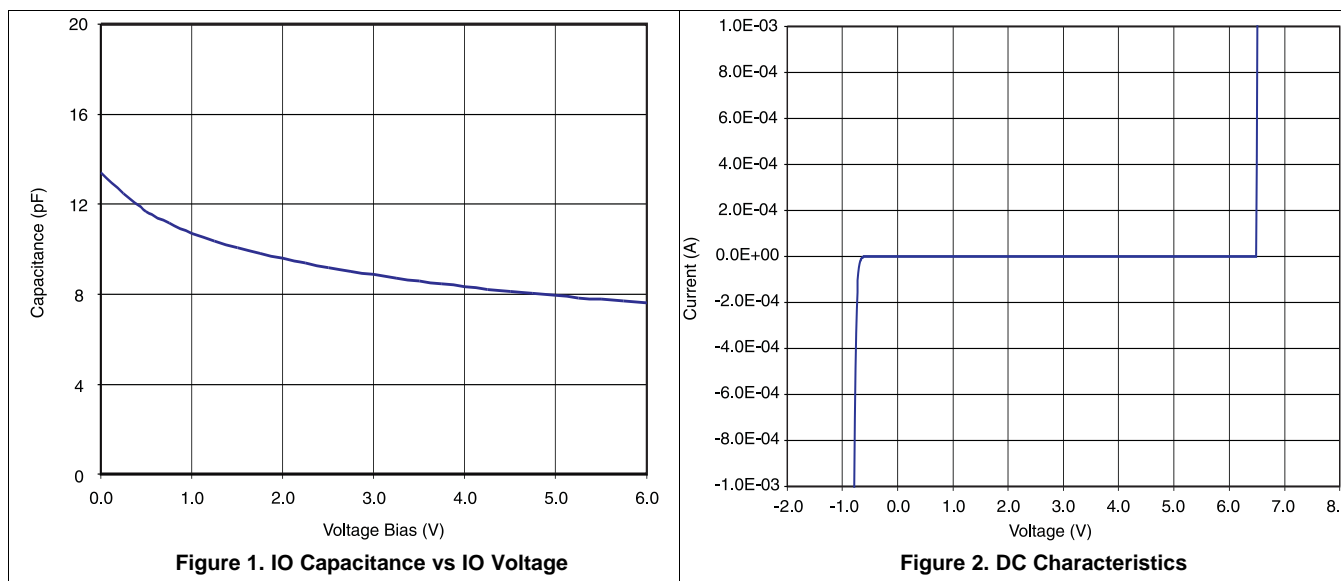
(1) For more information about traditional and new thermal metrics, see the *Semiconductor and IC Package Thermal Metrics* application report, [SPRA953](#).

### 6.6 Electrical Characteristics

over operating free-air temperature range (unless otherwise noted)

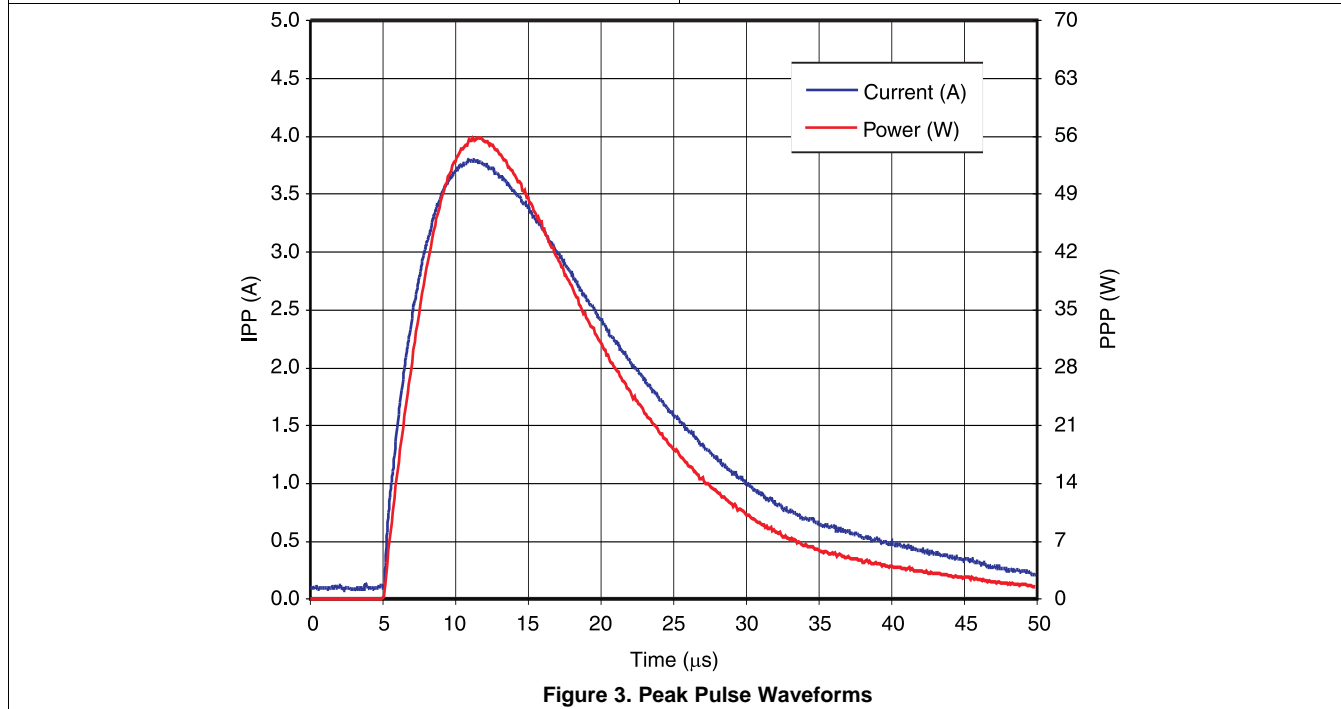
PARAMETER		TEST CONDITION	MIN	TYP	MAX	UNIT
$V_{clamp}$	Clamp voltage	$I_{IO} = 2\text{ A}$ , IO pin-to-ground			10	V
$I_l$	Leakage current	IO pin-to-ground			0.1	$\mu\text{A}$
$C_{IO}$	IO capacitance	$V_{IO} = 2.5\text{ V}$ , IO pins	7	9	12	pF
$\Delta C_{IO}$	Differential line capacitance	$V_{IO} = 2.5\text{ V}$ , between IO pins		0.1		pF
$V_{BR}$	Break-down voltage	$I_{IO} = 1\text{ mA}$	6			V
$R_{dyn}$	Dynamic resistance	$I_{IO} = 1\text{ A}$ , between IO pin and ground		1		$\Omega$

### 6.7 Typical Characteristics



**Figure 1. IO Capacitance vs IO Voltage**

**Figure 2. DC Characteristics**



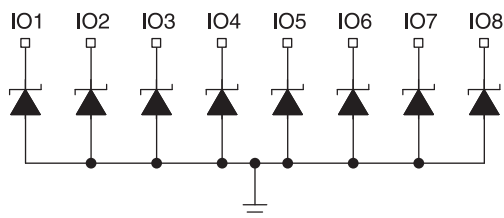
**Figure 3. Peak Pulse Waveforms**

## 7 Detailed Description

### 7.1 Overview

The TPD8E003 is a unidirectional TVS-based, ESD protection diode array. The TPD8E003 is rated to dissipate ESD strikes above the maximum level specified in the IEC 61000-4-2 international standard (Level 4). This device provides 8 channels of ESD protection in a space-saving WSON package.

### 7.2 Functional Block Diagram



### 7.3 Feature Description

#### 7.3.1 IEC 61000-4-2 ESD Protection

The I/O pins can withstand ESD events up to  $\pm 12$ -kV contact and  $\pm 15$ -kV air gap. An ESD/surge clamp diverts the current to ground.

#### 7.3.2 IEC 61000-4-5 Surge Protection

The I/O pins can withstand surge events up to 3.5 A and 55 W (8/20  $\mu$ s waveform). An ESD/surge clamp diverts this current to ground.

#### 7.3.3 IO Capacitance

The capacitance between each I/O pin-to-ground is 9 pF (typical) and 12 pF (maximum).

#### 7.3.4 DC Breakdown Voltage

The DC breakdown voltage of each I/O pin is a minimum of 6 V. This ensures that sensitive equipment is protected from surges above the reverse standoff voltage of 5.5 V.

#### 7.3.5 Low Leakage Current

The I/O pins feature a low leakage current of 100 nA (maximum) with a bias of 2.5 V.

#### 7.3.6 Industrial Temperature Range

This device features an industrial operating range of  $-40^{\circ}\text{C}$  to  $85^{\circ}\text{C}$ .

#### 7.3.7 Space-Saving Package

This device features a space-saving WSON package that puts many channels of ESD in a small form factor.

### 7.4 Device Functional Modes

TPD8E003 is a passive integrated circuit that triggers when voltages are above  $V_{BR}$  or below the lower diodes  $V_f$  ( $-0.6$  V). During ESD events, voltages as high as  $\pm 15$  kV (air) can be directed to ground through the internal diode network. When the voltages on the protected line fall below the trigger levels of TPD8E003 (usually within 10s of nano-seconds) the device reverts to passive.

## 8 Application and Implementation

### NOTE

Information in the following applications sections is not part of the TI component specification, and TI does not warrant its accuracy or completeness. TI's customers are responsible for determining suitability of components for their purposes. Customers should validate and test their design implementation to confirm system functionality.

### 8.1 Application Information

The TPD8E003 offers eight ESD clamp circuits in a space-saving DQD package. When placed near the connector, the TPD8E003 ESD solution offers little or no signal distortion during normal operation due to low IO capacitance and ultra-low leakage current specifications. The TPD8E003 ensures that the core circuitry is protected and the system is functioning properly in the event of an ESD strike.

### 8.2 Typical Application

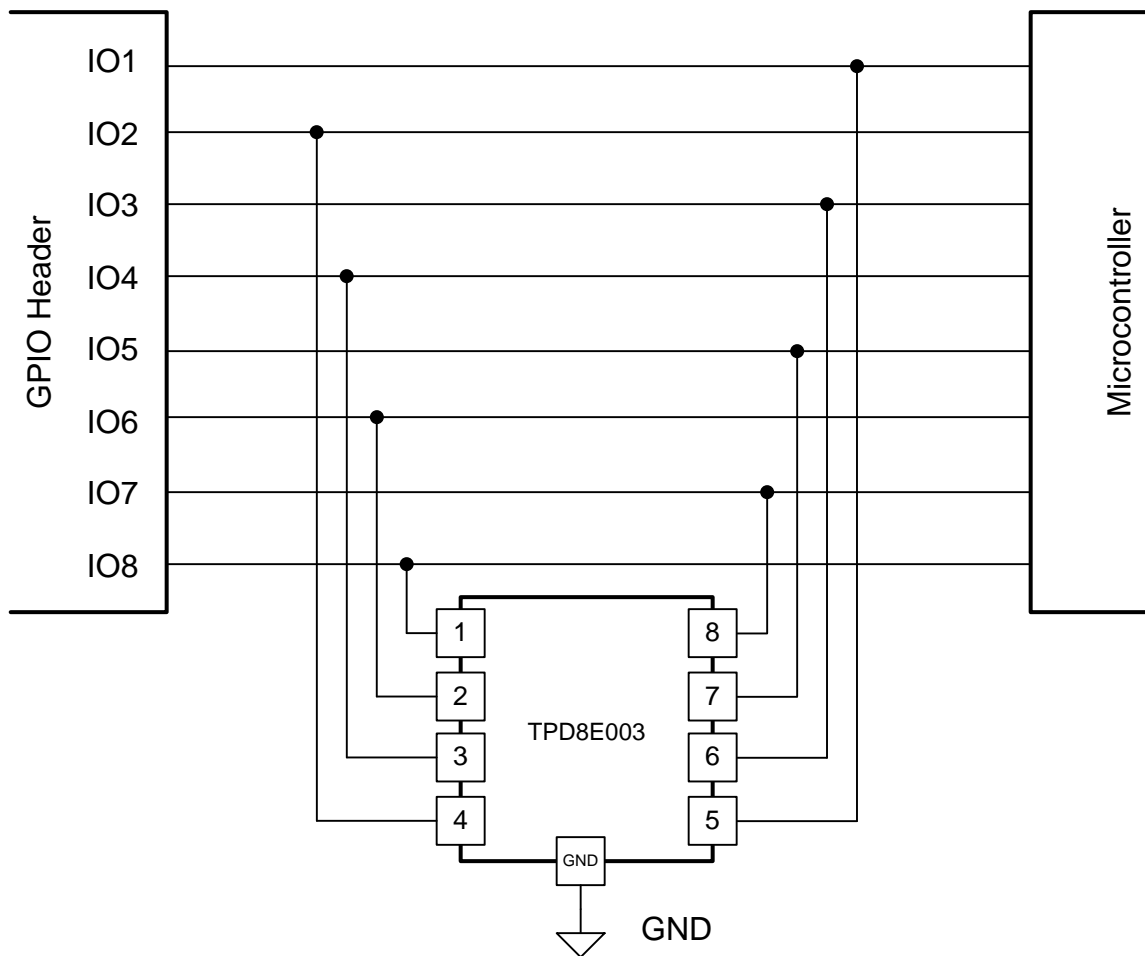


Figure 4. GPIO Header Application

#### 8.2.1 Design Requirements

For this design example, one TPD8E003 is used to protect an 8-pin GPIO header.

Given the example application, the parameters listed in [Table 1](#) are known.

**Table 1. Design Parameters**

PARAMETER	VALUE
Signal Range on Protected Lines	0 V to 5 V
Required Level of IEC ESD Protection	±8kV Contact, ±15kV Air Gap

**8.2.2 Detailed Design Procedure**

To begin the design process, some parameters must be decided upon; the designer must know the following:

- Voltage range of the signal on all protected lines
- Required ESD protection needed

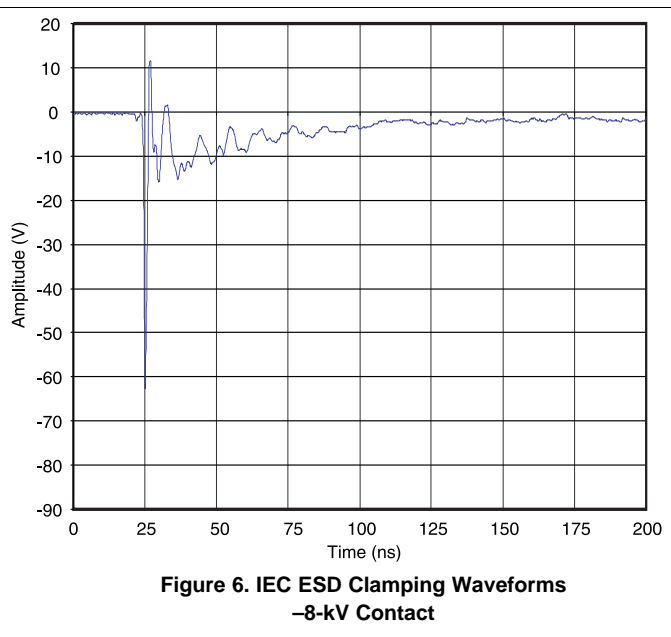
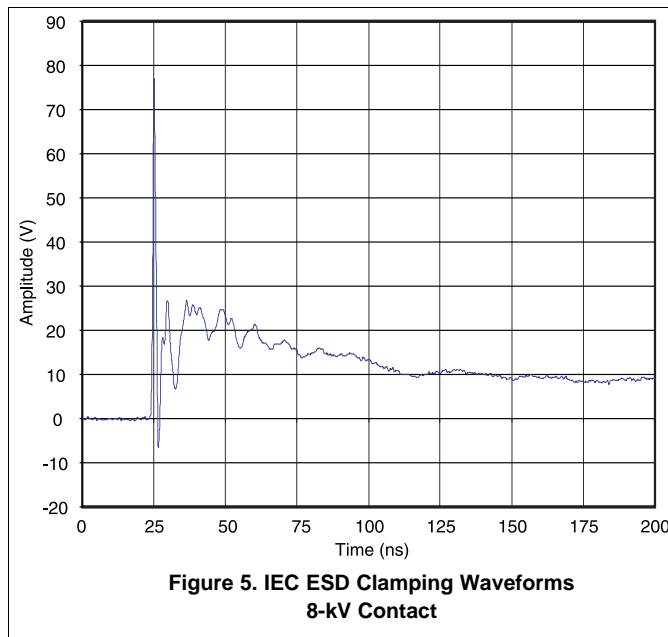
**8.2.2.1 Signal Range**

The TPD8E003 supports signal ranges between 0 V and 5.5 V, which supports the GPIO application.

**8.2.2.2 Required ESD Protection**

The TPD8E003 is rated to withstand up to ±12-kV contact and ±15-kV air gap IEC ESD. This meets the IEC ESD design target with room to spare.

**8.2.3 Application Curves**



## 9 Power Supply Recommendations

This device is a passive ESD protection device and there is no need to power it. Take care making sure that the maximum voltage specifications for each line are not violated.

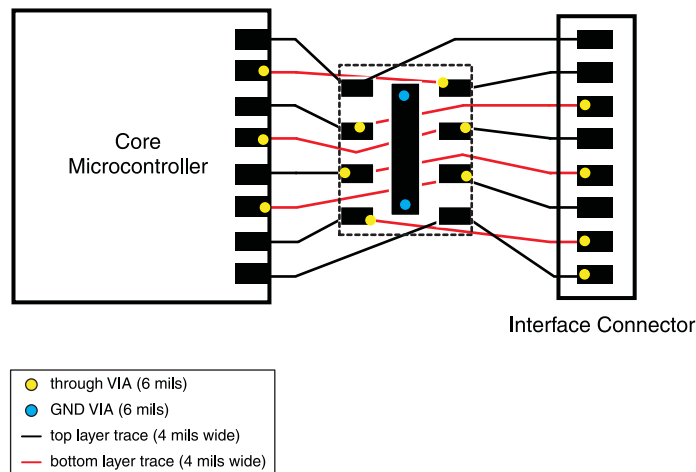
## 10 Layout

### 10.1 Layout Guidelines

For proper operation of the ESD clamps, both during normal function and ESD events, the following layout and design guidelines must be followed:

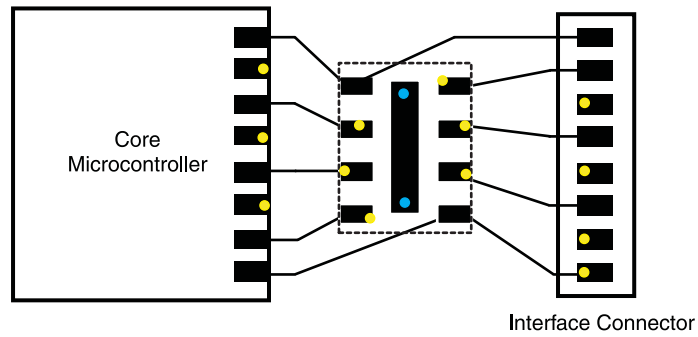
- Place the TPD8E003 solution close to the connector. This allows the TPD8E003 to take away the energy associated with ESD strike before it reaches the internal circuitry of the system board.
- TI recommends employing two signal layers in the printed-circuit board (PCB) to route through the eight ESD clamp terminals of the TPD8E003.
- Ensure that there is proper metallization for the GND vertical interconnect access (VIA). During an ESD event, the in-rush current flows to the system GND plane through the GND VIA. Having a low-impedance path allows the current to flow quickly to GND, effectively building a robust, system-level ESD immunity.
- Place the VIA under the DQD pad in locations that offer maximum flexibility in board routing.
- One common set of guidelines (not restricted to all cases):
  - Trace width: 4 mm
  - VIA diameter: 6 mm
  - DQD package pad dimensions: 8 mm x 12 mm

### 10.2 Layout Example

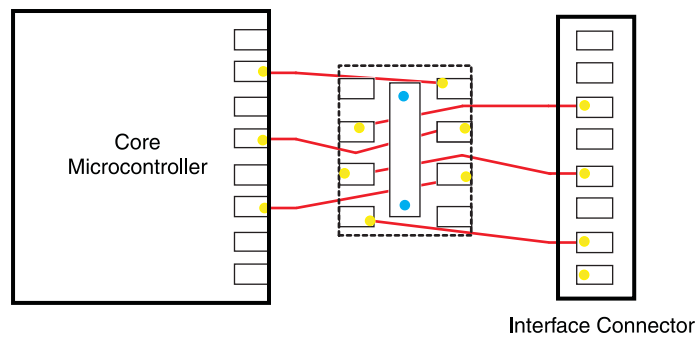


**Figure 7. Board Layout With the TPD8E003DQDR**

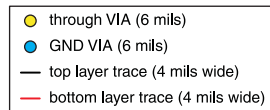
**Layout Example (continued)**



**TOP LAYER ROUTING  
(INCLUDING VIAS)**



**BOTTOM LAYER ROUTING  
(INCLUDING VIAS)**



**Figure 8. Top and Bottom Layer Board Layout With the TPD8E003DQDR**

## 11 Device and Documentation Support

### 11.1 Community Resources

The following links connect to TI community resources. Linked contents are provided "AS IS" by the respective contributors. They do not constitute TI specifications and do not necessarily reflect TI's views; see TI's [Terms of Use](#).

**TI E2E™ Online Community** *TI's Engineer-to-Engineer (E2E) Community*. Created to foster collaboration among engineers. At [e2e.ti.com](http://e2e.ti.com), you can ask questions, share knowledge, explore ideas and help solve problems with fellow engineers.

**Design Support** *TI's Design Support* Quickly find helpful E2E forums along with design support tools and contact information for technical support.

### 11.2 Trademarks

E2E is a trademark of Texas Instruments.  
All other trademarks are the property of their respective owners.

### 11.3 Electrostatic Discharge Caution



These devices have limited built-in ESD protection. The leads should be shorted together or the device placed in conductive foam during storage or handling to prevent electrostatic damage to the MOS gates.

### 11.4 Glossary

[SLYZ022](#) — *TI Glossary*.

This glossary lists and explains terms, acronyms, and definitions.

## 12 Mechanical, Packaging, and Orderable Information

The following pages include mechanical, packaging, and orderable information. This information is the most current data available for the designated devices. This data is subject to change without notice and revision of this document. For browser-based versions of this data sheet, refer to the left-hand navigation.

**PACKAGING INFORMATION**

Orderable Device	Status (1)	Package Type	Package Drawing	Pins	Package Qty	Eco Plan (2)	Lead/Ball Finish (6)	MSL Peak Temp (3)	Op Temp (°C)	Device Marking (4/5)	Samples
TPD8E003DQDR	ACTIVE	WSON	DQD	8	3000	Green (RoHS & no Sb/Br)	CU NIPDAU	Level-1-260C-UNLIM	-40 to 85	(65S ~ 65U)	<a href="#">Samples</a>

(1) The marketing status values are defined as follows:

**ACTIVE:** Product device recommended for new designs.

**LIFEBUY:** TI has announced that the device will be discontinued, and a lifetime-buy period is in effect.

**NRND:** Not recommended for new designs. Device is in production to support existing customers, but TI does not recommend using this part in a new design.

**PREVIEW:** Device has been announced but is not in production. Samples may or may not be available.

**OBSOLETE:** TI has discontinued the production of the device.

(2) **RoHS:** TI defines "RoHS" to mean semiconductor products that are compliant with the current EU RoHS requirements for all 10 RoHS substances, including the requirement that RoHS substance do not exceed 0.1% by weight in homogeneous materials. Where designed to be soldered at high temperatures, "RoHS" products are suitable for use in specified lead-free processes. TI may reference these types of products as "Pb-Free".

**RoHS Exempt:** TI defines "RoHS Exempt" to mean products that contain lead but are compliant with EU RoHS pursuant to a specific EU RoHS exemption.

**Green:** TI defines "Green" to mean the content of Chlorine (Cl) and Bromine (Br) based flame retardants meet JS709B low halogen requirements of <=1000ppm threshold. Antimony trioxide based flame retardants must also meet the <=1000ppm threshold requirement.

(3) MSL, Peak Temp. - The Moisture Sensitivity Level rating according to the JEDEC industry standard classifications, and peak solder temperature.

(4) There may be additional marking, which relates to the logo, the lot trace code information, or the environmental category on the device.

(5) Multiple Device Markings will be inside parentheses. Only one Device Marking contained in parentheses and separated by a "~" will appear on a device. If a line is indented then it is a continuation of the previous line and the two combined represent the entire Device Marking for that device.

(6) Lead/Ball Finish - Orderable Devices may have multiple material finish options. Finish options are separated by a vertical ruled line. Lead/Ball Finish values may wrap to two lines if the finish value exceeds the maximum column width.

**Important Information and Disclaimer:**The information provided on this page represents TI's knowledge and belief as of the date that it is provided. TI bases its knowledge and belief on information provided by third parties, and makes no representation or warranty as to the accuracy of such information. Efforts are underway to better integrate information from third parties. TI has taken and continues to take reasonable steps to provide representative and accurate information but may not have conducted destructive testing or chemical analysis on incoming materials and chemicals. TI and TI suppliers consider certain information to be proprietary, and thus CAS numbers and other limited information may not be available for release.

In no event shall TI's liability arising out of such information exceed the total purchase price of the TI part(s) at issue in this document sold by TI to Customer on an annual basis.

**TAPE AND REEL INFORMATION**

**QUADRANT ASSIGNMENTS FOR PIN 1 ORIENTATION IN TAPE**


\*All dimensions are nominal

Device	Package Type	Package Drawing	Pins	SPQ	Reel Diameter (mm)	Reel Width W1 (mm)	A0 (mm)	B0 (mm)	K0 (mm)	P1 (mm)	W (mm)	Pin1 Quadrant
TPD8E003DQDR	WSON	DQD	8	3000	180.0	8.4	1.65	2.0	0.95	4.0	8.0	Q1

TAPE AND REEL BOX DIMENSIONS

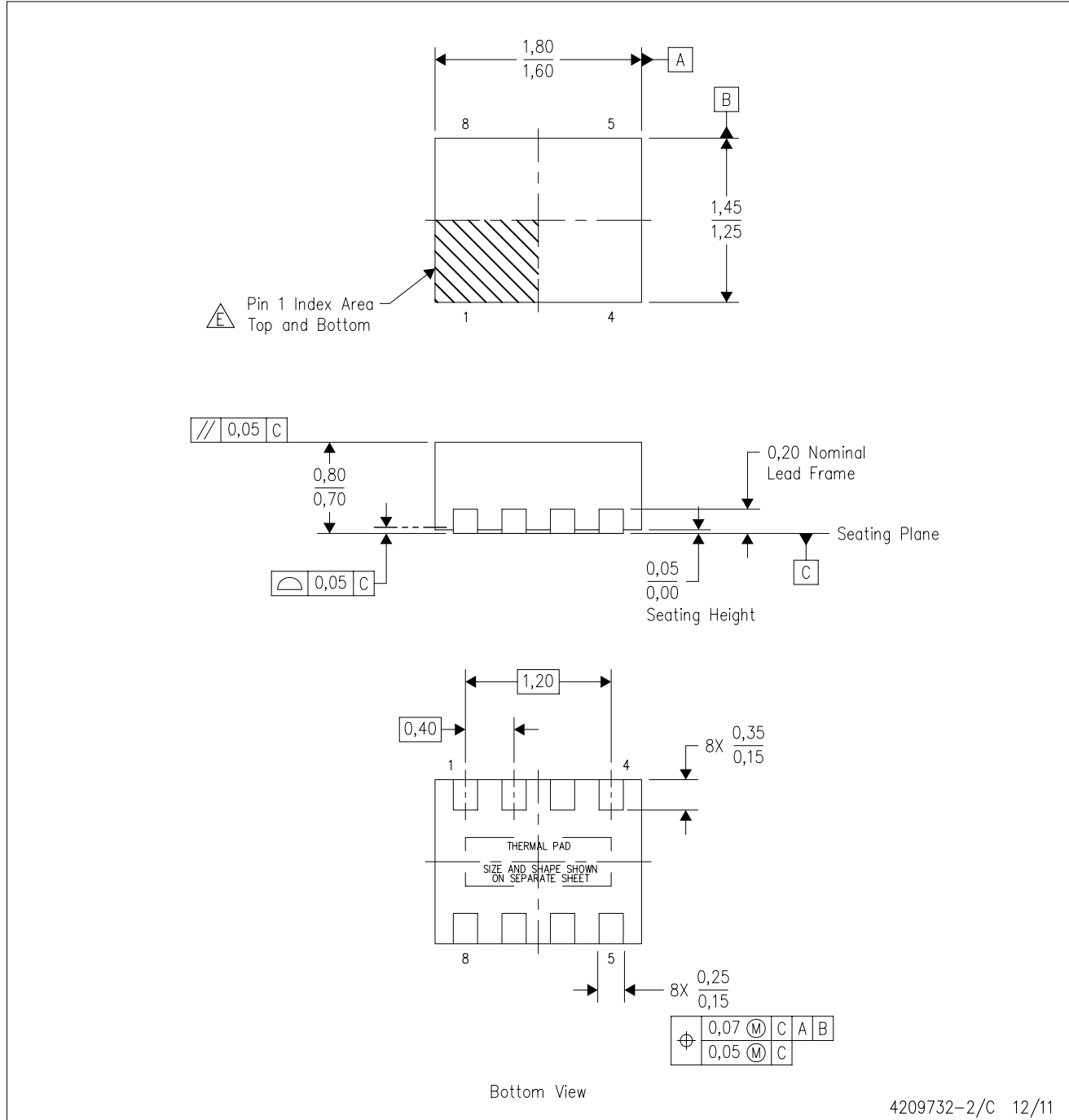


\*All dimensions are nominal

Device	Package Type	Package Drawing	Pins	SPQ	Length (mm)	Width (mm)	Height (mm)
TPD8E003DQDR	WSON	DQD	8	3000	183.0	183.0	20.0

DQD (R-PWSON-N8)

PLASTIC SMALL OUTLINE NO-LEAD



4209732-2/C 12/11

- NOTES:
- A. All linear dimensions are in millimeters. Dimensioning and tolerancing per ASME Y14.5M-1994.
  - B. This drawing is subject to change without notice.
  - C. SON (Small Outline No-Lead) package configuration.
  - D. The package thermal pad must be soldered to the board for thermal and mechanical performance.
  - E. See the additional figure in the Product Data Sheet for details regarding the exposed thermal pad features and dimensions.
- △ Pin 1 identifiers are located on both top and bottom of the package and within the zone indicated. The Pin 1 identifiers are either a molded, marked, or metal feature.

# THERMAL PAD MECHANICAL DATA

DQD (R-PWSON-N8)

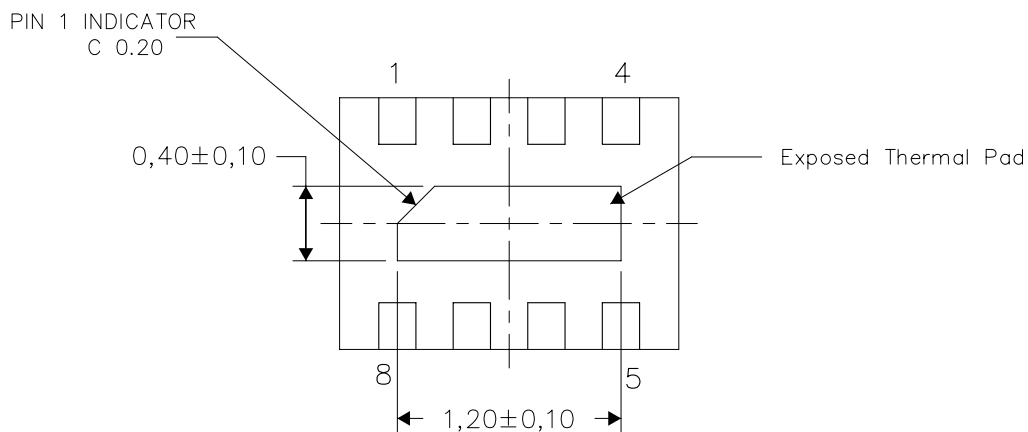
PLASTIC SMALL OUTLINE NO-LEAD

## THERMAL INFORMATION

This package incorporates an exposed thermal pad that is designed to be attached directly to an external heatsink. The thermal pad must be soldered directly to the printed circuit board (PCB). After soldering, the PCB can be used as a heatsink. In addition, through the use of thermal vias, the thermal pad can be attached directly to the appropriate copper plane shown in the electrical schematic for the device, or alternatively, can be attached to a special heatsink structure designed into the PCB. This design optimizes the heat transfer from the integrated circuit (IC).

For information on the Quad Flatpack No-Lead (QFN) package and its advantages, refer to Application Report, QFN/SON PCB Attachment, Texas Instruments Literature No. SLUA271. This document is available at [www.ti.com](http://www.ti.com).

The exposed thermal pad dimensions for this package are shown in the following illustration.

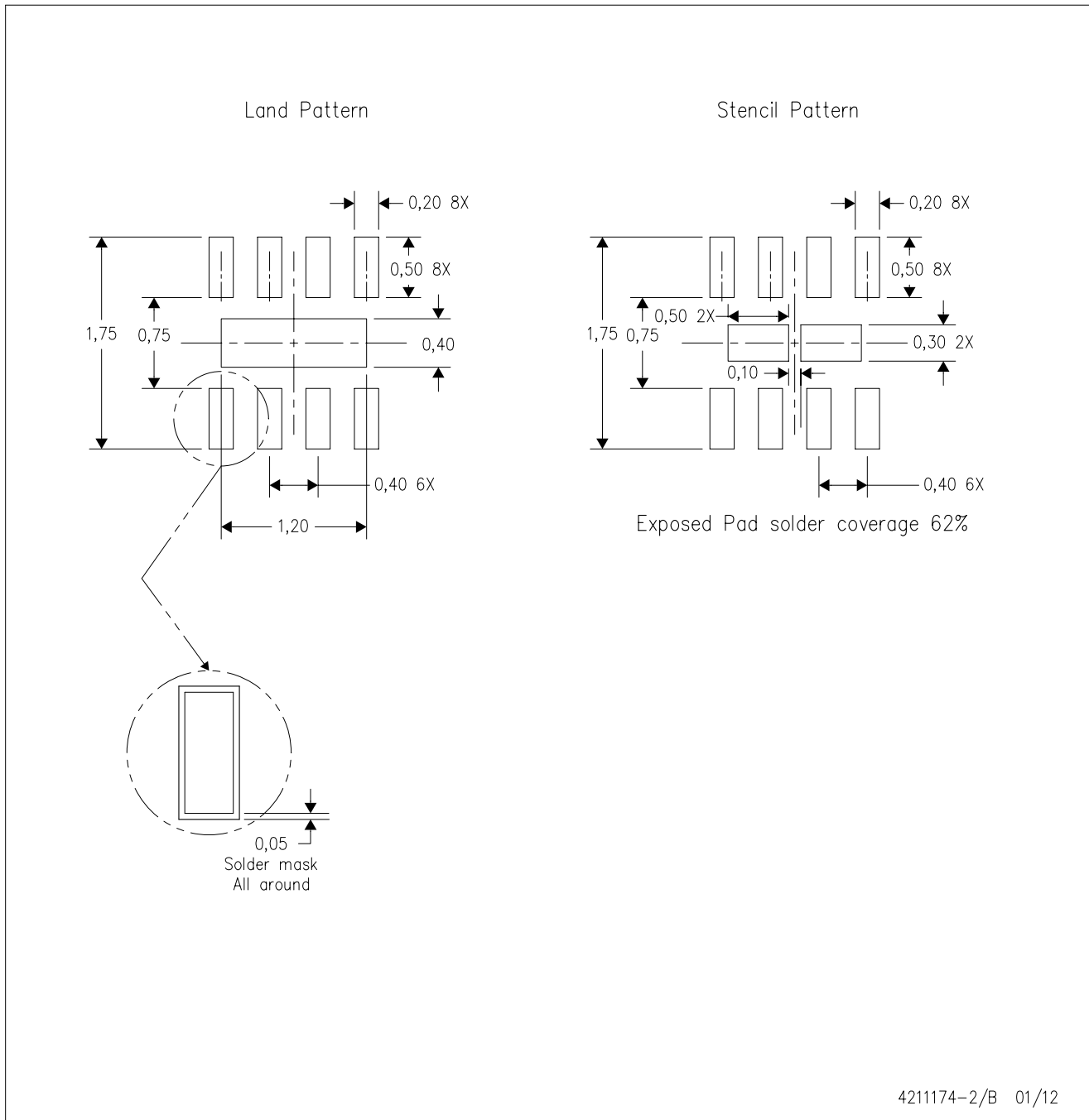


Bottom View

Exposed Thermal Pad Dimensions

4209733-2/C 12/11

NOTE: All linear dimensions are in millimeters



- NOTES:
- All linear dimensions are in millimeters.
  - This drawing is subject to change without notice.
  - Publication IPC-7351 is recommended for alternate designs.
  - Customers should contact their board fabrication site for minimum solder mask web tolerances between signal pads.
  - Maximum stencil thickness 0,1016 mm (4 mils). All linear dimensions are in millimeters.
  - Laser cutting apertures with trapezoidal walls and also rounding corners will offer better paste release. Customers should contact their board assembly site for stencil design recommendations. Refer to IPC 7525 for stencil design considerations.
  - Side aperture dimensions over-print land for acceptable area ratio > 0.66. Customer may reduce side aperture dimensions if stencil manufacturing process allows for sufficient release at smaller opening.

## IMPORTANT NOTICE

Texas Instruments Incorporated (TI) reserves the right to make corrections, enhancements, improvements and other changes to its semiconductor products and services per JESD46, latest issue, and to discontinue any product or service per JESD48, latest issue. Buyers should obtain the latest relevant information before placing orders and should verify that such information is current and complete.

TI's published terms of sale for semiconductor products (<http://www.ti.com/sc/docs/stdterms.htm>) apply to the sale of packaged integrated circuit products that TI has qualified and released to market. Additional terms may apply to the use or sale of other types of TI products and services.

Reproduction of significant portions of TI information in TI data sheets is permissible only if reproduction is without alteration and is accompanied by all associated warranties, conditions, limitations, and notices. TI is not responsible or liable for such reproduced documentation. Information of third parties may be subject to additional restrictions. Resale of TI products or services with statements different from or beyond the parameters stated by TI for that product or service voids all express and any implied warranties for the associated TI product or service and is an unfair and deceptive business practice. TI is not responsible or liable for any such statements.

Buyers and others who are developing systems that incorporate TI products (collectively, "Designers") understand and agree that Designers remain responsible for using their independent analysis, evaluation and judgment in designing their applications and that Designers have full and exclusive responsibility to assure the safety of Designers' applications and compliance of their applications (and of all TI products used in or for Designers' applications) with all applicable regulations, laws and other applicable requirements. Designer represents that, with respect to their applications, Designer has all the necessary expertise to create and implement safeguards that (1) anticipate dangerous consequences of failures, (2) monitor failures and their consequences, and (3) lessen the likelihood of failures that might cause harm and take appropriate actions. Designer agrees that prior to using or distributing any applications that include TI products, Designer will thoroughly test such applications and the functionality of such TI products as used in such applications.

TI's provision of technical, application or other design advice, quality characterization, reliability data or other services or information, including, but not limited to, reference designs and materials relating to evaluation modules, (collectively, "TI Resources") are intended to assist designers who are developing applications that incorporate TI products; by downloading, accessing or using TI Resources in any way, Designer (individually or, if Designer is acting on behalf of a company, Designer's company) agrees to use any particular TI Resource solely for this purpose and subject to the terms of this Notice.

TI's provision of TI Resources does not expand or otherwise alter TI's applicable published warranties or warranty disclaimers for TI products, and no additional obligations or liabilities arise from TI providing such TI Resources. TI reserves the right to make corrections, enhancements, improvements and other changes to its TI Resources. TI has not conducted any testing other than that specifically described in the published documentation for a particular TI Resource.

Designer is authorized to use, copy and modify any individual TI Resource only in connection with the development of applications that include the TI product(s) identified in such TI Resource. NO OTHER LICENSE, EXPRESS OR IMPLIED, BY ESTOPPEL OR OTHERWISE TO ANY OTHER TI INTELLECTUAL PROPERTY RIGHT, AND NO LICENSE TO ANY TECHNOLOGY OR INTELLECTUAL PROPERTY RIGHT OF TI OR ANY THIRD PARTY IS GRANTED HEREIN, including but not limited to any patent right, copyright, mask work right, or other intellectual property right relating to any combination, machine, or process in which TI products or services are used. Information regarding or referencing third-party products or services does not constitute a license to use such products or services, or a warranty or endorsement thereof. Use of TI Resources may require a license from a third party under the patents or other intellectual property of the third party, or a license from TI under the patents or other intellectual property of TI.

TI RESOURCES ARE PROVIDED "AS IS" AND WITH ALL FAULTS. TI DISCLAIMS ALL OTHER WARRANTIES OR REPRESENTATIONS, EXPRESS OR IMPLIED, REGARDING RESOURCES OR USE THEREOF, INCLUDING BUT NOT LIMITED TO ACCURACY OR COMPLETENESS, TITLE, ANY EPIDEMIC FAILURE WARRANTY AND ANY IMPLIED WARRANTIES OF MERCHANTABILITY, FITNESS FOR A PARTICULAR PURPOSE, AND NON-INFRINGEMENT OF ANY THIRD PARTY INTELLECTUAL PROPERTY RIGHTS. TI SHALL NOT BE LIABLE FOR AND SHALL NOT DEFEND OR INDEMNIFY DESIGNER AGAINST ANY CLAIM, INCLUDING BUT NOT LIMITED TO ANY INFRINGEMENT CLAIM THAT RELATES TO OR IS BASED ON ANY COMBINATION OF PRODUCTS EVEN IF DESCRIBED IN TI RESOURCES OR OTHERWISE. IN NO EVENT SHALL TI BE LIABLE FOR ANY ACTUAL, DIRECT, SPECIAL, COLLATERAL, INDIRECT, PUNITIVE, INCIDENTAL, CONSEQUENTIAL OR EXEMPLARY DAMAGES IN CONNECTION WITH OR ARISING OUT OF TI RESOURCES OR USE THEREOF, AND REGARDLESS OF WHETHER TI HAS BEEN ADVISED OF THE POSSIBILITY OF SUCH DAMAGES.

Unless TI has explicitly designated an individual product as meeting the requirements of a particular industry standard (e.g., ISO/TS 16949 and ISO 26262), TI is not responsible for any failure to meet such industry standard requirements.

Where TI specifically promotes products as facilitating functional safety or as compliant with industry functional safety standards, such products are intended to help enable customers to design and create their own applications that meet applicable functional safety standards and requirements. Using products in an application does not by itself establish any safety features in the application. Designers must ensure compliance with safety-related requirements and standards applicable to their applications. Designer may not use any TI products in life-critical medical equipment unless authorized officers of the parties have executed a special contract specifically governing such use. Life-critical medical equipment is medical equipment where failure of such equipment would cause serious bodily injury or death (e.g., life support, pacemakers, defibrillators, heart pumps, neurostimulators, and implantables). Such equipment includes, without limitation, all medical devices identified by the U.S. Food and Drug Administration as Class III devices and equivalent classifications outside the U.S.

TI may expressly designate certain products as completing a particular qualification (e.g., Q100, Military Grade, or Enhanced Product). Designers agree that it has the necessary expertise to select the product with the appropriate qualification designation for their applications and that proper product selection is at Designers' own risk. Designers are solely responsible for compliance with all legal and regulatory requirements in connection with such selection.

Designer will fully indemnify TI and its representatives against any damages, costs, losses, and/or liabilities arising out of Designer's non-compliance with the terms and provisions of this Notice.

## Looking for pricing, stock, or lifecycle information?

Click below to explore more details on WIN SOURCE:

 [View TPD8E003DQDR](#) on WIN SOURCE

 [Texas Instruments](#) Information

## Optimize Your Supply Chain with WIN SOURCE Solutions

-  Global Sourcing Solution
-  Obsolete Management
-  Cost Control Management
-  Shortage Management
-  Alternative Solution
-  Excess Inventory Management