

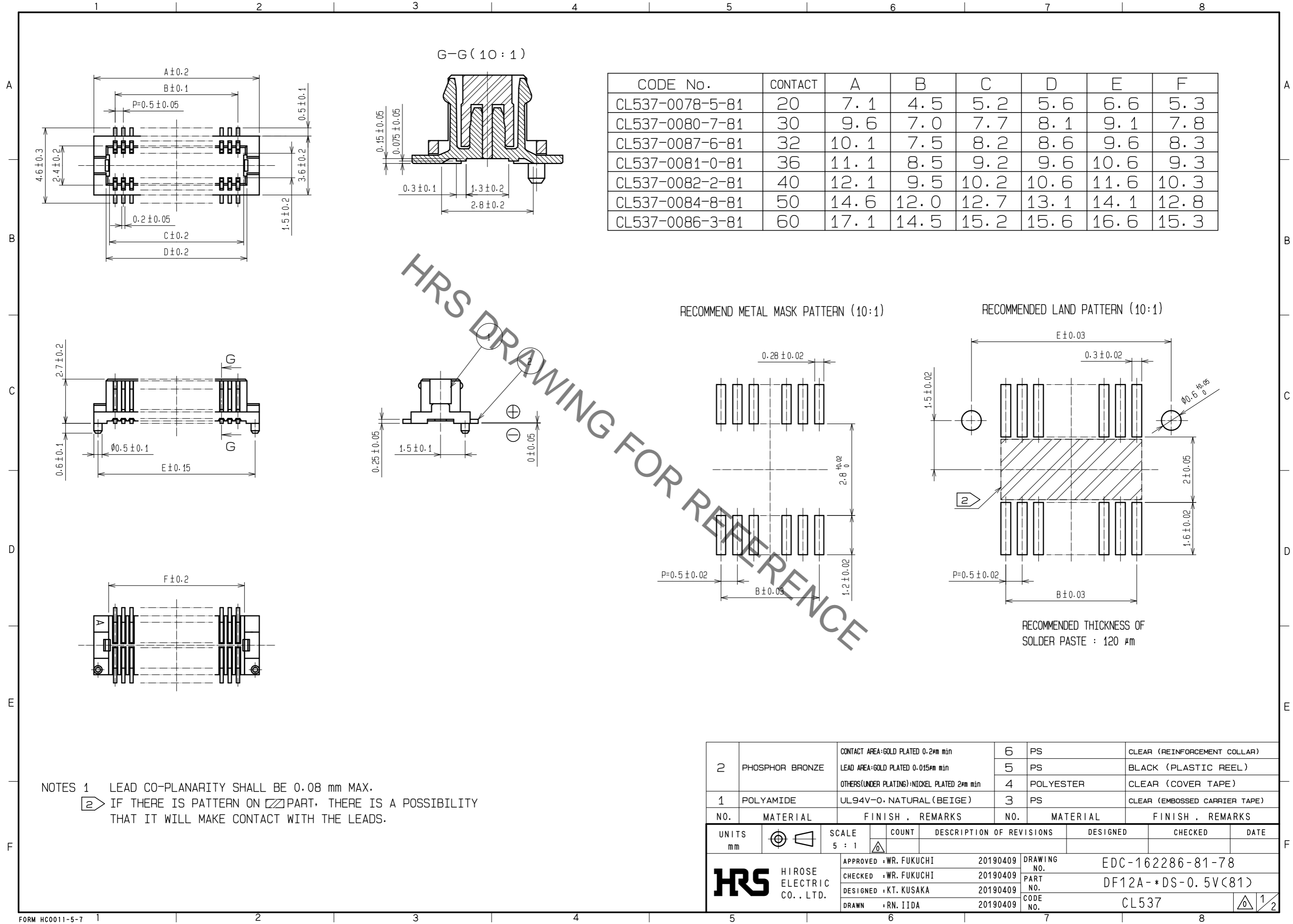

**THE DATASHEET OF
DF12A-30DS-0.5V(81)**



Sep.1.2019 Copyright 2019 HIROSE ELECTRIC CO., LTD. All Rights Reserved.
In case of consideration for using Automotive equipment / device which demand high reliability, kindly contact our sales window correspondents.



CODE No.	CONTACT	A	B	C	D	E	F
CL537-0078-5-81	20	7.1	4.5	5.2	5.6	6.6	5.3
CL537-0080-7-81	30	9.6	7.0	7.7	8.1	9.1	7.8
CL537-0087-6-81	32	10.1	7.5	8.2	8.6	9.6	8.3
CL537-0081-0-81	36	11.1	8.5	9.2	9.6	10.6	9.3
CL537-0082-2-81	40	12.1	9.5	10.2	10.6	11.6	10.3
CL537-0084-8-81	50	14.6	12.0	12.7	13.1	14.1	12.8
CL537-0086-3-81	60	17.1	14.5	15.2	15.6	16.6	15.3

HRS DRAWING FOR REFERENCE

NOTES 1 LEAD CO-PLANARITY SHALL BE 0.08 mm MAX.
 2 IF THERE IS PATTERN ON PART, THERE IS A POSSIBILITY THAT IT WILL MAKE CONTACT WITH THE LEADS.

NO.	MATERIAL	FINISH	REMARKS	NO.	MATERIAL	FINISH	REMARKS
2	PHOSPHOR BRONZE	CONTACT AREA:GOLD PLATED 0.2μm min		6	PS		CLEAR (REINFORCEMENT COLLAR)
		LEAD AREA:GOLD PLATED 0.015μm min		5	PS		BLACK (PLASTIC REEL)
		OTHERS(UNDER PLATING):NICKEL PLATED 2μm min		4	POLYESTER		CLEAR (COVER TAPE)
1	POLYAMIDE	UL94V-0	NATURAL (BEIGE)	3	PS		CLEAR (EMBOSSED CARRIER TAPE)

UNITS	SCALE	COUNT	DESCRIPTION OF REVISIONS	DESIGNED	CHECKED	DATE
mm	5 : 1	△				

HRS HIROSE ELECTRIC CO., LTD.	APPROVED : WR. FUKUCHI	20190409	DRAWING NO.	EDC-162286-81-78
	CHECKED : WR. FUKUCHI	20190409	PART NO.	DF12A-*DS-0.5V(81)
	DESIGNED : KT. KUSAKA	20190409	CODE NO.	CL537
	DRAWN : RN. IIDA	20190409		

Sep.1.2019 Copyright 2019 HIROSE ELECTRIC CO., LTD. All Rights Reserved.
 In case of consideration for using Automotive equipment / device which demand high reliability, kindly contact our sales window correspondents.

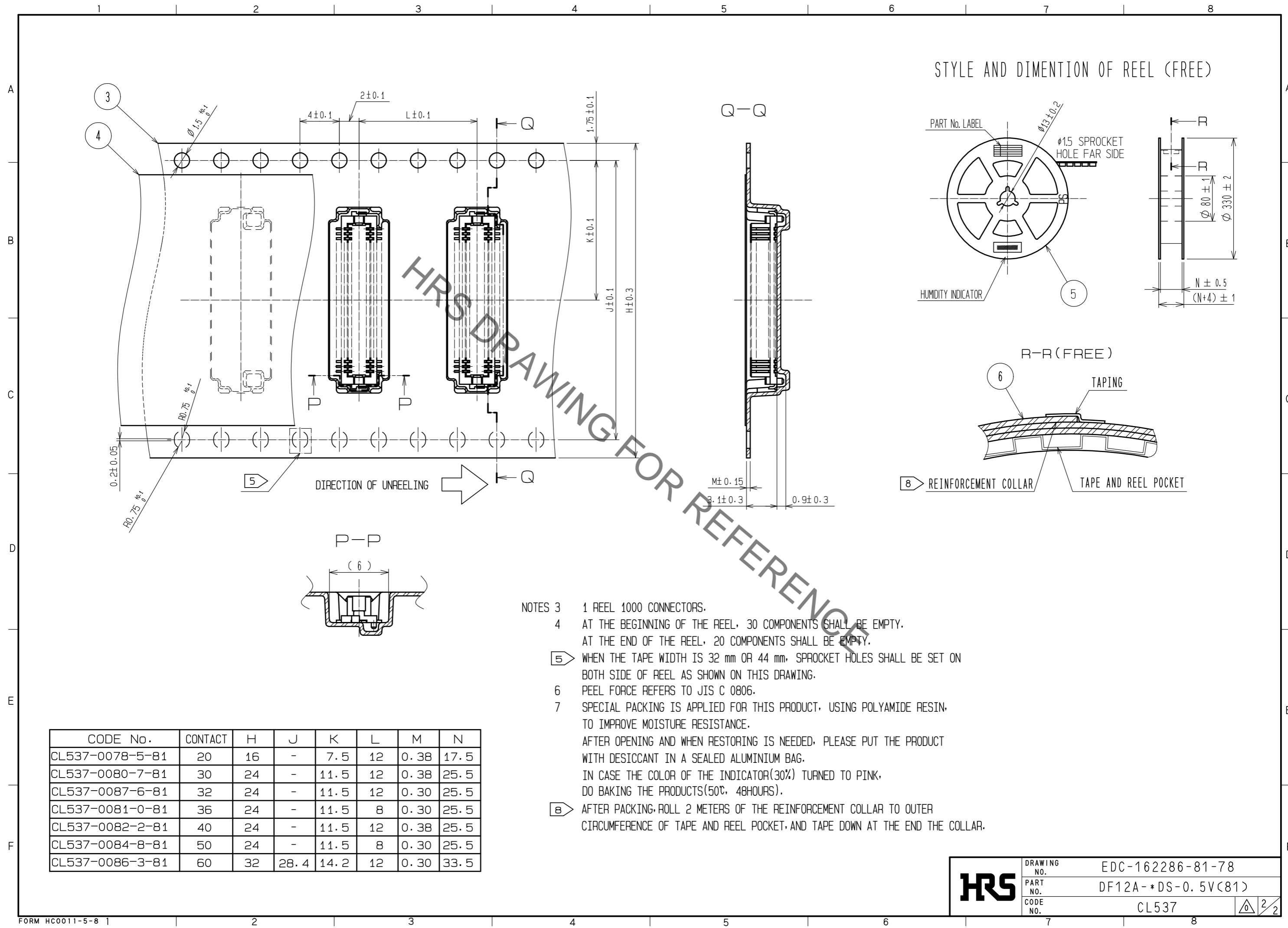

STYLE AND DIMENTION OF REEL (FREE)

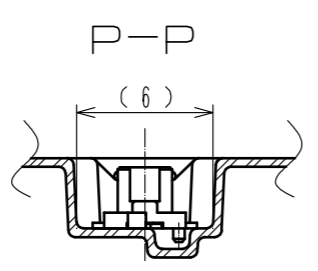
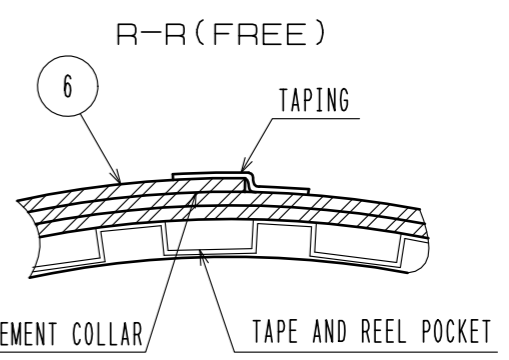
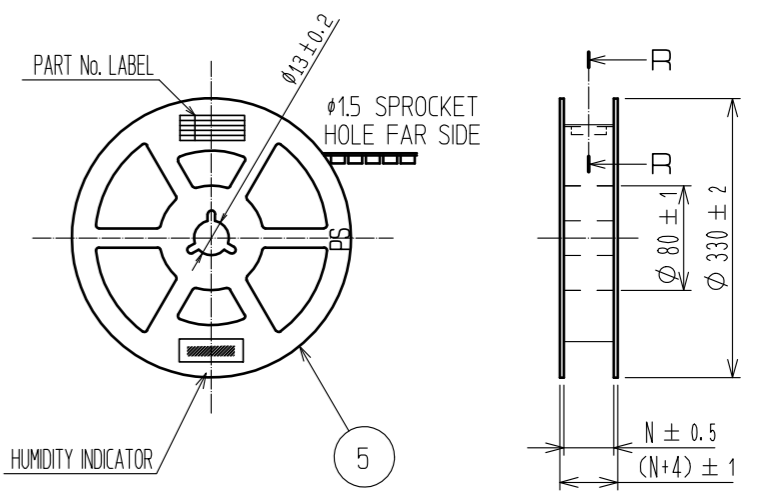

- NOTES 3 1 REEL 1000 CONNECTORS.
 4 AT THE BEGINNING OF THE REEL, 30 COMPONENTS SHALL BE EMPTY.
 AT THE END OF THE REEL, 20 COMPONENTS SHALL BE EMPTY.
 5 WHEN THE TAPE WIDTH IS 32 mm OR 44 mm, SPROCKET HOLES SHALL BE SET ON BOTH SIDE OF REEL AS SHOWN ON THIS DRAWING.
 6 PEEL FORCE REFERS TO JIS C 0806.
 7 SPECIAL PACKING IS APPLIED FOR THIS PRODUCT, USING POLYAMIDE RESIN, TO IMPROVE MOISTURE RESISTANCE.
 AFTER OPENING AND WHEN RESTORING IS NEEDED, PLEASE PUT THE PRODUCT WITH DESICCANT IN A SEALED ALUMINIUM BAG.
 IN CASE THE COLOR OF THE INDICATOR(30%) TURNED TO PINK, DO BAKING THE PRODUCTS(50℃, 48HOURS).
 8 AFTER PACKING, ROLL 2 METERS OF THE REINFORCEMENT COLLAR TO OUTER CIRCUMFERENCE OF TAPE AND REEL POCKET, AND TAPE DOWN AT THE END THE COLLAR.

CODE No.	CONTACT	H	J	K	L	M	N
CL537-0078-5-81	20	16	-	7.5	12	0.38	17.5
CL537-0080-7-81	30	24	-	11.5	12	0.38	25.5
CL537-0087-6-81	32	24	-	11.5	12	0.30	25.5
CL537-0081-0-81	36	24	-	11.5	8	0.30	25.5
CL537-0082-2-81	40	24	-	11.5	12	0.38	25.5
CL537-0084-8-81	50	24	-	11.5	8	0.30	25.5
CL537-0086-3-81	60	32	28.4	14.2	12	0.30	33.5

HRS DRAWING NO. EDC-162286-81-78
 PART NO. DF12A-*DS-0.5V(81)
 CODE NO. CL537

2/2

Looking for pricing, stock, or lifecycle information?

Click below to explore more details on WIN SOURCE:

- [View DF12A-30DS-0.5V\(81\) on WIN SOURCE](#)
- [Hirose Electric Co Ltd Information](#)

Optimize Your Supply Chain with WIN SOURCE Solutions

- ✓ Global Sourcing Solution
- ✓ Obsolete Management
- ✓ Cost Control Management
- ✓ Shortage Management
- ✓ Alternative Solution
- ✓ Excess Inventory Management