



**THE DATASHEET OF
ACT30BHT-1119**



High Performance Off-Line Controller ActiveSwitcher™ IC Family

FEATURES

- Lowest Total Cost Solution
- 0.15W Standby Power
- Emitter Drive Allows Safe NPN Transistor Flyback Use
- Hiccup Mode Short Circuit
- Current Mode Operation
- Over-Current Protection
- Under-voltage Protection with Auto-Restart
- Proprietary Scalable Output Driver
- Flexible Packaging Options (Including TO-92)
- 65kHz or 100kHz Switching Frequency
- Selectable 0.4A to 1.2A Current Limit

APPLICATIONS

- Battery Chargers
- Power Adaptors
- Standby Power Supplies
- Appliances
- Universal Off-Line Power Supplies

GENERAL DESCRIPTION

The ACT30 is a high performance green-energy off-line power supply controller. It features a scalable driver for driving external NPN or MOSFET transistors for line voltage switching. This proprietary architecture enables many advanced features to be integrated into a small package (TO-92 or SOT23-B), resulting in lowest total cost solution.

The ACT30 design has six internal terminals and is a pulse frequency and width modulation IC with many flexible packaging options. One combination of internal terminals is packaged in the space-saving TO-92 package (A/B versions) for 65kHz or 100kHz switching frequency and with 400mA or 800mA current limit.

Consuming only 0.15W in standby, the IC features over-current, hiccup mode short circuit, and under-voltage protection mechanisms.

The ACT30 is ideal for use in high performance universal adaptors and chargers. For highest performance versus cost and smallest PCB area, use the ACT30 in combination with the ACT32 CV/CC Controller.

Figure 1:
Simplified Application Circuit

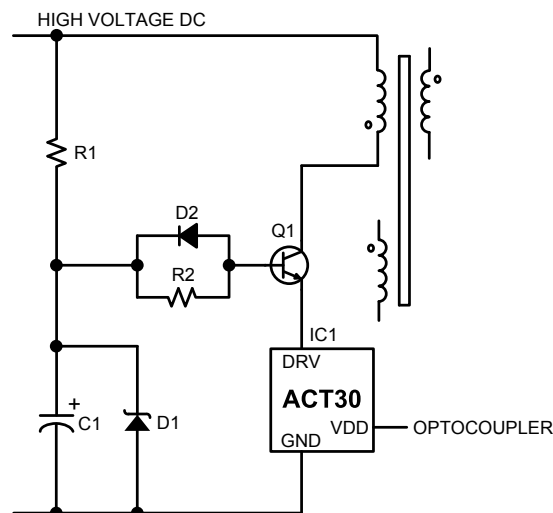

ORDERING INFORMATION

PART NUMBER	SWITCHING FREQUENCY	CURRENT LIMIT	JUNCTION TEMPERATURE	PACKAGE	PINS
ACT30AHT	65kHz	400mA	-40°C to 150°C	TO-92	3
ACT30BHT	65kHz	800mA	-40°C to 150°C	TO-92	3
ACT30AYT	65kHz	400mA	-40°C to 150°C	SOT23-B	3

PIN CONFIGURATION

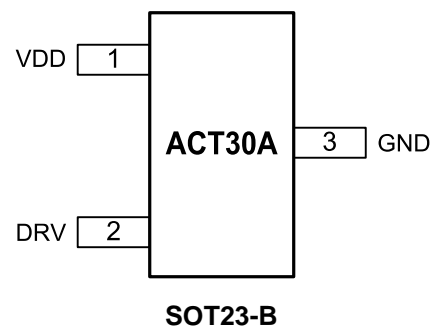
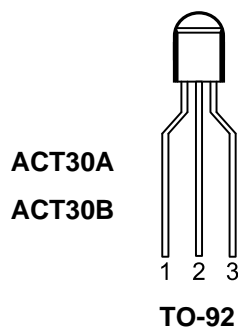

PIN DESCRIPTIONS

PIN		NAME	DESCRIPTION
TO-92	SOT23-B		
1	1	VDD	Power Supply Pin. Connect to optocoupler's emitter. Internally limited to 5.5V max. Bypass to GND with a proper compensation network.
2	3	GND	Ground.
3	2	DRV	Driver Output (TO-92 Only). Connect to emitter of the high voltage NPN or MOSFET. For ACT30A/C, DRV pin is internally connected to DRV1. For ACT30B/D, DRV pin is internally connected to both DRV1 and DRV2.

ABSOLUTE MAXIMUM RATINGS^①

PARAMETER		VALUE	UNIT
VDD, FREQ to GND		-0.3 to 6	V
VDD Current		20	mA
DRV, DRV1, DRV2 to GND		-0.3 to 18	V
Continuous DRV, DRV1, DRV2 Current		Internally limited	A
Maximum Power Dissipation	TO-92	0.6	W
	SOT23-B	0.39	
Operating Junction Temperature		-40 to 150	°C
Storage Temperature		-55 to 150	°C
Lead Temperature (Soldering, 10 sec)		300	°C

①: Do not exceed these limits to prevent damage to the device. Exposure to absolute maximum rating conditions for long periods may affect device reliability.

ELECTRICAL CHARACTERISTICS

(V_{VDD} = 4V, T_J = 25°C, unless otherwise specified.)

PARAMETER	SYMBOL	TEST CONDITIONS	MIN	TYP	MAX	UNIT	
V _{VDD} Start Voltage	V _{START}	Rising edge	4.75	5	5.25	V	
DRV1 Start Voltage	V _{DRVST}	DRV1 must be higher than this voltage to start up.	ACT30A	8.6	10.5	V	
			ACT30B	9.6	11.5		
DRV1 Short-Circuit Detect Threshold	V _{SCDRV}		6.35	6.8	7.25	V	
V _{VDD} Under-Voltage Threshold	V _{UV}	Falling edge	3.17	3.35	3.63	V	
V _{VDD} Clamp Voltage		10mA	5.15	5.45	5.95	V	
Startup Supply Current	I _{DDST}	V _{VDD} = 4V before V _{UV}		0.23	0.45	mA	
Supply Current	I _{DD}			0.7	1	mA	
Switching Frequency	f _{SW}	ACT30A/B or FREQ = 0	50	65	80	kHz	
Maximum Duty Cycle	D _{MAX}	ACT30A, V _{VDD} = 4V	67	75	83	%	
		ACT30B, V _{VDD} = 4V	60				
Minimum Duty Cycle	D _{MIN}	V _{VDD} = 4.6V		3.5		%	
Effective Current Limit	I _{LIM}	V _{VDD} = V _{UV} + 0.1V	ACT30A	340	400	480	mA
			ACT30B with DRV1 = DRV2	680	800	920	
V _{VDD} to DRV1 Current Coefficient	G _{GAIN}			-0.29		A/V	
VDD Dynamic Impedance	R _{VDD}			9		kΩ	
DRV1 or DRV2 Driver On-Resistance	R _{DRV1} , R _{DRV2}	I _{DRV1} = I _{DRV2} = 0.05A		3.6		Ω	
DRV1 Rise Time		1nF load, 15Ω pull-up		30		ns	
DRV1 Fall Time		1nF load, 15Ω pull-up		20		ns	
DRV1 and DRV2 Switch Off Current		Driver off, V _{DRV1} = V _{DRV2} = 10V		12	30	μA	

FUNCTIONAL BLOCK DIAGRAM

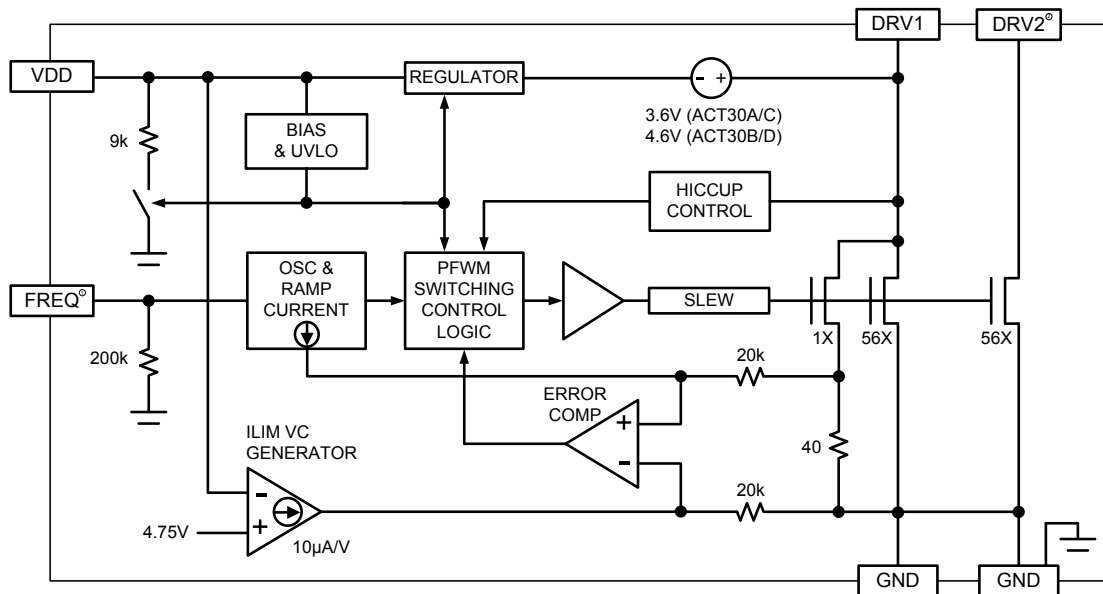

- ①: FREQ terminal wire-bonded to VDD in ACT30C/D (TO-92)
 ②: DRV2 terminal wire-bonded to DRV1 in ACT30B/D (TO-92)

FUNCTIONAL DESCRIPTION

As seen in the *Functional Block Diagram*, the main components include switching control logic, two on-chip medium-voltage power-MOSFETs with parallel current sensor, driver, oscillator and ramp generator, current limit VC generator, error comparator, hiccup control, bias and under voltage-lockout, and regulator circuitry.

As seen in the *Functional Block Diagram*, the design has six internal terminals. V_{DD} is the power supply terminal. DRV1 and DRV2 are linear driver outputs that can drive the emitter of an external high voltage NPN transistor or N-channel MOSFET. This emitter-drive method takes advantage of the high V_{CBO} of the transistor, allowing a low cost transistor such as '13003 ($V_{CBO} = 700V$) or '13002 ($V_{CBO} = 600V$) to be used for a wide AC input range. The slew-rate limited driver coupled with the turn-off characteristics of an external NPN transistor result in lower EMI.

The driver peak current is designed to have a negative voltage coefficient with respect to supply voltage V_{DD} , so that lower supply voltage automatically results in higher DRV1 peak current. This way, the optocoupler can control V_{DD} directly to affect driver current.

Startup Sequence

Figure 1 shows a *Simplified Application Circuit* for the ACT30. Initially, the small current through resistor R1 charges up the capacitor C1, and the BJT acts as a follower to bring up the DRV1 voltage. An internal regulator generates a V_{DD} voltage equal to $V_{DRV1} - 3.6V$ for ACT30A ($V_{DRV1} - 4.6V$ for ACT30B) but limits it to 5.5V max. As V_{DD} crosses 5V, the regulator sourcing function stops and V_{DD} begins to drop due to its current consumption. As V_{DD} voltage decreases below 4.75V, the IC starts to operate with increasing driver current. When the output voltage reaches regulation point, the optocoupler feedback circuit stops V_{DD} from decreasing further. The switching action also allows the auxiliary windings to take over in supplying the C1 capacitor. Figure 2 shows a typical startup sequence for the ACT30.

To limit the auxiliary voltage, use a 12V zener diode for ACT30A or a 13V zener diode for ACT30B (D1 diode in Figure 1).

Even though up to 2MΩ startup resistor (R1) can be used due to the very low startup current, the actual R1 value should be chosen as a compromise between standby power and startup time delay.

Figure 2:
Startup Waveforms

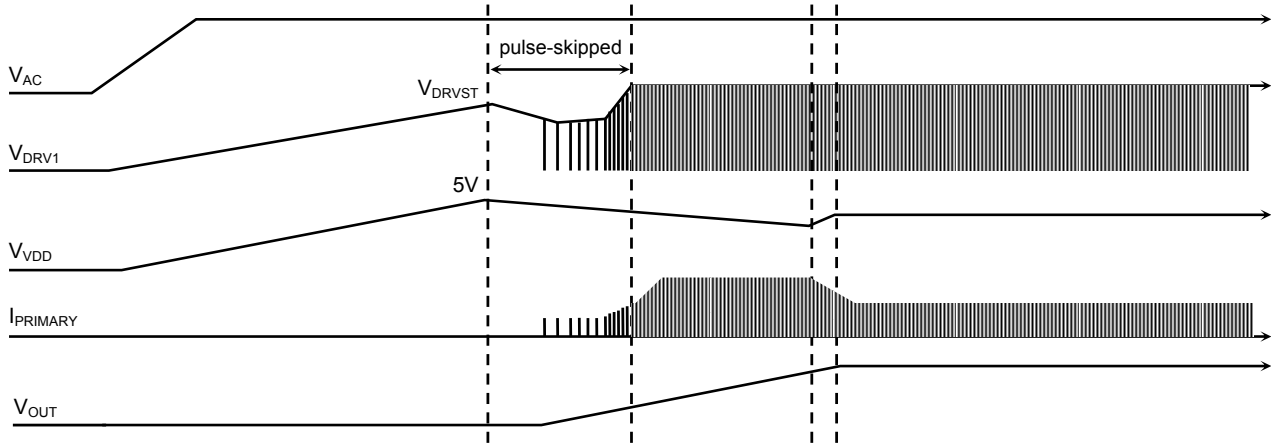

Normal Operation

In normal operation, the feedback signal from the secondary side is transmitted through the optocoupler as a current signal into V_{VDD} pin, which has dynamic impedance of $9k\Omega$. The resulting V_{VDD} voltage affects the switching of the IC. As seen in the *Functional Block Diagram*, the Current Limit VC Generator uses the V_{VDD} voltage difference with $4.75V$ to generate a proportional offset at the negative input of the Error Comparator.

The drivers turn on at the beginning of each switching cycle. The current sense resistor current, which is a fraction of the transformer primary current, increases with time as the primary current increases. When the voltage across this current sense resistor plus the oscillator ramp signal equals Error Comparator's negative input voltage, the drivers turn off. Thus, the peak DRV1 current has a negative voltage coefficient of $-0.29A/V$ and can be calculated from the following:

$$I_{DRV1PEAK} = 0.29A/V \times (4.75V - V_{VDD})$$

for $V_{VDD} < 4.75V$ and duty cycle $< 50\%$.

When the output voltage is lower than regulation, the current into V_{VDD} pin is zero and V_{VDD} voltage decreases. At $V_{VDD} = V_{UV} = 3.35V$, the peak DRV1 current has maximum value of $400mA$.

Current Limit Adjustment

The IC's proprietary driver arrangement allows the current limit to be easily adjusted between $400mA$ and $1.2A$. To understand this, the drivers have to be utilized as linear resistive devices with typically

3.6Ω (rather than as digital output switches). The current limit can then be calculated through linear combination as shown in Figure 3. For TO-92 package, the ACT30A are preprogrammed to $400mA$ current limit and the ACT30B are preprogrammed to $800mA$ current limit, for SOT23-B package, the ACT30A are preprogrammed to $400mA$ current limit.

Figure 3:
Driver Output Configurations

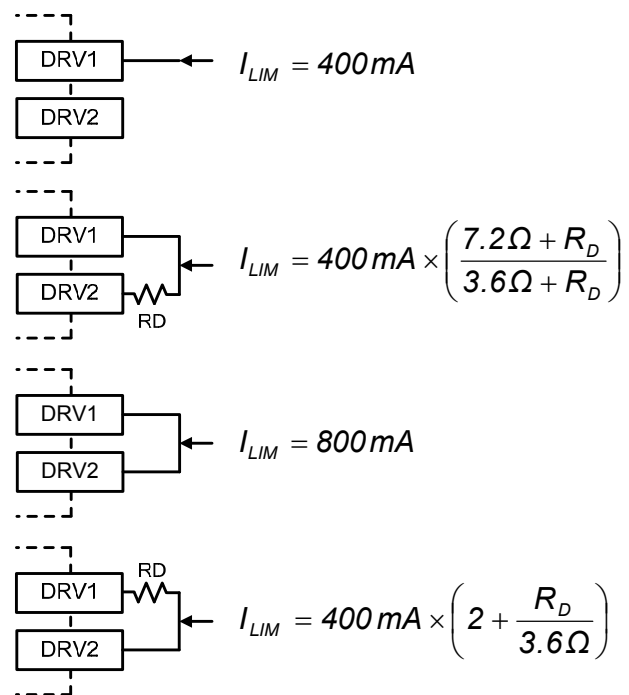

Pulse Modulation

The PFWM Switching Control Logic block operates in different modes depending on the output load current level. At light load, the V_{VDD} voltage is around 4.75V. The energy delivered by each switching cycle (with minimum on time of 500ns) to the output causes V_{VDD} to increase slightly above 4.75V. The FPWM Switching Control Logic block is able to detect this condition and prevents the IC from switching until V_{VDD} is below 4.75V again. This results in a pulse-modulation action with fixed pulse width and varying frequency, and low power consumption because the switching frequency is reduced. Typical system standby power consumption is 0.15W.

Short Circuit Hiccup

When the output is short circuited, the ACT30 enters hiccup mode operation. In this condition, the auxiliary supply voltage collapses. An on-chip detector compares DRV1 voltage during the off-time of each cycle to 6.8V. If DRV1 voltage is below 6.8V, the IC will not start the next cycle, causing both the auxiliary supply voltage and V_{VDD} to reduce further. The circuit enters startup mode when V_{VDD} drops below 3.35V. This hiccup behavior continues until the short circuit is removed. In this behavior, the effective duty cycle is very low resulting in very low short circuit current.

To make sure that the IC enters hiccup mode easily, the transformer should be constructed so that there is close coupling between secondary and auxiliary, so that the auxiliary voltage is low when the output is short-circuited. This can be achieved with the primary/auxiliary/secondary sequencing from the bobbin.

Application Example

The application circuit in Figure 5 provides a 5V/0.75A constant voltage/constant current output. The performance of this circuit is summarized in Table 2.

Table 2:

System Performance of Circuit in Figure 5

	110VAC	220VAC
Standby Power	0.09W	0.15W
Current Limit	0.75A	0.75A
Full Load Efficiency	65%	67%

Layout Considerations

The following should be observed when doing layout for the ACT30:

- 1) Use a "star point" connection at the GND pin of ACT30 for the VDD bypass components (C5 and C6 in Figure 5), the input filter capacitor (C2 in Figure 5) and other ground connections on the primary side.
- 2) Keep the loop across the input filter capacitor, the transformer primary windings, and the high voltage transistor, and the ACT30 as small as possible.
- 3) Keep ACT30 pins and the high voltage transistor pins as short as possible.
- 4) Keep the loop across the secondary windings, the output diode, and the output capacitors as small as possible.
- 5) Allow enough copper area under the high voltage transistor, output diode, and current shunt resistor for heat sink.

PACKAGE OUTLINE

TO-92 PACKAGE OUTLINE AND DIMENSIONS (AMMO TAPE PACKING)

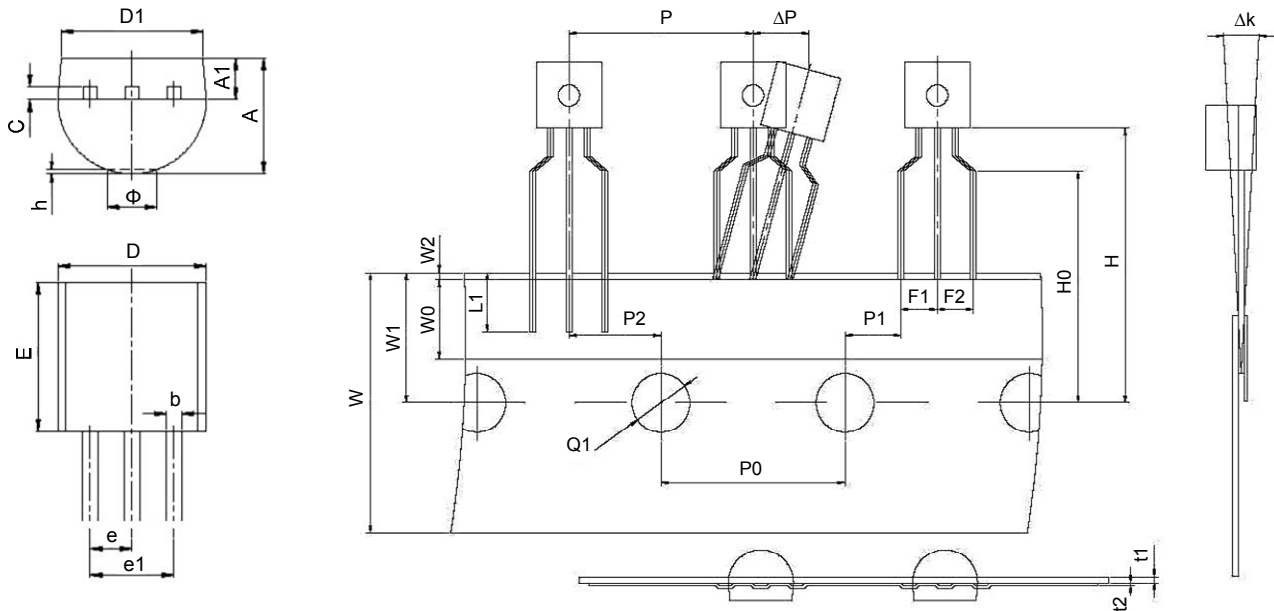

SYMBOL	DIMENSION IN MILLIMETERS		DIMENSION IN INCHES	
	MIN	MAX	MIN	MAX
A	3.300	3.700	0.130	0.146
A1	1.100	1.400	0.043	0.055
b	0.380	0.550	0.015	0.022
c	0.360	0.510	0.014	0.020
D	4.400	4.700	0.173	0.185
D1	3.430		0.135	
E	4.300	4.700	0.169	0.185
e	1.270 TYP		0.050 TYP	
e1	2.440	2.640	0.096	0.104
Φ		1.600		0.063
h	0.000	0.380	0.000	0.015

SYMBOL	DIMENSION IN MILLIMETERS		DIMENSION IN INCHES	
	MIN	MAX	MIN	MAX
Δk	-1.000	1.000	-0.039	0.039
F1, F2	2.200	2.800	0.087	0.110
H	19.00	21.00	0.748	0.827
H0	15.50	16.50	0.610	0.650
L1	2.500		0.098	
P	12.40	13.00	0.488	0.512
ΔP	-1.000	1.000	-0.039	0.039
P0	12.50	12.90	0.492	0.508
P1	3.550	4.150	0.140	0.163
P2	6.050	6.650	0.238	0.262
Q1	3.800	4.200	0.150	0.165
t1	0.350	0.450	0.014	0.018
t2	0.150	0.250	0.006	0.010
W	17.50	19.00	0.689	0.748
W0	5.500	6.500	0.217	0.256
W1	8.500	9.500	0.335	0.374
W2		1.000		0.039

SOT23-B PACKAGE OUTLINE AND DIMENSIONS

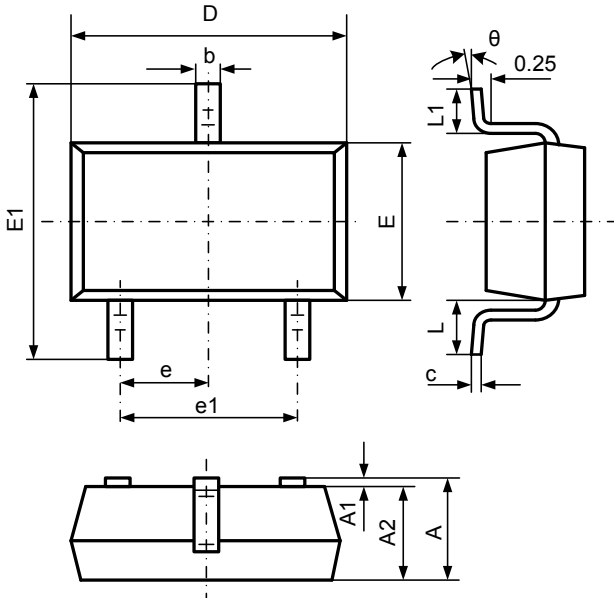

SYMBOL	DIMENSION IN MILLIMETERS		DIMENSION IN INCHES	
	MIN	MAX	MIN	MAX
A	1.900	1.150	0.035	0.045
A1	0.000	0.100	0.000	0.004
A2	0.900	1.050	0.035	0.041
b	0.300	0.500	0.012	0.020
c	0.080	0.150	0.003	0.006
D	2.800	3.000	0.110	0.118
E	1.200	1.400	0.047	0.055
E1	2.250	2.550	0.089	0.100
e	0.950 TYP		0.037 TYP	
e1	1.800	2.000	0.071	0.079
L	0.550 REF		0.022 REF	
L1	0.300	0.500	0.012	0.020
θ	0°	8°	0°	8°

Active-Semi, Inc. reserves the right to modify the circuitry or specifications without notice. Users should evaluate each product to make sure that it is suitable for their applications. Active-Semi products are not intended or authorized for use as critical components in life-support devices or systems. Active-Semi, Inc. does not assume any liability arising out of the use of any product or circuit described in this datasheet, nor does it convey any patent license.

Active-Semi and its logo are trademarks of Active-Semi, Inc. For more information on this and other products, contact sales@active-semi.com or visit <http://www.active-semi.com>. For other inquiries, please send to:

2728 Orchard Parkway, San Jose, CA 95134-2012, USA

Looking for pricing, stock, or lifecycle information?

Click below to explore more details on WIN SOURCE:

- ⊖ [View ACT30BHT-1119 on WIN SOURCE](#)
- ⊖ [Active-Semi International Inc. Information](#)

Optimize Your Supply Chain with WIN SOURCE Solutions

- ✓ Global Sourcing Solution
- ✓ Obsolete Management
- ✓ Cost Control Management
- ✓ Shortage Management
- ✓ Alternative Solution
- ✓ Excess Inventory Management