



THE DATASHEET OF ACS8510



Description

The ACS8510 is a highly integrated, single-chip solution for the Synchronous Equipment Timing Source (SETS) function in a SONET or SDH Network Element. The device generates SONET or SDH Equipment Clocks (SEC) and frame synchronization clocks. The ACS8510 is fully compliant with the required specifications and standards.

The device supports Free-run, Locked and Holdover modes. It also supports all three types of reference clock source: recovered line clock, PDH network, and node synchronization. The ACS8510 generates independent SEC and BITS clocks, an 8 kHz Frame Synchronization clock and a 2 kHz Multi-Frame Synchronization clock.

Two ACS8510 devices can be used together in a Master/Slave configuration mode allowing system protection against a single ACS8510 failure.

A microprocessor port is incorporated, providing access to the configuration and status registers for device setup and monitoring. The ACS8510 supports IEEE 1149.1 JTAG boundary scan.

Rev2.1 adds choice of edge alignment for 8kHz input, as well as a low jitter n x E1/DS1 output mode. Other minor changes are made, with all described in Appendix A.

Features

- Suitable for Stratum 3E*, 3, 4E and 4 SONET or SDH Equipment Clock (SEC) applications
- Meets AT&T, ITU-T, ETSI and Telcordia specifications
- Accepts 14 individual input reference clocks
- Generates 11 output clocks
- Supports Free-run, Locked and Holdover modes of operation
- Robust input clock source quality monitoring on all inputs
- Automatic 'hit-less' source switchover on loss of input
- Phase build out for output clock phase continuity during input switchover and mode transitions
- Microprocessor interface - Intel, Motorola, Serial, Multiplexed, EPROM
- Programmable wander and jitter tracking attenuation 0.1 Hz to 20 Hz
- Support for Master/Slave device configuration alignment and hot/standby redundancy
- IEEE 1149.1 JTAG Boundary Scan
- Single +3.3 V operation, +5 V I/O compatible
- Operating temperature (ambient) -40°C to +85°C
- Available in 100 pin LQFP package

* Meets Holdover requirements, lowest bandwidth 0.1 Hz.

Block Diagram

Figure 1. Simple Block Diagram

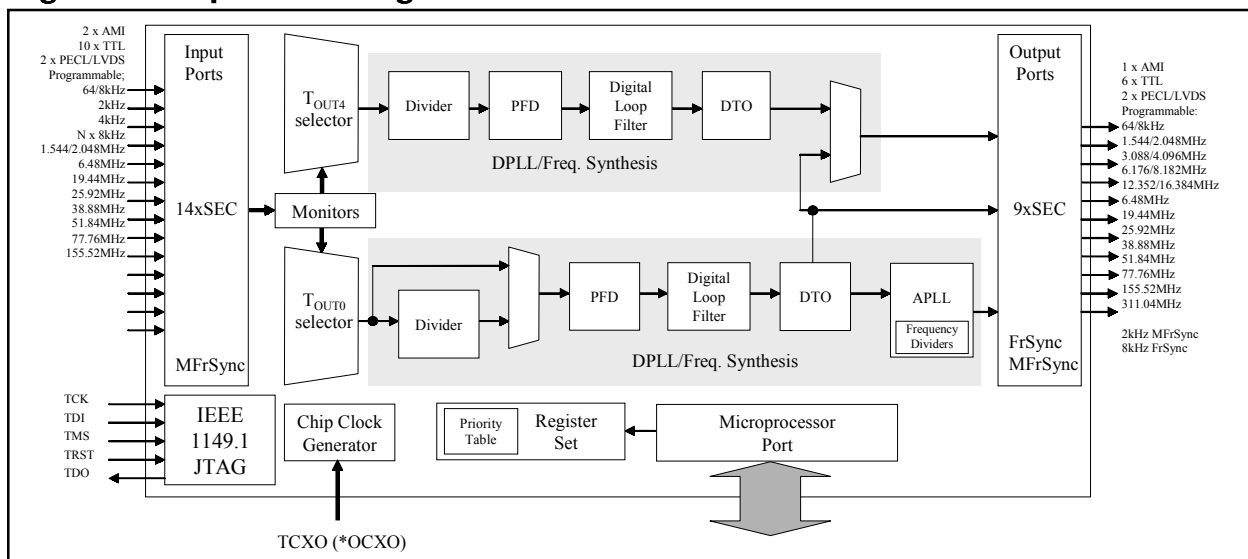

Table of Contents
List of Sections

Description	1
Block Diagram	1
Features	1
Table of Contents	2
Pin Diagram	5
Pin Descriptions	6
Functional Description	9
Local Oscillator Clock	10
ITU and ETSI Specification	10
Telcordia GR-1244 CORE Specification	10
Crystal Frequency Calibration	10
Input Interfaces	10
Over-Voltage Protection	10
Input Reference Clock Ports	11
Input Wander and Jitter Tolerance	9
Output Clock Ports	12
Low Speed Output Clock (DPLL2)	12
High Speed Output Clock (DPLL1)	12
Frame Sync and Multi-Frame Sync Clocks (Part of DPLL1)	13
Low Jitter Multiple E1/DS1 Outputs	13
Output Wander and Jitter	13
Phase Variation	18
Phase Build Out	21
Microprocessor Interface	21
Motorola Mode	21
Intel Mode	21
Multiplexed Mode	21
Serial Mode	21
EPROM Mode	21
Register Set	22
Configuration Registers	22
Status Registers	22
Register Access	22
Interrupt Enable and Clear	22
Register Map	23
Register Map Description	27
Selection of Input Reference Clock Source	36
Forced Control Selection	37
Automatic Control Selection	37
Ultra Fast Switching	37
External Protection Switching	38
Clock Quality Monitoring	38
Activity Monitoring	39
Frequency Monitoring	39
Modes of Operation	41
Free-run mode	41
Pre-Locked mode	41
Locked mode	41
Lost_Phase mode	41
Holdover mode	42
Pre-Locked(2) mode	42
Protection Facility	43
Alignment of Priority Tables in Master and Slave ACS8510	44
Alignment of the Selection of Reference Sources for TOUT4 Generation in the Master and Slave ACS8510	45
Alignment of the Phases of the 8KHz and 2KHz Clocks in both Master and Slave ACS8510	45
JTAG	45
PORB	45
Electrical Specification	48

DC Characteristics: AMI Input/Output Port	54
Microprocessor Interface Timing	63
Motorola Mode	63
Intel Mode	65
Multiplexed Mode	67
Serial Mode	69
EPROM Mode	71
Package Information	72
Thermal Conditions	73
Application Information	74
Revision History	75
Ordering Information	76
Disclaimers	76

List of Figures

Figure 1. Simple Block Diagram	1
Figure 2. ACS8510 Pin Diagram	5
Figure 3. Minimum Input Jitter Tolerance (OC-3/STM-1)	15
Figure 4. Minimum Input Jitter Tolerance (DS1/E1)	16
Figure 5. Wander and Jitter Measured Transfer Characteristics	18
Figure 6. Maximum Time Interval Error of TOUT0 output port	20
Figure 7. Time Deviation of TOUT0 output port	20
Figure 8. Phase error accumulation of TOUT0 output port in Holdover mode	20
Figure 9. Inactivity and Irregularity Monitoring	38
Figure 10. Master-Slave Schematic	46
Figure 11. Automatic Mode Control State Diagram	47
Figure 12. Recommended Line Termination for PECL Input/Output Ports	51
Figure 13. Recommended Line Termination for LVDS Input/Output Ports	53
Figure 14. Signal Structure of 64 kHz/8kHz Central Clock Interface	55
Figure 15. AMI Input and Output Signal Levels	55
Figure 16. Recommended Line Termination for AMI Output/Output Ports	56
Figure 17. JTAG Timing	61
Figure 18. Input/Output Timing	62
Figure 19. Read Access Timing in MOTOROLA Mode	63
Figure 20. Write Access Timing in MOTOROLA Mode	64
Figure 21. Read Access Timing in INTEL Mode	65
Figure 22. Write Access Timing in INTEL Mode	66
Figure 23. Read Access Timing in MULTIPLEXED Mode	67
Figure 24. Write Access Timing in MULTIPLEXED Mode	68
Figure 25. Read Access Timing in SERIAL Mode	69
Figure 26. Write Access Timing in SERIAL Mode	70
Figure 27. Access Timing in EPROM Mode	71
Figure 28. LQFP Package	72
Figure 29. Typical 100 Pin LQFP Footprint	73
Figure 30. Simplified Application Schematic	74

List of Tables

Table 1. Power Pins	6
Table 2. No Connections	6
Table 3. Other Pins	7
Table 4. Input Reference Source Selection and Priority Table	12
Table 5. Input Reference Source Jitter Tolerance	14
Table 6. Amplitude and Frequency Values for Jitter Tolerance	15
Table 7. Amplitude and Frequency Values for Jitter Tolerance	16
Table 8. Output Reference Source Selection Table	17
Table 9. Multiple E1/DS1 Output in Relation to Normal Outputs	17
Table 10. Microprocessor Interface Mode Selection	21
Table 11. Register Map	23
Table 12. Register Map Description	27
Table 13. Master-Slave Relationship	46
Table 14. Absolute Maximum Ratings	48
Table 15. Operating Conditions	48
Table 16. DC Characteristics: TTL Input Port	48
Table 17. DC Characteristics: TTL Input Port with Internal Pull-up	49
Table 18. DC Characteristics: TTL Input Port with Internal Pull-down	49
Table 18. DC Characteristics: TTL Output Port	49
Table 20. DC Characteristics: PECL Input/Output Port	50
Table 21. DC Characteristics: LVDS Input/Output Port	52
Table 22. DC Characteristics: AMI Input/Output Port	54
Table 23. DC Characteristics: Output Jitter Generation (Test Definition G.813)	57
Table 24. DC Characteristics: Output Jitter Generation (Test Definition G.812)	57
Table 25. DC Characteristics: Output Jitter Generation (Test Definition ETS-300-462-3)	58
Table 26. DC Characteristics: Output Jitter Generation (Test Definition GR-253-CORE)	58
Table 27. DC Characteristics: Output Jitter Generation (Test Definition AT&T 62411)	59
Table 28. DC Characteristics: Output Jitter Generation (Test Definition G.742)	59
Table 29. DC Characteristics: Output Jitter Generation (Test Definition TR-NWT-000499)	59
Table 30. DC Characteristics: Output Jitter Generation (Test Definition GR-1244-CORE)	60
Table 31. JTAG Timing (for use with Figure 17)	61
Table 32. Read Access Timing in MOTOROLA Mode (for use with Figure 19)	63
Table 33. Write Access Timing in MOTOROLA Mode (for use with Figure 20)	64
Table 34. Read Access Timing in INTEL Mode (for use with Figure 21)	65
Table 35. Write Access Timing in INTEL Mode (for use with Figure 22)	66
Table 36. Read Access Timing in MULTIPLEXED Mode (for use with Figure 23)	67
Table 37. Write Access Timing in MULTIPLEXED Mode (for use with Figure 24)	68
Table 38. Read Access Timing in SERIAL Mode (for use with Figure 25)	70
Table 39. Write Access Timing in SERIAL Mode (for use with Figure 26)	70
Table 40. Access Timing in EPROM Mode (for use with Figure 27)	71
Table 41. 100 Pin LQFP Package Dimension Data (for use with Figure 28)	73

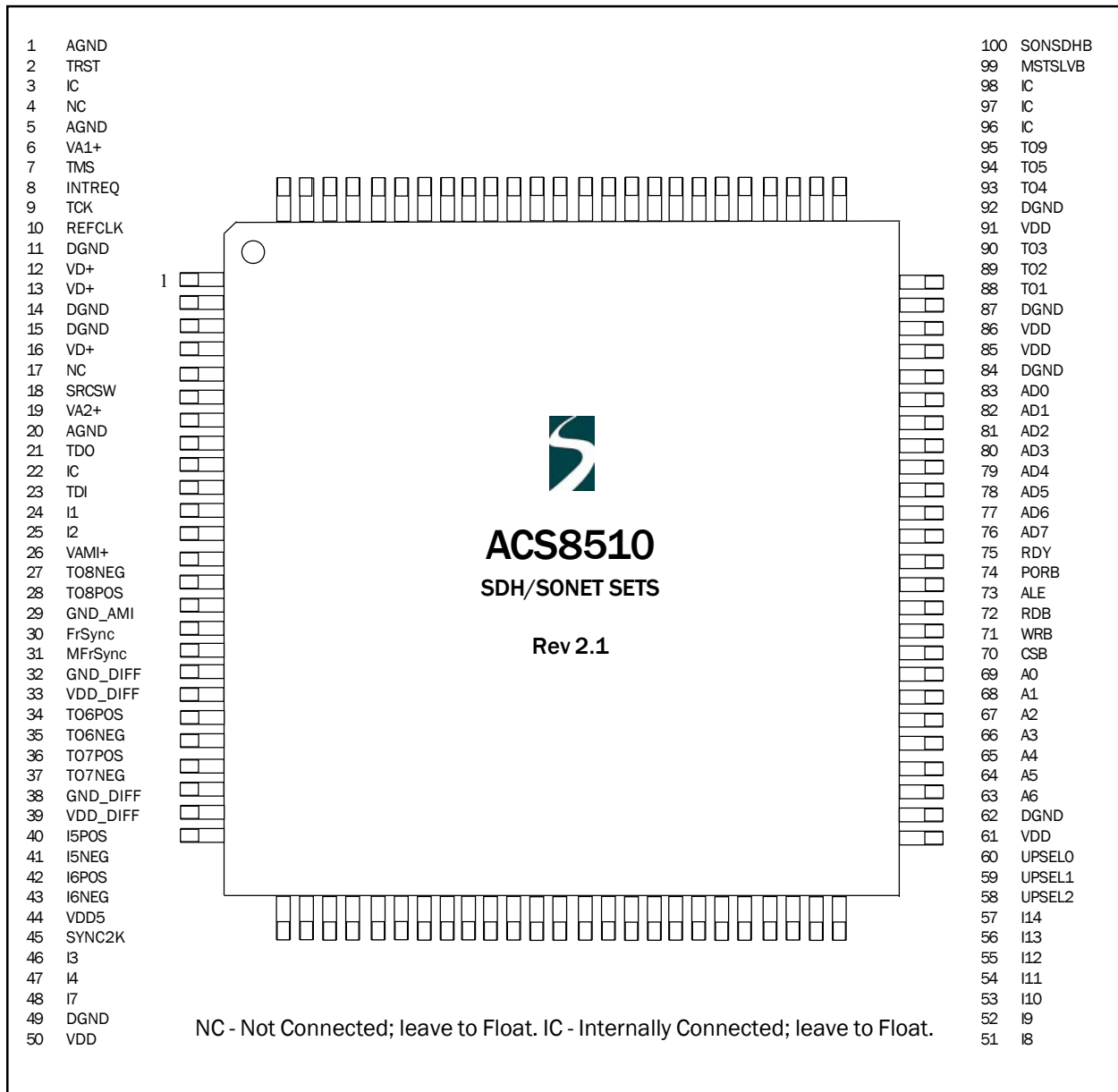
Pin Diagram
Figure 2. ACS8510 Pin Diagram

Pin Descriptions

Table 1. Power Pins

PIN	SYMBOL	IO	TYPE	NAME/DESCRIPTION
12, 13, 16	VD+	P	-	Supply voltage: Digital supply to gates in analog section, +3.3 Volts. +/- 10%
26	VAMI+	P	-	Supply voltage : Digital supply to AMI output, +3.3 Volts. +/- 10%
33, 39	VDD_DIFF	P	-	Supply voltage : Digital supply for differential ports, +3.3 Volts. +/- 10%
44	VDD5	P	-	VDD5: Digital supply for +5 Volts tolerance to input pins. Connect to +5 Volts (+/- 10%) for clamping to +5 Volts. Connect to VDD for clamping to +3.3 Volts. Leave floating for no clamping, input pins tolerant up to +5.5 Volts.
50, 61, 85, 86, 91	VDD	P	-	Supply voltage : Digital supply to logic, +3.3 Volts. +/- 10%
6	VA1+	P	-	Supply voltage: Analog supply to clock multiplying PLL, +3.3 Volts. +/- 10%
19	VA2+	P	-	Supply voltage : Analog supply to output PLL, +3.3 Volts. +/- 10%
11, 14, 15, 49, 62, 84, 87, 92	DGND	P	-	Supply Ground: Digital ground for logic
29	GND_AMI	P	-	Supply Ground: Digital ground for AMI output
32, 38	GND_DIFF	P	-	Supply Ground: Digital ground for differential ports
1, 5, 20	AGND	P	-	Supply Ground: Analog ground

Table 2. No Connections

PIN	SYMBOL	IO	TYPE	NAME/DESCRIPTION
4, 17	NC	-	-	Not Connected: Leave to Float
3, 22, 96, 97, 98	IC	-	-	Internally Connected: Leave to Float

Note: I = input, O = output, P = power, TTL^U = TTL input with pull-up resistor, TTL_D = TTL input with pull-down resistor

Table 3. Other Pins

PIN	SYMBOL	IO	TYPE	NAME/DESCRIPTION
2	TRST	I	TTL _D	JTAG Control Reset Input: TRST = 1 to enable JTAG Boundary Scan mode. TRST = 0 for normal device operation (JTAG logic transparent). If not used connect to GND or leave floating.
7	TMS	I	TTL ^U	JTAG Test Mode Select: Boundary Scan enable. Sampled on rising edge of TCK. If not used connect to VDD or leave floating.
8	INTREQ	O	TTL CMOS	Interrupt Request: Active high software Interrupt output
9	TCK	I	TTL _D	JTAG Clock: Boundary Scan clock input. If not used connect to GND or leave floating. This pin may require a capacitor placed between the pin and the nearest GND, to reduce noise pickup. A value of 10 pF should be adequate, but the value is dependent on PCB layout.
10	REFCLK	I	TTL	Reference Clock: 12.8 MHz (refer to section headed Local Oscillator Clock)
18	SRCSW	I	TTL _D	Source Switching: Force Fast Source Switching
21	TDO	O	TTL CMOS	JTAG Output: Serial test data output. Updated on falling edge of TCK. If not used leave floating.
23	TDI	I	TTL ^U	JTAG Input: Serial test data Input. Sampled on rising edge of TCK. If not used connect to VDD or leave floating.
24	I1	I	AMI	Input reference 1: composite clock 64 kHz + 8 kHz
25	I2	I	AMI	Input reference 2: composite clock 64 kHz + 8 kHz
27	T08NEG	O	AMI	Output reference 8: composite clock, 64 kHz + 8 kHz negative pulse
28	T08POS	O	AMI	Output reference 8: composite clock, 64 kHz + 8 kHz positive pulse
30	FrSync	O	TTL CMOS	Output reference 10: 8 kHz Frame Sync clock output (square wave)
31	MFrSync	O	TTL CMOS	Output reference 11: 2 kHz Multi-Frame Sync clock output (square wave)
34 35	T06POS T06NEG	O	LVDS PECL	Output reference 6: default 38.88 MHz. Also Dig1 (1.544 MHz/2.048 MHz and 2, 4, 8 x), 19.44 MHz, 155.52 MHz, 311.04 MHz. Default type LVDS.
36 37	T07POS T07NEG	O	PECL LVDS	Output reference 7: default 19.44 MHz. Also 51.84 MHz, 77.76 MHz, 155.52 MHz. Default type PECL.
40 41	I5POS I5NEG	I	LVDS PECL	Input reference 5: default 19.44 MHz, default type LVDS
42 43	I6POS I6NEG	I	PECL LVDS	Input reference 6: default 19.44 MHz, default type PECL

Table 3. Other Pins (continued)

PIN	SYMBOL	IO	TYPE	NAME/DESCRIPTION
45	SYNC2K	I	TTL _D	Synchronise 2 kHz: Connect to 2 kHz Multi-Frame Sync output of partner ACS8510 in redundancy system
46	I3	I	TTL _D	Input reference 3: programmable, default 8 kHz
47	I4	I	TTL _D	Input reference 4: programmable, default 8 kHz
48	I7	I	TTL _D	Input reference 7: programmable, default 19.44 MHz
51	I8	I	TTL _D	Input reference 8: programmable, default 19.44 MHz
52	I9	I	TTL _D	Input reference 9: programmable, default 19.44 MHz
53	I10	I	TTL _D	Input reference 10: programmable, default 19.44 MHz.
54	I11	I	TTL _D	Input reference 11: programmable, default (master mode)1.544/2.048 MHz, default (slave mode) 6.48 MHz
55	I12	I	TTL _D	Input reference 12: programmable, default 1.544/2.048 MHz.
56	I13	I	TTL _D	Input reference 13: programmable, default 1.544/2.048 MHz.
57	I14	I	TTL _D	Input reference 14: programmable, default 1.544/2.048 MHz.
58 - 60	UPSEL(2:0)	I	TTL _D	Microprocessor select: Configures the interface for a particular microprocessor type.
63 - 69	A(6:0)	I	TTL _D	Microprocessor Interface Address: Address bus for the microprocessor interface registers. A(0) is SDI in Serial mode.
70	CSB	I	TTL ^U	Chip Select (Active Low): This pin is asserted Low by the microprocessor to enable the microprocessor interface.
71	WRB	I	TTL ^U	Write (Active Low): This pin is asserted Low by the microprocessor to initiate a write cycle. In Motorola mode, WRB = 1 for Read.
72	RDB	I	TTL ^U	Read (Active Low): This pin is asserted Low by the microprocessor to initiate a read cycle.
73	ALE	I	TTL _D	Address Latch Enable: This pin becomes the address latch enable from the microprocessor. When this pin transitions from Low to High, the address bus inputs are latched into the internal registers. ALE = SCLK in Serial mode.
74	PORB	I	TTL ^U	Power On Reset: Master reset. If PORB is forced Low, all internal states are reset back to default values.
75	RDY	O	TTL CMOS	Ready/Data acknowledge: This pin is asserted High to indicate the device has completed a read or write operation.
76 - 83	AD(7:0)	IO	TTL _D	Address/Data: Multiplexed data/address bus depending on the microprocessor mode selection. AD(0) is SDO in Serial mode.

Table 3. Other Pins (continued)

PIN	SYMBOL	IO	TYPE	NAME/DESCRIPTION
88	T01	O	TTL CMOS	Output reference 1: default 6.48 MHz. Also Dig1 (1.544 MHz/2.048 MHz and 2, 4, 8 x), 19.44 MHz, 25.92 MHz
89	T02	O	TTL CMOS	Output reference 2: default 38.88 MHz. Also Dig2 (1.544 MHz/2.048 MHz and 2, 4, 8 x), 25.92 MHz, 51.84 MHz
90	T03	O	TTL CMOS	Output reference 3: 19.44 MHz - fixed.
93	T04	O	TTL CMOS	Output reference 4: 38.88 MHz - fixed.
94	T05	O	TTL CMOS	Output reference 5: 77.76 MHz - fixed.
95	T09	O	TTL CMOS	Output reference 9: 1.544/2.048 MHz. (T4 BITS)
99	MSTSLVB	I	TTL ^U	MASTERSLAVEB: Master slave select: sets the initial power up state (or state after a PORB) of the Master/Slave selection register, addr 34, bit 1. The register state can be changed after power up by software.
100	SONSDHB	I	TTL _D	SONETSDHB: SONET or SDH frequency select: sets the initial power up state (or state after a PORB) of the SONET/SDH frequency selection registers, addr 34h, bit 2 and addr 38, bits 5 and 6. The register states can be changed after power up by software.

Functional Description

The ACS8510 is a highly integrated, single-chip solution for the SETS function in a SONET/SDH Network Element, for the generation of SEC and frame synchronization pulses. In Free-run mode, the ACS8510 generates a stable, low-noise clock signal from an internal oscillator. In Locked mode, the ACS8510 selects the most appropriate input reference source and generates a stable, low-noise clock signal locked to the selected reference. In Holdover mode, the ACS8510 generates a stable, low-noise clock signal from the internal oscillator, adjusted to match the last known good frequency of the last selected reference source. In all modes, the frequency accuracy, jitter and drift performance of the clock meet the requirements of ITU G.812, G.813, G.823, and GR-1244-CORE.

The ACS8510 supports all three types of reference clock source: recovered line clock (T_{IN1}), PDH network synchronization timing (T_{IN2}) and node synchronization (T_{IN3}). The ACS8510 generates independent T_{OUT0} and T_{OUT4} clocks, an 8 kHz Frame Synchronization clock and a 2 kHz Multi-Frame Synchronization clock.

The ACS8510 has a high tolerance to input jitter and wander. The jitter/wander transfer is programmable (0.1 Hz up to 20 Hz cut-off points).

The ACS8510 supports protection. Two ACS8510 devices can be configured to provide protection against a single ACS8510 failure. The protection maintains alignment of the two ACS8510 devices (Master and Slave) and ensures that both ACS8510 devices maintain the same priority table, choose the same

reference input and generate the T_{OUT0} clock, the 8 kHz Frame Synchronization clock and the 2 kHz Multi-Frame Synchronization clock with the same phase. The ACS8510 includes a microprocessor port, providing access to the configuration and status registers for device setup and monitoring.

Local Oscillator Clock

The Master system clock on the ACS8510 should be provided by an external clock oscillator of frequency 12.80 MHz. The clock specification is important for meeting the ITU/ETSI and Telcordia performance requirements for Holdover mode. ITU and ETSI specifications permit a combined drift characteristic, at constant temperature, of all non-temperature-related parameters, of up to 10 ppb per day. The same specifications allow a drift of 1 ppm over a temperature range of 0 to +70 °C. Telcordia specifications are somewhat tighter, requiring a non-temperature-related drift of less than 40 ppb per day and a drift of 280 ppb over the temperature range 0 to +50 °C.

ITU and ETSI Specification

Tolerance: +/- 4.6 ppm over 20 year life time.
Drift*:
+/- 0.05 ppm/15 seconds @ constant temp.
+/- 0.01 ppm/day @ constant temp.
+/- 1 ppm over temp. range 0 to +70 °C

*Frequency drift over supply range of +2.7V to +3.3V.

Telcordia GR-1244 CORE Specification

Tolerance: +/- 4.6 ppm over 20 year life time.
Drift*:
+/- 0.05 ppm/15 seconds @ constant temp.
+/- 0.04 ppm/day @ constant temp.
+/- 0.28 ppm over temp. range 0 to +50 °C

*Frequency drift over supply range of +2.7V to +3.3V.

Please contact Semtech for information on crystal oscillator suppliers.

Crystal Frequency Calibration

The absolute crystal frequency accuracy is less important than the stability since any frequency offset can be compensated by adjustment of register values in the IC. This allows for calibration and compensation of any crystal frequency variation away from its nominal value. +/- 50 ppm adjustment would be sufficient to cope with most crystals, in fact the range is an order of magnitude larger due to the use of two 8 bit register locations. The setting of the *conf_nominal_frequency* register allows for this adjustment. An increase in the register value increases the output frequencies by 0.02 ppm for each LSB step. The default value (in decimal) is 39321. The minimum being 0 and the maximum 65535, gives a -700 ppm to +500 ppm adjustment range of the output frequencies.

For example, if the crystal was oscillating at 12.8 MHz + 5 ppm, then the calibration value in the register to give a -5 ppm adjustment in output frequencies to compensate for the crystal inaccuracy, would be :

$$39321 - (5 / 0.02) = 39071 \text{ (decimal)}$$

Input Interfaces

The ACS8510 supports up to fourteen input reference clock sources from input types T_{IN1} , T_{IN2} and T_{IN3} using TTL, CMOS, PECL, LVDS and AMI buffer I/O technologies. These interface technologies support +3.3 V and +5 V operation.

Over-Voltage Protection

The ACS8510 may require Over-Voltage Protection on input reference clock ports according to ITU Recommendation K.41. Semtech protection devices are recommended for this purpose (see separate Semtech data book).

Input Reference Clock Ports

Table 4 gives details of the input reference ports, showing the input technologies and the range of frequencies supported on each port; the default spot frequencies and default priorities assigned to each port on power-up or by reset are also shown. Note that SDH and SONET networks use different default frequencies; the network type is pin-selectable (using the SONSDB pin). Specific frequencies and priorities are set by configuration.

Although each input port is shown as belonging to one of the types, T_{IN1} , T_{IN2} or T_{IN3} , they are fully interchangeable as long as the selected speed is within the maximum operating speed of the input port technology.

SDH and SONET networks use different default frequencies; the network type is selectable using the *config_mode* register 34 Hex, bit 2. For SONET, *config_mode* register 34 Hex, bit 2 = 1, for SDH *config_mode* register 34 Hex, bit 2 = 0. On power-up or by reset, the default will be set by the state of the SONSDB pin (pin 100). Specific frequencies and priorities are set by configuration.

TTL ports (compatible also with CMOS signals) support clock speeds up to 100 MHz, with the highest spot frequency being 77.76 MHz. The actual spot frequencies supported are:

- 2 kHz
- 4 kHz
- 8 kHz (and $N \times 8$ kHz)
- 1.544 MHz (SONET)/2.048 MHz (SDH)
- 6.48 MHz,
- 19.44 MHz,
- 25.92 MHz,
- 38.88 MHz,
- 51.84 MHz,
- 77.76 MHz.

The frequency selection is programmed via the *cnfg_ref_source_frequency* register. The internal DPLL will normally lock to the selected input at the frequency of the input, eg. 19.44 MHz will lock the DPLL phase comparisons at 19.44 MHz. It is, however, possible to utilise an internal pre-divider to the DPLL to divide the input frequency before it is used for phase comparisons in the DPLL. This pre-divider can be used in one of 2 ways:

1. Any of the supported spot frequencies can be divided to 8 kHz by setting the 'lock8K' bit (bit 6) in the appropriate *cnfg_ref_source_frequency* register location. For good jitter tolerance for all frequencies and for operation at 19.44 MHz and above, use lock8K. It is possible to choose which edge of the 8kHz input to lock to, by setting the appropriate bit of the *cnfg_control1* register.

2. Any multiple of 8 kHz between 1544 kHz to 100 MHz can be supported by using the 'DivN' feature (bit 7 of the *cnfg_ref_source_frequency* register). Any reference input can be set to use DivN independently of the frequencies and configurations of the other inputs.

Any reference input with the DivN bit set in the *cnfg_ref_source_frequency* register will employ the internal pre-divider prior to the DPLL locking. The *cnfg_freq_divn* register contains the divider ratio N where the reference input will get divided by $(N+1)$ where $0 < N < 2^{14}-1$. The *cnfg_ref_source_frequency* register must be set to the closest supported spot frequency to the input frequency, but must be lower than the input frequency. When using the DivN feature the post-divider frequency must be 8 kHz, which is indicated by setting the 'lock8k' bit high (bit 6 in *cnfg_ref_source_frequency* register). Any input set to DivN must have the frequency monitors disabled (If the frequency monitors are disabled, they are disabled for all inputs regardless of the input configurations, in this case only activity monitoring will take place). Whilst any number of inputs can be set to use the DivN feature, only one N can be programmed, hence all inputs using the DivN feature must require the same division to get to 8 kHz.

Table 4. Input Reference Source Selection and Priority Table

Port Number	Channel Number	Port Type	Input Port Technology	Frequencies Supported	Default Priority
I_1	0001	T _{IN3}	AMI	64/8kHz (composite clock, 64kHz + 8kHz) Default (SONET): 64/8kHz Default (SDH): 64/8kHz	2
I_2	0010	T _{IN3}	AMI	64/8kHz (composite clock, 64kHz + 8kHz) Default (SONET): 64/8kHz Default (SDH): 64/8kHz	3
I_3	0011	T _{IN3}	TTL/CMOS	Up to 100MHz (see Note 1) Default (SONET): 8kHz Default (SDH): 8kHz	4
I_4	0100	T _{IN3}	TTL/CMOS	Up to 100MHz (see Note 1) Default (SONET): 8kHz Default (SDH): 8kHz	5
I_5	0101	T _{IN1}	LVDS/PECL LVDS default	Up to 155.52MHz (see Note 2) Default (SONET): 19.44MHz Default (SDH): 19.44MHz	6
I_6	0110	T _{IN1}	PECL/LVDS PECL default	Up to 155.52MHz (see Note 2) Default (SONET): 19.44MHz Default (SDH): 19.44MHz	7
I_7	0111	T _{IN1}	TTL/CMOS	Up to 100MHz (see Note 1) Default (SONET): 19.44MHz Default (SDH): 19.44MHz	8
I_8	1000	T _{IN1}	TTL/CMOS	Up to 100MHz (see Note 1) Default (SONET): 19.44MHz Default (SDH): 19.44MHz	9
I_9	1001	T _{IN1}	TTL/CMOS	Up to 100MHz (see Note 1) Default (SONET): 19.44MHz Default (SDH): 19.44MHz	10
I_10	1010	T _{IN1}	TTL/CMOS	Up to 100MHz (see Note 1) Default (SONET): 19.44MHz Default (SDH): 19.44MHz	11
I_11	1011	T _{IN2}	TTL/CMOS	Up to 100MHz (see Note 1) Default (Master) (SONET): 1.544MHz Default (Master) (SDH): 2.048MHz Default (Slave) 6.48MHz	12/1 (Note 3)
I_12	1100	T _{IN2}	TTL/CMOS	Up to 100MHz (see Note 1) Default (SONET): 1.544MHz Default (SDH): 2.048MHz	13
I_13	1101	T _{IN2}	TTL/CMOS	Up to 100MHz (see Note 1) Default (SONET): 1.544MHz Default (SDH): 2.048MHz	14
I_14	1110	T _{IN2}	TTL/CMOS	Up to 100MHz (see Note 1) Default (SONET): 1.544MHz Default (SDH): 2.048MHz	15

Notes for Table 4.

Note 1: TTL ports (compatible also with CMOS signals) support clock speeds up to 100 MHz, with the highest spot frequency being 77.76 MHz. The actual spot frequencies are: 2 kHz, 4 kHz, 8 kHz (and N x 8 kHz), 1.544 MHz (SONET)/2.048 MHz (SDH), 6.48 MHz, 19.44 MHz, 25.92 MHz, 38.88 MHz, 51.84 MHz, 77.76 MHz. SONET or SDH is selected using the SONSDHB pin. When the SONSDHB pin is High SONET is selected, when the SONSDHB pin is Low SDH is selected.

Note 2: PECL and LVDS ports support the spot clock frequencies listed above plus 155.52 MHz and 311.04 MHz.

Note 3: Input port <I_11> is set at 12 on the Master SETS IC and 1 on the Slave SETS IC, as default on power up (or PORB). The default setup of Master or Slave <I_11> priority is determined by the MSTSLVB pin.

DivN examples

To lock to 2.000 MHz.

- (1) The *cnfg_ref_source_frequency* register is set to 11XX0001 (binary) to set the DivN, lock8k bits, and the frequency to E1/DS1. (XX = 'leaky bucket' ID for this input).
- (2) The *cnfg_mode* register (34Hex) bit 2 needs to be set to 1 to select SONET frequencies (DS1).
- (3) The frequency monitors are disabled in *cnfg_monitors* register (48Hex) by writing 00 to bits 0 and 1.
- (4) The DivN register is set to F9 Hex (249 decimal).

To lock to 10.000 MHz.

- (1) The *cnfg_ref_source_frequency* register is set to 11XX0010 (binary) to set the DivN, lock8k bits, and the frequency to 6.48 MHz. (XX = 'leaky bucket' ID for this input).
- (2) The frequency monitors are disabled in *cnfg_monitors* register (48Hex) by writing 00 to bits 0 and 1.
- (3) The DivN register is set to 4E1 Hex (1249 decimal).

PECL and LVDS ports support the spot clock frequencies listed plus 155.52 MHz and 311.04 MHz. The choice of PECL or LVDS compatibility is programmed via the *cnfg_differential_inputs* register. Unused PECL/LVDS differential inputs should be fixed with one input high (VDD) and the other input low (GND), or set in LVDS mode and left floating, in which case one input is internally pulled high and the other low.

An AMI port supports a composite clock, consisting of a 64 kHz AMI clock with 8 kHz boundaries marked by deliberate violations of the AMI coding rules, as specified in ITU recommendation G.703. Departures from the nominal pattern are detected within the

ACS8510, and may cause reference-switching if too frequent. See section DC Characteristics: AMI Input/Output Port, for more details. If the AMI port is unused, the pins (I1 and I2) should be tied to GND and the VAMI+ supply pin (pin 26) disconnected.

Input Wander and Jitter Tolerance

The ACS8510 is compliant to the requirements of all relevant standards, principally ITU Recommendation G.825, ANSI DS1.101-1994 and ETS 300 462-5 (1997).

All reference clock inputs have a tight frequency tolerance but a generous jitter tolerance. Pull-in, hold-in and pull-out ranges are specified for each input port in Table 5. Minimum jitter

tolerance masks are specified in Figures 3 and 4, and Tables 6 and 7, respectively. The ACS8510 will tolerate wander and jitter components greater than those shown in Figure 3 and Figure 4, up to a limit determined by a combination of the apparent long-term frequency offset caused by wander and the eye-closure caused by jitter (the input source will be rejected if the offset pushes the frequency outside the hold-in range for long enough to be detected, whilst the signal will also be rejected if the eye closes sufficiently to affect the signal purity). The '8klocking' mode should be engaged for high jitter tolerance according to these masks. All reference clock ports are monitored for quality, including frequency offset and general activity. Single short-term interruptions in selected reference clocks may not cause rearrangements, whilst longer interruptions, or multiple, short-term interruptions, will cause rearrangements, as will frequency offsets which are sufficiently large or sufficiently long to cause loss-of-lock in the

phase-locked loop. The failed reference source will be removed from the priority table and declared as unserviceable, until its perceived quality has been restored to an acceptable level.

The registers *sts_curr_inc_offset* (address 0C, 0D, 07) report the frequency of the DPLL with respect to the external TCXO frequency. This is a 19 bit signed number with one LSB representing 0.0003 ppm (range of +/- 80 ppm). Reading this regularly can show how the currently locked source is varying in value e.g. due to wander on its input.

The ACS8510 performs automatic frequency monitoring with an acceptable input frequency offset range of +/- 16.6 ppm. The ACS8510 DPLL has a programmable frequency limit of +/- 80 ppm. If the range is programmed to be > 16.6 ppm, the frequency monitors should be disabled so the input reference source is not automatically rejected as out of frequency range.

Table 5. Input Reference Source Jitter Tolerance

Jitter Tolerance	Frequency Monitor Acceptance Range	Frequency Acceptance Range (Pull-in)	Frequency Acceptance Range (Hold-in)	Frequency Acceptance Range (Pull-out)
G.703	+/- 16.6 ppm	+/- 4.6 ppm (see Note 1)	+/- 4.6 ppm (see Note 1)	+/- 4.6 ppm (see Note 1)
G.783				
G.823		+/- 9.2 ppm (see Note 2)	+/- 9.2 ppm (see Note 2)	+/- 9.2 ppm (see Note 2)
GR-1244-CORE				

Notes for Table 5.

Note 1. The frequency acceptance and generation range will be +/-4.6 ppm around the required frequency when the external crystal frequency accuracy is within a tolerance of +/- 4.6 ppm.

Note 2. The fundamental acceptance range and generation range is +/- 9.2 ppm with an exact external crystal frequency of 12.8 MHz. This is the default DPLL range, the range is also programmable from 0 to 80 ppm in 0.08 ppm steps.

Figure 3. Minimum Input Jitter Tolerance (OC-3/STM-1)

(for inputs supporting G.783 compliant sources)



Table 6. Amplitude and Frequency Values for Jitter Tolerance

STM level	Peak to peak amplitude (unit Interval)					Frequency (Hz)									
	A0	A1	A2	A3	A4	F0	F1	F2	F3	F4	F5	F6	F7	F8	F9
STM-1	2800	311	39	1.5	0.15	12u	178u	1.6m	15.6m	0.125	19.3	500	6.5k	65k	1.3m

Output Clock Ports

The device supports a set of main output clocks, T_{OUT0} and T_{OUT4} , and a pair of secondary output clocks, 'Frame-Sync' and 'Multi-Frame-Sync'. The two main output clocks, T_{OUT0} and T_{OUT4} , are independent of each other and are individually selectable. The two secondary output clocks, 'Frame-Sync' and 'Multi-Frame-Sync', are derived from T_{OUT0} . The frequencies of the output clocks are selectable from a range of pre-defined spot frequencies and a variety of output technologies are supported, as defined in Table 8.

Low-speed Output Clock (T_{OUT4})

The T_{OUT4} clock is supplied on two output ports, T_{O8} and T_{O9} . The former port will provide an AMI signal carrying a composite clock of 64 kHz and 8 kHz, according to ITU Recommendation

G.703. The latter port will provide a TTL/CMOS signal at either 1.544 MHz or 2.048 MHz, depending on the setting of the SONSDHB pin.

High-speed Output Clock (Part of T_{OUT0})

The T_{OUT0} port has multiple outputs. Outputs T_{O1} and T_{O2} are TTL/CMOS output with a choice of 11 different frequencies up to 51.84 MHz. Outputs T_{O3} to T_{O5} are all TTL/CMOS outputs with fixed frequencies of 19.44 MHz, 38.88 MHz and 77.76 MHz respectively. Output T_{O6} is differential and can support clocks up to 155.52 MHz. Output T_{O7} is also differential and can support clocks up to 155.52 MHz. Each output is individually configured to operate at the frequencies shown in Table 8 (configuration must be consistent between ACS8510 devices for protection-switching to be effective - output clocks will be phase-aligned

Figure 4. Minimum Input Jitter Tolerance (DS1/E1)

(for inputs supporting G.783 compliant sources)

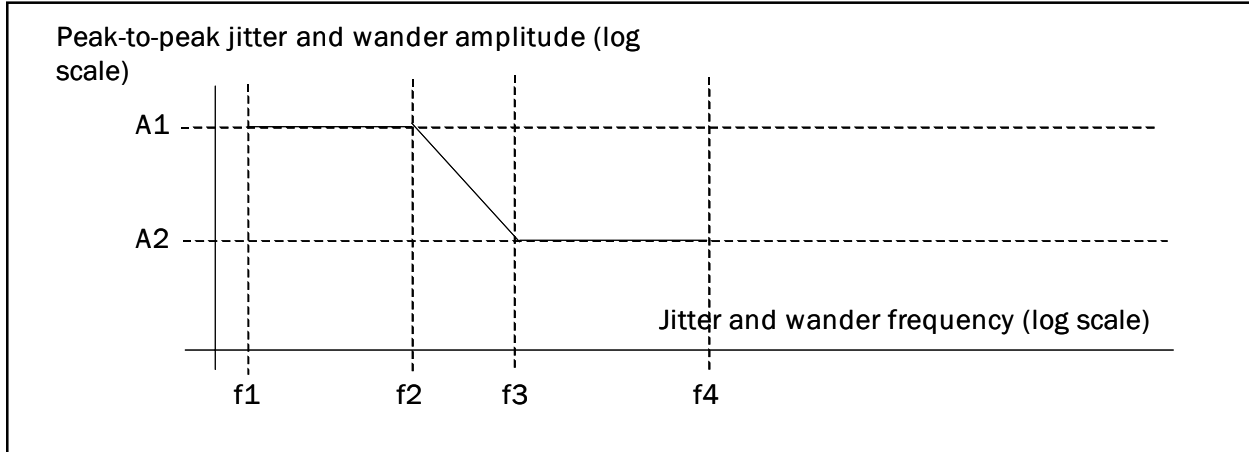

Table 7. Amplitude and Frequency Values for Jitter Tolerance

Type	Spec.	Amplitude (UI pk-pk)		Frequency (Hz)			
		A1	A2	F1	F2	F3	F4
DS1	GR-1244-CORE	5	0.1	10	500	8k	40k
E1	ITU G.823	1.5	0.2	20	2.4k	18k	100k

between devices). Using the *cnfg_differential_outputs* register, outputs T_{06} and T_{07} can be made to be LVDS or PECL compatible.

Frame Sync and Multi-Frame Sync Clocks (Part of T_{OUT0})

Frame Sync (8 kHz) and Multi-Frame Sync (2 kHz) clocks are provided on outputs T_{010} (FrSync) and T_{011} (MFrSync). The FrSync and MFrSync clocks have a 50:50 mark space ratio. These are driven from the T_{OUT0} clock. They are synchronized with their counterparts in a second ACS8510 device (if used), using the technique described later.

Low Jitter Multiple E1/DS1 Outputs

This feature added to Rev2.1 is activated using the *cnfg_control1* register. This sends a frequency of twice the Dig2 rate (see reg addr 39h, bits 7:6) to the APLL instead of the normal 77.76MHz. For this feature to be used, the Dig2 rate must only be set to 12352kHz/16384kHz using the *cnfg_TO_output_frequencies* register. The normal OC3 rate outputs are then replaced with E1/DS1 multiple rates. The E1(SONET)/DS1(SDH) selection is made in the same way as for Dig2 using the *cnfg_TO_output_enable* register. Table 9 shows the relationship between primary output frequencies and the corresponding output in E1/DS1 mode, and which output they are available from.

Output Wander and Jitter

Wander and jitter present on the output clocks are dependent on:

1. The magnitude of wander and jitter on the selected input reference clock (in Locked mode)
2. The internal wander and jitter transfer characteristic (in Locked mode)
3. The jitter on the local oscillator clock
4. The wander on the local oscillator clock (in Holdover mode)

Wander and jitter are treated in different ways to reflect their differing impacts on network design. Jitter is always strongly attenuated, whilst wander attenuation can be varied to suit the application and operating state. Wander and jitter attenuation is performed using a digital phase locked loop (DPLL) with a programmable bandwidth. This gives a transfer characteristic of a low pass filter, with a programmable pole. It is sometimes necessary to change the filter dynamics to suit particular circumstances - one example being when locking to a new source,

Table 8. Output Reference Source Selection Table

Port Name	Output Port Technology	Frequencies Supported
T ₀₁	TTL/CMOS	1.544 MHz/2.048 MHz, 3.088 MHz/4.096 MHz, 6.176 MHz/8.192 MHz, 6.48 MHz (default), 12.352 MHz/16.384 MHz, 19.44 MHz, 25.92 MHz
T ₀₂	TTL/CMOS	1.544 MHz/2.048 MHz, 3.088 MHz/4.096 MHz, 6.176 MHz/8.192 MHz, 12.352 MHz/16.384 MHz, 25.92 MHz, 38.88 MHz (default), 51.84 MHz
T ₀₃	TTL/CMOS	19.44 MHz - fixed
T ₀₄	TTL/CMOS	38.88 MHz - fixed
T ₀₅	TTL/CMOS	77.76 MHz - fixed
T ₀₆	LVDS/PECL (LVDS default)	1.544 MHz/2.048 MHz, 3.088 MHz/4.096 MHz, 6.176 MHz/8.192 MHz, 12.352 MHz/16.384 MHz, 19.44 MHz, 38.88 MHz (default), 155.52 MHz, 311.04 MHz
T ₀₇	PECL/LVDS (PECL default)	19.44 MHz (default), 51.84 MHz, 77.76 MHz, 155.52 MHz
T ₀₈	AMI	64/8 kHz (composite clock, 64 kHz + 8 kHz)
T ₀₉	TTL/CMOS	1.544 MHz/2.048 MHz
T ₀₁₀	TTL/CMOS	FrSync, 8 kHz - with a 50:50 MSR
T ₀₁₁	TTL/CMOS	MFrSync, 2 kHz - with a 50:50 MSR

Note for Table 8.

Where 1.544 MHz/2.048 MHz is shown, 1.544 MHz is SONET, and 2.048 MHz is SDH. Pin SONSDHB controls the default frequency output. Where the SONSDHB pin is High SONET is default, and when SONSDHB pin is Low SDH is default.

Table 9. Multiple E1/DS1 Outputs in relation to Standard Outputs

Mode	Freq to APLL	APLL Multiplier	APLL Freq	clk_filt	clk_filt/2	clk_filt/4	clk_filt/6	clk_filt/8	clk_filt/12	clk_filt/16	clk_filt/48	DPLL Freq
Default	77.76	4	311.04	311.04	155.52	77.76	51.84	38.88	25.92	19.44	6.48	77.76
n value						16		8		4		
n x E1	32.768	4	131.072	131.072	65.536	32.768	21.84533	16.384	10.92267	8.192	2.730667	77.76
n x T1	24.704	4	98.816	98.816	49.408	24.704	16.46933	12.352	8.234667	6.176	2.058667	77.76

Frequencies Available by Output

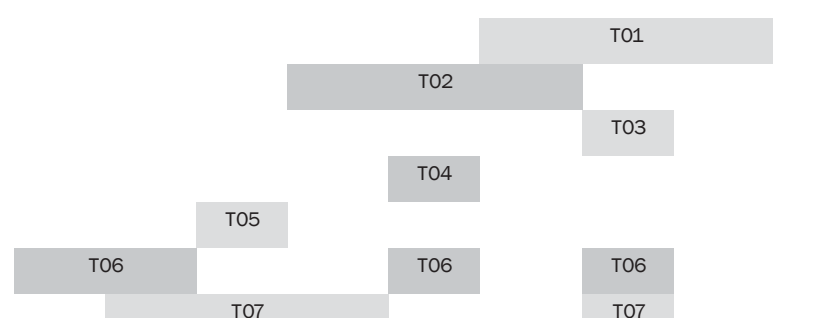

the filter can be opened up to reduce locking time and can then be gradually tightened again to remove wander. Since wander represents a relatively long-term deviation from the nominal operating frequency, it affects the rate of supply of data to the network element. Strong wander attenuation limits the rate of consumption of data to within a smaller range, so a larger buffer store is required to prevent data loss. But, since any buffer store potentially increases latency, wander may often only need to be removed at specific points within a network where buffer stores are acceptable, such as at digital cross connects. Otherwise, wander is sometimes not required to be attenuated and can be passed through transparently. The ACS8510 has programmable wander transfer characteristics in a range from 0.1 Hz to 20 Hz. The wander and jitter transfer characteristic is shown in Figure 5.

Wander on the local oscillator clock will not have significant effect on the output clock whilst in Locked mode, so long as the DPLL bandwidth is set high enough so that the DPLL can compensate quickly enough for any frequency changes in the crystal. In Free-run or Holdover mode wander on the crystal is more significant.

Variation in crystal temperature or supply voltage both cause drifts in operating frequency, as does ageing. These effects must be limited by careful selection of a suitable component for the local oscillator, as specified in the section 'Local Oscillator Clock'.

Phase Variation

There will be a phase shift across the ACS8510 between the selected input reference source and the output clock. This phase shift may vary over time but will be constrained to lie within specified limits. The phase shift is characterised using two parameters, MTIE (Maximum Time Interval Error), and TDEV (Time Deviation), which, although being specified in all relevant specifications, differ in acceptable limits in each one. Typical measurements for the ACS8510 are shown in Figures 6 and 7, for Locked mode operation. Figure 8 shows a typical measurement of Phase Error accumulation in Holdover mode operation.

The required performance for phase variation during Holdover is specified in several ways depending upon the particular circumstances pertaining:

Figure 5. Wander and Jitter Measured Transfer Characteristics

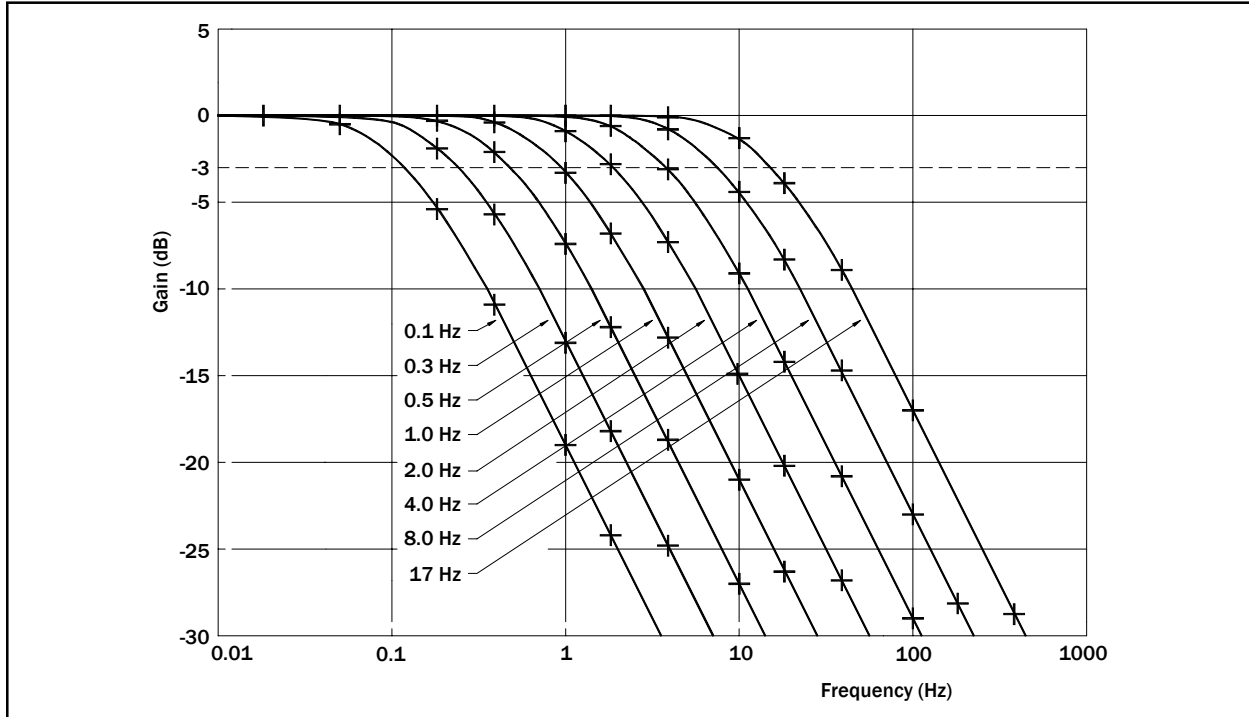

1. ETSI 300 462-5, Section 9.1, requires that the short-term phase error during switchover (i.e., Locked to Holdover to Locked) be limited to an accumulation rate no greater than 0.05 ppm during a 15 second interval.

2. ETSI 300 462-5, Section 9.2, requires that the long-term phase error in the Holdover mode should not exceed

$$\{(a1+a2)S+0.5bS^2+c\}$$

where

a1 = 50 ns/s (allowance for initial frequency offset)

a2 = 2000 ns/s (allowance for temperature variation)

b = 1.16×10^{-4} ns/s² (allowance for ageing)

c = 120 ns (allowance for entry into Holdover mode).

3. ANSI Tin1.101-1994, Section 8.2.2, requires that the phase variation be limited so that no more than 255 slips (of 125 μ s each) occur during the first day of Holdover. This requires a frequency accuracy better than:

$$((24 \times 60 \times 60) + (255 \times 125 \mu\text{s})) / (24 \times 60 \times 60) = 0.37 \text{ ppm}$$

Temperature variation is not restricted, except to within the normal bounds of 0 to 50 °C.

4. Telcordia GR.1244.CORE, Section 5.2., Table 4, shows that an initial frequency offset of 50 ppb is permitted on entering Holdover, whilst a drift over temperature of 280 ppb is allowed; an allowance of 40 ppb is permitted for all other effects.

5. ITU G.822, Section 2.6, requires that the slip rate during category(b) operation (interpreted as being applicable to Holdover mode operation) be limited to less than 30 slips (of 125 μ s each) per hour

$$(((60 \times 60) / 30) + 125 \mu\text{s}) / (60 \times 60) = 1.042 \text{ ppm}$$

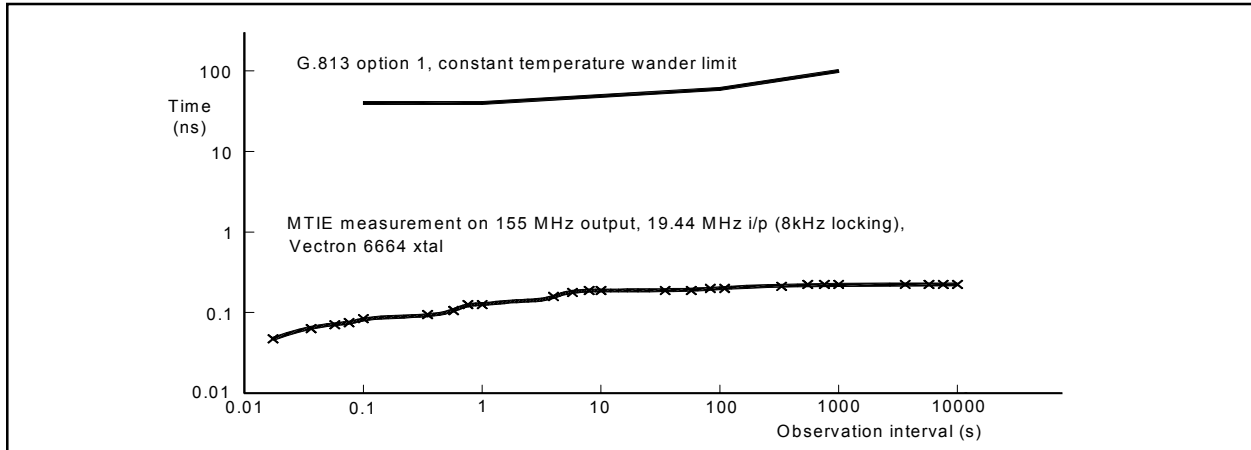
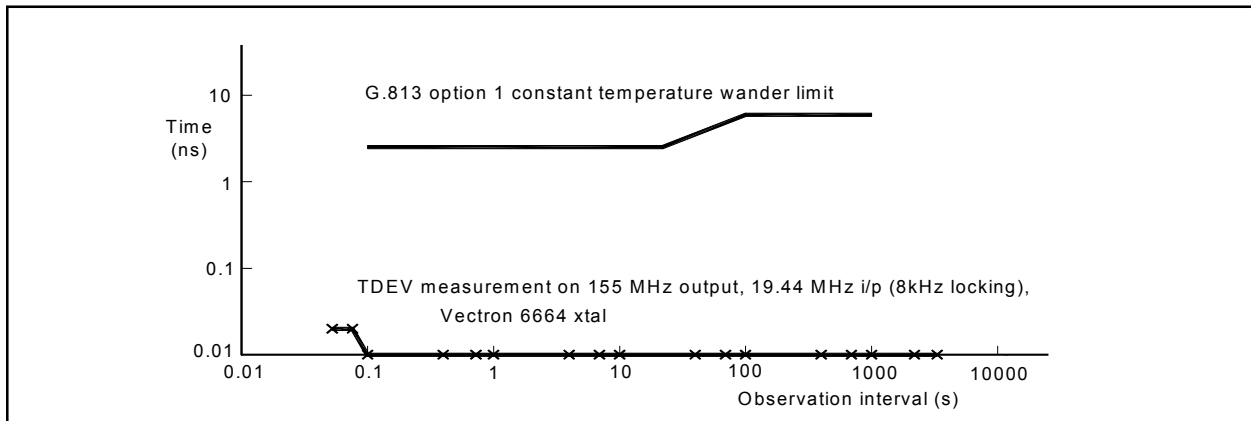
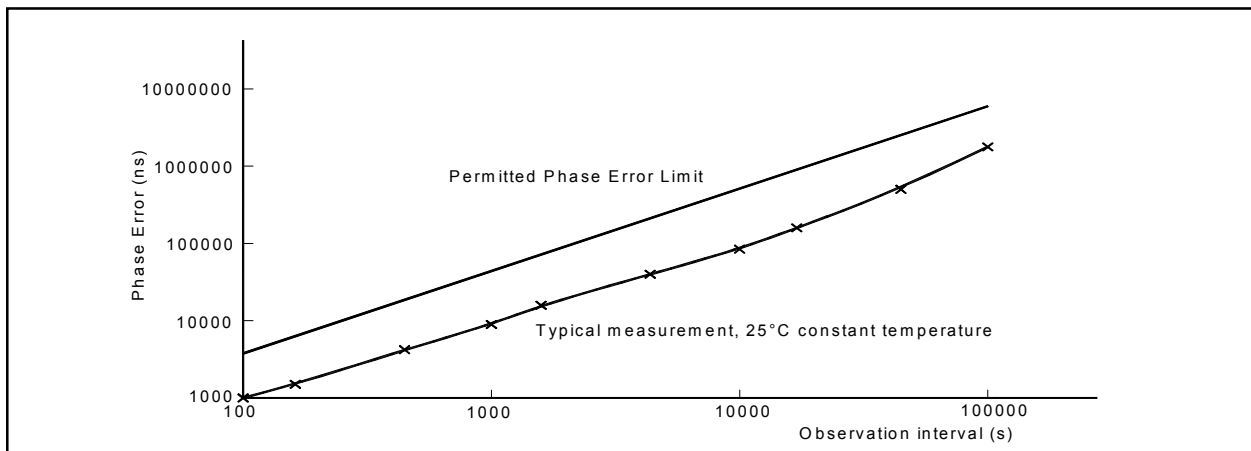
Figure 6. Maximum Time Interval Error of T_{OUT0} output port

Figure 7. Time Deviation of T_{OUT0} output port

Figure 8. Phase error accumulation of T_{OUT0} output port in Holdover mode

Phase Build Out

Phase Build Out (PBO) is the function to minimise phase transients on the output SEC clock during input reference switching. If the currently selected input reference clock source is lost (due to a short interruption, out of frequency detection, or complete loss of reference), the second, next highest priority reference source will be selected. During this transition, the Lost_Phase mode is entered.

The typical phase disturbance on clock reference source switching will be less than 12 ns on the ACS8510. For clock reference switching caused by the main input failing or being disconnected, then the phase disturbance on the output will still be less than the 120 ns allowed for in the G.813 spec. The actual value is dependent on the frequency being locked to.

ITU-T G.813 states that the max allowable short term phase transient response, resulting from a switch from one clock source to another, with Holdover mode entered in between, should be a maximum of 1 μ s over a 15 second interval. The maximum phase transient or jump should be less than 120 ns at a rate of change of less than 7.5 ppm and the Holdover performance should be better than 0.05 ppm.

On the ACS8510, PBO can be enabled, disabled or frozen using the μ P interface. By default, it is enabled. When PBO is enabled, it can also be frozen, which will disable the PBO operation on the next input reference switch, but will remain with the current offset. If PBO is disabled while the device is in the Locked mode, there will be a phase jump on the output SEC clocks as the DPLL locks back to 0 degree phase error.

Microprocessor Interface

The ACS8510 incorporates a microprocessor interface, which can be configured for the following modes via the bus interface mode control pins UPSEL(2:0) as defined in Table 10.

Table 10. Microprocessor Interface Mode Selection

UPSEL(2:0)	Mode	Description
111 (7)	OFF	Interface disabled
110 (6)	OFF	Interface disabled
101 (5)	SERIAL	Serial μ P bus interface
100 (4)	MOTOROLA	Motorola interface
011 (3)	INTEL	Intel compatible bus interface
010 (2)	MULTIPLEXED	Multiplexed bus interface
001 (1)	EPROM	EPROM read mode
000 (0)	OFF	Interface disabled

Motorola Mode

Parallel data + address: this mode is suitable for use with Motorola's 68x0 type bus.

Intel Mode

Parallel data + address: this mode is suitable for use with Intel's 80x86 type bus.

Multiplexed Mode

Data/address: this mode is suitable for use with microprocessors which share bus signals between address and data (e.g., Intel's 80x86 family).

Serial Mode

This mode is suitable for use with micro-processor which use a serial interface.

EPROM Mode

This mode is suitable for simple standalone applications where it is required to change the default loading of the register values to suit different applications.

This can be done by loading values from an external ROM. The data is read from the ROM automatically after power up when the UPSEL(2:0) pins are set to '001'. Each register value is stored sequentially, with ROM address 0 corresponding to register address 0 and so on.

The value in the 'chip_id' location (address 00 & 01) is checked to see if it matches the ID number of the ACS8510 V2 (value 213E). Upon a successful number match, the remaining data

from the ROM is used to set the internal register values. Only 64 locations in the ROM are required.

Register Set

All registers are 8-bits wide, organised with the most-significant bit positioned in the left-most bit, with bit significance decreasing towards the right most bit. Some registers carry several individual data fields of various sizes, from single-bit values (e.g. flags) upwards. Several data fields are spread across multiple registers; their organisation is shown in the register map, Table 11.

Configuration Registers

Each configuration register reverts to a default value on power-up or following a reset. Most default values are fixed, but some will be pin-settable. All configuration registers can be read out over the microprocessor port.

Status Registers

The Status Registers contain readable registers. They may all be read from outside the chip but are not writeable from outside the chip (except for a clearing operation). All status registers are read via shadow registers to avoid data hits due to dynamic operation. Each individual status register has a unique location.

Register Access

Most registers are of one of two types, configuration registers or status registers, the exceptions being the *chip_ID* and *chip_revision* registers. Configuration registers may be written to or read from at any time (the complete 8-bit register must be written, even if only one bit is being modified). All status registers may be read at any time and, in some status registers (such as the *sts_interrupts* register), any individual data field may be cleared by writing a '1' into each bit of the field (writing a '0' value into a bit will not affect the value of the bit). A description of each register is given in the Register Map, and Register Map Description.

Interrupt Enable and Clear

Interrupt requests are flagged on pin INTREQ (active High). Bits in the interrupt status register are set (high) by the following conditions:

1. Any reference source becoming valid or going invalid
2. A change in the operating state (eg. Locked, Holdover etc.)
3. A brief loss of the currently selected reference source
4. An AMI input error

All interrupt sources are maskable via the mask register, each one being enabled by writing a '1' to the appropriate bit. Any unmasked bit set in the interrupt status register will cause the interrupt request pin to be asserted (high). All interrupts are cleared by writing a '1' to the bit(s) to be cleared in the status register. When all pending unmasked interrupts are cleared the interrupt pin will go inactive (low).

The loss of the currently selected reference source will eventually cause the input to be considered invalid, triggering an interrupt. The time taken to raise this interrupt is dependant on the leaky bucket configuration of the activity monitors. The fastest leaky bucket setting will still take up to 128 ms to trigger the interrupt. The interrupt caused by the brief loss of the currently selected reference source is provided to facilitate very fast source failure detection if desired. It is triggered after missing just a couple of cycles of the reference source. Some applications require the facility to switch downstream devices based on the status of the reference sources. In order to provide extra flexibility, it is possible to flag the 'main reference failed' interrupt (addr 06, bit 6) on the pin TDO. This is simply a copy of the status bit in the interrupt register and is independent of the mask register settings. The bit is reset by writing to the interrupt status register in the normal way. This feature can be enabled and disabled by writing to bit 6 of register 48Hex.

Register Map

Shaded areas in the map are 'don't care' and writing either 0 or 1 will not affect any function of the device.

Bits labelled 'Set to 0' or 'Set to 1' must be set as stated during initialisation of the device, either following power up, or after a power on reset (POR). Failure to correctly set these bits may result in the device operating in an unexpected way.

Some registers do not appear in this list. These are either not used, or have test functionality. Do not write to any undefined registers as this may cause the device to operate in a test mode. If an undefined register has been inadvertently addressed, the device should be reset to ensure the undefined registers are at default values.

Table 11. Register Map

Addr. (Hex)	Parameter Name	Data Bit							
		7 (msb)	6	5	4	3	2	1	0 (lsb)
00	chip_id (read only)	Device part number (7:0)							
01		Device part number (15:8)							
02	chip_revision (read only)	Chip revision number (7:0)							
03	cnfg_control1 (read/write)			Multiple E1/T1 O/P	Analog div sync	Set to '0'	8k Edge Polarity	Set to '0'	Set to '0'
04	cnfg_control2 (read/write)			Phase loss flag limit			Set to '0'	Set to '1'	Set to '0'
05	sts_interrupts (read/write)	<I_8> valid change	<I_7> valid change	<I_6> valid change	<I_5> valid change	<I_4> valid change	<I_3> valid change	<I_2> valid change	<I_1> valid change
06		Operating mode	Main ref. failed	<I_14> valid change	<I_13> valid change	<I_12> valid change	<I_11> valid change	<I_10> valid change	<I_9> valid change
08	sts_T4_inputs (read/write)				T4 ref failed	Ami2 Violation	Ami2 L.O.S.	Ami1 Violation	Ami1 L.O.S.
09	sts_operating_mode (read only)						Operating mode (2:0)		
0A	sts_priority_table (read only)	Highest priority valid source				Currently selected reference source			
0B		3 rd highest priority valid source				2 nd highest priority valid source			
0C	sts_curr_inc_offset (read only)	Current increment offset (7:0)							
0D		Current increment offset (15:8)							
07								Current increment offset (18:16)	
0E	sts_sources_valid (read only)	<I_8>	<I_7>	<I_6>	<I_5>	<I_4>	<I_3>	<I_2>	<I_1>
0F				<I_14>	<I_13>	<I_12>	<I_11>	<I_10>	<I_9>

Table 11. Register Map (continued).

Addr. (Hex)	Parameter Name	Data Bit							
		7 (msb)	6	5	4	3	2	1	0 (lsb)
10	sts_reference_sources (read/write)	status <l_2>				status <l_1>			
11		status <l_4>				status <l_3>			
12		status <l_6>				status <l_5>			
13		status <l_8>				status <l_7>			
14		status <l_10>				status <l_9>			
15		status <l_12>				status <l_11>			
16		status <l_14>				status <l_13>			
18	cnfg_ref_selection_priority (read/write)	programmed_priority <l_2>				programmed_priority <l_1>			
19		programmed_priority <l_4>				programmed_priority <l_3>			
1A		programmed_priority <l_6>				programmed_priority <l_5>			
1B		programmed_priority <l_8>				programmed_priority <l_7>			
1C		programmed_priority <l_10>				programmed_priority <l_9>			
1D		programmed_priority <l_12>				programmed_priority <l_11>			
1E		programmed_priority <l_14>				programmed_priority <l_13>			
20	cnfg_ref_source_frequency (read/write)	divn	lock8k	bucket_id <l_1>(1:0)		reference_source_frequency <l_1>(3:0)			
21		divn	lock8k	bucket_id <l_2>(1:0)		reference_source_frequency <l_2>(3:0)			
22		divn	lock8k	bucket_id <l_3>(1:0)		reference_source_frequency <l_3>(3:0)			
23		divn	lock8k	bucket_id <l_4>(1:0)		reference_source_frequency <l_4>(3:0)			
24		divn	lock8k	bucket_id <l_5>(1:0)		reference_source_frequency <l_5>(3:0)			
25		divn	lock8k	bucket_id <l_6>(1:0)		reference_source_frequency <l_6>(3:0)			
26		divn	lock8k	bucket_id <l_7>(1:0)		reference_source_frequency <l_7>(3:0)			
27		divn	lock8k	bucket_id <l_8>(1:0)		reference_source_frequency <l_8>(3:0)			
28		divn	lock8k	bucket_id <l_9>(1:0)		reference_source_frequency <l_9>(3:0)			
29		divn	lock8k	bucket_id <l_10>(1:0)		reference_source_frequency <l_10>(3:0)			
2A		divn	lock8k	bucket_id <l_11>(1:0)		reference_source_frequency <l_11>(3:0)			
2B		divn	lock8k	bucket_id <l_12>(1:0)		reference_source_frequency <l_12>(3:0)			
2C		divn	lock8k	bucket_id <l_13>(1:0)		reference_source_frequency <l_13>(3:0)			
2D		divn	lock8k	bucket_id <l_14>(1:0)		reference_source_frequency <l_14>(3:0)			

Table 11. Register Map (continued).

Addr. (Hex)	Parameter Name	Data Bit							
		7 (msb)	6	5	4	3	2	1	0 (lsb)
30	cnfg_sts_remote_sources_valid (read/write)	Remote status, channels <8:1>							
31		Remote status, channels <14:9>							
32	cnfg_operating_mode (read/write)							Forced operating mode	
33	cnfg_ref_selection (read/write)						force_select_reference_source		
34	cnfg_mode (read/write)	Auto external 2K enable	Phase alarm timeout enable	Clock edge	Holdover Offset enable	External 2K Sync enable	SONET/SDH I/P	Master/Slave	Reversion mode
35	cnfg_T4 (read/write)			Squelch	Select T0/T1	Force T1 input source selection (only valid for inputs I_5 to I_10)			
36	cnfg_differential_inputs (read/write)							<I_6> PECL	<I_5> PECL
37	cnfg_uPsel_pins (read only)							Micro-processor type	
38	cnfg_T0_output_enable (read/write)	311.04MHz on T06	1=SONET 0=SDH for Dig2	1=SONET 0=SDH for Dig1	T01	T02	T03 19.44MHz	T04 38.88MHz	T05 77.76MHz
39	cnfg_T0_output_frequencies (read/write)	Digital2		Digital1		T02		T01	
3A	cnfg_differential_outputs (read/write)	T07 Frequency selection		T06 Frequency selection		T07 LVDS enable	T07 PECL enable	T06 LVDS enable	T06 PECL enable
3B	cnfg_bandwidth (read/write)	Auto b/w switch Acq/Lock	Acquisition bandwidth			Set to '0'	Normal/locked bandwidth		
3C	cnfg_nominal_frequency (read/write)	Nominal frequency (7:0)							
3D		Nominal frequency (15:8)							
3E	cnfg_holdover_offset (read/write)	Holdover offset (7:0)							
3F		Holdover offset (15:8)							
40		Auto Holdover Averaging					Holdover offset (18:16)		
41	cnfg_freq_limit (read/write)	DPLL Frequency offset limit (7:0)							
42								DPLL Frequency offset limit (9:8)	
43	cnfg_interrupt_mask (read/write)	<I_8> valid change	<I_7> valid change	<I_6> valid change	<I_5> valid change	<I_4> valid change	<I_3> valid change	<I_2> valid change	<I_1> valid change
44		Operating mode	Main ref. failed	<I_14> valid change	<I_13> valid change	<I_12> valid change	<I_11> valid change	<I_10> valid change	<I_9> valid change
45						T4 ref	Ami2 Violation	Ami2 L.O.S	Ami1 Violation
46	cnfg_freq_divn (read/write)	Divide-input-by-n ratio (7:0)							
47								Divide-input-by-n ratio (13:8)	

Table 11. Register Map (continued).

Addr. (Hex)	Parameter Name	Data Bit							
		7 (msb)	6	5	4	3	2	1	0 (lsb)
48	cnfg_monitors (read/write)		Flag ref lost on TDO	Ultra-fast switching	External source switch enable	Freeze phase buildout	Phase buildout enable	Frequency monitors configuration (1:0)	
50	cnfg_activ_upper_threshold0 (read/write)	Configuration 0: Activity alarm set threshold (7:0)							
51	cnfg_activ_lower_threshold0 (read/write)	Configuration 0: Activity alarm reset threshold (7:0)							
52	cnfg_bucket_size0 (read/write)	Configuration 0: Activity alarm bucket size (7:0)							
53	cnfg_decay_rate0 (read/write)							Cfg 0:decay_rate (1:0)	
54	cnfg_activ_upper_threshold1 (read/write)	Configuration 1: Activity alarm set threshold (7:0)							
55	cnfg_activ_lower_threshold1 (read/write)	Configuration 1: Activity alarm reset threshold (7:0)							
56	cnfg_bucket_size1 (read/write)	Configuration 1: Activity alarm bucket size (7:0)							
57	cnfg_decay_rate1 (read/write)							Cfg 1:decay_rate (1:0)	
58	cnfg_activ_upper_threshold2 (read/write)	Configuration 2: Activity alarm set threshold (7:0)							
59	cnfg_activ_lower_threshold2 (read/write)	Configuration 2: Activity alarm reset threshold (7:0)							
5A	cnfg_bucket_size2 (read/write)	Configuration 2: Activity alarm bucket size (7:0)							
5B	cnfg_decay_rate2 (read/write)							Cfg 2:decay_rate (1:0)	
5C	cnfg_activ_upper_threshold3 (read/write)	Configuration 3: Activity alarm set threshold (7:0)							
5D	cnfg_activ_lower_threshold3 (read/write)	Configuration 3: Activity alarm reset threshold (7:0)							
5E	cnfg_bucket_size3 (read/write)	Configuration 3: Activity alarm bucket size (7:0)							
5F	cnfg_decay_rate3 (read/write)							Cfg 3:decay_rate (1:0)	
7F	cnfg_uPsel (read/write)							Micro-processor type	

Register Map Description

Table 12. Register Map Description

Addr. (Hex)	Parameter Name	Description	Default Value (bin)
	chip_id	This register contains the chip ID = 8510 (decimal)	
00		Bits (7:0) Chip ID bits (7:0)	00111110
01		Bits (7:0) Chip ID bits (15:8)	00100001
02	chip_revision	This read only register contains the chip revision number This revision = 1 Last revision (engineering samples) = 0	00000001
03	cnfg_control1	Bits (7:6) Unused Bit 5 =1 32/24MHz to APLL: Feeds 2x Dig2 frequency to the APLL instead of the normal 77.76Mhz. Thus the normal OC3/STM1 outputs are replaced with multiple E1/T1 rates. Note: Dig2 set bits (Reg. 39h Bits (7:6)) must be set to 11 for this mode. =0 77.76MHz to APLL Bit 4 =1 Synchronizes the dividers in the output APLL section to the dividers in the DPLL section such that their phases align. This is necessary in order to have phase alignment between inputs and output clocks at OC3 derived rates (6.48 MHz to 77.76 MHz). Keeping this bit high may be necessary to avoid the dividers getting out of synchronization when quick changes in frequency occur such as a force into Free-Run. =0 The dividers may get out of phase following step changes in frequency, but in this mode the correct number of high frequency edges is guaranteed within any synchronization period. The output will frequency lock (default). The device will always remain in synchronization 2 seconds from a reset, before the default setting applies. Bits 3 Test control - leave unchanged, or set to '0' Bit 2 =1 When in 8k locking mode the system will lock to the rising input clock edge. =0 When in 8k locking mode the system will lock to the falling input clock edge. Bits (1:0) Test controls - leave unchanged, or set to '00'	XX000000
04	cnfg_control2	Bits (7:6) Unused Bits (5:3) define the phase loss flag limit. By default set to 4 (100) which corresponds to approximately 140°. A lower value sets a corresponding lower phase limit. The flag limit determines the value at which the DPLL indicates phase lost as a result of input jitter, a phase jump, or a frequency jump on the input Bits (2:0) Test controls - leave unchanged, or set to '010'	XX100010
	sts_interrupts	This register contains one bit for each bit of sts_sources_valid, one for loss of reference the device was locked to, and another for the operating mode. All bits are active high. All bits except the main_ref_failed bit (bit 14) are set on a 'change' in the state of the relevant status bit, i.e. if a source becomes valid, or goes invalid it will trigger an interrupt. If the Operating Mode (register 9) changes state the interrupt will be generated. Bit 14 (main_ref_failed) of the interrupt status register is used to flag inactivity on the reference that the device is locked to more quickly than the activity monitors can support. If bit 6 of the cnfg_monitors register (flag ref loss on TDO) is set, then the state of this bit is driven onto the TDO pin of the device. All bits are maskable by the bits in the cnfg_interrupt_mask register. Each bit may be cleared individually by writing a '1' to that bit, thus resetting the interrupt. Any number of bits can be cleared with a single write operation. Writing '0's will have no effect.	
05		Bits (7:0) <I_8> to <I_1>	00000000
06		Bits (7:0) Operating mode, main ref failed, <I_14> to <I_9>	00000000

Table 12. Register Map Description (continued).

Addr. (Hex)	Parameter Name	Description	Default Value (bin)
08	sts_T4_inputs	<p>This register holds the status flags of the AMI inputs and the TOUT4 reference. The alarms once set will hold their state until reset. Each bit may be cleared individually by writing a '1' to that bit, thus resetting the interrupt. Writing '0's will have no effect. These bits can also generate interrupts.</p> <p>Bits (7:5) Unused.</p> <p>Bit 4 =1 T4 reference failed - no valid T_{IN1} input (<L_10>:<L_5>), T4 DPLL cannot lock to source (default) =0 T4 reference good - valid T_{IN1} input available.</p> <p>Bit 3 =1 Ami2 Violation detected =0 Ami2 clear (default)</p> <p>Bit 2 =1 Ami2 Loss of signal =0 Ami2 clear (default)</p> <p>Bit 1 =1 Ami1 Violation detected =0 Ami1 clear (default)</p> <p>Bit 0 =1 Ami1 Loss of signal =0 Ami1 clear (default)</p>	XXX10000
09	sts_operating_mode	<p>This read-only register holds the current operating state of the main state machine. Figure 11 shows how the values of the 'operating state' variable match with the individual states.</p> <p>Bits (7:3) Unused.</p> <p>Bits (2:0) State 001 Free-Run (default) 010 Holdover 100 Locked 110 Pre-locked 101 Pre-locked2 111 Phase lost</p>	XXXXX001
0A	sts_priority_table	<p>This is a 16-bit read-only register.</p> <p>Bits (15:12) Third highest priority valid source: this is the channel number of the input reference source which is valid and has the next-highest priority to the second-highest-priority valid source.</p> <p>Bits (11:8) Second highest priority valid source: this is the channel number of the input reference source which is valid and has the next-highest priority to the highest-priority valid source.</p> <p>Bits (7:4) Highest priority valid source: this is the channel number of the input reference source which is valid and has the highest priority - it may not be the same as the currently selected reference source (due to failure history or changes in programmed priority).</p> <p>Bits (3:0) Currently selected reference source: this is the channel number of the input reference source which is currently input to DPLL.</p> <p>Note that these registers are updated by the state machine in response to the contents of the cnfg_ref_selection_priority register and the ongoing status of individual channels; channel number '0000', appearing in any of these registers, indicates that no channel is available for that priority.</p>	
0A		<p>Bits (7:4) Highest priority valid source (sts_priority_table bits (7:4)) Bits (3:0) Currently selected reference source (sts_priority_table bits (3:0))</p>	00000000
0B		<p>Bits (7:4) 3rd-highest priority valid source (sts_priority_table bits (15:12)) Bits (3:0) 2nd-highest priority valid source (sts_priority_table bits (11:8))</p>	00000000

Table 12. Register Map Description (continued).

Addr. (Hex)	Parameter Name	Description	Default Value (bin)
	sts_curr_inc_offset	This read-only register contains a signed-integer value representing the 19 significant bits of the current increment offset of the digital PLL. The register may be read periodically to build up a historical database for later use during holdover periods (this would only be necessary if an external oscillator which did not meet the stability criteria described in Local Oscillator Clock section is used). The register will read 00000000 immediately after reset.	
0C		Bits (7:0) sts_curr_inc_offset bits (7:0)	00000000
0D		Bits (7:0) sts_curr_inc_offset bits (15:8)	00000000
07		Bits (7:3) Unused Bits (2:0) sts_curr_inc_offset bits (18:16)	XXXXX000
	sts_sources_valid	This register contains a bit to show validity for every reference source. =1 Valid source =0 Invalid source (default)	
0E		Bits (7:0) <I_8> to <I_1>	00000000
0F		Bits (7:6) Unused Bits (5:0) <I_14> to <I_9>	XX000000
	sts_reference_sources	This is a 7-byte register which holds the status of each of the 14 input reference sources. The status of each reference source is shown in a 4-bit field. Each bit is active high. To aid status checking, a copy of each status bit 3 is provided in the sts_sources_valid register. The status is reported as follows: (Each bit may be cleared individually) Status bit 3 = Source valid (no alarms) (bit 3 is combination of bits (2:0)) (default 0) Status bit 2 = out-of-band alarm (default 1) Status bit 1 = no activity alarm (default 1) Status bit 0 = phase lock alarm (default 0)	
10		Bits (7:4) Status of input reference source <I_2> Bits (3:0) Status of input reference source <I_1>	01100110
11		Bits (7:4) Status of input reference source <I_4> Bits (3:0) Status of input reference source <I_3>	01100110
12		Bits (7:4) Status of input reference source <I_6> Bits (3:0) Status of input reference source <I_5>	01100110
13		Bits (7:4) Status of input reference source <I_8> Bits (3:0) Status of input reference source <I_7>	01100110
14		Bits (7:4) Status of input reference source <I_10> Bits (3:0) Status of input reference source <I_9>	01100110
15		Bits (7:4) Status of input reference source <I_12> Bits (3:0) Status of input reference source <I_11>	01100110
16	Bits (7:4) Status of input reference source <I_14> Bits (3:0) Status of input reference source <I_13>	01100110	
	cnfg_ref_selection_priority	This register holds the priority of each of the 14 input reference sources. The priority values are all relative to each other, with lower-valued numbers taking higher priorities. Only the values '1' to '15' (dec) are valid - '0' disables the reference source. Each reference source should be given a unique number, however two sources given the same priority number will be assigned on a first in first out basis. It is recommended to reserve the priority value '1' as this is used when forcing reference selection via the cnfg_ref_selection register. If the user does not intend to use the cnfg_ref_selection register then the priority value '1' need not be reserved.	
18		Bits (7:4) Programmed priority of input reference source <I_2> Bits (3:0) Programmed priority of input reference source <I_1>	00110010
19		Bits (7:4) Programmed priority of input reference source <I_4> Bits (3:0) Programmed priority of input reference source <I_3>	01010100
1A		Bits (7:4) Programmed priority of input reference source <I_6> Bits (3:0) Programmed priority of input reference source <I_5>	01110110
1B		Bits (7:4) Programmed priority of input reference source <I_8> Bits (3:0) Programmed priority of input reference source <I_7>	10011000

Table 12. Register Map Description (continued).

Addr. (Hex)	Parameter Name	Description	Default Value (bin)
1C	cnfg_ref_selection_priority (continued)	Bits (7:4) Programmed priority of input reference source <I_10>	10111010
		Bits (3:0) Programmed priority of input reference source <I_9>	
1D		Bits (7:4) Programmed priority of input reference source <I_12>	11010001 (MSTSLVB=0) 11011100 (MSTSLVB=1)
		Bits (3:0) Programmed priority of input reference source <I_11>	
1E		Bits (7:4) Programmed priority of input reference source <I_14>	11111110
		Bits (3:0) Programmed priority of input reference source <I_13>	
	cnfg_ref_source_frequency	<p>This register is used to set up each of the 14 input reference sources.</p> <p>Bits (7:6) of each byte defines the operation undertaken on the input frequency, in accordance with the following key:</p> <p>00 The input frequency is fed directly into the DPLL. (default). 01 The input frequency is internally divided down to 8 kHz, before being fed into the DPLL. (For high jitter tolerance). 10 Unsupported configuration - do not use. 11 Uses the division coefficient stored in registers 46 and 47 (cnfg_freq_divn) to divide the input by this value prior to being fed into the DPLL. The frequency monitors must be disabled. The divided down frequency should equal 8 kHz. The frequency (3:0) should be set to the nearest spot frequency just below the actual input frequency. The DivN feature works for input frequencies between 1.544 MHz and 100 MHz.</p> <p>Bits (5:4) define which leaky bucket group (0-3) is used, as defined in registers 50 to 5F. (default 00).</p> <p>Bits (3:0) defines the frequency of the reference source in accordance with the following:</p> <p>0000 8 kHz (fixed <I_1>, <I_2>, default <I_3>, <I_4>) 0001 1.544 MHz (SONET)/2.048 MHz (SDH) (as defined by register 34, bit 2) (default <I_12>, <I_13>, <I_14>) 0010 6.48 MHz (default <I_11> when MSTSLVB = 1) 0011 19.44 MHz (default <I_11> when MSTSLVB=0, and <I_5>, <I_6>, <I_7>, <I_8>, <I_9>, <I_10>) 0100 25.92 MHz 0101 38.88 MHz 0110 51.84 MHz 0111 77.76 MHz 1000 155.52 MHz 1001 2 kHz 1010 4 kHz</p>	
20		Frequency of reference source <I_1> - fixed at 00000000 for 8kHz only	00000000
21		Frequency of reference source <I_2> - fixed at 00000000 for 8kHz only	00000000
22		Frequency of reference source <I_3>	00000000
23		Frequency of reference source <I_4>	00000000
24		Frequency of reference source <I_5>	00000011
25		Frequency of reference source <I_6>	00000011
26		Frequency of reference source <I_7>	00000011
27		Frequency of reference source <I_8>	00000011
28		Frequency of reference source <I_9>	00000011
29		Frequency of reference source <I_10>	00000011
2A		Frequency of reference source <I_11>	00000010 (MSTSLVB=0) 00000011 (MSTSLVB=1)

Table 12. Register Map Description (continued).

Addr. (Hex)	Parameter Name	Description	Default Value (bin)
2B	cnfg_ref_source_frequency (continued)	Frequency of reference source <I_12>	00000001
2C		Frequency of reference source <I_13>	00000001
2D		Frequency of reference source <I_14>	00000001
	cnfg_sts_remote_sources_valid	This register holds the status of the reference sources supplied to the other device in a master/slave configuration. It is a copy of the other device's sts_sources_valid register. The register is part of the protection mechanism.	
30		Bits (7:0) Reference sources <I_8>:<I_1>	11111111
31		Bits (7:6) Unused Bits (5:0) Reference sources <I_14>:<I_9>	XX111111
32	cnfg_operating_mode	This register is used to force the device into a desired operating state, represented by the binary values shown in Figure 11. Value 0 (hex) allows the control state machine to operate automatically. Bits (7:3) Unused Bits (2:0) Desired operating state (as per Figure 11)	XXXXX000
33	cnfg_ref_selection	This register is used to force the device to select a particular input reference source, irrespective of its priority. Writing to this register temporarily raises the selected input to priority '1'. Provided no other input is already programmed with priority '1', and revertive mode is on, this source will be selected. Bits (7:4) Unused Bits (3:0) Desired reference source (0000 and 1111 disables the force selection, and allows automatic selection of all sources, default is 1111)	XXXX1111
34	cnfg_mode	This register contains several individual configuration fields, as detailed below: Bit 7 =1 Auto 2 kHz Sync enable: External 2 kHz Sync will be enabled only when the source is locked to 6.48 MHz. Otherwise it will be disabled (default) =0 Auto 2 kHz Sync disable: The user controls this function using bit 3 of this register, as described below Bit 6 =1 Phase Alarm Timeout enable: The phase alarm will timeout after 100 seconds (default) =0 Phase Alarm Timeout disable: The phase alarm will not timeout and must be reset by software Bit 5 =1 Rising Clock Edge selected: The device will reference to the rising edge of the external 12.8 MHz crystal oscillator signal =0 Falling edge Edge selected: The device will reference to the falling edge of the external 12.8 MHz crystal oscillator signal (default) Bit 4 =1 Holdover offset enable: The device will adopt the Holdover offset value stored in the cnfg_holdover_offset register, in order to set the frequency in Holdover =0 Holdover offset disable: The device will ignore the value and Holdover will freeze the frequency of the DPLL on entering Holdover mode (default) Bit 3 = 1 External 2 kHz Sync Enable: The device will align the phase of its internally generated Frame Sync signal (8 kHz) and Multi-Frame Sync signal (2 kHz) with that of the signal supplied to the Sync2K pin. The device should be locked to a 6.48 MHz output from another ACS8510. = 0 External 2 kHz Sync Disable: The device will ignore the Sync2k pin.	11001000 (MSTSLVB=0) (SONSDHB=0) 11001100 (MSTSLVB=0) (SONSDHB=1) 11000010 (MSTSLVB=1) (SONSDHB=0) 11000110 (MSTSLVB=1) (SONSDHB=1)

Table 12. Register Map Description (continued).

Addr. (Hex)	Parameter Name	Description	Default Value (bin)
34	cnfg_mode (continued)	<p>This register contains several individual configuration fields, as detailed below:</p> <p>Bit 2 = 1 SONET Mode: The device expects the input frequency of any input channel given the value '0001' in the cnfg_ref_source_frequency register to be 1544 kHz = 0 SDH Mode: The device expects the input frequency of any input channel given the value '0001' in the cnfg_ref_source_frequency register to be 2048 kHz. At start up or reset the bit value will be defaulted to the setting of pin SONSDHB. This setting can subsequently be altered by changing this bit value</p> <p>Bit 1 = 1 Master Mode: The device will adopt the master mode and make the active decisions of which source to select, etc. This bit is writeable, but its default value is determined by the pin, MSTSLVB = 0 Slave Mode: The device will adopt the slave mode and will follow the master device. At start up or reset the bit value will be defaulted to the setting of pin MSTSLVB. This setting can subsequently be altered by changing this bit value</p> <p>Bit 0 = 1 Revertive Mode: The device will switch to the highest priority source available shown in the sts_priority_table register, bits (7:4) = 0 Non Revertive Mode: The device will retain the presently selected source (default)</p>	<p>11001000 (MSTSLVB=0) (SONSDHB=0)</p> <p>11001100 (MSTSLVB=0) (SONSDHB=1)</p> <p>11000010 (MSTSLVB=1) (SONSDHB=0)</p> <p>11000110 (MSTSLVB=1) (SONSDHB=1)</p>
35	cnfg_T4	<p>This controls DPLL_T4 (output on TO8/TO9) and input source selection:</p> <p>Bits (7:6) Unused</p> <p>Bit 5 =1 DPLL_T4 is turned off (squelched) =0 DPLL_T4 is on (default)</p> <p>Bit 4 Selects which DPLL (T4 or T0) source feeds outputs TO8/TO9: =1 DPLL_T0 output is fed to outputs TO8 and TO9 =0 DPLL_T4 output is fed to outputs TO8 and TO9</p> <p>Bits (3:0) Input source selection. The device will switch to the source shown in this field for the generation of the T_{out4} signal. If '0' it will select the highest priority active T_{NI}.</p>	XX000000
36	cnfg_differential_inputs	<p>This register contains two individual configuration fields, as follows:</p> <p>Bits (7:2) Unused</p> <p>Bit 1 =1 Input <I_6> is PECL-compatible (Default) =0 Input <I_6> is LVDS-compatible</p> <p>Bit 0 =1 Input <I_5> is PECL-compatible =0 Input <I_5> is LVDS-compatible (Default)</p>	XXXXXX10
37	cnfg_uPsel_pins	<p>This read only register returns a value indicating the microprocessor type selected at power up or reset. This is set by the configuration of the UPSEL pins (pins 58 - 60). If the UPSEL pin configuration is changed while the device is operating no effect will take place, but this register will reflect that change, so indicating the configuration that will be implemented at the next power up or reset. The microprocessor type can be changed with the device operational, though register 7F.</p> <p>Bits (7:3) Unused.</p> <p>Bit (2:0) Microprocessor type 000 OFF (interface disabled) 001 EPROM 010 MULTIPLEXED 011 INTEL 100 MOTOROLA 101 SERIAL 110 OFF (interface disabled) 111 OFF (interface disabled)</p>	<p>Bits(7:3)=XXXXX Bits(2:0)=UPSEL pin configuration</p>

Table 12. Register Map Description (continued).

Addr. (Hex)	Parameter Name	Description	Default Value (bin)																				
38	cnfg_T0_output_enable	<p>This register contains several individual configuration fields, as follows:</p> <p>Bit 7 =1 T06 output frequency set to 311.04 MHz * =0 T06 output frequency set by Address 3A (5:4) (default)</p> <p>Bit 6 =1 SONET mode selected for Dig2 =0 SDH mode selected for Dig2 (default) - see register cnfg_T0_output_frequencies</p> <p>Bit 5 =1 SONET mode selected for Dig1 =0 SDH mode selected for Dig1 (default) - see register cnfg_T0_output_frequencies</p> <p>Bit 4 =1 Output port T01 enabled (default) =0 Output port T01 disabled** - see register cnfg_T0_output_frequencies</p> <p>Bit 3 =1 Output port T02 enabled (default) =0 Output port T02 disabled** - see register cnfg_T0_output_frequencies</p> <p>Bit 2 =1 Output port T03 enabled (19.44 MHz*) (default) =0 Output port T03 disabled**</p> <p>Bit 1 =1 Output port T04 enabled (38.88 MHz*) (default) =0 Output port T04 disabled**</p> <p>Bit 0 =1 Output port T05 enabled (77.76 MHz*) (default) =0 Output port T05 disabled**</p> <p>Notes: * Defaults frequencies are changed to multiples of E1/T1 if the appropriate bit of the <i>cnfg_control1</i> register is set to 1. For details, see Table 8. ** "Disabled" means that the output port holds a static logic value (the port is not Tri-stated).</p>	00011111																				
39	cnfg_T0_output_frequencies	<p>This register holds the frequency selections for each output port, as detailed below.*</p> <table border="0"> <tr> <td>Bits (7:6) Dig2</td> <td>Bits (5:4) Dig1</td> </tr> <tr> <td>00 1544 kHz/2048 kHz (default)</td> <td>00 1544 kHz/2048 kHz (default)</td> </tr> <tr> <td>01 3088 kHz/4096 kHz</td> <td>01 3088 kHz/4096 kHz</td> </tr> <tr> <td>10 6176 kHz/8192 kHz</td> <td>10 6176 kHz/8192 kHz</td> </tr> <tr> <td>11 12352 kHz/16384 kHz</td> <td>11 12352 kHz/16384 kHz</td> </tr> </table> <table border="0"> <tr> <td>Bits (3:2) T02</td> <td>Bits (1:0) T01</td> </tr> <tr> <td>00 25.92 MHz</td> <td>00 6.48 MHz (default)</td> </tr> <tr> <td>01 51.84 MHz</td> <td>01 25.92 MHz</td> </tr> <tr> <td>10 38.88 MHz (default)</td> <td>10 19.44 MHz</td> </tr> <tr> <td>11 Dig2</td> <td>11 Dig1</td> </tr> </table> <p>For Dig1/Dig2 the frequency values are shown for SONET/SDH. They are selected via the SONET/SDH bits in register <i>cnfg_T0_output_enable</i>.</p> <p>Note: * The above frequencies are changed to multiples of E1/T1 if the appropriate bit of the <i>cnfg_control1</i> register is set to 1. For details, see Table 8.</p>	Bits (7:6) Dig2	Bits (5:4) Dig1	00 1544 kHz/2048 kHz (default)	00 1544 kHz/2048 kHz (default)	01 3088 kHz/4096 kHz	01 3088 kHz/4096 kHz	10 6176 kHz/8192 kHz	10 6176 kHz/8192 kHz	11 12352 kHz/16384 kHz	11 12352 kHz/16384 kHz	Bits (3:2) T02	Bits (1:0) T01	00 25.92 MHz	00 6.48 MHz (default)	01 51.84 MHz	01 25.92 MHz	10 38.88 MHz (default)	10 19.44 MHz	11 Dig2	11 Dig1	00001000
Bits (7:6) Dig2	Bits (5:4) Dig1																						
00 1544 kHz/2048 kHz (default)	00 1544 kHz/2048 kHz (default)																						
01 3088 kHz/4096 kHz	01 3088 kHz/4096 kHz																						
10 6176 kHz/8192 kHz	10 6176 kHz/8192 kHz																						
11 12352 kHz/16384 kHz	11 12352 kHz/16384 kHz																						
Bits (3:2) T02	Bits (1:0) T01																						
00 25.92 MHz	00 6.48 MHz (default)																						
01 51.84 MHz	01 25.92 MHz																						
10 38.88 MHz (default)	10 19.44 MHz																						
11 Dig2	11 Dig1																						

Table 12. Register Map Description (continued).

Addr. (Hex)	Parameter Name	Description	Default Value (bin)																																								
3A	cnfg_differential_outputs	<p>This register holds the frequency selections and the port-technology type for the differential outputs, T06 and T07, as detailed below.</p> <table border="0"> <tr> <td>Bits (7:6)</td> <td>T07</td> <td>Bits (5:4)</td> <td>T06</td> </tr> <tr> <td>00</td> <td>155.52 MHz</td> <td>00</td> <td>38.88 MHz (default)</td> </tr> <tr> <td>01</td> <td>51.84 MHz</td> <td>01</td> <td>19.44 MHz</td> </tr> <tr> <td>10</td> <td>77.76 MHz</td> <td>10</td> <td>155.52 MHz</td> </tr> <tr> <td>11</td> <td>19.44 MHz (default)</td> <td>11</td> <td>Dig1</td> </tr> </table> <table border="0"> <tr> <td>Bits (3:2)</td> <td>T07</td> <td>(1:0)</td> <td>T06</td> </tr> <tr> <td>00</td> <td>Port disabled</td> <td>00</td> <td>Port disabled</td> </tr> <tr> <td>01</td> <td>PECL-compatible (default)</td> <td>01</td> <td>PECL-compatible</td> </tr> <tr> <td>10</td> <td>LVDS-compatible</td> <td>10</td> <td>LVDS-compatible (default)</td> </tr> <tr> <td>11</td> <td>Unused</td> <td>11</td> <td>Unused</td> </tr> </table>	Bits (7:6)	T07	Bits (5:4)	T06	00	155.52 MHz	00	38.88 MHz (default)	01	51.84 MHz	01	19.44 MHz	10	77.76 MHz	10	155.52 MHz	11	19.44 MHz (default)	11	Dig1	Bits (3:2)	T07	(1:0)	T06	00	Port disabled	00	Port disabled	01	PECL-compatible (default)	01	PECL-compatible	10	LVDS-compatible	10	LVDS-compatible (default)	11	Unused	11	Unused	11000110
Bits (7:6)	T07	Bits (5:4)	T06																																								
00	155.52 MHz	00	38.88 MHz (default)																																								
01	51.84 MHz	01	19.44 MHz																																								
10	77.76 MHz	10	155.52 MHz																																								
11	19.44 MHz (default)	11	Dig1																																								
Bits (3:2)	T07	(1:0)	T06																																								
00	Port disabled	00	Port disabled																																								
01	PECL-compatible (default)	01	PECL-compatible																																								
10	LVDS-compatible	10	LVDS-compatible (default)																																								
11	Unused	11	Unused																																								
3B	cnfg_bandwidth	<p>This register contains information used to control the operation of the digital PLL. When bandwidth selection is set to automatic, the DPLL will use the acquisition bandwidth setting when out of lock, and the normal/locked bandwidth setting when in lock. When set to manual, the DPLL will always use the normal/locked bandwidth setting.</p> <p>Bit 7 =1 Automatic operation =0 Manual operation (default)</p> <table border="0"> <tr> <td>Bits (6:4)</td> <td>Acquisition bandwidth</td> <td>Bit (2:0)</td> <td>Loop bandwidth</td> </tr> <tr> <td>000</td> <td>0.1 Hz</td> <td>000</td> <td>0.1 Hz</td> </tr> <tr> <td>001</td> <td>0.3 Hz</td> <td>001</td> <td>0.3 Hz</td> </tr> <tr> <td>010</td> <td>0.5Hz</td> <td>010</td> <td>0.5 Hz</td> </tr> <tr> <td>011</td> <td>1.0 Hz</td> <td>011</td> <td>1.0 Hz</td> </tr> <tr> <td>100</td> <td>2.0 Hz</td> <td>100</td> <td>2.0 Hz</td> </tr> <tr> <td>101</td> <td>4.0 Hz</td> <td>101</td> <td>4.0 Hz (default)</td> </tr> <tr> <td>110</td> <td>8.0 Hz</td> <td>110</td> <td>8.0 Hz</td> </tr> <tr> <td>111</td> <td>17 Hz (default)</td> <td>111</td> <td>17 Hz</td> </tr> </table> <p>Bit 3 Unused</p>	Bits (6:4)	Acquisition bandwidth	Bit (2:0)	Loop bandwidth	000	0.1 Hz	000	0.1 Hz	001	0.3 Hz	001	0.3 Hz	010	0.5Hz	010	0.5 Hz	011	1.0 Hz	011	1.0 Hz	100	2.0 Hz	100	2.0 Hz	101	4.0 Hz	101	4.0 Hz (default)	110	8.0 Hz	110	8.0 Hz	111	17 Hz (default)	111	17 Hz	0111X101				
Bits (6:4)	Acquisition bandwidth	Bit (2:0)	Loop bandwidth																																								
000	0.1 Hz	000	0.1 Hz																																								
001	0.3 Hz	001	0.3 Hz																																								
010	0.5Hz	010	0.5 Hz																																								
011	1.0 Hz	011	1.0 Hz																																								
100	2.0 Hz	100	2.0 Hz																																								
101	4.0 Hz	101	4.0 Hz (default)																																								
110	8.0 Hz	110	8.0 Hz																																								
111	17 Hz (default)	111	17 Hz																																								
3C	cnfg_nominal_frequency	This register holds a 16 bit unsigned integer allowing compensation for offset of the crystal oscillator from the nominal 12.8 MHz. See section Crystal Frequency Calibration. Default results in 0 ppm adjustment.																																									
3D		Bits (7:0) cnfg_nominal_frequency bits (7:0)	10011001																																								
3E	cnfg_holdover_offset	Bits (7:0) cnfg_nominal_frequency bits (15:8)	10011001																																								
3F		This register holds a 19 bit signed integer, representing the holdover offset value, which can be used to set the holdover mode frequency when enabled via the holdover offset enabled bit in the cnfg_mode register.																																									
40	cnfg_holdover_offset	Bits (7:0) cnfg_holdover_offset bits (7:0)	00000000																																								
		Bits (7:0) cnfg_holdover_offset bits (15:8)	00000000																																								
	cnfg_holdover_offset	Bit 7 =1 Auto Holdover Averaging enable. This enables the frequency average to be taken from 32 samples. One sample taken every 32 seconds, after the frequency has been confirmed to be in-band by the frequency monitors. This gives a 17 minute history of the currently locked to reference source for use in Holdover. (default). =0 Auto Holdover Averaging disabled.	1XXXX000																																								
		Bits (6:3) Unused																																									
	cnfg_freq_limit	Bits (2:0) cnfg_holdover_offset bits (18:16)																																									
		<p>This register holds a 10 bit unsigned integer representing the pull-in range of the DPLL. It should be set according to the accuracy of crystal implemented in the application, using the following formula:</p> $\text{Frequency range +/- (ppm)} = (\text{cnfg_freq_limit} \times 0.0785) + 0.01647 \text{ or}$ $\text{cnfg_freq_limit} = (\text{Frequency range +/- (ppm)} - 0.01647) / 0.0785$ <p>Default value when SRCSW is left unconnected or tied low is ± 9.3 ppm. Default value when SRCSW is high is the full range of around ± 80 ppm.</p>																																									

Table 12. Register Map Description (continued).

Addr. (Hex)	Parameter Name	Description	Default Value (bin)
41	cnfg_freq_limit (continued)	Bits (7:0) cnfg_freq_limit bits (7:0)	01110101 (SRCSW low) 11111111 (SRCSW high)
42		Bits (7:2) Unused Bits (1:0) cnfg_freq_limit bits (9:8)	XXXXXX00 (SRCSW low) XXXXXX11 (SRCSW high)
	cnfg_interrupt-mask	Each bit, if set to '0' will disable the appropriate interrupt source in either the interrupt status register or the sts_T4_inputs register.	
43		Bits (7:0) cnfg_interrupt_mask bits (7:0)	11111111
44		Bits (7:0) cnfg_interrupt_mask bits (15:8)	11111111
45		Bits (7:5) Unused Bits (4:0) cnfg_interrupt_mask bits (20:16)	XXX11111
	cnfg_freq_divn	This 14 bit integer is used as the divisor for any input applied to <L_14>:<L_1> to get the phase locking frequency desired. Only active for inputs with the DivN bit set to '1'. This will cause the input frequency to be divided by (N+1) prior to phase comparison, e.g. program N to: $((\text{input freq}) / 8 \text{ kHz}) - 1$	
		The reference_source_frequency bits should be set to reflect the closest spot frequency to the input frequency, but must be lower than the input frequency.	
46		Bits (7:0) cnfg_freq_divn bits (7:0)	00000000
47	Bits (7:6) Unused Bits (5:0) cnfg_freq_divn bits (13:8)	XX000000	
48	cnfg_monitors	This 7 bit register allows global configuration of monitors and control of phase build out. Bit 7 Unused Bit 6 =1 Enables value of the main_ref_failed interrupt to be driven out of pin TDO =0 Disables value of the main_ref_failed interrupt from being driven out of pin TDO (default) Bit 5 =1 Enables ultra fast switching: Allows the DPLL to raise an inactivity alarm on the currently selected source after missing only a few cycles. See section on Ultra Fast Switching =0 Normal operation (default) Bit 4 =1 Forces locking to <L_3> if pin SRCSW high, or <L_4> if SRCSW low =0 Pin SRCSW ignored, and automatic control enabled Bit 3 =1 Will freeze the output phase relationship with the current input to output phase offset =0 Allows changes in input to output phase offset (Normal phase build out mode) (default) Bit 2 =1 Enables phase build out (default) =0 DPLL will always lock to 0° Bits (1:0) are for configuring frequency monitors- 00 = off, 01 = 15 ppm (default), others are reserved for future use.	X0000101 (SRCSW low) X0010101 (SRCSW high)
50	cnfg_activ_upper_threshold0	Bits (7:0) set the value in the leaky bucket that causes the activity alarm to be raised	00000110
51	cnfg_activ_lower_threshold0	Bits (7:0) set the value in the leaky bucket that causes the activity alarm to be cleared	00000100
52	cnfg_bucket_size0	Bits (7:0) set the maximum value that the leaky bucket can reach given an inactive input	00001000
53	cnfg_decay_rate0	Bits (7:2) Unused Bits (1:0) control the leak rate of the leaky bucket. The fill-rate of the bucket is +1 for every 128 ms interval that has experienced some level of inactivity. The decay rate is programmable in ratios of the fill rate. The ratio can be set to 1:1, 2:1, 4:1, 8:1 by using values of 00, 01, 10, 11 respectively. However, these buckets are not 'true' leaky buckets in nature. The bucket stops 'leaking' when it is being filled. This means that the fill and decay rates can be the same (00 = 1:1) with the net effect that an active input can be recognised at the same rate as an inactive one.	XXXXXX01

Table 12. Register Map Description (continued).

Addr. (Hex)	Parameter Name	Description	Default Value (bin)
54	cnfg_activ_upper_threshold1	As for register 50 but for bucket 1	00000110
55	cnfg_activ_lower_threshold1	As for register 51 but for bucket 1	00000100
56	cnfg_bucket_size1	As for register 52 but for bucket 1	00001000
57	cnfg_decay_rate1	As for register 53 but for bucket 1	XXXXXX01
58	cnfg_activ_upper_threshold2	As for register 50 but for bucket 2	00000110
59	cnfg_activ_lower_threshold2	As for register 51 but for bucket 2	00000100
5A	cnfg_bucket_size2	As for register 52 but for bucket 2	00001000
5B	cnfg_decay_rate2	As for register 53 but for bucket 2	XXXXXX01
5C	cnfg_activ_upper_threshold3	As for register 50 but for bucket 3	00000110
5D	cnfg_activ_lower_threshold3	As for register 51 but for bucket 3	00000100
5E	cnfg_bucket_size3	As for register 52 but for bucket 3	00001000
5F	cnfg_decay_rate3	As for register 53 but for bucket 3	XXXXXX01
7F	cnfg_uPsel	Bits (7:3) Unused Bits (2:0) can be used to change the mode of the microprocessor interface. The interface will initially be set as the pins UPSEL (pins 58 - 60) - the pin set up can be read via register 37 (cnfg_uPsel_pins). At power up or reset the device will default to this setting. This register can be used to change the microprocessor mode after start up, supporting booting from EPROM and subsequently communicating via another mode. At start up the EPROM will download the pre-programmed settings for all the registers, and as the last operation, action the change of interface with this last register. It is recommended that this function is only used for EPROM start up applications, as subsequent versions of this device may only allow operation in this way. The bits are defined in Table 9 or as given in register 37 of the register map description.	Bits(7:3)= XXXXX Bits(2:0)= Pin dependent

Selection of Input Reference Clock Source

Under normal operation, the input reference sources are selected automatically by an order of priority. But, for special circumstances, such as chip or board testing, the selection may be forced by configuration.

Automatic operation selects a reference source based on its pre-defined priority and its current availability. A table is maintained which lists all reference sources in the order of priority. This is initially downloaded into the ACS8510 via the microprocessor interface by the Network Manager, and is subsequently modified by the results of the ongoing quality monitoring. In this way, when all the defined sources are active and valid, the source with the highest programmed priority is selected but, if this source fails, the next-highest source is selected, and so on.

Restoration of repaired reference sources is handled carefully to avoid inadvertent disturbance of the output clock. The ACS8510 has two modes of operation; Revertive and

Non-Revertive. In Revertive mode, if a re-validated (or newly validated) source has a higher priority than the reference source which is currently selected, a switch over will take place. Many applications prefer to minimise the clock switching events and choose Non-Revertive mode. In Non-Revertive mode, when a re-validated (or newly validated) source has a higher priority than the selected source will be maintained. The re-validation of the reference source will be flagged in the sts_sources_valid register and, if not masked, will generate an interrupt. Selection of the re-validated source can only take place under software control - the software should briefly enable Revertive mode to affect a switch-over to the higher priority source. If the selected source fails under these conditions the device will indicate that it is still locked to the failed reference. It will not select the higher priority source until instructed to do so by the software; by briefly setting the Revertive mode bit. When there is a reference available with higher priority than the selected reference, there will be NO change of reference source as long as the Non-Revertive mode remains on AND the device will remain indicating

a locked state on the failed reference. This is the case even if there are lower priority references available or the currently selected reference fails. When the ONLY valid reference sources that are available have a lower priority than the selected reference, a failure of the selected reference will always trigger a switch-over, regardless of whether Revertive or Non-Revertive mode has been chosen.

Also, in a Master/Slave redundancy-protection scheme, the Slave device(s) must follow the Master device. The alignment of the Master and Slave devices is part of the protection mechanism. The availability of each source is determined by a combination of local and remote monitoring of each source. Each input reference source supplied to each ACS8510 device is monitored locally and the results are made available to other devices.

Forced Control Selection

A configuration register, *cnfg_ref_selection*, controls both the choice of automatic or forced selection and the selection itself (when forced selection is required). The forced selection of an input reference source occurs when the *cnfg_ref_selection* variable contains a non-zero value, the value then representing the input port required to be selected. This is not the normal mode of operation, and the *cnfg_ref_selection* variable is defaulted to the all-one value on reset, thereby adopting the automatic selection of the reference source.

Automatic Control Selection

When an automatic selection is required, the *cnfg_ref_selection* register must be set to all zero or all one. The configuration registers, *cnfg_ref_selection_priority*, held in the μ P port block, consists of seven, 8 bit registers organised as one 4 bit register per input reference port. Each register holds a 4-bit value which represents the desired priority of that particular port. Unused ports should be given the value, '0000' or '1111', in the relevant register to indicate they are not to be included

in the priority table. On power-up, or following a reset, the whole of the configuration file will be defaulted to the values defined by Table 4. The selection priority values are all relative to each other, with lower-valued numbers taking higher priorities. Each reference source should be given a unique number, the valid values are 1 to 15 (dec). A value of 0 disables the reference source. However if two or more inputs are given the same priority number those inputs will be selected on a first in, first out basis. If the first of two same priority number sources goes invalid the second will be switched in. If the first then becomes valid again, it becomes the second source on the first in, first out basis, and there will not be a switch. If a third source with the same priority number as the other two becomes valid, it joins the priority list on the same first in, first out basis. There is no implied priority based on the channel numbers.

The input port <I_11> is for the connection of the synchronous clock of the T_{OUTO} output of the Master device (or the active-Slave device), to be used to align the T_{OUTO} output with the Master (or active-Slave) device if this device is acting in a subordinate-Slave or subordinate-Master role.

Ultra Fast Switching

A reference source is normally disqualified after the leaky bucket monitor thresholds have been crossed. An option for a faster disqualification has been implemented, whereby if register 48H, bit 5 (Ultra Fast Switching), is set then a loss of activity of just a few reference clock cycles will set the 'no activity alarm' and cause a reference switch. This can be chosen to cause an interrupt to occur instead of or as well as causing the reference switch. The *sts_interrupts* register 05 Hex Bit 14 (main_ref_failed) of the interrupt status register is used to flag inactivity on the reference that the device is locked to much faster than the activity monitors can support. If bit 6 of the *cnfg_monitors* register (flag ref loss on TDO) is set, then the state of this bit is driven onto the TDO pin of the device.

The flagging of the loss of the main reference failure on TDO is simply allowing the status of the *sts_interrupt* bit 14 to be reflected in the state of the TDO output pin. The pin will, therefore remain High until the interrupt is cleared. This functionality is not enabled by default so the usual JTAG functions can be used. When JTAG is normally used straight out of power-up, then this feature will have no bearing on the functionality. The TDO flagging feature will need to be disabled if JTAG is not enabled on power-up and the feature has since been enabled.

When the TDO output from the ACS8510 is connected to the TDI pin of the next device in the JTAG scan chain, the implementation should be such that a logic change caused by the action of the interrupt on the TDI input should not effect the operation when JTAG is not active.

External Protection Switching

Fast external switching between inputs <I_3> and <I_4> can also be triggered directly from a dedicated pin (SRCSW). This mode can be activated either by holding this pin high during reset, or by writing to bit 4 of register address 48Hex. Once external protection switching is

enabled, then the value of this pin directly selects either <I_3> (SRCSW high) or <I_4> (SRCSW low). If this mode is activated at reset by pulling the SRCSW pin high, then it configures the default frequency tolerance of <I_3> and <I_4> to +/- 80 ppm (register address 41Hex and 42Hex). Any of these registers can be subsequently set by external software if required.

When external protection switching is enabled, the device will operate as a simple switch. All clock monitoring is disabled and the DPLL will simply be forced to try to lock on to the indicated reference source.

Clock Quality Monitoring

Clock quality is monitored and used to modify the priority tables of the local and remote ACS8510 devices. The following parameters are monitored:

1. Activity (toggling)
2. Frequency (This monitoring is only performed when there is no irregular operation of the clock or loss of clock condition)

In addition, input ports <I_1> and <I_2> carry AMI-encoded composite clocks which are

Figure 9. Inactivity and Irregularity Monitoring

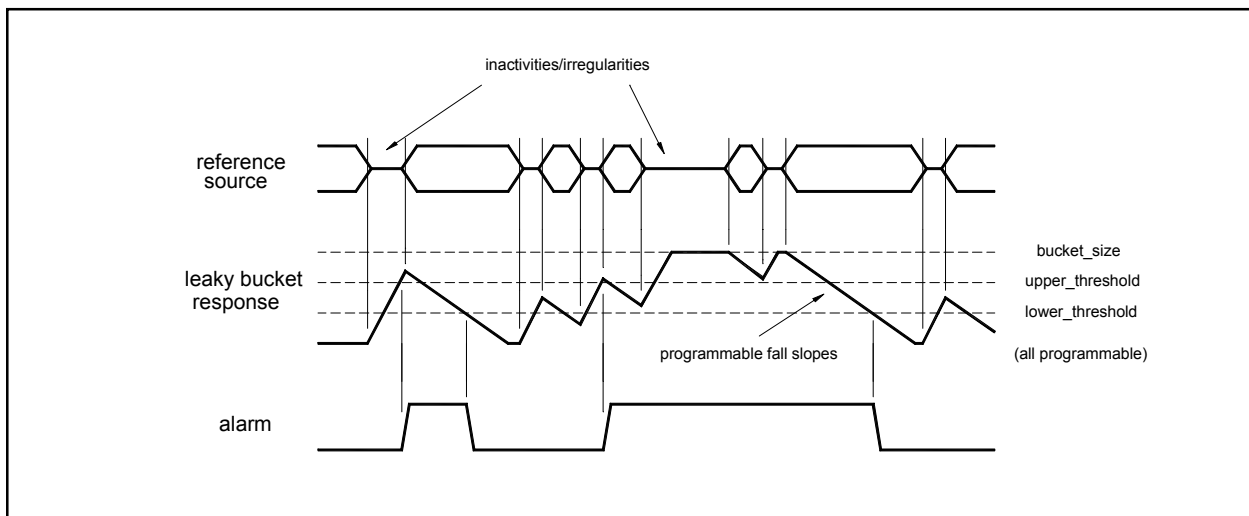

monitored by the AMI-decoder blocks. Loss of signal is declared by the decoders when either the signal amplitude falls below +0.3 V or there is no activity for 1 ms.

Any reference source which suffers a loss-of-signal, loss-of-activity, loss-of-regularity or clock-out-of-band condition will be declared as unavailable.

Clock quality monitoring is a continuous process which is used to identify clock problems. There is a difference in dynamics between the selected clock and the other reference clocks. Anomalies occurring on non-selected reference sources affect only that source's suitability for selection, whereas anomalies occurring on the selected clock could have a detrimental impact on the accuracy of the output clock.

Anomalies, whether affecting signal purity or signal frequency, could induce jitter or frequency offsets in the output clock, leading to anomalous behaviour. Anomalies on the selected clock, therefore, have to be detected

as they occur and the phase locked loop must be temporarily isolated until the clock is once again pure. The clock monitoring process cannot be used for this because the high degree of accuracy required dictates that the process be slow. To achieve the immediacy required by the phase locked loop requires an alternative mechanism. The phase locked loop itself contains appropriate circuitry, based around the phase detector, and isolates itself from the selected reference source as soon as a signal impurity is detected. It can likewise respond to frequency offsets outside the permitted range since these result in saturation of the phase detector. When the phase locked loop is isolated from the reference source, it is essentially operating in a Holdover state; this is preferable to feeding the loop with a standby source, either temporarily or permanently, since excessive phase excursions on the output clock are avoided.

Anomalies detected by the phase detector are integrated in a leaky bucket accumulator.

Leaky bucket timing

The time taken to raise an inactivity alarm on a reference source that has previously been fully active (leaky bucket empty) will be:

$$\frac{(cnfg_activ_upper_threshold \ N)}{8} \quad \text{secs}$$

where N is the number of the relevant leaky bucket configuration. If an input is intermittently inactive then this time can be longer. The default setting of *cnfg_activ_upper_threshold* is 6, therefore the default time is 0.75 s.

The time taken to cancel the activity alarm on a previously completely inactive reference source is calculated as:

$$\frac{2^{(cnfg_decay_rate \ N)} \times ((cnfg_bucket_size \ N) - (cnfg_activ_lower_thrshold \ N))}{8} \quad \text{secs}$$

where N is the number of the relevant leaky bucket configuration in each case. The default settings are shown in the following:

$$\frac{2^1 \times (8-4)}{8} = 1.0 \text{ s}$$

Occasional anomalies do not cause the accumulator to cross the alarm setting threshold, so the selected reference source is retained. Persistent anomalies cause the alarm setting threshold to be crossed and result in the selected reference source being rejected.

Activity Monitoring

The ACS8510 has a combined inactivity and irregularity monitor. The ACS8510 uses a 'leaky bucket' accumulator, which is a digital circuit which mimics the operation of an analog integrator, in which input pulses increase the output amplitude but die away over time. Such integrators are used when alarms have to be triggered either by fairly regular defect events, which occur sufficiently close together, or by defect events which occur in bursts. Events which are sufficiently spread out should not trigger the alarm. By adjusting the alarm setting threshold, the point at which the alarm is triggered can be controlled. The point at which the alarm is cleared depends upon the decay rate and the alarm clearing threshold. On the alarm setting side, if several events occur close together, each event adds to the amplitude and the alarm will be triggered quickly; if events occur a little more spread out, but still sufficiently close together to overcome the decay, the alarm will be triggered eventually. If events occur at a rate which is not sufficient to overcome the decay, the alarm will not be triggered. On the alarm clearing side, if no defect events occur for a sufficient time, the amplitude will decay gradually and the alarm will be cleared when the amplitude falls below the alarm clearing threshold. The ability to decay the amplitude over time allows the importance of defect events to be reduced as time passes by. This means that, in the case of isolated events, the alarm will not be set, whereas, once the alarm becomes set, it will be held on until normal operation has persisted for a suitable time (but if the operation is still erratic, the alarm will remain set). See Figure 9.

The 'leaky bucket' accumulators are programmable for size, alarm set & reset thresholds and decay rate. Each source is monitored over a 128 ms period. If, within a 128 ms period, an irregularity occurs that is not deemed to be due to allowable jitter/wander, then the accumulator is incremented. The accumulator will continue to increment up to the point that it reaches the programmed bucket size. The 'fill rate' of the leaky bucket is, therefore, 8 units/second. The 'leak rate' of the leaky bucket is programmable to be in multiples of the fill rate (x1, x0.5, x0.25 and x0.125) to give a programmable leak rate from 8 units/sec down to 1 unit/sec. A conflict between trying to 'leak' at the same time as a 'fill' is avoided by preventing a 'leak' when a 'fill' event occurs.

Disqualification of a non-selected reference source is based on inactivity, or on an out of band result from the frequency monitors. The currently selected reference source can be disqualified for phase, frequency, inactivity or if the source is outside the DPLL lock range. If the currently selected reference source is disqualified, the next highest priority, active reference source is selected.

Frequency Monitoring

The ACS8510 performs frequency monitoring to identify reference sources which have drifted outside the acceptable frequency range of +/- 16.6 ppm (measured with respect to the output clock). The *sts_reference_sources* out-of-band alarm for a particular reference source is raised when the reference source is outside the acceptable frequency range. The ACS8510 DPLL has a programmable frequency limit of +/- 80 ppm. If the range is programmed to be > 16.6 ppm, the frequency monitors should be disabled so the input reference source is not automatically rejected as out of frequency range.

Modes of Operation

The ACS8510 has three primary modes of operation (Free-run, Locked and Holdover) supported by three secondary, temporary modes (Pre-Locked, Lost_Phase and Pre-Locked2). These are shown in the State Transition Diagram, Figure 11.

The ACS8510 can operate in Forced or Automatic control. On reset, the ACS8510 reverts to Automatic Control, where transitions between states are controlled completely automatically. Forced Control can be invoked by configuration, allowing transitions to be performed under external control. This is not the normal mode of operation, but is provided for special occasions such as testing, or where a high degree of hands-on control is required.

Free-run mode

The Free-run mode is typically used following a power-on-reset or a device reset before network synchronization has been achieved. In the Free-run mode, the timing and synchronization signals generated from the ACS8510 are based on the Master clock frequency provided from the external oscillator and are not synchronized to an input reference source. The frequency of the output clock is a fixed multiple of the frequency of the external oscillator, and the accuracy of the output clock is equal to the accuracy of the Master clock.

The transition from Free-run to Pre-locked occurs when the ACS8510 selects a reference source.

Pre-Locked mode

The ACS8510 will enter the Locked state in a maximum of 100 seconds, as defined by GR-1244-CORE specification, if the selected reference source is of good quality. If the device cannot achieve lock within 100 seconds, it reverts to Free-run mode and another reference source is selected.

Locked mode

The Locked mode is used when an input reference source has been selected and the PLL has had time to lock. When the Locked mode is achieved, the output signal is in phase and locked to the selected input reference source. The selected input reference source is determined by the priority table. When the ACS8510 is in Locked mode, the output frequency and phase follows that of the selected input reference source. Variations of the external crystal frequency have a minimal effect on the output frequency. Only the minimum to maximum frequency range is affected. Note that the term, 'in phase', is not applied in the conventional sense when the ACS8510 is used as a frequency translator (e.g., when the input frequency is 2.048 MHz and the output frequency is 19.44 MHz) as the input and output cycles will be constantly moving past each other; however, this variation will itself be cyclical over time unless the input and output are not locked.

Lost_Phase mode

Lost-phase mode is entered when the current phase error, as measured within the DPLL, is larger than a preset limit (see register 04, bits 5:3), as a result of a frequency or phase transient on the selected reference source.

This mode is similar in behavior to the Pre-locked or Pre-locked(2) modes, although in this mode the DPLL is attempting to regain lock to the same reference rather than attempt lock to a new reference.

If the DPLL cannot regain lock within 100 s, the source is disqualified, and one of the following transitions takes place:

1. Go to Pre-Locked(2);
 - If a known-good standby source is available.
2. Go to Holdover;
 - If no standby sources are available.

Holdover mode

The Holdover mode is used when the ACS8510 has been in Locked mode for long enough to acquire stable frequency data, but the final selected reference source has become unavailable and a replacement has not yet been qualified for selection.

In Holdover mode, the ACS8510 provides the timing and synchronisation signals to maintain the Network Element (NE), but they are not phase locked to any input reference source. The timing is based on a stored value of the frequency ratio obtained during the last Locked mode period.

To allow for further development of the way the internal algorithm operates, and to allow for customised switching behaviour, the switch to and from Holdover state may be controlled by external software.

The device must be set in either 'manual' mode or 'automatic' mode:

1. Register *cnfg_mode* bit 'holdover offset en' set high (manual mode).

The Holdover frequency is determined by the value in register *cnfg_holdover_offset*. This is a 19 bit signed number, with a LSB resolution of 0.0003 ppm, which gives an adjustment range of ± 80 ppm. This value can be derived from a reading of the register *sts_curr_inc_offset* (addr 0D, 0C and 07) which gives, in the same format, an indication of the current output frequency deviation, which would be read when the device is locked. If required, this value could be read by an external microcontroller and averaged over the time required. The averaged value could then be fed to the *cnfg_holdover_offset* register ready for setting of the averaged frequency value when the device enters Holdover mode. The *sts_curr_inc_offset* value is internally derived from the Digital Phase Locked Loop (DPLL) integral path value, which already represents a well averaged measure of the current frequency, depending on the loop bandwidth selected.

2. Register *cnfg_mode* bit 'holdover offset en' set low (automatic mode).

In automatic control, the device can be run in one of two ways:

- 2.1 Register *cnfg_holdover_offset* register 40 bit 7 'auto holdover averaging' is set high. The value is averaged

internally over 32 samples at 32 seconds apart, giving the average frequency over approximately the last 20 minutes. The proportional DPLL path is ignored so that recent signal disturbances do not affect the Holdover frequency value. If the device has been previously correctly locked, missing pulses in the input clock stream fed to the SETS IC are ignored, hence also avoiding any frequency disturbances to the output frequency value when an input clock source fails.

- 2.2 Register *cnfg_holdover_offset* register 40 bit 7 'auto holdover averaging' is set low. This simply freezes the DPLL at the current frequency (as reported by the *sts_curr_inc_offset* register). The proportional DPLL path is ignored so that recent signal disturbances do not affect the Holdover frequency value.

Automatic control with internal averaging (option 2.1) is the default condition.

If the TCXO frequency is varying due to temperature fluctuations in the room, then the instantaneous value can be different from the average value, and then it may be possible to exceed the 0.05 ppm limit (depending on how extreme the temperature fluctuations are). It is advantageous to shield the TCXO to slow down frequency changes due to drift and external temperature fluctuations.

The frequency accuracy of Holdover mode has to meet the ITU-T, ETSI and Telcordia performance requirements. The performance of the external oscillator clock is critical in this mode, although only the frequency stability is important - the stability of the output clock in Holdover is directly related to the stability of the external oscillator.

Pre-Locked(2) mode

This state is very similar to the Pre-Locked state. It is entered from the Holdover state when a reference source has been selected and applied to the phase locked loop. It is also entered if the device is operating in Revertive mode and a higher-priority reference source is restored.

Upon applying a reference source to the phase locked loop, the ACS8510 will enter the Locked state in a maximum of 100 seconds, as defined

by GR-1244-CORE specification, if the selected reference source is of good quality.

If the device cannot achieve lock within 100 seconds, it reverts to Holdover mode and another reference source is selected.

Protection Facility

The ACS8510 supports redundancy protection. The primary functions of this include:

- Alignment of the priority tables of both Master and Slave ACS8510 devices so as to align the selection of reference sources of both Master and Slave ACS8510 devices.
- Alignment of the phases of the 8 kHz and 2 kHz clocks in both Master and Slave ACS8510 devices to within one cycle of the 77.76 MHz internal clock.

When two ACS8510 devices are to be used in a redundancy-protection scheme within an NE, one will be designated as the Master and the other as the Slave. It is expected that an NE will use the T_{OUT0} output for its internal operations because the T_{OUT4} output is intended to feed an SSU/BITS system. An SSU/BITS will not be bothered by phase differences between signals arriving from different sources because it typically incorporates line build-out functions to absorb phase differences on reference inputs. This means that the phasing of the composite clocks between two ACS8510 devices do not have to be mutually-aligned. The same is not true, however, of the T_{OUT0} output signals (T_{01} - T_{07} , Frame clock and Multi-Frame clock). It is usually important to align the phases of all equivalent T_{OUT0} signals generated by different sources so that switch-over from one device to another does not affect the internal operations of the NE. Both ACS8510 devices will produce the same signals, which will be routed around the NE to the various consumers (clock sinks). With the possible exception of a

through-timing mode, the signals from the Master device will be used by all consumers, unless the Master device fails, when each consumer will switch over to the signals generated by the Slave device.

Switchover to a new T_{OUT0} clock should be as hitless as possible. This requires the signals of both ACS8510 devices to be phase aligned at each consumer. Phase alignment requires frequency alignment. To ensure that both devices can generate output clocks locked to the same source, both devices are supplied with the same reference sources on the same input ports and will have identical priority tables. Failures of selected reference sources will result in both ACS8510 devices making the same updates to their priority tables as availability information will be updated in both devices. Although, in principle, the priority tables will be the same if the same reference sources are used on the same input port on each device, in practice, this is only true if the reference sources actually arrive at each device - failures of a source seen only by one device and not by the other, such as could be caused, for example, by a backplane connector failure, would result in the priority tables becoming misaligned. It is thus necessary to force the priority tables to be aligned under normal operating conditions so that the devices can make the same decisions - this can be achieved by loading the availability seen by one device (via the *sts_reference_sources* register) into the *cnfg_sts_remote_sources_valid* register of the other device. Another factor which could affect hit-less switching is the frequency of the local oscillator clock used by each ACS8510 device: these clocks are not mutually aligned and, whilst this has no impact on the frequency of the output clocks during locked mode, it could cause the output frequencies to diverge during Holdover mode if no action were taken to avoid it. In order to maintain alignment of the output frequencies of each ACS8510 device even

during Holdover, the Master device's 6.48 MHz output is fed into the Slave device on its <I_11> pin, whilst the Multi-Frame Sync (2 kHz) output is fed to the Sync2k input of the Slave. In this way, the Slave locks to the master's output and remains locked whilst the Master moves between operating states. Only when the Master fails does the Slave use its own reference inputs - should the Master have been in the Holdover state, the Slave device will see the same lack of reference sources and also enter the Holdover state. This scheme also provides a convenient way to phase-align all T_{OUTO} output clocks in Master and Slave devices, and also to detect the failure of the Master device.

If a Master device fails, the Slave has to take over responsibility for the generation of the output clocks, including the 8 kHz and 2 kHz Frame and Multi-Frame clocks. The Slave device is also given responsibility for building the priority table and performing the reference switching operations. The Slave device, therefore, adopts a more active role when the Master has failed. The *cnfg_mode* register 34 (Hex) Bit 1 contains the 'Master/Slave' control bit to determine the designation of the device.

To restore redundancy protection, the Master has to be repaired and replaced. When this occurs, the new Master cannot immediately adopt its normal role because it must not cause phase hits on the output clocks. It has, therefore, to adopt a subordinate role to the active Slave device, at least until such time as it has acquired alignment to the 8 kHz and 2 kHz frame and Multi-Frame clocks and the priority table of the Slave device; then, when a switch-back (restoration) is ordered, the Master can take over responsibility. These activities, in Master or Slave operation, are summarized in Table 12 and described in detail in Application Note AN-SETS-2.

Alignment of Priority Tables in Master and Slave ACS8510

Correct protection will only be achieved by connecting individual reference sources to the same input ports on each device and priority tables in each device must be aligned to each other.

The Master device must take account of the availability of each reference source seen by another device and a Slave device must adopt the same order of priority as the Master device (except that the Slave's highest-priority input is <I_11>). Both devices monitor the reference sources and decide the availability of each source; if the failure of a reference source is seen by both devices, they will both update their priority tables - however, if the reference source failure is only seen by one device and not by both, the priority tables could get out of step: this could be catastrophic if it resulted in two devices choosing different reference sources since any slight differences in frequency variation over time (e.g. wander) would mis-align the phase of the 8 kHz Frame and 2 kHz Multi-Frame clocks produced by the individual devices, resulting in phase hits on switch-over. It is therefore important that the same priority table be built by each device, using the reference source availability seen by each device.

The monitoring of the reference sources performed by a Master ACS8510 results in a list of available sources being placed in a *sts_valid_sources* register. This information is used within the device as one of the masks used to build the device's priority table. The information is passed to the Slave device and used to configure the *cnfg_sts_remote_sources_valid* register so that it can use it as a mask in building its own priority tables. The information is passed between devices using the microprocessor port.

Alignment of the Selection of Reference Sources for T_{OUT4} Generation in the Master and Slave ACS8510

As stated previously, there is no need to align the phases of the T_{OUT4} outputs in Master and Slave devices. There is a need, however, to ensure that all devices select the same reference source. But, since there is no Holdover mode required for the generation of the T_{OUT4} clock, and every reference source is continuously monitored within each device, it is permissible to rely on external intelligence to command a switch-over to an alternative source should the selected one fail. The time delay involved in detecting the failure, indicating it to the outside and selecting a new source, will result only in the SSU/BITS entering its Holdover mode for a short time.

Alignment of the Phases of the 8kHz and 2kHz Clocks in both Master and Slave ACS8510

In addition to aligning the edges of the T_{OUT0} outputs of Master and Slave devices, it is necessary to align the edges of the Frame and Multi-Frame clocks. If this is not performed, frame alignment may be lost in distant equipment on switch-over to an alternative device, resulting in anomalous network operation of a very serious nature.

In accordance with the alignment mechanism used with the main T_{OUT0} clock (described in the opening paragraphs of this section), whereby the 6.48 MHz output of the Master device is supplied to the Slave device, the alignment of both the 8 kHz and 2 kHz clocks is accomplished (they are already synchronous to the T_{OUT0} clocks) by feeding the 2 kHz clock of the Master device into the Slave device. The Multi-Frame Sync clock output of the Slave device is also fed to the Sync2K input of the Master device. Alignment of the Multi-Frame Sync input occurs only when *cnfg_mode* register, bit 3, address 34Hex External 2 kHz Sync Enable is set to 1.

JTAG

The JTAG connections on the ACS8510 allow a full boundary scan to be made. The JTAG implementation is fully compliant to IEEE 1149.1, with the following minor exceptions, and the user should refer to the standard for further information.

1. The output boundary scan cells do not capture data from the core, and so do not support EXTEST. However this does not affect board testing.
2. In common with some other manufacturers, pin TRST is internally pulled low to disable JTAG by default. The standard is to pull high. The polarity of TRST is as the standard: TRST high to enable JTAG boundary scan mode, TRST low for normal operation.
3. The device does not support the optional tri-state capability (HIGHZ). This will be supported on the next revision of the device.

The JTAG timing diagram is shown in Figure 17.

PORB

The Power On Reset (PORB) pin resets the device if forced Low for a power on reset to be initiated. The reset is asynchronous, the minimum Low pulse width is 5 ns. Reset is needed to initialize all of the register values to their defaults. Asserting Reset is required at power on, and may be re-asserted at any time to restore defaults. This is implemented most simplistically by an external capacitor to GND along with the internal pull-up resistor. The ACS8510 is held in a reset state for 250 ms after the PORB pin has been pulled High. In normal operation PORB should be held High.

Figure 10. Master-Slave Schematic

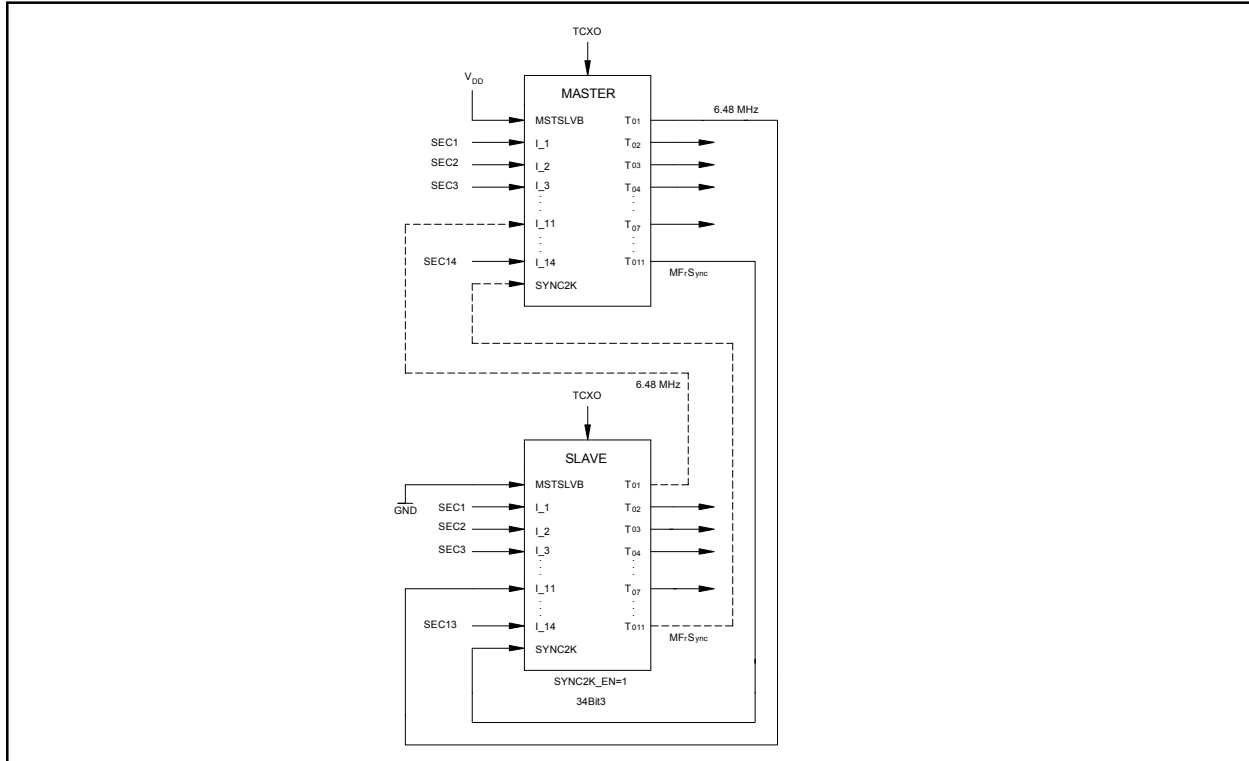

Table 13. Master-Slave Relationship

Ref_sources to Master ACS8510	Ref_sources to Slave ACS8510	Master ACS8510 status	Slave ACS8510 status	Master ACS8510	Slave ACS8510 output	Comments
All good	All good	Good	Good	Locked (ref_x)	Locked to master	Note 1
Some failed	Some others failed	Good	Good	Locked (ref_y)	Locked to master	Note 1
Good	Good	Good	Failed	Locked (ref_x)	Dead	
Good	Good	Failed	Good	Dead	Locked (ref_x)	Note 2
Good	Good	Failed	Failed	Dead	Dead	
Failed	Failed	Failed	Good	Holdover	Locked to master	Note 3
Failed	Failed	Good	Failed	Holdover	Dead	
Failed	Failed	Failed	Good	Dead	Holdover	
Failed	Failed	Failed	Failed	Dead	Dead	

Notes to Table 13

Note 1: Both ACS8510 must build a common priority table so that the Slave ACS8510 can select the same input reference source as the Master ACS8510 if the Master fails (when the Master is OK, the Slave locks to the Master's output).

Note 2: Slave ACS8510 uses common priority table, built before Master ACS8510 failed - priority table can be modified as status of the input reference sources changes

Note 3: Slave ACS8510 outputs must remain in phase with those of Master ACS8510

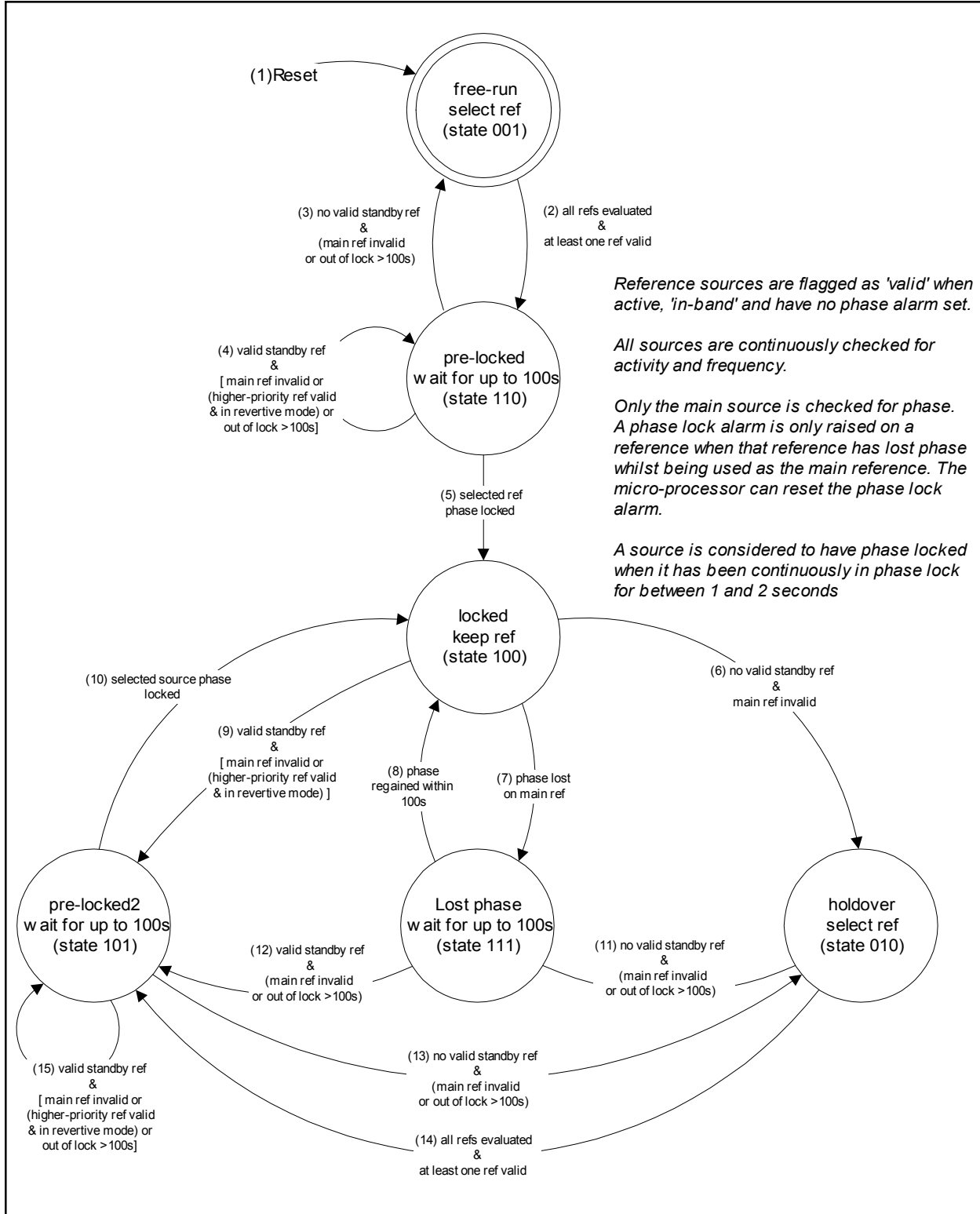
Figure 11. Automatic Mode Control State Diagram

Electrical Specification

Important Note: The 'Absolute Maximum Ratings' are stress ratings only, and functional operation of the device at conditions other than those indicated in the 'Operating Conditions' sections of this specification are not implied. Exposure to the absolute maximum ratings for an extended period may reduce the reliability or useful lifetime of the product.

Table 14. Absolute Maximum Ratings

PARAMETER	SYMBOL	MIN	MAX	UNITS
Supply Voltage $V_{DD}, V_{D+}, V_{A1+}, V_{A2+}$	V_{DD}	-0.5	3.6	V
Input Voltage (non-supply pins)	V_{in}	-	5.5	V
Output Voltage (non-supply pins)	V_{out}	-	5.5	V
Ambient Operating Temperature Range	T_A	-40	+85	°C
Storage Temperature	T_{stor}	-50	+150	°C

Table 15. Operating Conditions

PARAMETER	SYMBOL	MIN	TYP	MAX	UNITS
Power Supply (dc voltage) $V_{DD}, V_{D+}, V_{A1+}, V_{A2+}, V_{AMI+}, V_{DD_DIFF}$	VDD	3.0	3.3	3.6	V
Power Supply (dc voltage) VDD5	VDD5	3.0	3.3/5.0	5.5	V
Ambient temperature Range	T_A	-40	-	+85	°C
Supply current (Typical - one 19 MHz output)	I_{DD}	-	110	200	mA
Total power dissipation	P_{TOT}	-	360	720	mW

Table 16. DC Characteristics: TTL Input Port

Across all operating conditions, unless otherwise stated

PARAMETER	SYMBOL	MIN	TYP	MAX	UNITS
V_{in} High	V_{ih}	2.0	-	-	V
V_{in} Low	V_{il}	-	-	0.8	V
Input current	I_{in}	-	-	10	μA

Table 17. DC Characteristics: TTL Input Port with Internal Pull-up

Across all operating conditions, unless otherwise stated

PARAMETER	SYMBOL	MIN	TYP	MAX	UNITS
V_{in} High	V_{ih}	2.0	-	-	V
V_{in} Low	V_{il}	-	-	0.8	V
Pull-up resistor	PU	30	-	80	k Ω
Input current	I_{in}	-	-	120	μ A

Table 18. DC Characteristics: TTL Input Port with Internal Pull-down

Across all operating conditions, unless otherwise stated

PARAMETER	SYMBOL	MIN	TYP	MAX	UNITS
V_{in} High	V_{ih}	2.0	-	-	V
V_{in} Low	V_{il}	-	-	0.8	V
Pull-down resistor	PD	30	-	80	k Ω
Input current	I_{in}	-	-	120	μ A

Table 19. DC Characteristics: TTL Output Port

Across all operating conditions, unless otherwise stated

PARAMETER	SYMBOL	MIN	TYP	MAX	UNITS
V_{out} Low $I_{ol} = 4\text{mA}$	V_{ol}	0	-	0.4	V
V_{out} High $I_{oh} = 4\text{mA}$	V_{oh}	2.4	-	-	V
Drive current	ID	-	-	4	mA

Table 20. DC Characteristics: PECL Input/Output Port

Across all operating conditions, unless otherwise stated

PARAMETER	SYMBOL	MIN	TYP	MAX	UNITS
PECL Input Low voltage Differential inputs (Note 1)	V_{ILPECL}	VDD-2.5	-	VDD-0.5	V
PECL Input High voltage Differential inputs (Note 1)	V_{IHPECL}	VDD-2.4	-	VDD-0.4	V
Input Differential voltage	V_{IDPECL}	0.1	-	1.4	V
PECL Input Low voltage Single ended input (Note 2)	V_{ILPECL_S}	VDD-2.4	-	VDD-1.5	V
PECL Input High voltage Single ended input (Note 2)	V_{IHPECL_S}	VDD-1.3	-	VDD-0.5	V
Input High current Input differential voltage $V_{ID} = 1.4v$	I_{IHPECL}	-10	-	+10	μA
Input Low current Input differential voltage $V_{ID} = 1.4v$	I_{ILPECL}	-10	-	+10	μA
PECL Output Low voltage (Note 3)	V_{OLPECL}	VDD-2.10	-	VDD-1.62	V
PECL Output High voltage (Note 3)	V_{OHPECL}	VDD-1.25	-	VDD-0.88	V
PECL Output Differential voltage (Note 1)	V_{ODPECL}	580	-	900	mV

Notes to Table 20

Unused differential input ports should be left floating and set in LVDS mode, or the positive and negative inputs tied to VDD and GND respectively.

Note 1. Assuming a differential input voltage of at least 100 mV.

Note 2. Unused differential input terminated to VDD-1.4 V.

Note 3. With 50 Ω load on each pin to VDD-2 V. i.e. 82 Ω to GND and 130 Ω to VDD.

Figure 12. Recommended Line Termination for PECL Input/Output Ports

Table 21. DC Characteristics: LVDS Input/Output Port

Across all operating conditions, unless otherwise stated

PARAMETER	SYMBOL	MIN	TYP	MAX	UNITS
LVDS Input voltage range Differential input voltage = 100 mV	V_{VRLVDS}	0	-	2.40	V
LVDS Differential input threshold	V_{DITH}	-100	-	+100	mV
LVDS Input Differential voltage	V_{IDLVDS}	0.1	-	1.4	V
LVDS Input termination resistance Must be placed externally across the LVDS+/- input pins of ACS8510. Resistor should be 100Ω with 5% tolerance	R_{TERM}	95	100	105	Ω
LVDS Output high voltage (Note 1)	V_{OHLVDS}	-	-	1.585	V
LVDS Output low voltage (Note 1)	V_{OLLVDS}	0.885	-	-	V
LVDS Differential output voltage (Note 1)	V_{ODLVDS}	250	-	450	mV
LVDS Change in magnitude of differential output voltage for complimentary states (Note 1)	$V_{DOSLVDS}$	-	-	25	mV
LVDS output offset voltage Temperature = 25°C (Note 1)	V_{OSLVDS}	1.125	-	1.275	V

Note to Table 21

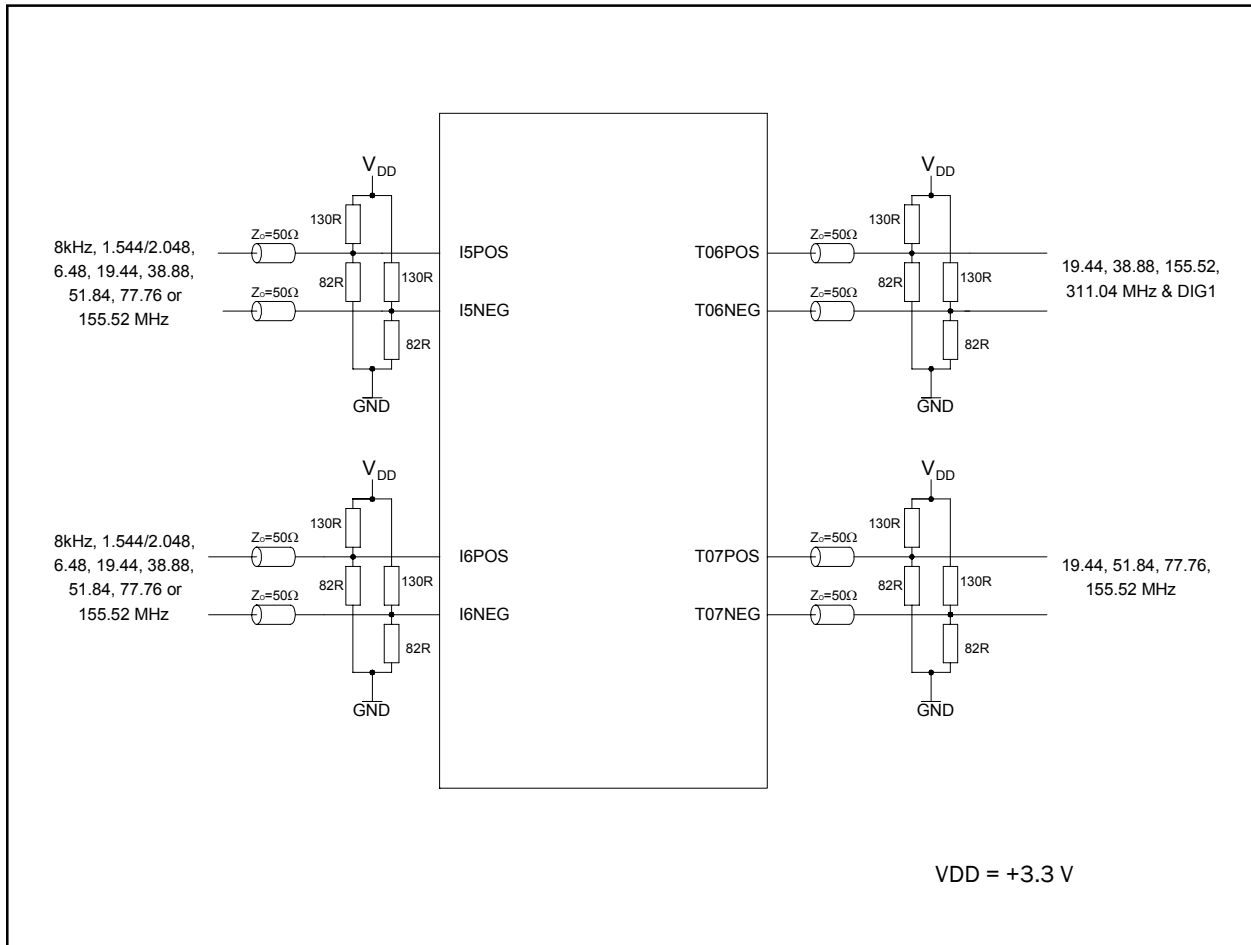
Note 1. With 100 Ω load between the differential outputs.

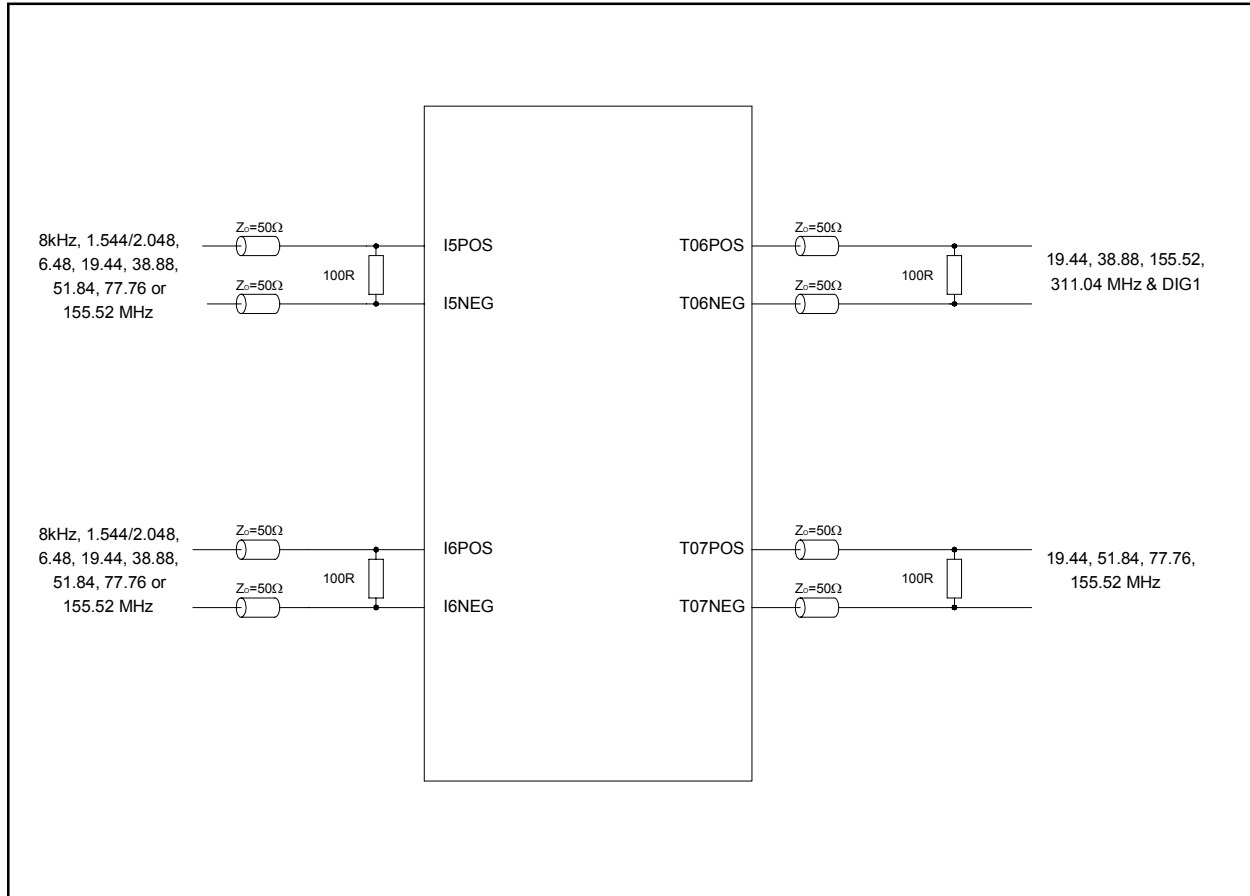
Figure 13. Recommended Line Termination for LVDS Input/Output Ports

DC Characteristics: AMI Input/Output Port

Across all operating conditions, unless otherwise stated

The Alternate Mark Inversion (AMI) signal is DC balanced and consists of positive and negative pulses with a peak to peak voltage of 2.0 +/- 0.2 V.

The electrical specifications are taken from option a) of Table 2/G.703 - Digital 64 kbit/s centralized clock interface, from ITU G.703.

Table 22. DC Characteristics: AMI Input/Output Port

PARAMETER	SYMBOL	MIN	TYP	MAX	UNITS
Input Pulse width	t_{PW}	1.56	7.8	14.04	us
Input Pulse rise/fall time	$t_{R/F}$	-	-	5	us
AMI Input voltage high	$V_{IH\ AMI}$	2.5	-	$V_{DD} + 0.3$	V
AMI Input voltage middle	$V_{VIM\ AMI}$	1.5	1.65	1.8	V
AMI Input voltage low	$V_{VIL\ AMI}$	0	-	1.4	V
AMI Output current drive	I_{AMIOUT}	-	-	20	mA
AMI Output high voltage Output current = 20mA	$V_{OH\ AMI}$	$V_{DD} - 0.16$	-	-	V
AMI Output low voltage Output current = 20mA	V_{OLAMI}	-	-	0.16	V
Nominal test load impedance	R_{TEST}	-	110	-	Ω
"Mark" amplitude after transformer	V_{MARK}	0.9	1.0	1.1	V
"Space" amplitude after transformer	V_{SPACE}	-0.1	0	0.1	V

The electrical characteristics of 64 kbits/s interface are as follows;

Nominal bit rate: 64 kbit/s. The tolerance is determined by the network clock stability.

There should be a symmetrical pair carrying the composite timing signal (64 kHz and 8 kHz). The use of transformers is recommended.

Over-voltage protection requirement; refer to Recommendation K.41.

Code conversion rules;

The data signals are coded in AMI code with 100% duty cycle. The composite clock timing signals convey the 64 kHz bit-timing information using AMI coding with a 50% to 70% duty ratio and the 8 kHz octet phase information by introducing violations in the code rule. The structure of the signals and voltage levels are shown in Figures 14 and 15.

Figure 14. Signal Structure of 64 kHz/8kHz Central Clock Interface

after suitable input/output transformer (also see Figure 6/G.703)

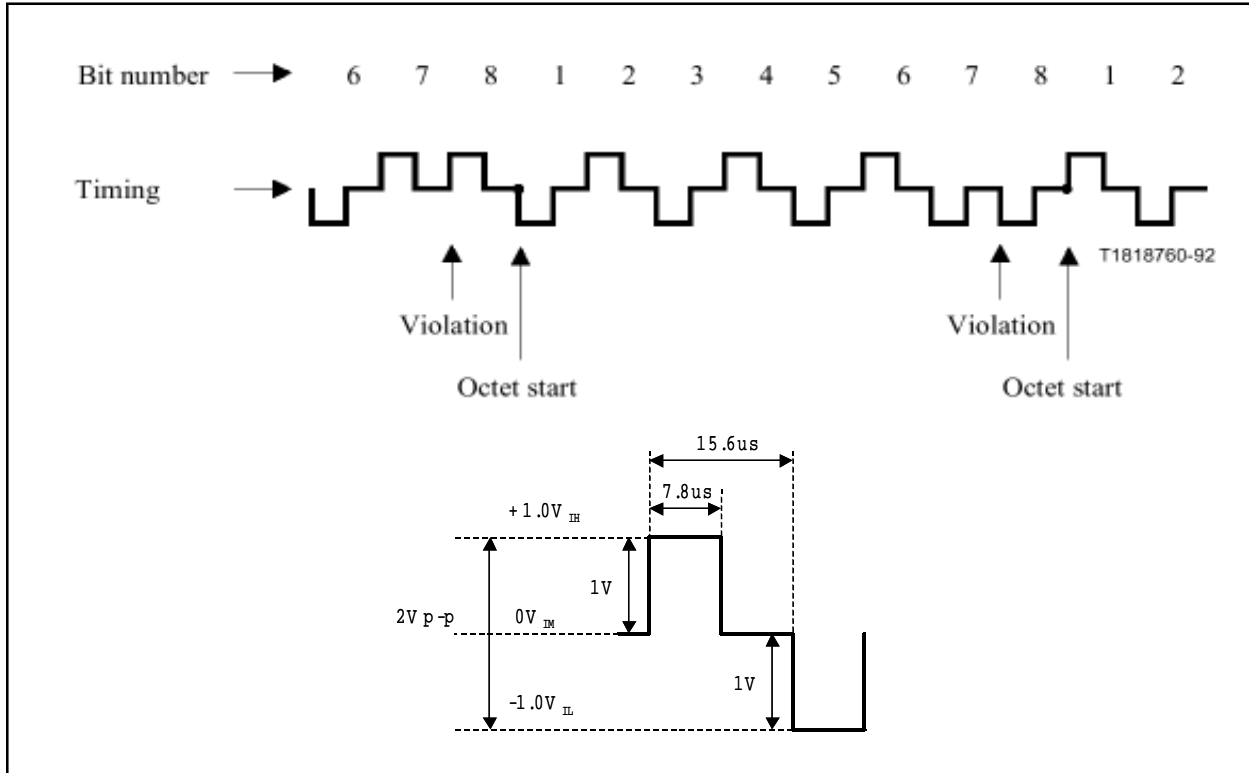
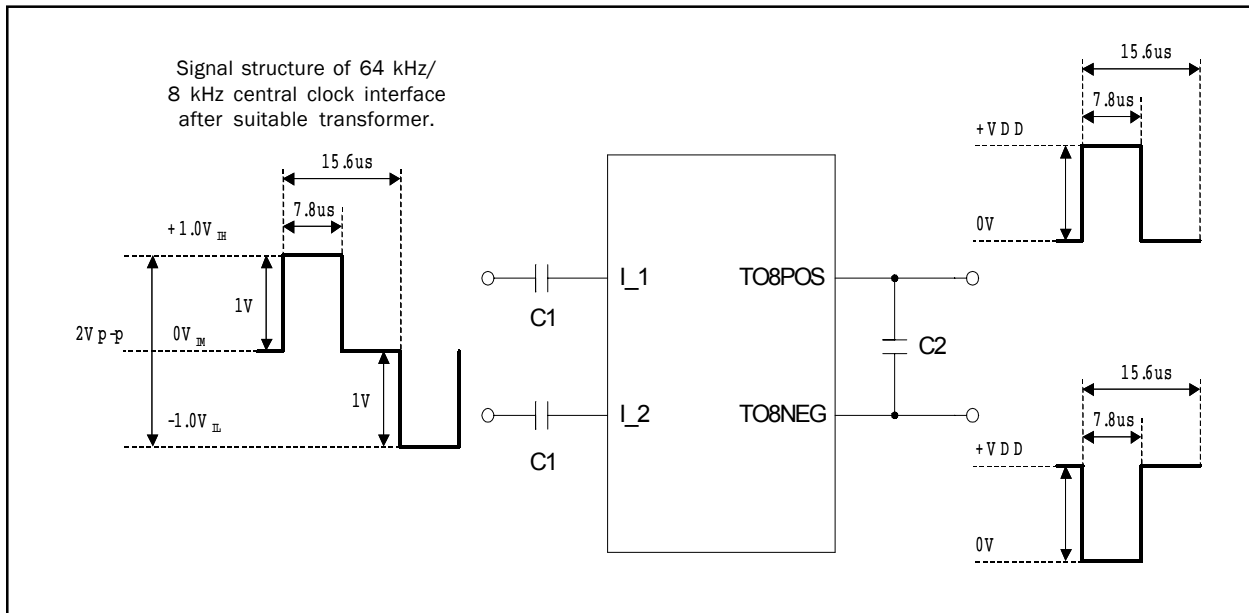

Figure 15. AMI Input and Output Signal Levels

Figure 16. Recommended Line Termination for AMI Output/Output Ports

Table 23. DC Characteristics: Output Jitter Generation (Test Definition G.813)

Across all operating conditions, unless otherwise stated

Output jitter generation measured over 60 seconds interval, UI pp max measured using Vectron 6664 12.8 MHz TCXO on ICT Flexacom + 10 MHz reference from Wavetek 905.

Test definition	Filter used	UI spec	UI measurement on ACS8510 Rev 2
G.813 for 155.52 MHz option 1	500 Hz to 1.3 MHz	UI _{pp} = 0.5	0.058 (Note 2)
G.813 for 155.52 MHz option 1	65 kHz to 1.3 MHz	UI _{pp} = 0.1	0.048 (Note 3) 0.048 (Note 2)
G.813 for 155.52 MHz option 2	12 kHz to 1.3 MHz	UI _{pp} = 0.1	0.053 (Note 4) 0.053 (Note 5)
			0.058 (Note 6) 0.053 (Note 7)
			0.053 (Note 2) 0.058 (Note 3)
			0.057 (Note 8) 0.055 (Note 9)
			0.057 (Note 10) 0.057 (Note 11)
			0.057 (Note 12) 0.053 (Note 13)
G.813 & G.812 for 2.048 MHz option 1	20 Hz to 100 kHz	UI _{pp} = 0.05	0.046 (Note 14)

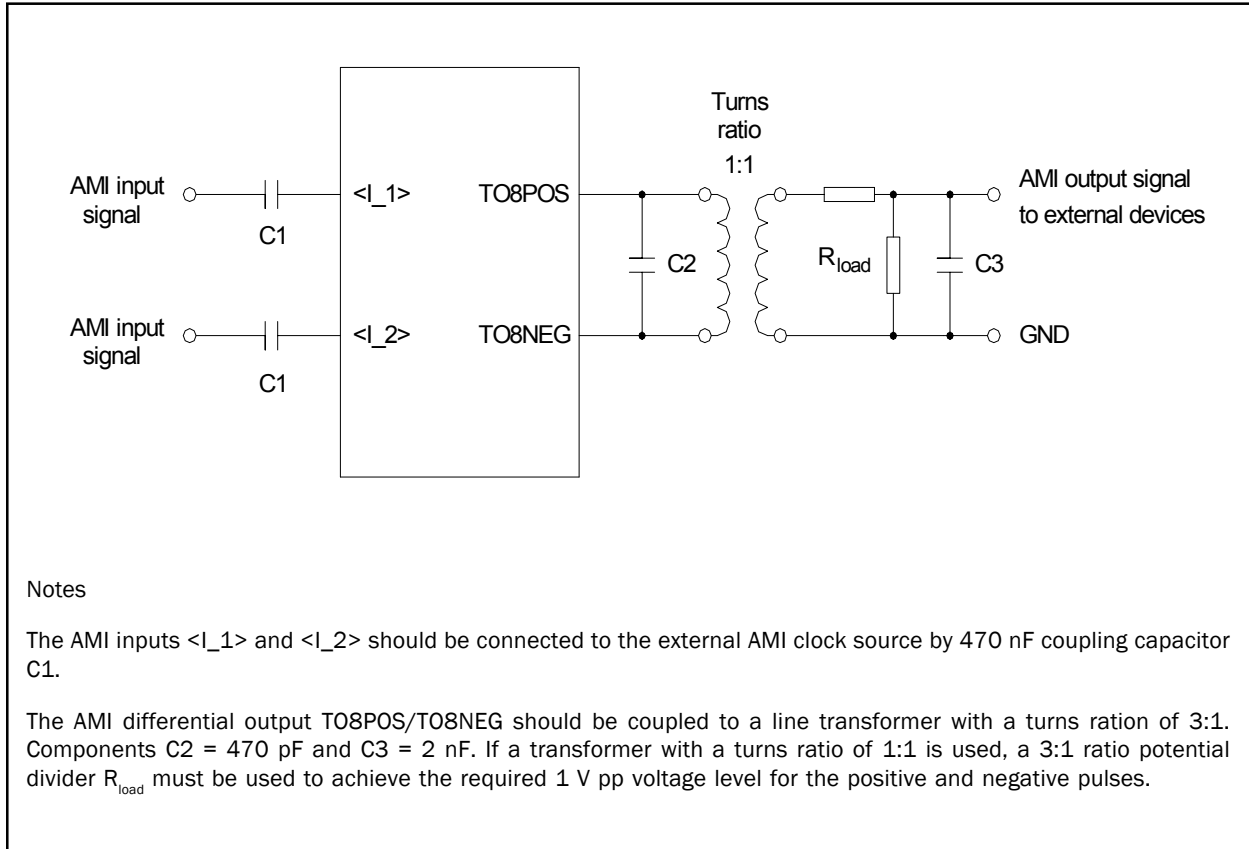
Table 24. DC Characteristics: Output Jitter Generation (Test Definition G.812)

Across all operating conditions, unless otherwise stated

Output jitter generation measured over 60 seconds interval, UI pp max measured using Vectron 6664 12.8 MHz TCXO on ICT Flexacom + 10 MHz reference from Wavetek 905.

Test definition	Filter used	UI spec	UI measurement on ACS8510 Rev 2
G.812 for 1.544 MHz	10 Hz to 40 kHz	UI _{pp} = 0.05	0.036 (Note 14)
G.812 for 155.52 MHz electrical	500 Hz to 1.3 MHz	UI _{pp} = 0.5	0.058 (Note 15)
G.812 for 2.048 MHz electrical	65 kHz to 1.3 MHz	UI _{pp} = 0.075	0.048 (Note 15)

Table 25. DC Characteristics: Output Jitter Generation (Test Definition ETS-300-462-3)

Across all operating conditions, unless otherwise stated

Output jitter generation measured over 60 seconds interval, UI pp max measured using Vectron 6664 12.8 MHz TCXO on ICT Flexacom + 10 MHz reference from Wavetek 905.

Test definition	Filter used	UI spec	UI measurement on ACS8510 Rev 2
ETS-300-462-3 for 2.048 MHz SEC	20 Hz to 100 kHz	UI _{pp} = 0.5	0.046 (Note 14)
ETS-300-462-3 for 2.048 MHz SEC (Filter spec 49 Hz to 100 kHz)	20 Hz to 100 kHz	UI _{pp} = 0.2	0.046 (Note 14)
ETS-300-462-3 for 2.048 MHz SSU	20 Hz to 100 kHz	UI _{pp} = 0.05	0.046 (Note 14)
ETS-300-462-3 for 155.52 MHz	500 Hz to 1.3 MHz	UI _{pp} = 0.5	0.058 (Note 15)
ETS-300-462-3 for 155.52 MHz	65 kHz to 1.3 MHz	UI _{pp} = 0.1	0.048 (Note 15)

Table 26. DC Characteristics: Output Jitter Generation (Test Definition GR-253-CORE)

Across all operating conditions, unless otherwise stated

Output jitter generation measured over 60 seconds interval, UI pp max measured using Vectron 6664 12.8 MHz TCXO on ICT Flexacom + 10 MHz reference from Wavetek 905.

Test definition	Filter used	UI spec	UI measurement on ACS8510 Rev 2
GR-253-CORE net i/f, 51.84 MHz	100 Hz to 400 kHz	UI _{pp} = 1.5	0.022 (Note 15)
GR-253-CORE net i/f, 51.84 MHz (Filter spec 20 kHz to 400 kHz)	18 kHz to 400 kHz	UI _{pp} = 0.15	0.019 (Note 15)
GR-253-CORE net i/f, 155.52 MHz	500 Hz to 1.3 MHz	UI _{pp} = 1.5	0.058 (Note 15)
GR-253-CORE net i/f, 155.52 MHz	65 kHz to 1.3 MHz	UI _{pp} = 0.15	0.048 (Note 15)
GR-253-CORE cat II elect i/f, 155.52 MHz	12 kHz to 400 kHz	UI _{pp} = 0.1	0.057 (Note 15)
		UI _{rms} = 0.01	0.006 (Note 15)
GR-253-CORE cat II elect i/f, 51.84 MHz	12 kHz to 1.3 MHz	UI _{pp} = 0.1	0.017 (Note 15)
		UI _{rms} = 0.01	0.003 (Note 15)
GR-253-CORE DS1 i/f, 1.544 MHz	10 Hz to 40 kHz	UI _{pp} = 0.1	0.036 (Note 14)
		UI _{rms} = 0.01	0.0055 (Note 14)

Table 27. DC Characteristics: Output Jitter Generation (Test Definition AT&T 62411)

Across all operating conditions, unless otherwise stated

Output jitter generation measured over 60 seconds interval, UI pp max measured using Vectron 6664 12.8 MHz TCXO on ICT Flexacom + 10 MHz reference from Wavetek 905.

Test definition	Filter used	UI spec	UI measurement on ACS8510 Rev 2
AT&T 62411 for 1.544 MHz (Filter spec 10 Hz to 8 kHz)	10 Hz to 40 kHz	$UI_{rms} = 0.02$	0.0055 (Note 14)
AT&T 62411 for 1.544 MHz	10 Hz to 40 kHz	$UI_{rms} = 0.025$	0.0055 (Note 14)
AT&T 62411 for 1.544 MHz	10 Hz to 40 kHz	$UI_{rms} = 0.025$	0.0055 (Note 14)
AT&T 62411 for 1.544 MHz	Broadband	$UI_{rms} = 0.05$	0.0055 (Note 14)

Table 28. DC Characteristics: Output Jitter Generation (Test Definition G.742)

Across all operating conditions, unless otherwise stated

Output jitter generation measured over 60 seconds interval, UI pp max measured using Vectron 6664 12.8 MHz TCXO on ICT Flexacom + 10 MHz reference from Wavetek 905.

Test definition	Filter used	UI spec	UI measurement on ACS8510 Rev 2
G.742 for 2.048 MHz	DC to 100 kHz	$UI_{pp} = 0.25$	0.047 (Note 14)
G.742 for 2.048 MHz (Filter spec 18 kHz to 100 kHz)	20 Hz to 100 kHz	$UI_{pp} = 0.05$	0.046 (Note 14)
G.742 for 2.048 MHz	20 Hz to 100 kHz	$UI_{pp} = 0.05$	0.046 (Note 14)

Table 29. DC Characteristics: Output Jitter Generation (Test Definition TR-NWT-000499)

Across all operating conditions, unless otherwise stated

Output jitter generation measured over 60 seconds interval, UI pp max measured using Vectron 6664 12.8 MHz TCXO on ICT Flexacom + 10 MHz reference from Wavetek 905.

Test definition	Filter used	UI spec	UI measurement on ACS8510 Rev 2
TR-NWT-000499 & G824 for 1.544 MHz	10 Hz to 40 kHz	$UI_{pp} = 5.0$	0.036 (Note 14)
TR-NWT-000499 & G824 for 1.544 MHz (Filter spec 8 kHz to 40 kHz)	10 Hz to 40 kHz	$UI_{pp} = 0.1$	0.036 (Note 14)

Table 30. DC Characteristics: Output Jitter Generation (Test Definition GR-1244-CORE)

Across all operating conditions, unless otherwise stated

Output jitter generation measured over 60 seconds interval, UI pp max measured using Vectron 6664 12.8 MHz TCXO on ICT Flexacom + 10 MHz reference from Wavetek 905.

Test definition	Filter used	UI spec	UI measurement on ACS8510 Rev 2
GR-1244-CORE for 1.544 MHz	>10 Hz	UI _{pp} = 0.05	0.036 (Note 14)

Notes for Tables 23 - 30

- Note 1. Filter used is that defined by test definition unless otherwise stated
- Note 2. 5 Hz bandwidth, 19.44 MHz direct lock
- Note 3. 5 Hz bandwidth, 8 kHz lock
- Note 4. 20 Hz bandwidth, 19.44 MHz direct lock
- Note 5. 20 Hz bandwidth, 8 kHz lock
- Note 6. 10 Hz bandwidth, 19.44 MHz direct lock
- Note 7. 10 Hz bandwidth, 8 kHz lock
- Note 8. 2.5 Hz bandwidth, 19.44 MHz direct lock
- Note 9. 2.5 Hz bandwidth, 8 kHz lock
- Note 10. 1.2 Hz bandwidth, 19.44 MHz direct lock
- Note 11. 1.2 Hz bandwidth, 8 kHz lock
- Note 12. 0.6 Hz bandwidth, 19.44 MHz direct lock
- Note 13. 0.6 Hz bandwidth, 8 kHz lock
- Note 14. 5 Hz bandwidth, 8 kHz lock, 2.048 MHz input
- Note 15. 5 Hz bandwidth, 8 kHz lock, 19.44 MHz input

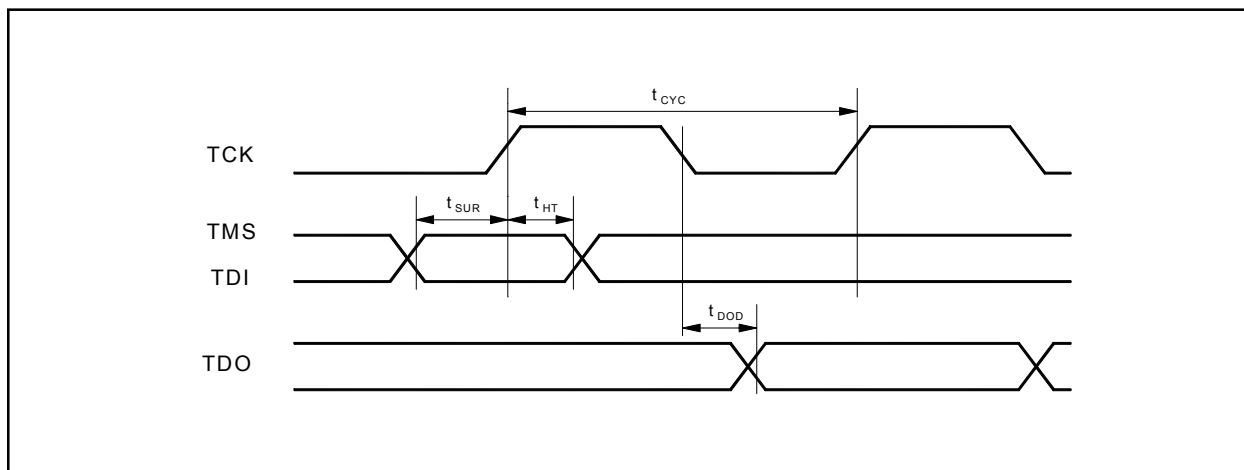
Figure 17. JTAG Timing

Table 31. JTAG Timing (for use with Figure 17)

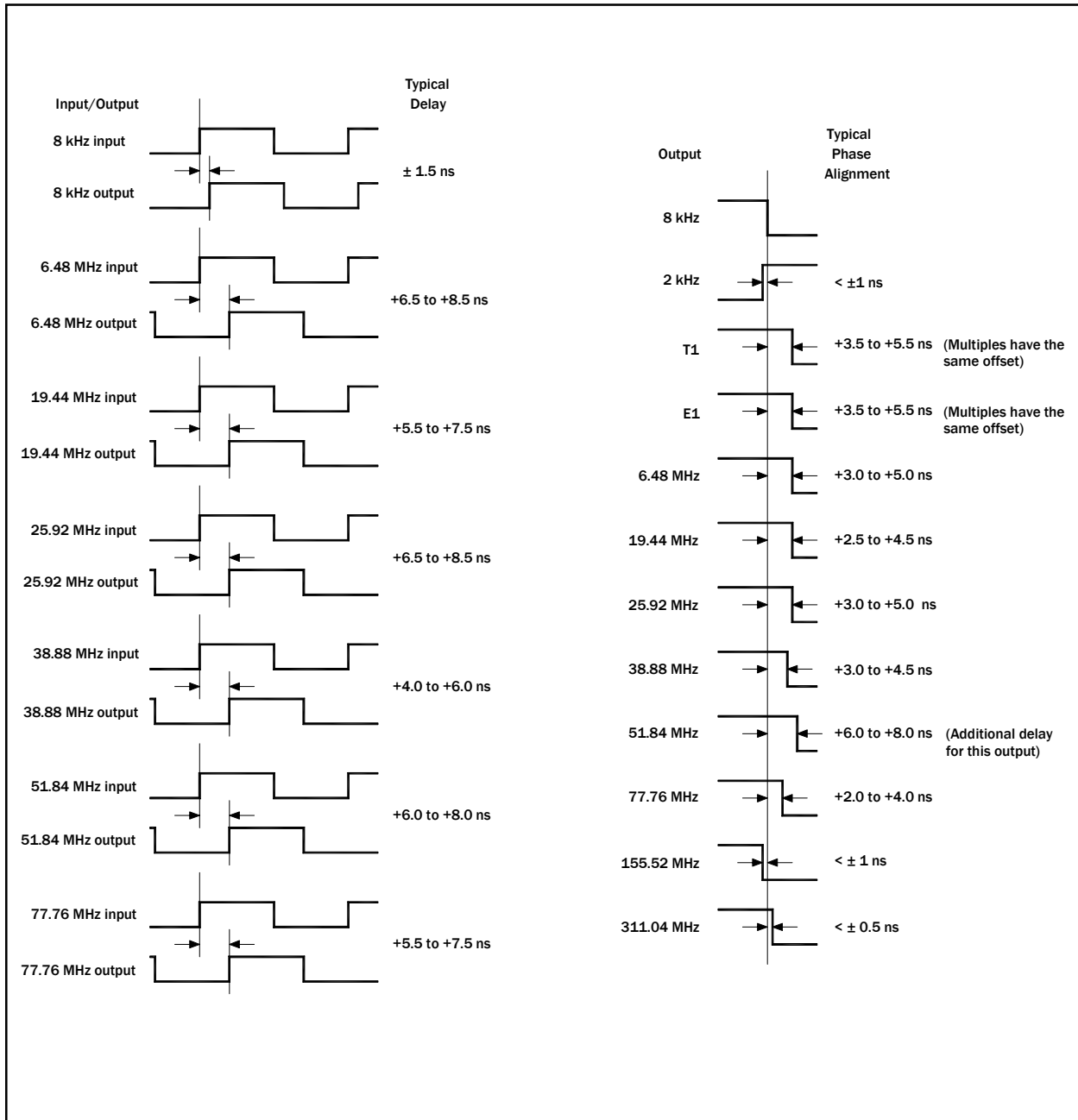
PARAMETER	SYMBOL	MIN	TYP	MAX	UNITS
Cycle time	t_{CYC}	50	-	-	ns
TMS/TDI to TCK rising edge time	t_{SUR}	3	-	-	ns
TCK rising to TMS/TDI hold time	t_{HT}	23	-	-	ns
TCK falling to TDO valid	t_{DOD}	-	-	5	ns

Figure 18. Input/Output Timing

Microprocessor Interface Timing

Motorola Mode

In MOTOROLA mode, the device is configured to interface with a microprocessor using a 680x0 type bus. The following figures show the timing diagrams of write and read accesses for this mode.

Figure 19. Read Access Timing in MOTOROLA Mode

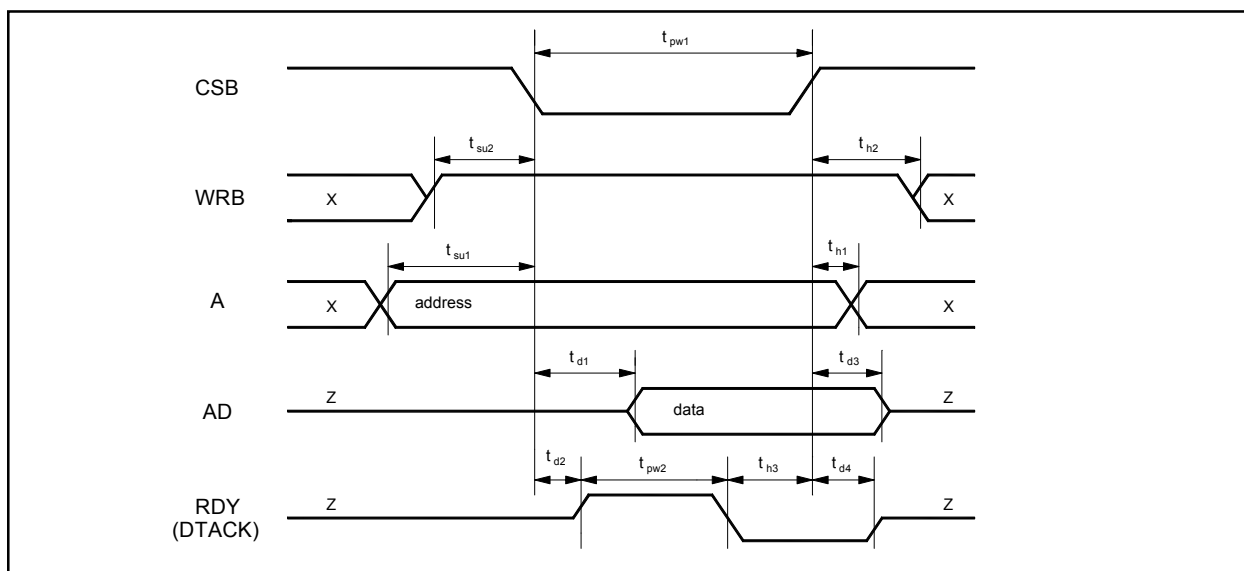
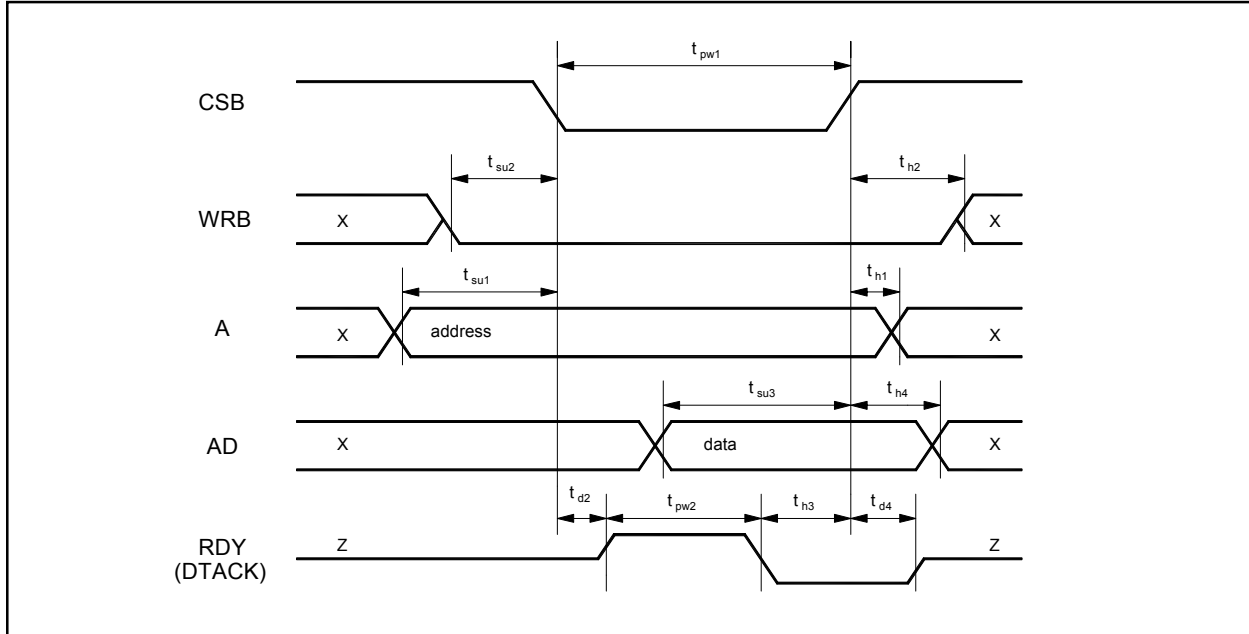

Table 32. Read Access Timing in MOTOROLA Mode (for use with Figure 19)

Symbol	Parameter	MIN	TYP	MAX
t_{su1}	Setup A valid to CSB _{falling edge}	0 ns	-	-
t_{su2}	Setup WRB valid to CSB _{falling edge}	0 ns	-	-
t_{d1}	Delay CSB _{falling edge} to AD valid	-	-	177 ns
t_{d2}	Delay CSB _{falling edge} to DTACK _{rising edge}	-	-	13 ns
t_{d3}	Delay CSB _{rising edge} to AD high-Z	-	-	0 ns
t_{d4}	Delay CSB _{rising edge} to RDY high-Z	-	-	7 ns
t_{pw1}	CSB low time	485 ns ⁽¹⁾	-	-
t_{pw2}	RDY high time	310 ns	-	472 ns
t_{h1}	Hold A valid after CSB _{rising edge}	0 ns	-	-
t_{h2}	Hold WRB high after CSB _{rising edge}	0 ns	-	-
t_{h3}	Hold CSB low after RDY _{falling edge}	0 ns	-	-
t_d	Time between consecutive accesses (CSB _{rising edge} to CSB _{falling edge})	320 ns	-	-

Note 1: Timing with RDY. If RDY not used, t_{pw1} becomes 178 ns.

Figure 20. Write Access Timing in MOTOROLA Mode

Table 33. Write Access Timing in MOTOROLA Mode (for use with Figure 20)

Symbol	Parameter	MIN	TYP	MAX
t_{su1}	Setup A valid to CSB _{falling edge}	0 ns	-	-
t_{su2}	Setup WRB valid to CSB _{falling edge}	0 ns	-	-
t_{su3}	Setup AD valid before CSB _{rising edge}	3 ns	-	-
t_{d2}	Delay CSB _{falling edge} to RDY _{rising edge}	-	-	13 ns
t_{d4}	Delay CSB _{rising edge} to RDY high-Z	-	-	7 ns
t_{pw1}	CSB low time	485 ns ⁽¹⁾	-	-
t_{pw2}	RDY high time	310 ns	-	472 ns
t_{h1}	Hold A valid after CSB _{rising edge}	3 ns	-	-
t_{h2}	Hold WRB low after CSB _{rising edge}	0 ns	-	-
t_{h3}	Hold CSB low after RDY _{falling edge}	0 ns	-	-
t_{h4}	Hold AD valid after CSB _{rising edge}	4 ns	-	-
t_p	Time between consecutive accesses (CSB _{rising edge} to CSB _{falling edge})	320 ns	-	-

Note 1: Timing with RDY. If RDY not used, t_{pw1} becomes 178 ns.

Intel Mode

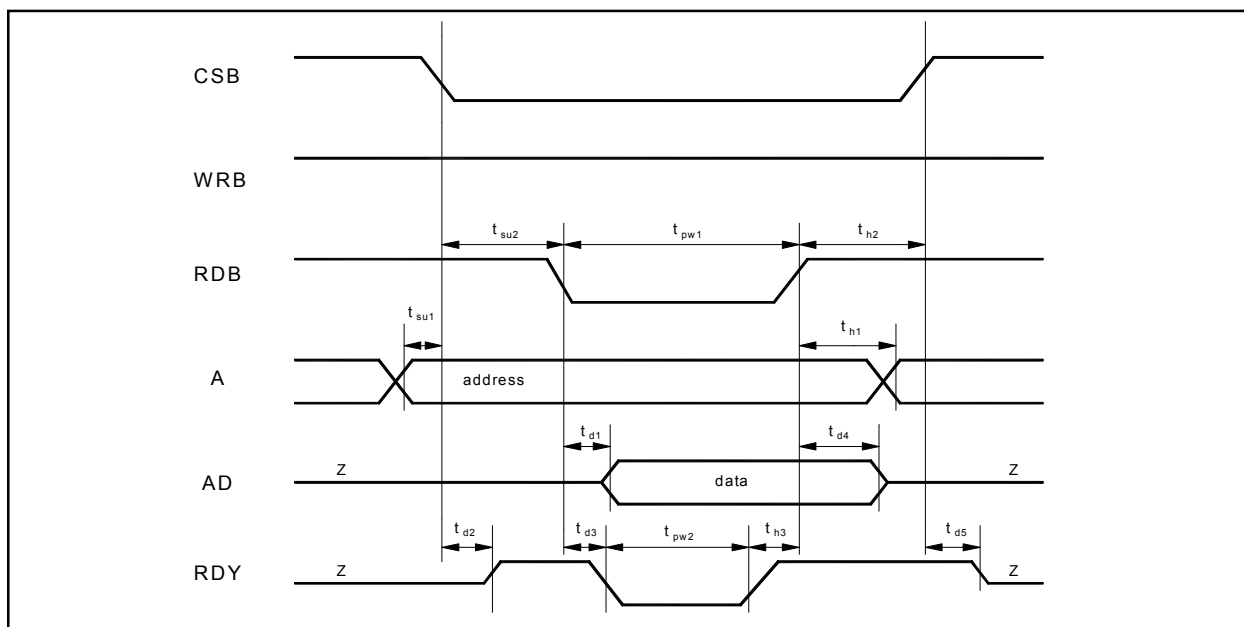
In INTEL mode, the device is configured to interface with a microprocessor using a 80x86 type bus. The following figures show the timing diagrams of write and read accesses for this mode.

Figure 21. Read Access Timing in INTEL Mode

Table 34. Read Access Timing in INTEL Mode (for use with Figure 21)

Symbol	Parameter	MIN	TYP	MAX
t_{su1}	Setup A valid to CSB _{falling edge}	0 ns	-	-
t_{su2}	Setup CSB _{falling edge} to RDB _{falling edge}	0 ns	-	-
t_{d1}	Delay RDB _{falling edge} to AD valid	-	-	177 ns
t_{d2}	Delay CSB _{falling edge} to RDY active	-	-	13 ns
t_{d3}	Delay RDB _{falling edge} to RDY _{falling edge}	-	-	14 ns
t_{d4}	Delay RDB _{rising edge} to AD high-Z	-	-	10 ns
t_{d5}	Delay CSB _{rising edge} to RDY high-Z	-	-	9 ns
t_{pw1}	RDB low time	486 ns ⁽¹⁾	-	-
t_{pw2}	RDY low time	310 ns	-	472 ns
t_{h1}	Hold A valid after RDB _{rising edge}	0 ns	-	-
t_{h2}	Hold CSB low after RDB _{rising edge}	0 ns	-	-
t_{h3}	Hold RDB low after RDY _{rising edge}	0 ns	-	-
t_p	Time between consecutive accesses (RDB _{rising edge} to RDB _{falling edge} , or RDB _{rising edge} to WRB _{falling edge})	320 ns	-	-

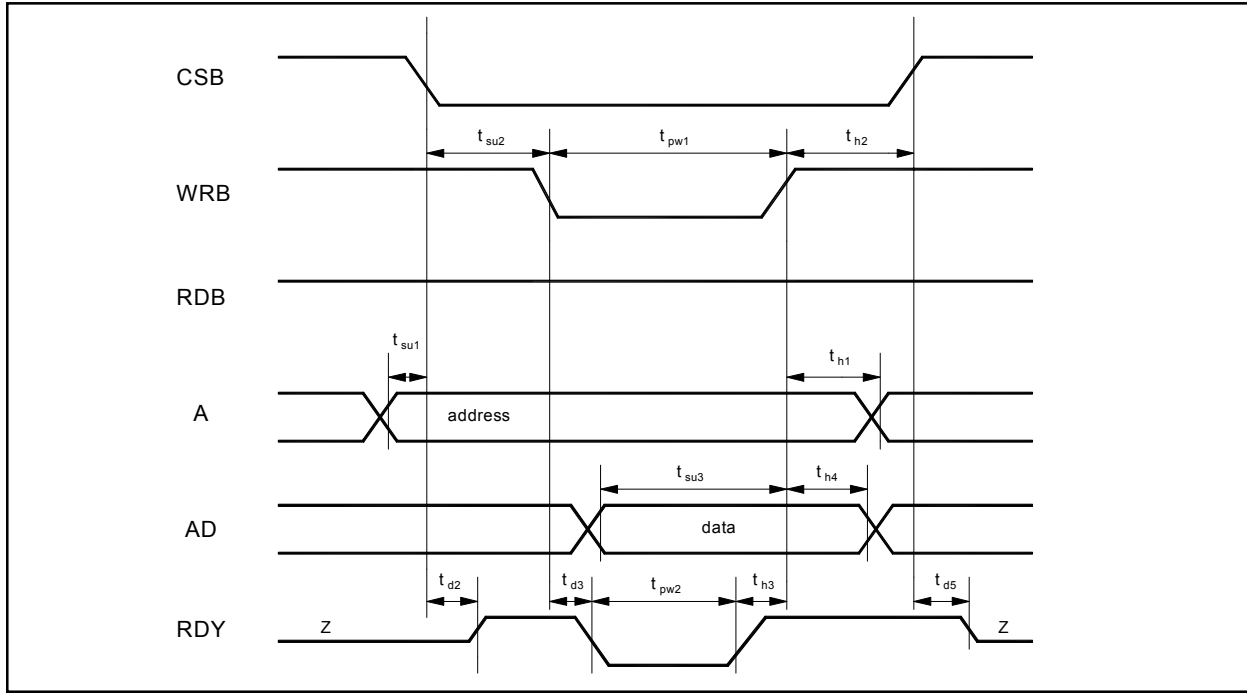
Note 1: Timing with RDY. If RDY not used, t_{pw1} becomes 180 ns.

Figure 22. Write Access Timing in INTEL Mode

Table 35. Write Access Timing in INTEL Mode (for use with Figure 22)

Symbol	Parameter	MIN	TYP	MAX
t_{su1}	Setup A valid to CSB _{falling edge}	0 ns	-	-
t_{su2}	Setup CSB _{falling edge} to WRB _{falling edge}	0 ns	-	-
t_{su3}	Setup AD valid to WRB _{rising edge}	3 ns	-	-
t_{d2}	Delay CSB _{falling edge} to RDY active	-	-	13 ns
t_{d3}	Delay WRB _{falling edge} to RDY _{falling edge}	-	-	14 ns
t_{d5}	Delay CSB _{rising edge} to RDY high-Z	-	-	9 ns
t_{pw1}	WRB low time	486 ns ⁽¹⁾	-	-
t_{pw2}	RDY low time	310 ns	-	472 ns
t_{h1}	Hold A valid after WRB _{rising edge}	170 ns ⁽²⁾	-	-
t_{h2}	Hold CSB low after WRB _{rising edge}	0 ns	-	-
t_{h3}	Hold WRB low after RDY _{rising edge}	0 ns	-	-
t_{h4}	Hold AD valid after WRB _{rising edge}	4 ns	-	-
t_p	Time between consecutive accesses (WRB _{rising edge} to WRB _{falling edge} , or WRB _{rising edge} to RDB _{falling edge})	320 ns	-	-

Note 1: Timing with RDY. If RDY not used, t_{pw1} becomes 180 ns.

Note 2: Timing if t_{h2} is greater than 170 ns, otherwise 5 ns after CSB rising edge.

Multiplexed Mode

In MULTIPLEXED mode, the device is configured to interface with a microprocessor using a multiplexed address/data bus. The following figures show the timing diagrams of write and read accesses for this mode.

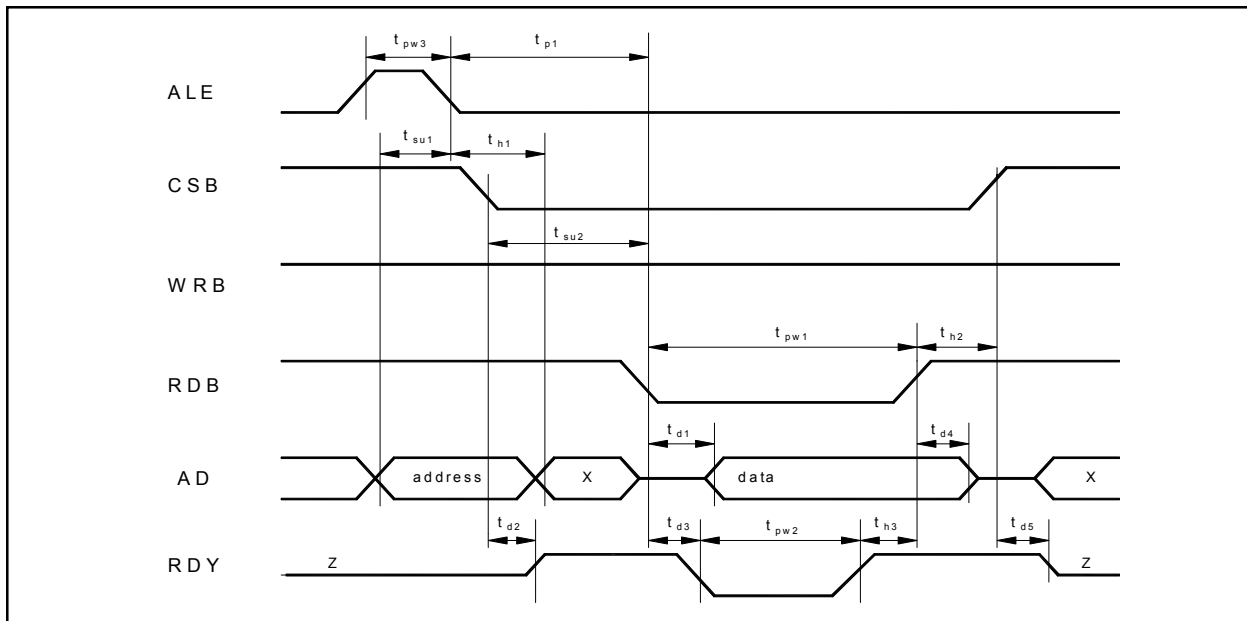
Figure 23. Read Access Timing in MULTIPLEXED Mode

Table 36. Read Access Timing in MULTIPLEXED Mode (for use with Figure 23)

Symbol	Parameter	MIN	TYP	MAX
t_{su1}	Setup AD address valid to ALE _{falling edge}	2 ns	-	-
t_{su2}	Setup CSB _{falling edge} to RDB _{falling edge}	0 ns	-	-
t_{d1}	Delay RDB _{falling edge} to AD data valid	-	-	177 ns
t_{d2}	Delay CSB _{falling edge} to RDY active	-	-	13 ns
t_{d3}	Delay RDB _{falling edge} to RDY _{falling edge}	-	-	15 ns
t_{d4}	Delay RDB _{rising edge} to AD data high-Z	-	-	9 ns
t_{d5}	Delay CSB _{rising edge} to RDY high-Z	-	-	10 ns
t_{pw1}	RDB low time	487 ns ⁽¹⁾	-	-
t_{pw2}	RDY low time	310 ns	-	472 ns
t_{pw3}	ALE high time	2 ns	-	-
t_{h1}	Hold AD address valid after ALE _{falling edge}	3 ns	-	-
t_{h2}	Hold CSB low after RDB _{rising edge}	0 ns	-	-
t_{h3}	Hold RDB low after RDY _{rising edge}	0 ns	-	-
t_{p1}	Time between ALE _{falling edge} and RDB _{falling edge}	0 ns	-	-
t_{p2}	Time between consecutive accesses (RDB _{rising edge} to ALE _{rising edge})	320 ns	-	-

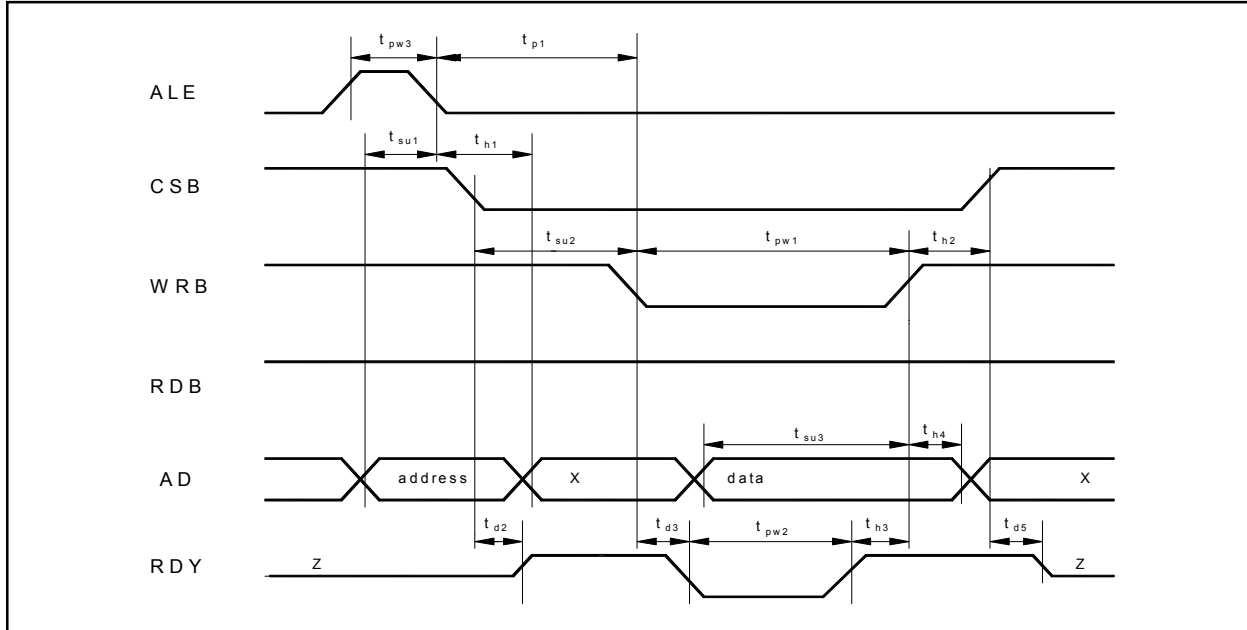
Note 1: Timing with RDY. If RDY not used, t_{pw1} becomes 180 ns.

Figure 24. Write Access Timing in MULTIPLEXED Mode

Table 37. Write Access Timing in MULTIPLEXED Mode (for use with Figure 24)

Symbol	Parameter	MIN	TYP	MAX
t_{su1}	Setup AD address valid to ALE _{falling edge}	2 ns	-	-
t_{su2}	Setup CSB _{falling edge} to WRB _{falling edge}	0 ns	-	-
t_{su3}	Setup AD data valid to WRB _{rising edge}	3 ns	-	-
t_{d2}	Delay CSB _{falling edge} to RDY active	-	-	13 ns
t_{d3}	Delay WRB _{falling edge} to RDY _{falling edge}	-	-	15 ns
t_{d5}	Delay CSB _{rising edge} to RDY high-Z	-	-	9 ns
t_{pw1}	WRB low time	487 ns ⁽¹⁾	-	-
t_{pw2}	RDY low time	310 ns	-	472 ns
t_{pw3}	ALE high time	2 ns	-	-
t_{h1}	Hold AD address valid after ALE _{falling edge}	3 ns	-	-
t_{h2}	Hold CSB low after WRB _{rising edge}	0 ns	-	-
t_{h3}	Hold WRB low after RDY _{rising edge}	0 ns	-	-
t_{h4}	AD data hold valid after WRB _{rising edge}	4 ns	-	-
t_{p1}	Time between ALE _{falling edge} and WRB _{falling edge}	0 ns	-	-
t_{p2}	Time between consecutive accesses (WRB _{rising edge} to ALE _{rising edge})	320 ns	-	-

Note 1: Timing with RDY. If RDY not used, t_{pw1} becomes 180 ns.

Serial Mode

In Serial mode, the device is configured to interface with a serial microprocessor bus. The combined minimum High and Low times for SCLK define the maximum clock rate.

For Write access this is 2.77 MHz (360 ns). For Read access the maximum SCLK rate is slightly slower and is affected by the setting of CLKE, being either 2.0 MHz (500 ns) or 1 MHz (1 us).

This mismatch in rates is caused by the sampling technique used to detect the end of the address field in Read mode. It takes up to 3 cycles of an internal 6.40 MHz clock to start the Read process following receipt of the final address bit. This is 468 ns. The Read data is then decoded and clocked out onto SDO directly using SCLK. With CLKE=1, the falling edge of SCLK is used to clock out the SDO. With CLKE=0, the rising edge of SCLK is used to clock out the SDO.

A minimum period of 500 ns (468 capture plus 32 decode) is required between the final address bit and clocking it out onto SDO. This means that to guarantee the correct operation of the Serial interface, with CLKE=0, SCLK has a maximum clock rate of 2 MHz. With CLKE=1, SCLK has a maximum clock rate of 1 MHz.

SCLK is not required to run between accesses (i.e., when CSB = 1). The following Figures show the timing diagrams for Write and Read access for this mode.

Figure 25. Read Access Timing in Serial Mode

Table 38. Read Access Timing in SERIAL Mode (for use with Figure 25)

Symbol	Parameter	MIN	TYP	MAX
t_{su1}	Setup SDI valid to SCLK _{rising edge}	0 ns	-	-
t_{su2}	Setup CSB _{falling edge} to SCLK _{rising edge}	160 ns	-	-
t_{d1}	Delay SCLK _{rising edge} (SCLK _{falling edge} for CLKE = 1) to SDO valid	-	-	17 ns
t_{d2}	Delay CSB _{rising edge} to SDO high-Z	-	-	10 ns
t_{pw1}	SCLK low time CLKE = 0 CLKE = 1	250ns 500ns	-	-
t_{pw2}	SCLK high time CLKE = 0 CLKE = 1	250ns 500ns	-	-
t_{h1}	Hold SDI valid after SCLK _{rising edge}	170 ns	-	-
t_{h2}	Hold CSB low after SCLK _{rising edge} for CLKE = 0 Hold CSB low after SCLK _{falling edge} for CLKE = 1	5 ns	-	-
t_p	Time between consecutive accesses (CSB _{rising edge} to CSB _{falling edge})	160 ns	-	-

Figure 26. Write Access Timing in SERIAL Mode

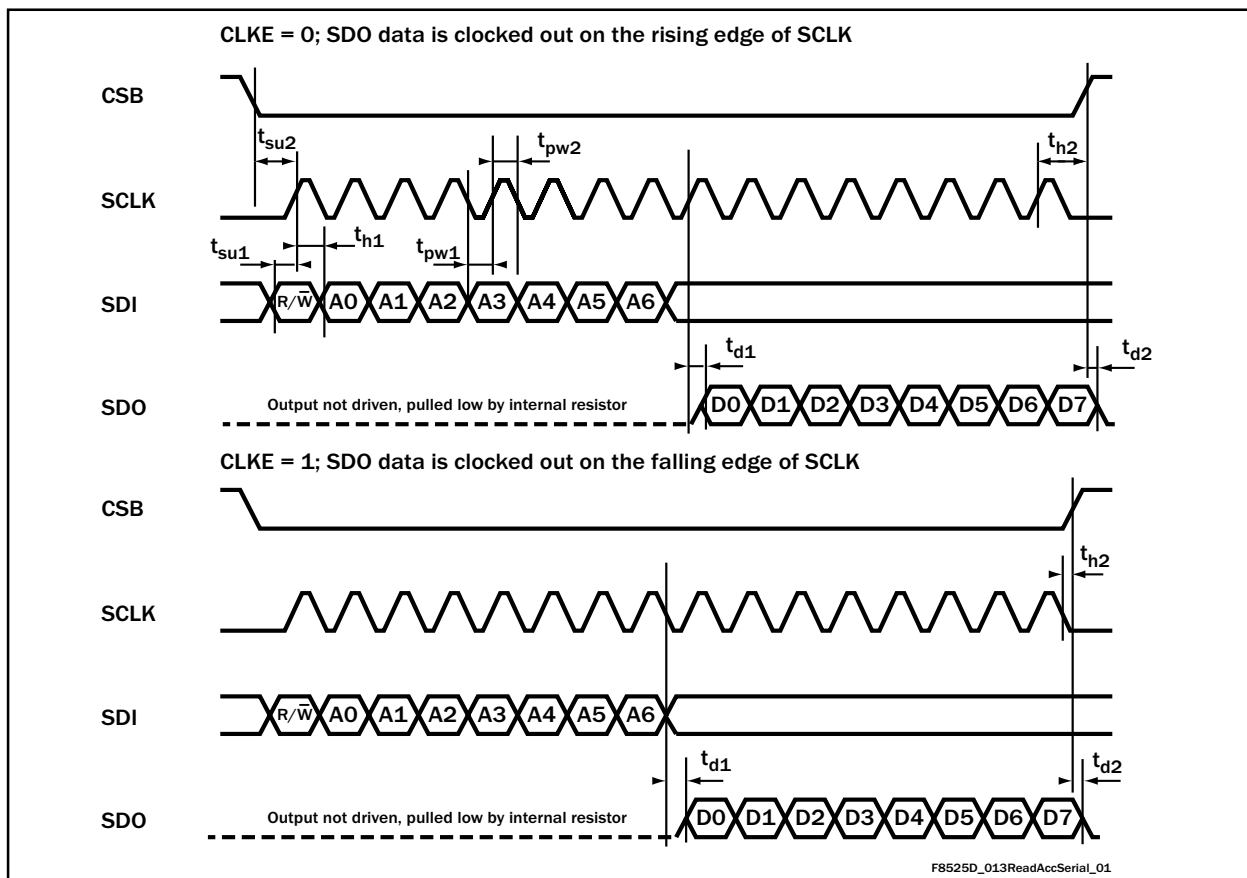
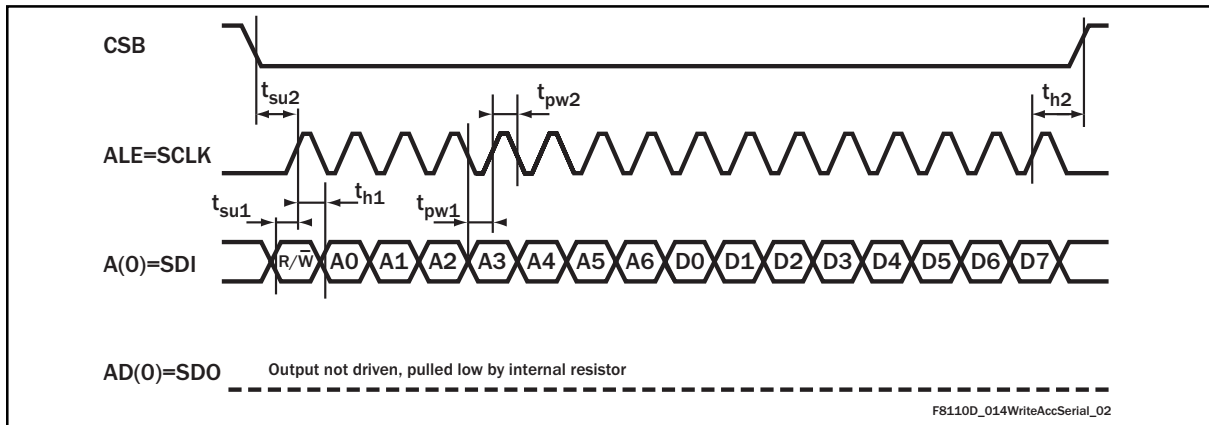

Table 39. Write Access Timing in SERIAL Mode (for use with Figure 26)

Symbol	Parameter	MIN	TYP	MAX
t_{su1}	Setup SDI valid to SCLK _{rising edge}	0 ns	-	-
t_{su2}	Setup CSB _{falling edge} to SCLK _{rising edge}	160 ns	-	-
t_{pw1}	SCLK low time	180 ns	-	-
t_{pw2}	SCLK high time	180 ns	-	-
t_{h1}	Hold SDI valid after SCLK _{rising edge}	170 ns	-	-
t_{h2}	Hold CSB low after SCLK _{rising edge}	5 ns	-	-
t_p	Time between consecutive accesses (CSB _{rising edge} to CSB _{falling edge})	160 ns	-	-

EPROM Mode

In EPROM mode, the ACS8510 takes control of the bus as Master, and reads the device set-up from an AMD AM27C64 type EPROM at lowest speed (250ns), after device start-up (system reset). The EPROM access state machine in the up interface sequences the accesses.

Further details can be found in the AMD AM27C64 data sheet.

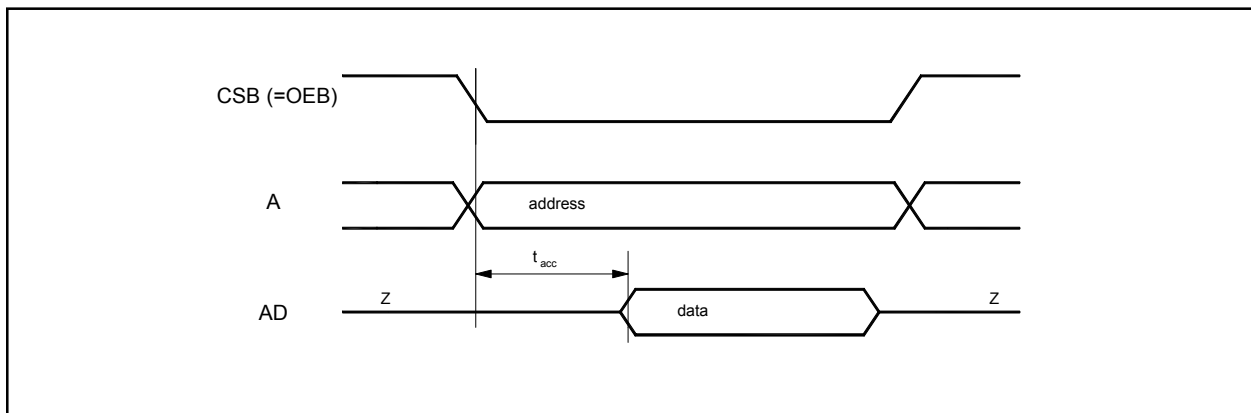
Figure 27. Access Timing in EPROM Mode

Table 40. Access Timing in EPROM Mode (for use with Figure 27)

Symbol	Parameter	MIN	TYP	MAX
t_{acc}	Delay CSB _{falling edge} or A change to AD valid	-	-	920 ns

Package Information
Figure 28. LQFP Package

Table 41. 100 Pin LQFP Package Dimension Data (for use with Figure 28)

100 LQFP Package Dimensions In mm	D/E	D1/E1	A	A1	A2	e	AN1	AN2	AN3	AN4	R1	R2	L	L1	S	b	b1	c	c1
Min			1.40	0.05	1.35		11°	11°	0°	0°	0.08	0.08	0.45		0.20	0.17	0.17	0.09	0.09
Nom	16.00	14.00	1.50	0.10	1.40	0.50	12°	12°	-	3.5°	-	-	0.60	1.00 (ref)	-	0.22	0.20	-	-
Max			1.60	0.15	1.45		13°	13°	-	7°	-	0.20	0.75		-	0.27	0.23	0.20	0.16

Thermal Conditions

The device is rated for full temperature range when this package is used with a 4 layer or more PCB. Copper coverage must exceed 50%. All pins must be soldered to the PCB. Maximum operating temperature must be reduced when the device is used with a PCB with less than these requirements.

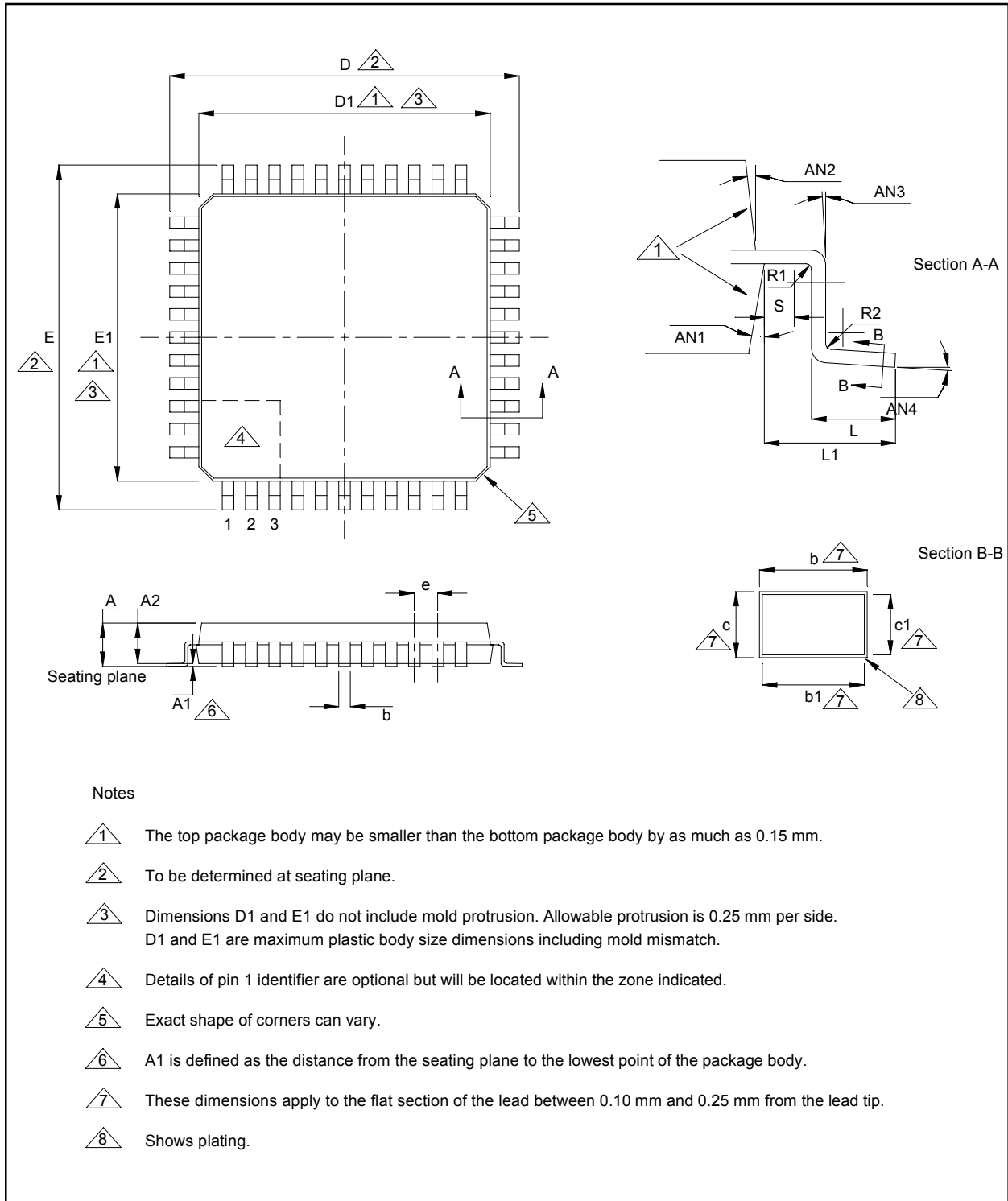
Figure 29. Typical 100 Pin LQFP Footprint

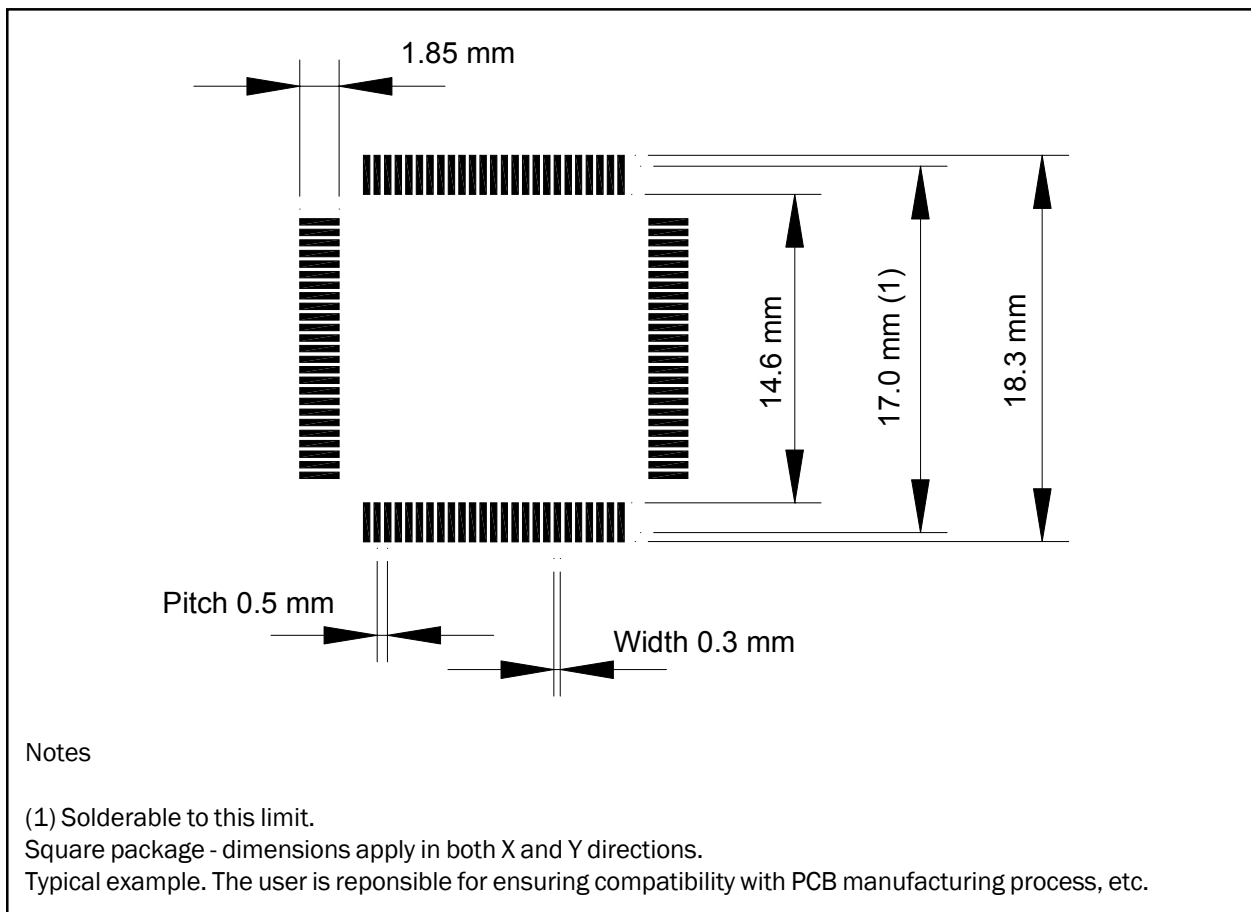

Application Information

Figure 30. Simplified Application Schematic

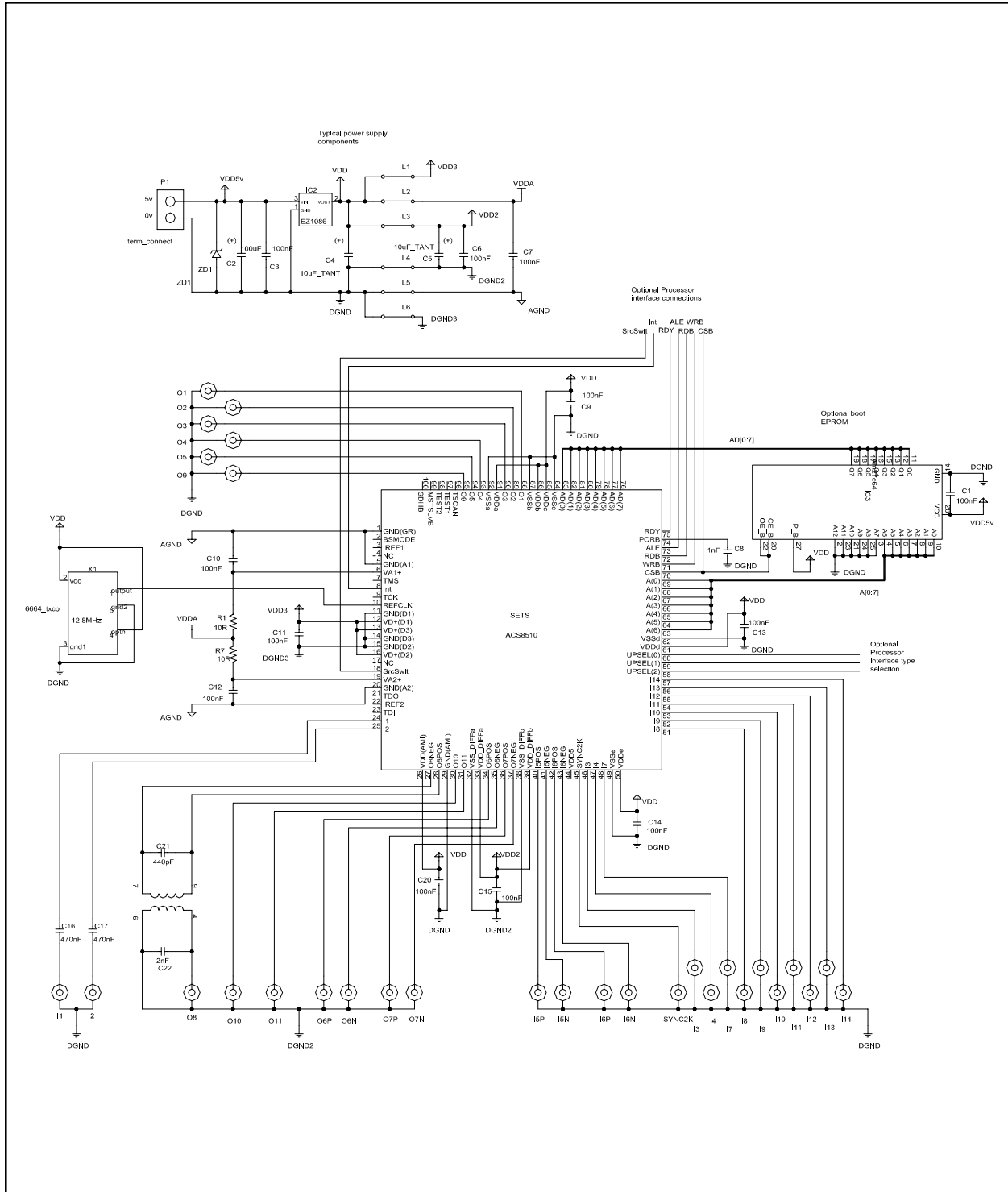

Revision History**Table 42. Changes from Revision 1.06 to 2.00 September 2003**

Item	Section	Page	Description
1	Non-Revertive Mode	36-37	Updated description of Non-Revertive Mode Operation

Ordering Information

PART NUMBER	DESCRIPTION
ACS8510 Rev2.1	SONET/SDH Synchronisation, 100 pin LQFP

Disclaimers

Life support - This product is not designed or intended for use in life support equipment, devices or systems, or other critical applications. This product is not authorized or warranted by Semtech Corporation for such use.

Right to change - Semtech Corporation reserves the right to make changes, without notice, to this product. Customers are advised to obtain the latest version of the relevant information before placing orders.

Compliance to relevant standards - Operation of this device is subject to the user's implementation, and design practices. The user is responsible to ensure equipment using this device is compliant to any relevant standards.

For additional information, contact the following:

Semtech Corporation Advanced Communications Products

E-Mail: sales@semtech.com acsupport@semtech.com

Internet: <http://www.semtech.com>

USA: Mailing Address: P.O. Box 6097, Camarillo, CA 93011-6097

Street Address: 200 Flynn Road, Camarillo, CA 93012-8790

Tel: +1 805 498 2111, Fax: +1 805 498 3804

FAR EAST: 11F, No. 46, Lane 11, Kuang Fu North Road, Taipei, Taiwan, R.O.C.

Tel: +886 2 2748 3380, Fax: +886 2 2748 3390



EUROPE: Units 2 & 3 Park Court, Premier Way, Abbey Park Industrial Estate,

Romsey, Hampshire, SO51 9DN, UK

Tel: +44 1794 527 600, Fax: +44 1794 527 601

Looking for pricing, stock, or lifecycle information?

Click below to explore more details on WIN SOURCE:

-  [View ACS8510 on WIN SOURCE](#)
-  [Semtech Corporation](#) Information

Optimize Your Supply Chain with WIN SOURCE Solutions

-  Global Sourcing Solution
-  Obsolete Management
-  Cost Control Management
-  Shortage Management
-  Alternative Solution
-  Excess Inventory Management