



THE DATASHEET OF ACS4025S





ACS402-5SB4

ASD™

AC Switch Family

QUAD AC LINE SWITCH ARRAY

MAIN APPLICATIONS

- AC on-off static switching in appliance & industrial control systems
- Drive of low power high inductive or resistive loads like:
 - relay, valve, solenoid, dispenser
 - pump, fan, micro-motor
 - low power lamp bulb, door lock

FEATURES

- 4 high voltage AC switch array
- Blocking voltage: $V_{DRM} / V_{RRM} = 500V$
- Clamping voltage: $V_{CL} = 600V$
- Nominal current: $I_{T(RMS)} = 0.2 A$ per switch
- Nominal current: $I_{T(RMS)} = 0.4 A$ for the total array
- Switch integrated driver
- Triggering current is sourced by the gate
- Gate triggering current : $I_{GT} < 10 mA$

BENEFITS

- Needs no external overvoltage protection.
- Enables the equipment to meet IEC61000-4-5 standard.
- Miniaturizes 4 switches in 1 package.
- Reduces the switch component count by up to 80%.
- Interfaces directly with the microcontroller.
- Eliminates any stressing gate kick back on the microcontroller.

DESCRIPTION

The ACS402 belongs to the AC line switches array family built around the ASD™ concept. This high performance device includes 4 bi-directional a.c. switches able to control an 0.2 A resistive or inductive load device.

Each ACS™ switch integrates a high voltage clamping structure to absorb the inductive turn off energy and a gate level shifter driver to separate the digital controller from each main switch. It is triggered with a negative gate current flowing out of the gate pin.

For further technical information, please refer to AN1172 the Application note.

ASD and ACS are a trademarks of STMicroelectronics .

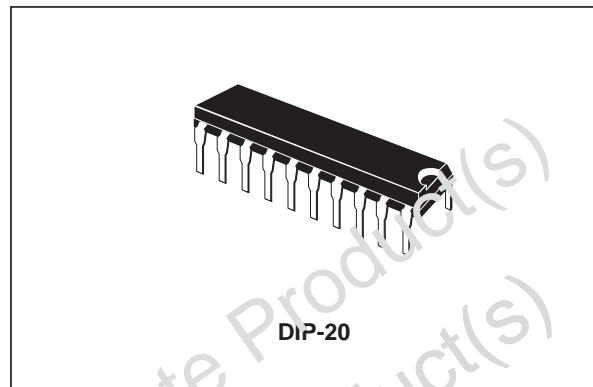

PIN OUT CONNECTION

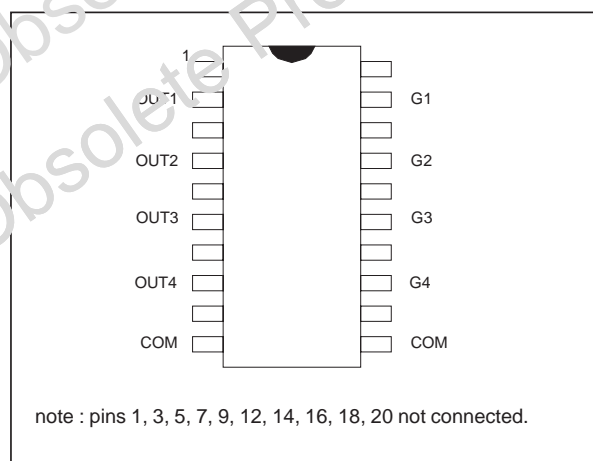

FUNCTIONAL DIAGRAM

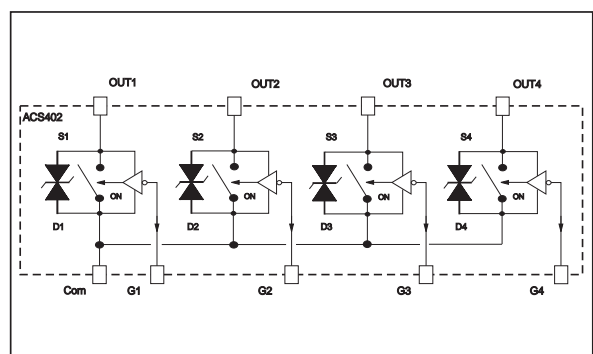

ACS402-5SB4

ABSOLUTE RATINGS (limiting values)

Symbol	Parameter		Value	Unit	
V_{DRM} / V_{RRM}	Repetitive peak off-state voltage		$T_j = 125\text{ °C}$	500	V
$I_{T(RMS)}$	RMS on-state current full cycle sine wave 50 to 60 Hz	per switch	$T_{amb} = 110\text{ °C}$	0.2	A
		total array	$T_{amb} = 90\text{ °C}$	0.4	A
I_{TSM}	Non repetitive surge peak on-state current T_j initial = 25°C, full cycle sine wave	F = 50 Hz		5	A
		F = 60 Hz		5.5	A
dI/dt	Critical rate of repetitive rise of on-state current $I_G = 20\text{mA}$ ($t_r = 100\text{ns}$)	F = 120 Hz		20	A/ μs
V_{PP}	Non repetitive line peak pulse voltage	note 1		2	kV
T_{stg}	Storage temperature range			- 40 to + 150	°C
T_j	Operating junction temperature range			- 30 to + 125	°C
T_l	Maximum lead temperature for soldering during 10s			260	°C

Note 1: according to test described by IEC61000-4-5 standard & Figure 3.

SWITCH GATE CHARACTERISTICS (maximum values)

Symbol	Parameter	Value	Unit
$P_{G(AV)}$	Average gate power dissipation	0.1	W
I_{GM}	Peak gate current ($t_p = 20\mu\text{s}$)	1	A
V_{GM}	Peak positive gate voltage (respect to the pin COM)	5	V

THERMAL RESISTANCE

Symbol	Parameter	Value	Unit
$R_{th(j-a)}$	Junction to ambient	90	°C/W

ELECTRICAL CHARACTERISTICS PER SWITCH

For either positive or negative polarity of pin OUT1, OUT2, OUT3, OUT4 voltage respect to pin COM voltage.

Symbol	Test conditions		Values	Unit
I_{GT}	$V_D = 12\text{V}$ $R_L = 140\Omega$	$T_j = 25\text{°C}$	MAX. 10	mA
V_{GT}	$V_D = 12\text{V}$ $R_L = 140\Omega$	$T_j = 25\text{°C}$	MAX. 1	V
V_{GD}	$V_{OUT} = V_{DRM}$ $R_L = 3.3\text{k}\Omega$	$T_j = 125\text{°C}$	MIN. 0.15	V
I_H	$I_{OUT} = 100\text{mA}$ gate open	$T_j = 25\text{°C}$	TYP. 25	mA
			MAX. 60	mA
I_L	$I_G = 20\text{mA}$	$T_j = 25\text{°C}$	TYP. 30	mA
			MAX. 65	mA
V_{TM}	$I_{OUT} = 0.3\text{A}$ $t_p = 500\mu\text{s}$	$T_j = 25\text{°C}$	MAX. 1.1	V
I_{DRM} / I_{RRM}	$V_{OUT} = V_{DRM}$ $V_{OUT} = V_{RRM}$	$T_j = 25\text{°C}$	MAX. 2	μA
		$T_j = 125\text{°C}$	MAX. 200	μA
dV/dt	$V_{OUT} = 400\text{V}$ gate open	$T_j = 110\text{°C}$	MIN. 500	V/ μs
(dI/dt) _C	(dV/dt) _C = 10V/ μs	$T_j = 110\text{°C}$	MIN. 0.1	A/ms
V_{CL}	$I_{CL} = 1\text{mA}$ $t_p = 1\text{ms}$	$T_j = 25\text{°C}$	TYP. 600	V

AC LINE SWITCH BASIC APPLICATION

The ACS402 device is well adapted to washing machines, dishwashers, tumble driers, refrigerators, water heaters and cookware. It has been designed especially to switch ON and OFF low power loads such as solenoids, valves, relays, micro-motors, pumps, fans, door locks and low power lamp bulbs.

Pin COM: Common drive reference to connect to the power line neutral

Pin G: Switch Gate input to connect to the digital controller through the resistor

Pin OUT: Switch Output to connect to the load

Each ACS™ switch is triggered with a negative gate current flowing out of the gate pin G. It can be driven directly by the digital controller through a resistor as shown on the typical application diagram. No protection device are required between the gates and common terminals.

In appliance systems, this ACS™ switch intends to drive low power load in full cycle ON / OFF mode. The turn off commutation characteristics of these loads can be classified in 3 groups as shown in Table 1.

Thanks to its thermal and turn-off commutation performance, each switch of the ACS402 is able to drive an inductive or resistive load up to 0.2 A with no additional turn-off snubber.

Table 1: Load grouping versus their turn off commutation requirement (230V AC applications).

LOAD	POWER (VA)	POWER FACTOR	RMS LOAD CURRENT (A)	$(dI_{OUT}/dt)_c$ (A/ms)	$(dV_{OUT}/dt)_c$ (V/ μ s)
Door lock Bulb Lamp	< 40	1	< 0.2	< 0.1	< 0.15
Relay Valve Dispenser Micro-motor Solenoid	< 20	> 0.7	< 0.1	< 0.05	< 2
Pump Fan	< 40	> 0.2	< 0.2	< 0.1	< 10

(*): Measured with an ACS402 switch

TYPICAL APPLICATION DIAGRAM

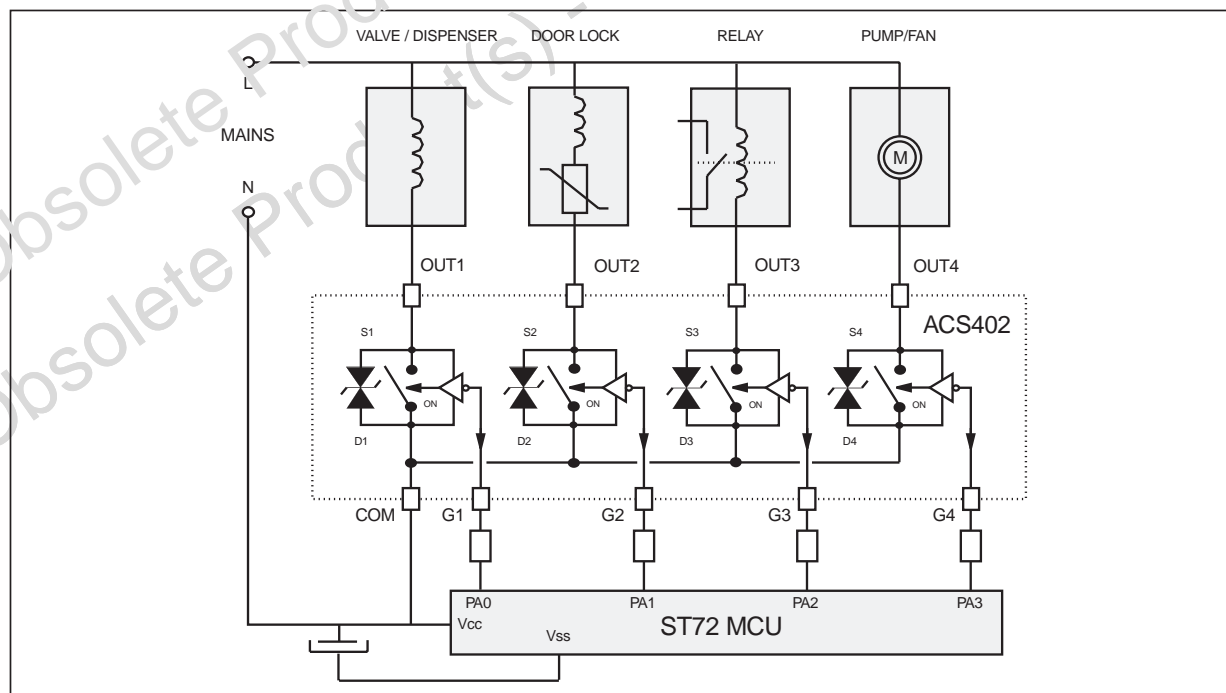

ACS402-5SB4

HIGH INDUCTIVE SWITCH-OFF OPERATION

At the end of the last conduction half-cycle, the load current reaches the holding current level I_H , and the ACS™ switch turns off. Because of the inductance L of the load, the current flows through the avalanche diode D and decreases linearly to zero. During this time, the voltage across the switch is limited to the clamping voltage V_{CL} .

The energy stored in the inductance of the load depends on the holding current I_H and the inductance (up to 10 H); it can reach about 20 mJ and is dissipated in the clamping section that is especially designed for that purpose.

Fig 1: Turn-off operation of the ACS402 switch with an electro valve: waveform of the gate current I_G , pin OUT current I_{OUT} & voltage V_{OUT} .

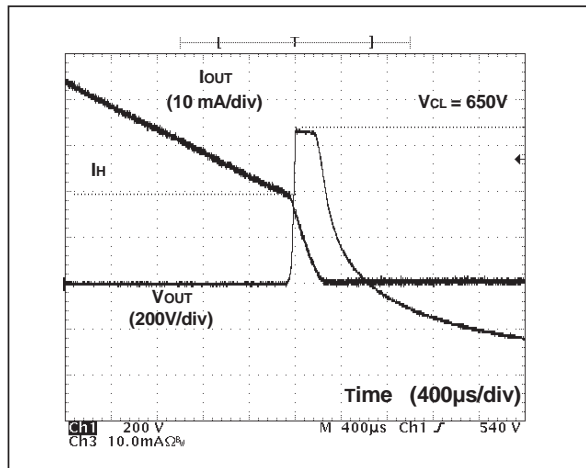
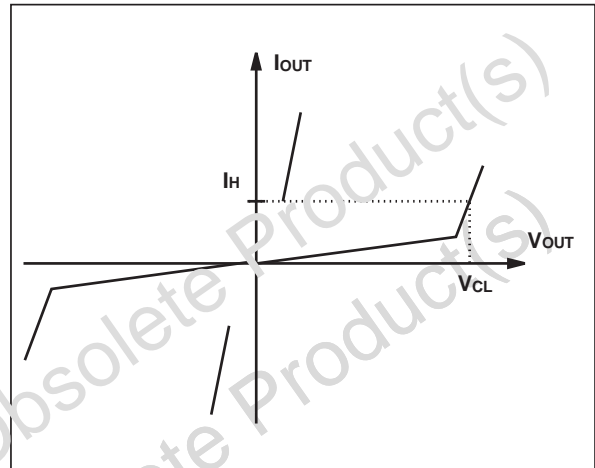

Fig 2: ACS402 switch static characteristic.



AC LINE TRANSIENT VOLTAGE RUGGEDNESS

Each ACS402 switch is able to safely withstand the AC line transient voltages either by clamping the low energy spikes or by breaking over under high energy shocks.

The test circuit in Figure 3 is representative of the final ACS™ application and is also used to stress the ACS™ switch according to the IEC61000-4-5 standard conditions. Thanks to the load, the ACS™ switch withstands the voltage spikes up to 2 kV above the peak line voltage. It will break over safely even on resistive load where the turn-on current rise is high as shown in Figure 4. Such non repetitive test can be done 10 times on each AC line voltage polarity.

Fig 3: Overvoltage ruggedness test circuit for resistive and inductive loads according to IEC61000-4-5 standard.
 $R = 150\Omega$, $L = 5\mu\text{H}$, $V_{PP} = 2\text{kV}$.

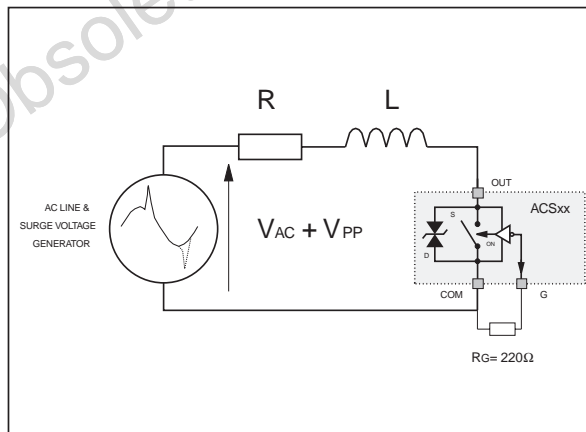

Fig 4: Current and voltage of the ACS™ during IEC61000-4-5 standard test with a $150\Omega - 10\mu\text{H}$ load & $V_{PP} = 2\text{kV}$.

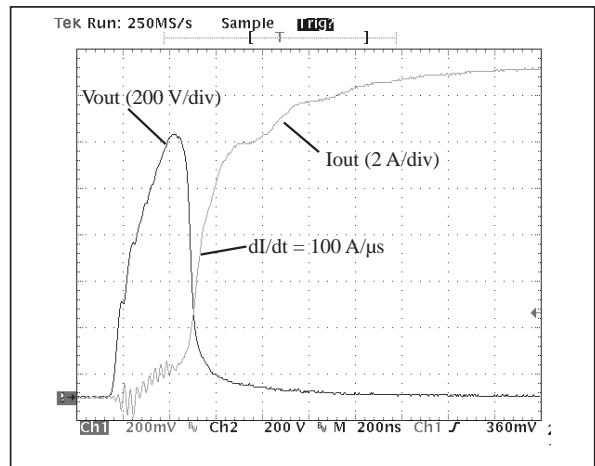

Fig. 5: Maximum power dissipation versus RMS on-state current (per switch).

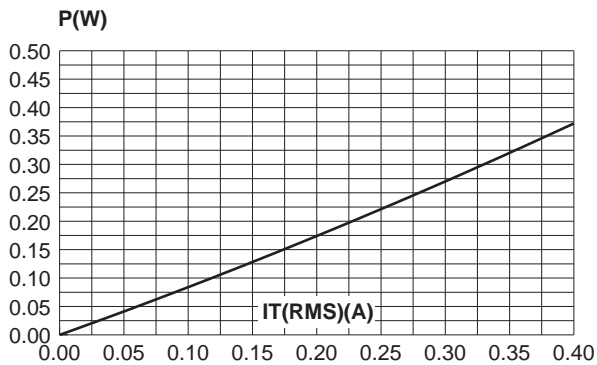

Fig. 6: RMS on-state current versus ambient temperature.

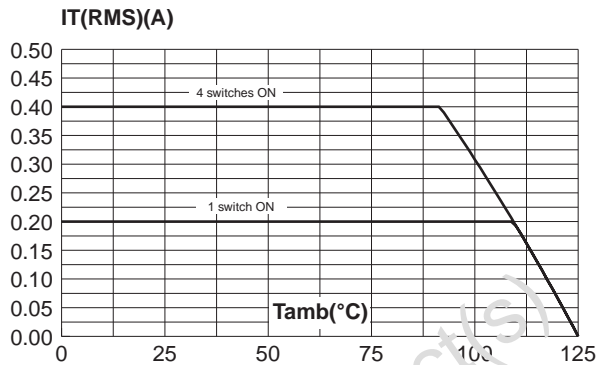

Fig. 7: Relative variation of thermal impedance junction to ambient versus pulse duration (device mounted on printed circuit board FR4, e(Cu) = 35µm)

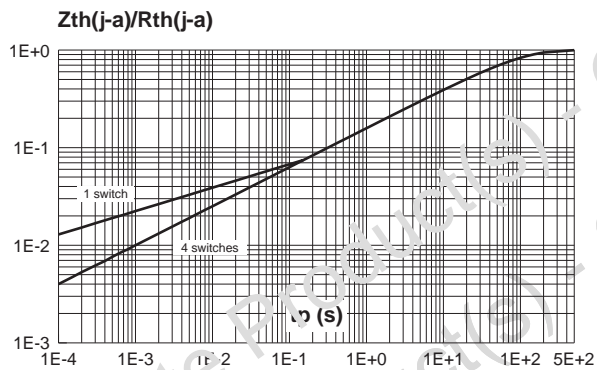

Fig. 8: Relative variation of gate trigger current versus junction temperature.

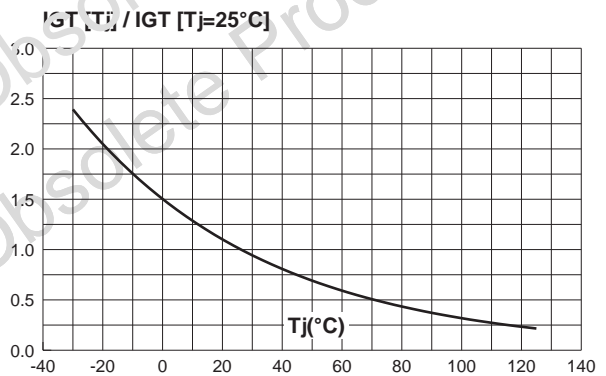

Fig. 9: Relative variation of holding and latching current versus junction temperature.

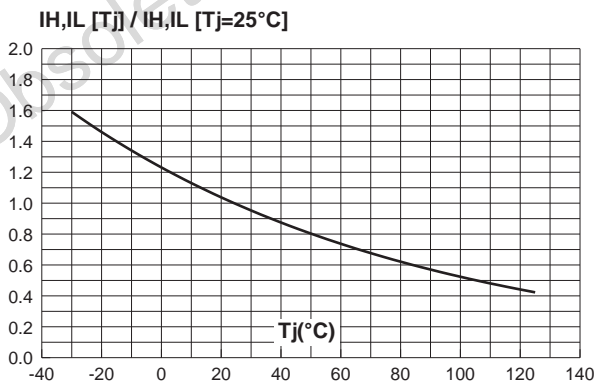

Fig. 10: Surge peak on-state current versus number of cycles.

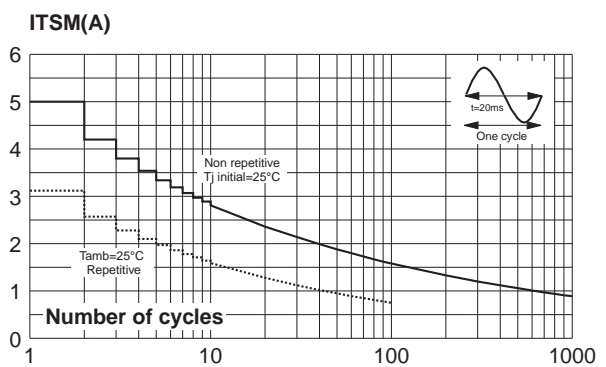

Fig. 11: Non-repetitive surge peak on-state current for a sinusoidal pulse with width $t_p < 10\text{ms}$, and corresponding value of I^2t .

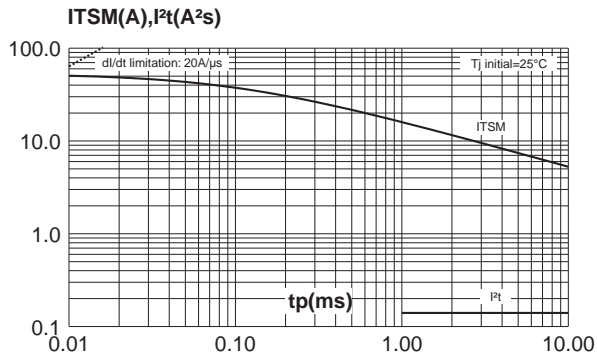

Fig. 12: On-state characteristics (maximum values).

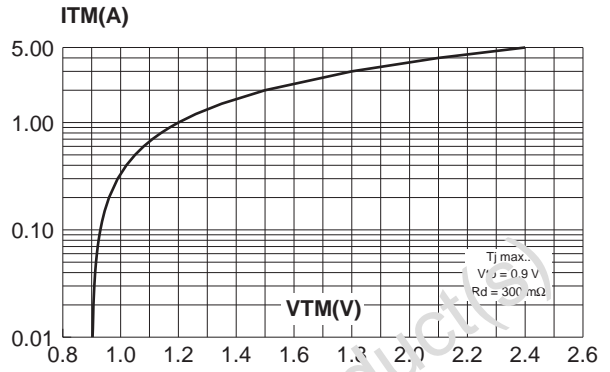
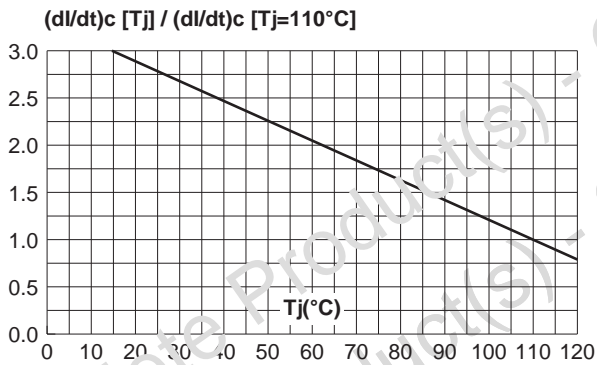
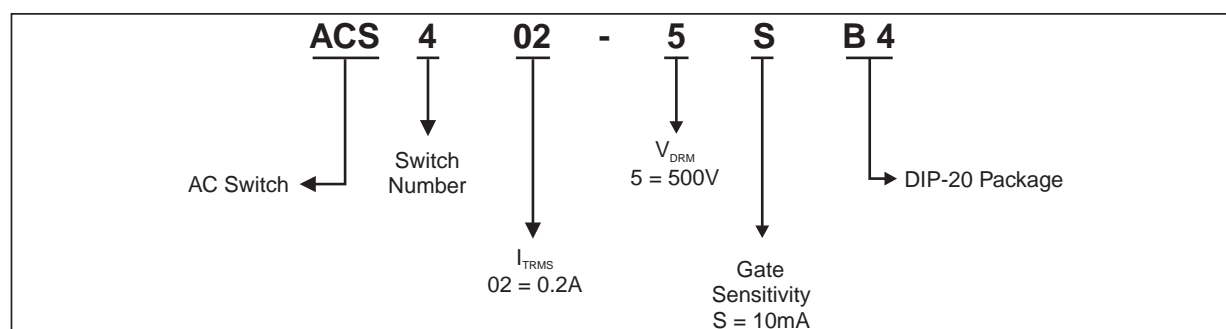

Fig. 13: Relative variation of critical $(di/dt)_c$ versus junction temperature.



Obsolete Product(s)
Obsolete Product(s)

ORDERING INFORMATION



PACKAGE MECHANICAL DATA

DIP-20

REF.	DIMENSIONS					
	Millimetres			Inches		
	Min.	Typ.	Max.	Min.	Typ.	Max.
a1	0.508			0.020		
B	1.30		1.65	0.055		0.065
b		0.45			0.018	
b1		0.25			0.010	
D			25.4			1.000
E		8.5			0.335	
e		2.54			0.100	
e3		22.86			0.900	
F			7.1			0.279
I			3.93			0.155
L		3.3			0.130	
Z			1.34			0.053

OTHER INFORMATION

Ordering type	Marking	Package	Weight	Base qty	Delivery mode
ACS402-5SB4	ACS4025	DIP-20	1.4 g.	19	Tube

- Epoxy meets UL94,V0

ASD and ACS are a trademarks of STMicroelectronics .

Information furnished is believed to be accurate and reliable. However, STMicroelectronics assumes no responsibility for the consequences of use of such information nor for any infringement of patents or other rights of third parties which may result from its use. No license is granted by implication or otherwise under any patent or patent rights of STMicroelectronics. Specifications mentioned in this publication are subject to change without notice. This publication supersedes and replaces all information previously supplied. STMicroelectronics products are not authorized for use as critical components in life support devices or systems without express written approval of STMicroelectronics.

The ST logo is a registered trademark of STMicroelectronics

© 2001 STMicroelectronics - Printed in Italy - All rights reserved.

STMicroelectronics GROUP OF COMPANIES



Australia - Brazil - China - Finland - France - Germany - Hong Kong - India - Italy - Japan - Malaysia
Malta - Morocco - Singapore - Spain - Sweden - Switzerland - United Kingdom - U.S.A.

<http://www.st.com>



Looking for pricing, stock, or lifecycle information?

Click below to explore more details on WIN SOURCE:

-  [View ACS4025S](#) on WIN SOURCE
-  [STMicroelectronics](#) Information

Optimize Your Supply Chain with WIN SOURCE Solutions

-  Global Sourcing Solution
-  Obsolete Management
-  Cost Control Management
-  Shortage Management
-  Alternative Solution
-  Excess Inventory Management