



**THE DATASHEET OF
DLP3V3DTZ-7**





General Descriptions

- This Transient Voltage Suppressor (TVS) diode is designed for dual unidirectional or single bidirectional protection for data lines, components or circuits from damage due to electrostatic discharge (ESD), cable discharge events (CDE) and lightning (see IPPM below). It offers high ESD capability, low reverse leakage, low junction capacitance and low clamping voltage over range of temperature. They are suitable for computers, communication systems, hand held portables, high density PC boards and peripherals.



Features

- 372 Watts Peak Pulse Power ($t_p=8/20 \mu\text{s}$)
- AEC-Q101 (Human Body Model- 8kV, Machine Model-400V) and 25 kV(air)/ 8 kV(contact) as per IEC61000-4-2(ESD)
- Dual Unidirectional and Single Bidirectional Configuration
- Lead Free By Design/ROHS Compliant (Note 2)**
- "Green" Device (Note 3 & 4)**
- Surface Mount Package Suited for Automated Assembly

Mechanical Data

- Case: SOT-23
- Case Material: "Green" Molding Compound (Molded Plastic). UL Flammability Classification Rating 94V-0
- Moisture Sensitivity: Level 1 per J-STD-020
- Terminal Connections: See Fig. 1
- Terminals: Finish - Matte Tin annealed over Alloy 42 leadframe. Solderable per MIL-STD-202, Method 208
- Marking & Type Code Information: See Page 6
- Ordering Information: See Page 6
- Weight: 0.008 grams (approximate)

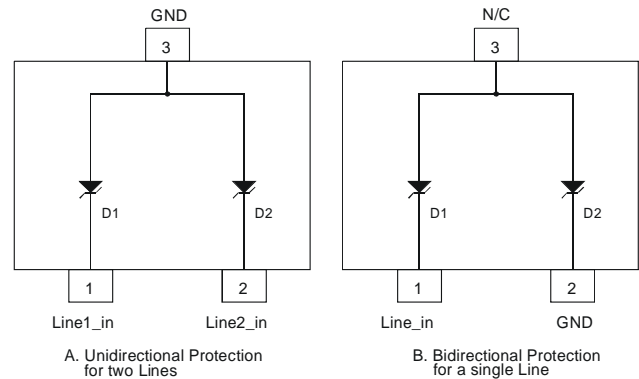

Fig. 1: Schematic and Pin Configuration

Absolute Maximum Ratings

@ $T_A = 25^\circ\text{C}$ unless otherwise specified

Characteristic	Symbol	Value	Unit
Peak Pulse Power ($t_p=8/20\mu\text{s}$)	Unidirectional	372	W
	Bidirectional	145	
Continuous Power Dissipation (Note1)	P_D	300	mW
Maximum Peak Pulse Current ($t_p=8/20 \mu\text{s}$)	Unidirectional	40	A
	Bidirectional	15	
Forward Surge Current (8.3 ms half sine-wave)	I_{FSM}	10.5	A
ESD per IEC 6100--4-2(air)	V_{pp}	± 25	kV
ESD per IEC 6100--4-2(contact)		± 8	

Thermal Characteristics

Characteristic	Symbol	Value	Unit
Operating and Storage Junction Temperature Range	T_j, T_{stg}	-55 to +150	$^\circ\text{C}$
Thermal Resistance, Junction to Ambient Air (Note1)	$R_{\theta JA}$	420	$^\circ\text{C/W}$

- Notes:
- Device mounted on FR-4 PCB, 1 inch x 0.85 inch x 0.062 inch; as per Diodes Inc. suggested pad layout document AP02001 on our website at <http://www.diodes.com/datasheets/ap02001.pdf>.
 - No purposefully added lead.
 - Diodes Inc.'s "Green" policy can be found on our website at http://www.diodes.com/products/lead_free/index.php.
 - Product manufactured with Date Code 0627 (week 27, 2006) and newer are built with Green Molding Compound. Product manufactured prior to Date Code 0627 are built with Non-Green Molding Compound and may contain Halogens or Sb2O3 Fire Retardants.

Electrical Characteristics

@T_A = 25°C unless otherwise specified

Characteristic	Symbol	Min	Typ	Max	Unit	Test Condition	
Rated Reverse Standoff Voltage	V _{RWM}	—	—	3.3	V	Pin 1 to 3 or Pin 2 to 3	
Breakdown Voltage	V _{BR}	4.5	—	—	V	Pin 1 to 3 or Pin 2 to 3 @ I _T = 1mA	
Forward Voltage	V _F	—	0.8	—	V	Pin 3 to 1 or Pin 3 to 2, I _F = 10mA	
Reverse Leakage Current @V _{RWM}	I _R	—	—	0.095	mA	Pin 1 to 3 or Pin 2 to 3	
Clamping Voltage (Note 5)	Unidirectional	—	—	6.0	V	I _{pp} = 1A (Pin 1 to 3 or Pin 2 to 3)	
	Bidirectional	—	—	7.0	V	I _{pp} = 1A (Pin 1 to 2 or Pin 2 to 1, Pin 3 = nc)	
	Unidirectional	—	—	9.3	V	I _{pp} = 40A (Pin 1 to 3 or Pin 2 to 3)	
	Bidirectional	—	—	9.666	V	I _{pp} = 15A (Pin 1 to 2 or Pin 2 to 1, Pin 3 = nc)	
Junction Capacitance	Unidirectional	—	—	420	pF	V _R = 0V, f = 1 MHz	
	Bidirectional	—	—	210	pF		
	Unidirectional	—	—	230	pF	V _R = 3.3V, f = 1 MHz	
	Bidirectional	—	—	115	pF		
Dynamic Resistance @ I _{pp} (large signal)	Unidirectional	R _d	—	0.115	Ω	I _{pp} = 40A, V _c = 9.3V, V _{BR} = 4.5V (Pin 1 to 3 or 2 to 3)	
Dynamic Impedance (small signal)	Unidirectional	Z _{zt}	—	380	—	Ω	I _R = 1 mA, f = 1 KHz (Pin 1 to 3 or 2 to 3)
			—	47	—	Ω	I _R = 5 mA, f = 1 KHz (Pin 1 to 3 or 2 to 3)
Temperature Coefficient	Unidirectional	θ _{vz}	—	-1.07	—	mV/°C I _R = 5 mA (Pin 1 to 3 or 2 to 3)	

Notes: 5. Clamping voltage value is based on a t_p = 8/20 μs peak pulse current (I_{pp}) waveform.

Typical Characteristics

@T_{amb} = 25°C unless otherwise specified

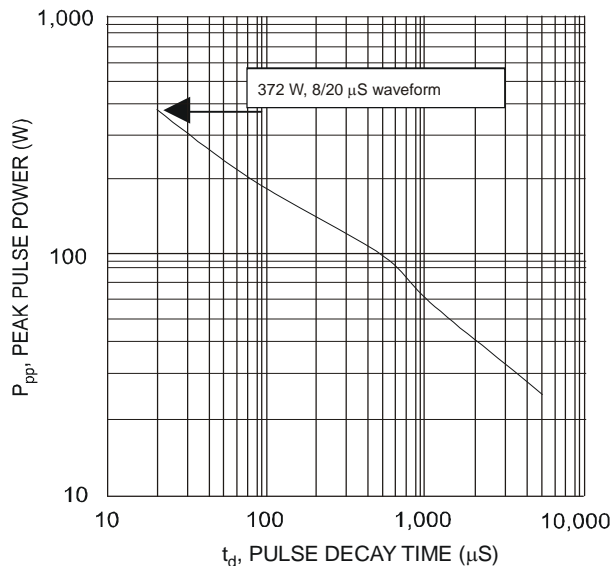

Fig. 2 Unidirectional Non-Repetitive Peak Pulse Power vs. Pulse Duration or Pulse Width

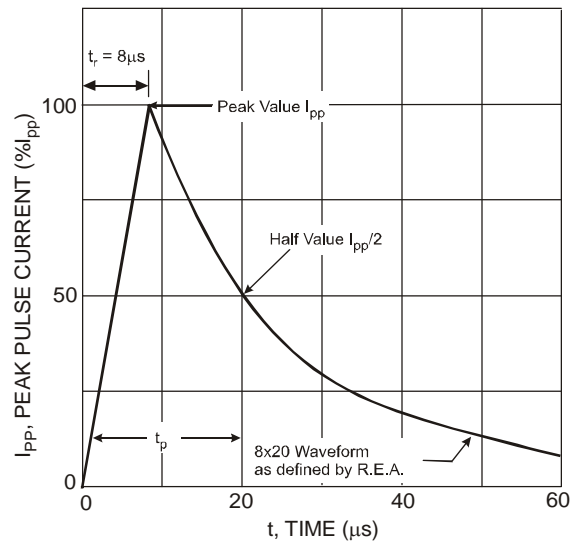

Fig. 3 Pulse Waveform

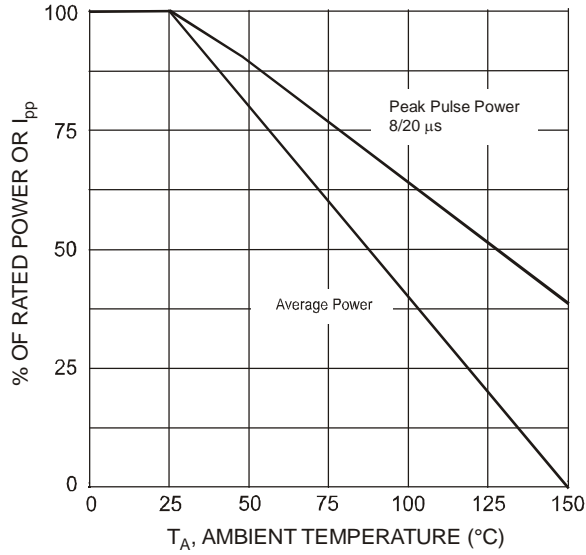

Fig. 4 Power Derating Curve

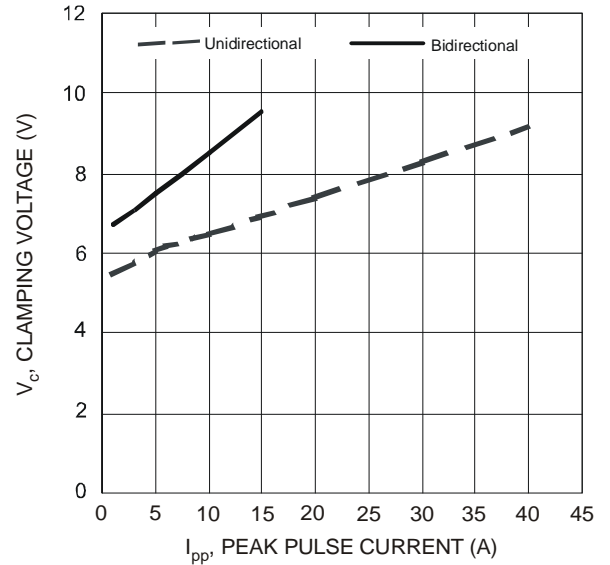

Fig. 5 Clamping Voltage vs. Peak Pulse Current

Single TVS Diode Characteristics:

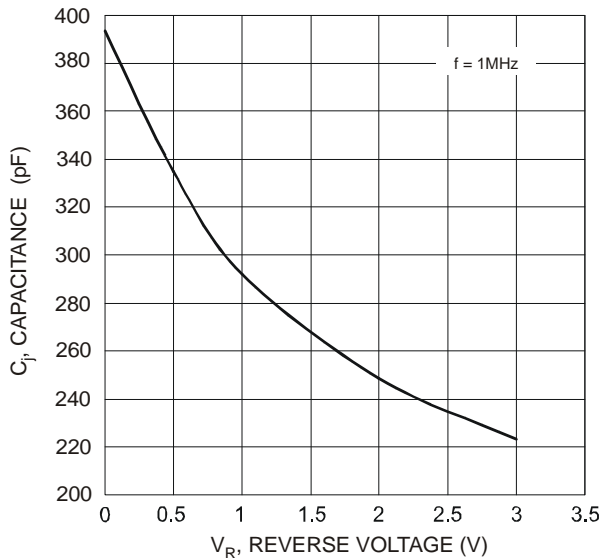

Fig. 6 Junction Capacitance vs. Reverse Voltage

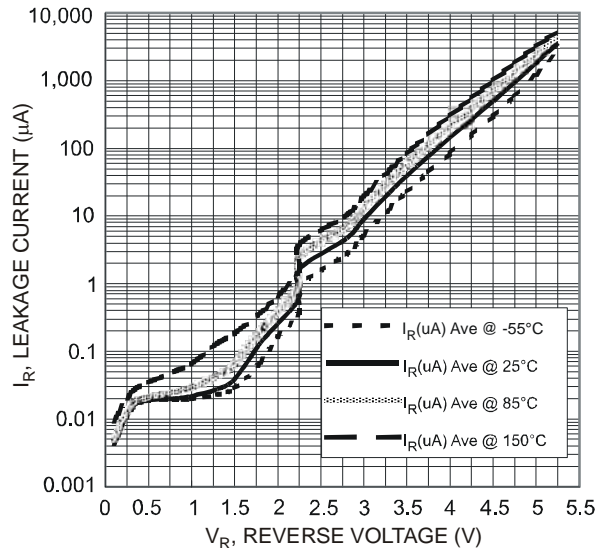

Fig. 7 Leakage Current vs. Reverse Voltage

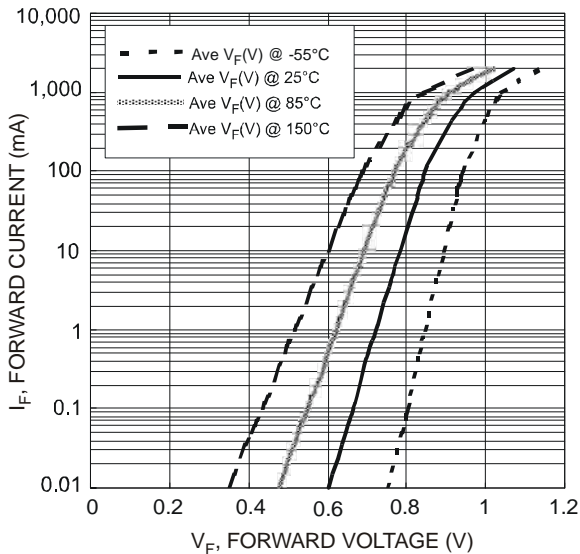

Fig. 8 Typical Forward Characteristic

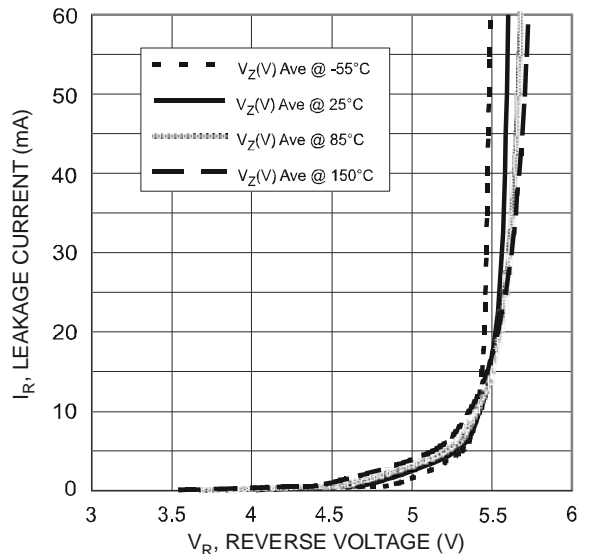

Fig. 9 Typical Reverse Characteristic

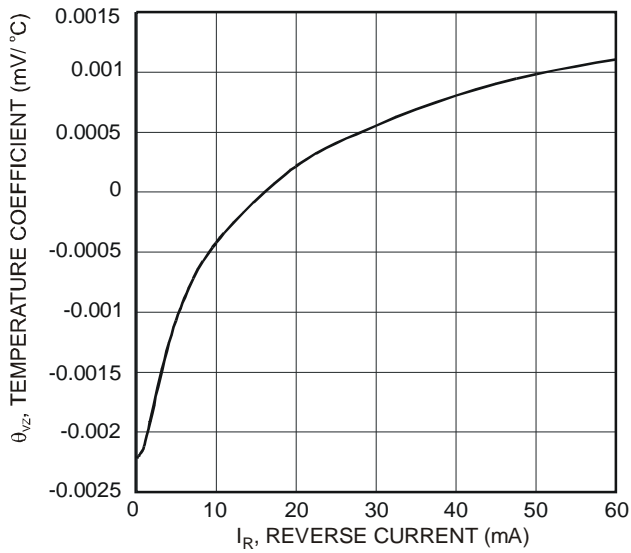

Fig. 10 Temperature Coefficient vs. Reverse Current

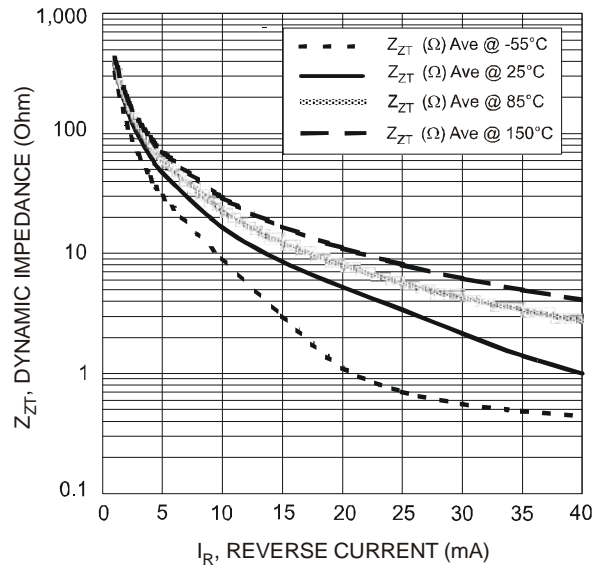

Fig. 11 Dynamic Impedance vs. Reverse Current (Small Signal)

Circuit Diagram

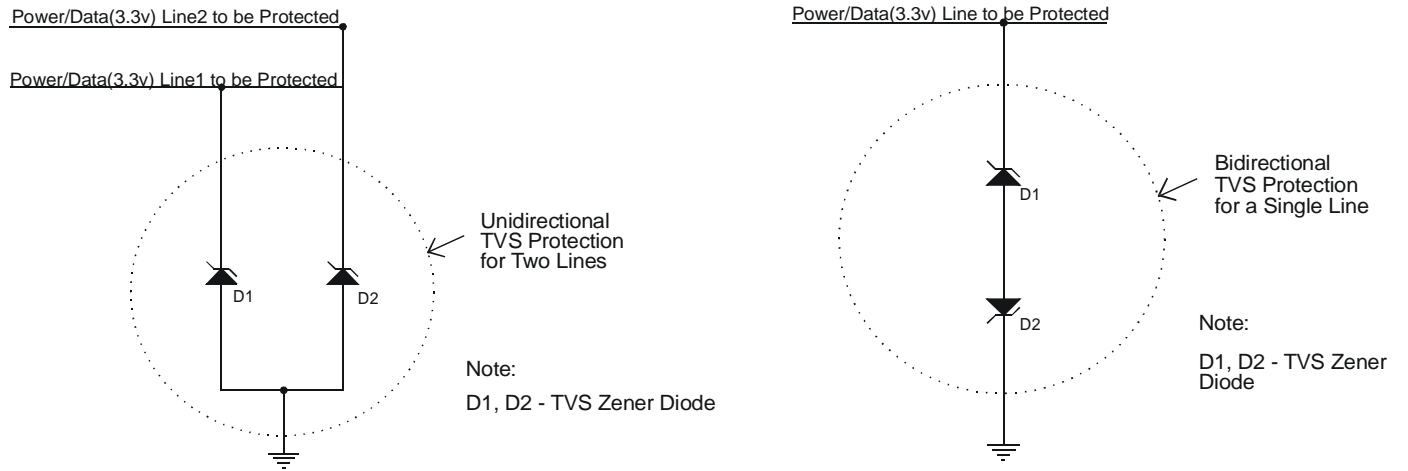

Fig. 12

Typical Application Circuit

Unidirectional Protection for Two 3.3V Dataline

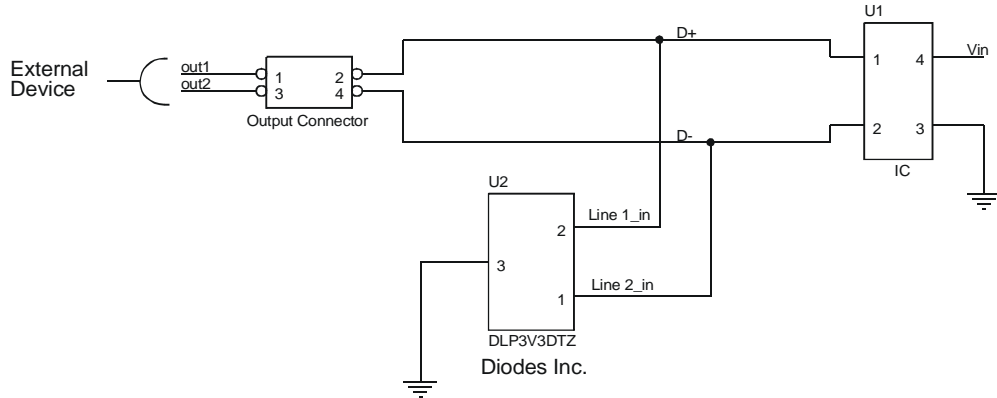

Fig. 13

Bidirectional Protection for 3.3v Power Supply Bus

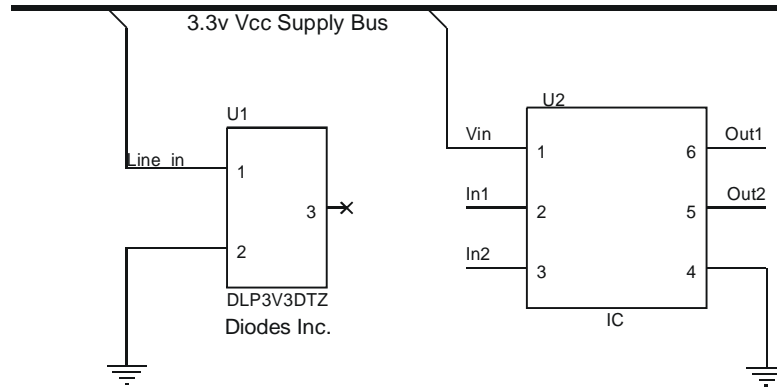

Fig. 14

Application Information

Protection from ESD

It is a fact that ESD is the primary cause of failure in electronic systems. Transient Voltage Suppressors(TVS) are an ideal choice for using as ESD protection devices. They have the capability to clamp the incoming transient to such a low level that the damage to the circuit beyond the device is prevented. Surface mount TVS are the best choice for minimum lead inductance. DLP3V3DTZ is designed to be used as two unidirectional or single bidirectional protection device in a circuit. They serve as parallel protection elements, connected between the signal line to ground. It will present a high impedance to the protected line up to 3.3 volts. As the transient rises above the operating voltage which is the breakdown voltage of the device, the TVS diode becomes a low impedance path diverting the transient current to ground.

Dynamic Resistance to Calculate Clamping Voltage

At times PCB designers need to calculate the clamping voltage V_{CL} . For this reason the dynamic resistance in addition to the typical parameters is listed here. The voltage across the protected circuitry can be calculated as following:

$$V_{CL} = V_{BR} + R_d * I_{pp} \quad (\text{also } V_{CL} = V_z + R_d * I_{pp} \dots \text{for accuracy})$$

e.g. If $I_{pp} = 1A$, $V_{CL} = V_z + R_d * I_{pp} = 5.6V$ (from fig. 9) + $1A * 0.115 \text{ Ohm} = (5.6 + 0.115)V = 5.715V$ (close to actual measured Value)
 Where I_{pp} is the peak current through the TVS Diode. The short duration of the ESD has led us to a widely adapted classical test wave, 8/20 μS and 10/1000 μS surges. Since Z_{zt} remains stable for a surge duration less than 20 μS , the 2.5 μS rectangular surge is sufficient for use.

Peak Pulse Power Calculation

The following relation fits well for pulse width less than 10 mS.

$$P_{pp} = K (td)^{-0.5}$$

e.g. $P_{pp} = 372 \text{ watts}$ for pulse width(td) of 20 μS , then $372 \text{ watts} = K (20)^{-0.5}$ and $K = 372 / (20)^{-0.5} = 372 * \sqrt{20} = 1663.63$

Now, P_{pp} when $td = 50 \mu S$: $P_{pp} = 1663.63 (50)^{-0.5} = 1663.63 / (\sqrt{50}) = 235.27 \text{ watts}$ (close to measured value see fig. 2)

Tips for Circuit Board Layout

Correct layout of the circuit board plays a critical role in preventing ESD induced failures. Some of useful guidelines are given below:

- Trace length between the TVS diode and the circuit or line to be protected should be kept to a minimum.
- Always place a TVS diode as close as possible to the input terminals or connectors if one is required.
- Try to avoid or minimize power and ground loops or any other conductive loops.
- Try to use ground planes whenever feasible rather than a simple ground trace.
- The path to ground for the ESD transient return should be as short as possible.

Ordering Information (Note 4 & 6)

Device	Packaging	Shipping
DLP3V3DTZ-7	SOT-23	3000/Tape & Reel

Notes: 6. For packaging details, go to our website at <http://www.diodes.com/datasheets/ap02007.pdf>.

Marking Information

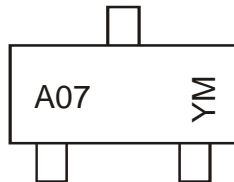

A07 = Product Type Marking Code
 YM = Date Code Marking
 Y = Year (e.g., T = 2006)
 M = Month (e.g., 1 = January)

Date Code Key

Year	2006	2007	2008	2009	2010	2011	2012
Code	T	U	V	W	X	Y	Z

Month	Jan	Feb	Mar	Apr	May	Jun	Jul	Aug	Sep	Oct	Nov	Dec
Code	1	2	3	4	5	6	7	8	9	O	N	D

Package Outline Dimensions

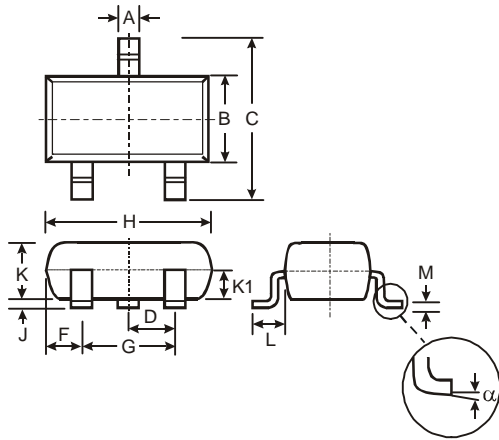

SOT-23			
Dim	Min	Max	Typ
A	0.37	0.51	0.40
B	1.20	1.40	1.30
C	2.30	2.50	2.40
D	0.89	1.03	0.915
F	0.45	0.60	0.535
G	1.78	2.05	1.83
H	2.80	3.00	2.90
J	0.013	0.10	0.05
K	0.903	1.10	1.00
K1	-	-	0.400
L	0.45	0.61	0.55
M	0.085	0.18	0.11
α	0°	8°	-
All Dimensions in mm			

Suggested Pad Layout

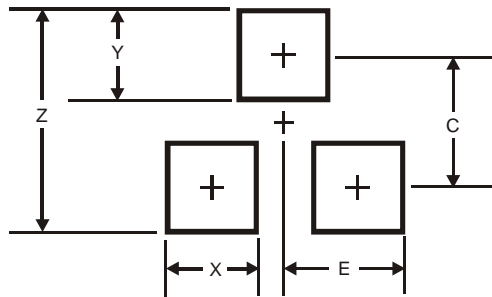

Dimensions	Value (in mm)
Z	2.9
X	0.8
Y	0.9
C	2.0
E	1.35

IMPORTANT NOTICE

DIODES INCORPORATED MAKES NO WARRANTY OF ANY KIND, EXPRESS OR IMPLIED, WITH REGARDS TO THIS DOCUMENT, INCLUDING, BUT NOT LIMITED TO, THE IMPLIED WARRANTIES OF MERCHANTABILITY AND FITNESS FOR A PARTICULAR PURPOSE (AND THEIR EQUIVALENTS UNDER THE LAWS OF ANY JURISDICTION).

Diodes Incorporated and its subsidiaries reserve the right to make modifications, enhancements, improvements, corrections or other changes without further notice to this document and any product described herein. Diodes Incorporated does not assume any liability arising out of the application or use of this document or any product described herein; neither does Diodes Incorporated convey any license under its patent or trademark rights, nor the rights of others. Any Customer or user of this document or products described herein in such applications shall assume all risks of such use and will agree to hold Diodes Incorporated and all the companies whose products are represented on Diodes Incorporated website, harmless against all damages.

Diodes Incorporated does not warrant or accept any liability whatsoever in respect of any products purchased through unauthorized sales channel. Should Customers purchase or use Diodes Incorporated products for any unintended or unauthorized application, Customers shall indemnify and hold Diodes Incorporated and its representatives harmless against all claims, damages, expenses, and attorney fees arising out of, directly or indirectly, any claim of personal injury or death associated with such unintended or unauthorized application.

Products described herein may be covered by one or more United States, international or foreign patents pending. Product names and markings noted herein may also be covered by one or more United States, international or foreign trademarks.

LIFE SUPPORT

Diodes Incorporated products are specifically not authorized for use as critical components in life support devices or systems without the express written approval of the Chief Executive Officer of Diodes Incorporated. As used herein:

A. Life support devices or systems are devices or systems which:

1. are intended to implant into the body, or
2. support or sustain life and whose failure to perform when properly used in accordance with instructions for use provided in the labeling can be reasonably expected to result in significant injury to the user.

B. A critical component is any component in a life support device or system whose failure to perform can be reasonably expected to cause the failure of the life support device or to affect its safety or effectiveness.

Customers represent that they have all necessary expertise in the safety and regulatory ramifications of their life support devices or systems, and acknowledge and agree that they are solely responsible for all legal, regulatory and safety-related requirements concerning their products and any use of Diodes Incorporated products in such safety-critical, life support devices or systems, notwithstanding any devices- or systems-related information or support that may be provided by Diodes Incorporated. Further, Customers must fully indemnify Diodes Incorporated and its representatives against any damages arising out of the use of Diodes Incorporated products in such safety-critical, life support devices or systems.

Copyright © 2009, Diodes Incorporated

www.diodes.com

Looking for pricing, stock, or lifecycle information?

Click below to explore more details on WIN SOURCE:

-  [View DLP3V3DTZ-7 on WIN SOURCE](#)
-  [Diodes Incorporated Information](#)

Optimize Your Supply Chain with WIN SOURCE Solutions

-  Global Sourcing Solution
-  Obsolete Management
-  Cost Control Management
-  Shortage Management
-  Alternative Solution
-  Excess Inventory Management