



**THE DATASHEET OF
LIF-UC120-SWG36ITR50**





Lattice USB Type-C Solution Data Sheet

DS1052 Version 1.4, August 2016

General Description

The USB Type-C receptacle, plug and cable provide a smaller, thinner and more robust alternative to existing USB interconnects. The Lattice USB Type-C solution targets its use in a variety of platforms ranging from notebooks, PCs, Monitors, down to tablets and smart phones. These solutions are also implemented in Docking Stations, USB chargers and cables where cable detect (CD) electronic intelligence and power delivery (PD) protocols are implemented.

The Lattice solution is designed to support USB Type-C cable and Connector and USB Power Delivery specifications with programmable flexibility to support the new and evolving specifications as well as the various levels of complexities required by the end system in a cost effective manner.

Features

- **Two solutions cover majority of USB Type-C Power Delivery (PD) and Cable Detect (CD) Applications:**
 - CD/PD for Charger
 - CD/PD for hosts/devices
- **Logic Based PHY Provides Fast Deterministic Response and Low Power**
 - Typical Solution Power 7 mW
- **Standby Power less than 100 uW**
- **Flexible 8-bit uC Policy Engine Enables Easy Modifications**
- **Supports Fast Development**
 - Industry Proven Solutions Reduce Design Risk
 - Schematics and BOMS available to minimize system design effort
- **Wide Range of Packages to Match PCB Technology**
 - 48 QFN
 - 81 ucBGA
- **Ultra-Small Form Factor**
 - As small as 2.078 mm x 2.078 mm
- **USB Type-C PHY**
- **USB Type-C Cable Detect (CD) support per USB Cable and Connector Specification v1.0**
- **USB Power Delivery (PD) support per Power Delivery Specification v2.0**
 - IO capability to drive LED indicator

Table 1-1. USB Type-C Device Table

Solution	Package, Ball Pitch, Dimension	Typical End Equipment	OPN
CD/PD for Charger	48 QFN, 0.50 mm, 7.00 mm x 7.00 mm	Charger	LIF-UC110-SG48I
CD/PD for Hosts/Devices	81 ucBGA, 0.40 mm, 4.00 mm x 4.00 mm	Tablet	LIF-UC140-CM81I

Architecture Overview

Figure 2-1. High-level Functional Block for USB Type-C Physical Layer and Power Detect Protocol

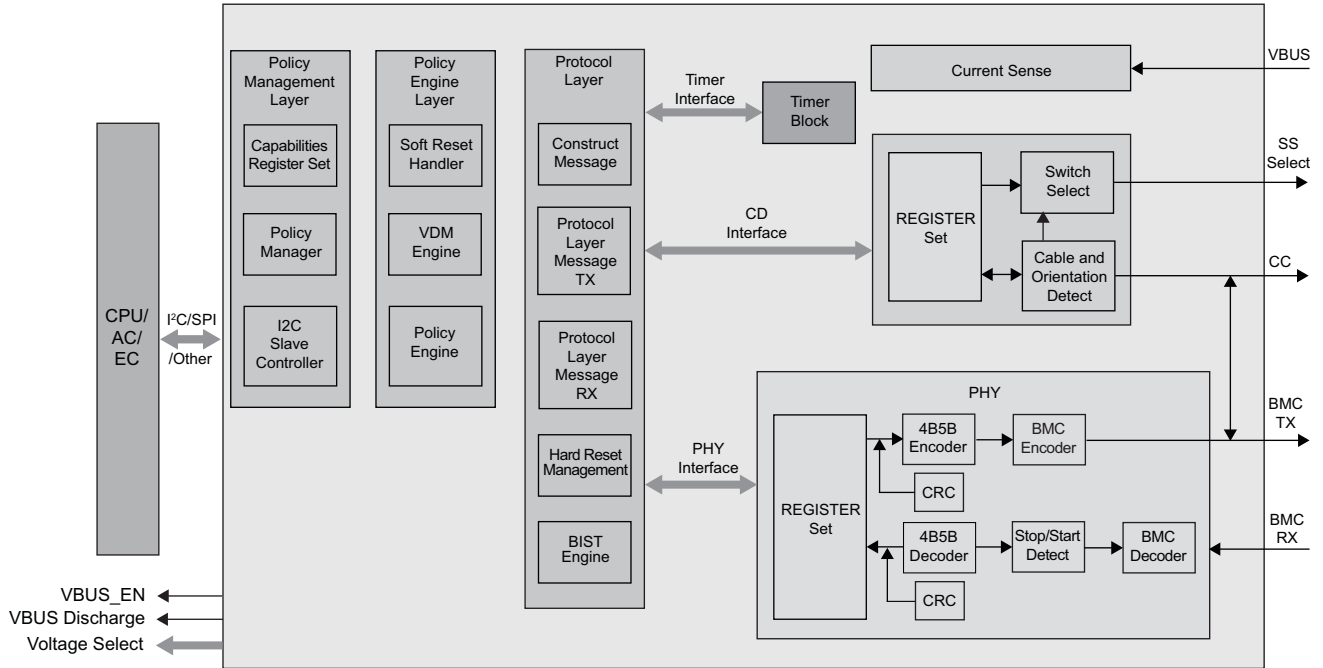

USB CD/PD Charger Solution (Captive Cable)

Block Diagram

Figure 2-2. USB CD/PD Charger Solution (Captive Cable) Block Diagram

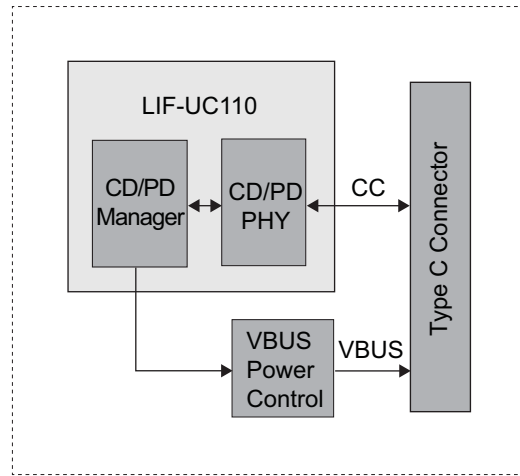

CD = Cable Detect
PD = Power Delivery

Features Supported in Schematics

- Downstream Facing Port (DFP)
- USB Power Delivery Communication between Port partners
- Takes advantage of captive cable to minimize component count

Table 2-1. USB CD/PD Mobile System Solution (Captive Cable) BOM

Item	Quantity	Reference	Part	DESCRIPTION
1	3	C1, C13, C14	0.047 uF	CAP CER 0.047 uf 10 V 10% X5R 0402
2	3	C2, C6, C12	10 uF	CAP CER 10 uf 10 V 10% X5R 0805
3	6	C4, C5, C7, C3, C8, C11	100 nF	CAP CER 100 nf 10 V 10% X5R 0402
4	1	C9	4.7 nF	CAP CER 3300 pF 10 V 5% U2J 0402
5	1	C10	330 pF	CAP CER 3300 pF 16 V 10% X7R 0402
6	1	D1	CDBU0520	DIODE SCHOTTKY 20 V 500 MA 0603
7	1	Q1	P-Channel	MOSFET P-CH 20 V 6 A SOT-23
8	1	Q3	N-Channel	MOSFET N-CH 20 V 6.3 A SOT-23
9	2	Q2, Q6	N-Channel	MOSFET N-CH 30 V 0.85 A SOT23
10	3	R4, R15	1K	RES 1 kOhm 1/16 W 5% 0402
11	2	R2, R5, R18	510K	RES 510 kOhm 1/16 W 5% 0402
12	1	R8	100R	RES SMD 100 Ohm 1% 1/16 W 0402
13	3	R6, R16, R17	4K7	RES 150 Ohm 1/16 W 1% 0402 SMD
14	1	R11	100R	RES 100 Ohm 1/16 W 5% 0402
15	1	R9	42.2R	RES SMD 42.2 Ohm 1% 1/16 W 0402
16	1	R3	100R	RES SMD 100 Ohm 1% 1 W 2512
17	1	R7	75K	RES SMD 75 kOhm 5% 1/16 W 0402
18	1	R1	10m	RES 0.01 Ohm 1/2 W 1% 1206
19	1	U1	LIF-UC	LIF-UC 48-Pin Device

Table 2-2. USB CD/PD Mobile System Solution (Captive Cable) BOM Count^{1, 2}

Item	Component	Count
1	Cap	14
2	FET	1
3	Resistor	11
4	Lattice LIF-UC	1

1. VBUS control section components are not included in the BOM count.
2. Diode D1 is not included in the BOM count. It is required only during onboard NVCM programming.

USB CD/PD Charger Solution (Non-Captive Cable)

Block Diagram

Figure 2-4. USB CD/PD Charger Solution (Non-Captive Cable) Block Diagram

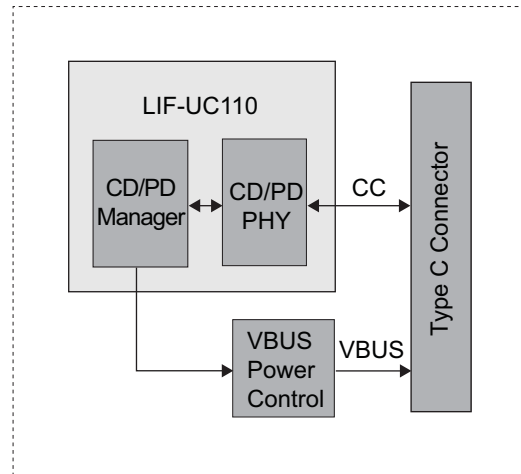

CD = Cable Detect
PD = Power Delivery

Features Supported in Schematics

- DFP
- USB Power Delivery Communication between Port partners
- Provides cable flip support needed in chargers with receptacles

BOM
Table 2-3. USB CD/PD Charger Solution (Non-Captive Cable) BOM

Item	Quantity	Reference	Part	DESCRIPTION
1	4	C1, C15, C16, C18	0.047 uF	CAP CER 0.047 uf 10 V 10% X5R 0402
2	3	C2, C6, C12	10 uF	CAP CER 10 uf 10 V 10% X5R 0805
3	6	C4, C5, C7, C3, C8, C11	100 nF	CAP CER 100 nf 10 V 10% X5R 0402
4	2	C9, C17	4.7 nF	CAP CER 4700 pF 10.V 5% U2J 0402
5	2	C10, C14	330 pF	CAP CER 330 pF 16 V 10% X7R 0402
6	1	D1	CDBU0520	DIODE SCHOTTKY 20 V 500 MA
7	1	Q1	P-Channel	MOSFET P-CH 20 V 6 A SOT-23
8	1	Q3	N-Channel	MOSFET N-CH 20 V 6.3 A SOT-23
9	3	Q2, Q6, Q7	N-Channel	MOSFET N-CH 30 V 0.85 A SOT23
10	4	R4, R19, R20	1K	RES 1K Ohm 1/16 W 5% 0402
11	2	R2, R5, R21	510K	RES 510K Ohm 1/16 W 5% 0402
12	6	R6, R12, R18, R22, R23, R24	4K7	RES 4.7K Ohm 1/16 W 5% 0402
13	2	R8, R13	100R	RES SMD 100 Ohm 1% 1/16 W 0402
14	2	R9, R14	42.2R	RES SMD 42.2 Ohm 1% 1/16 W 0402
15	1	R11	100R	RES 100 Ohm 1/16 W 5% 0402
16	1	R3	100R	RES SMD 100 Ohm 1% 1 W 2512
17	1	R7	75K	RES SMD 75 kOhm 5% 1/16 W 0402
18	1	R1	10m	RES 0.01 Ohm 1/2 W 1% 1206
19	1	U1	LIF-UC	LIF-UC 48-Pin Device
20	1	U2	TS5A23159RSER	Switch Dual SPDT

BOM Count
Table 2-4. USB CD/PD Charger Solution (Non-Captive Cable) BOM Count^{1, 2}

Item	Component	Count
1	Cap	17
2	FET	2
3	Resistor	17
4	Lattice LIF-UC	1
5	Dual SPDT	1

1. VBUS control section components are not included in the BOM count.

2. Diode D1 is not included in the BOM count. It is required only during onboard NVCM programming.

CD/PD for Hosts/Devices

Block Diagram

Figure 2-6. CD/PD for Hosts/Devices Block Diagram

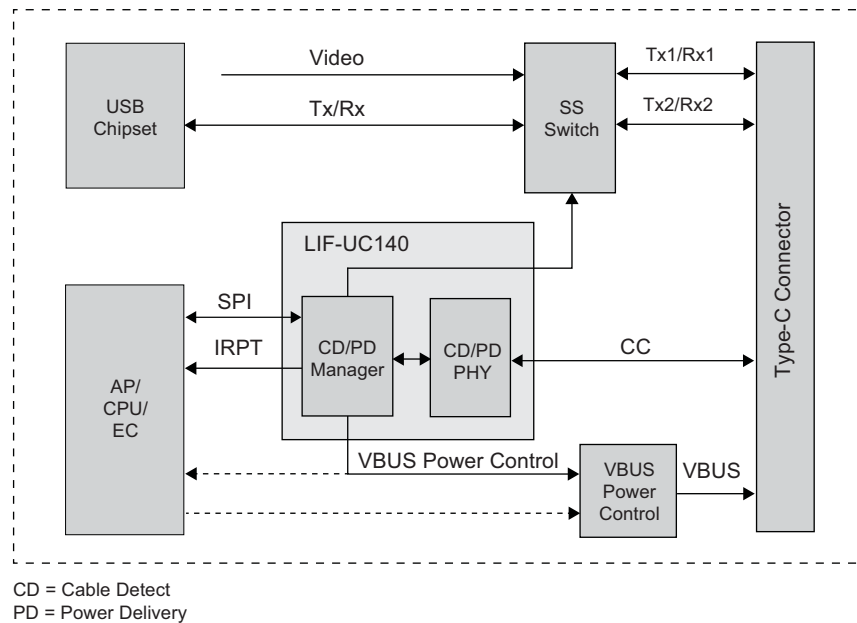

Features Supported in Schematics

- Dual Role Port (DRP)
- USB Power Delivery Communication between Port partners
- SS/HS switch control
- VBUS Source/Sink and Discharge Control signals
- Alternate mode support
- SPI Config interface is reused as SPI interface post configuration. SPI is used to interface PD to AP/Controller/Processor.

Schematics

Figure 2-7. CD/PD for Hosts/Devices Schematic Diagram

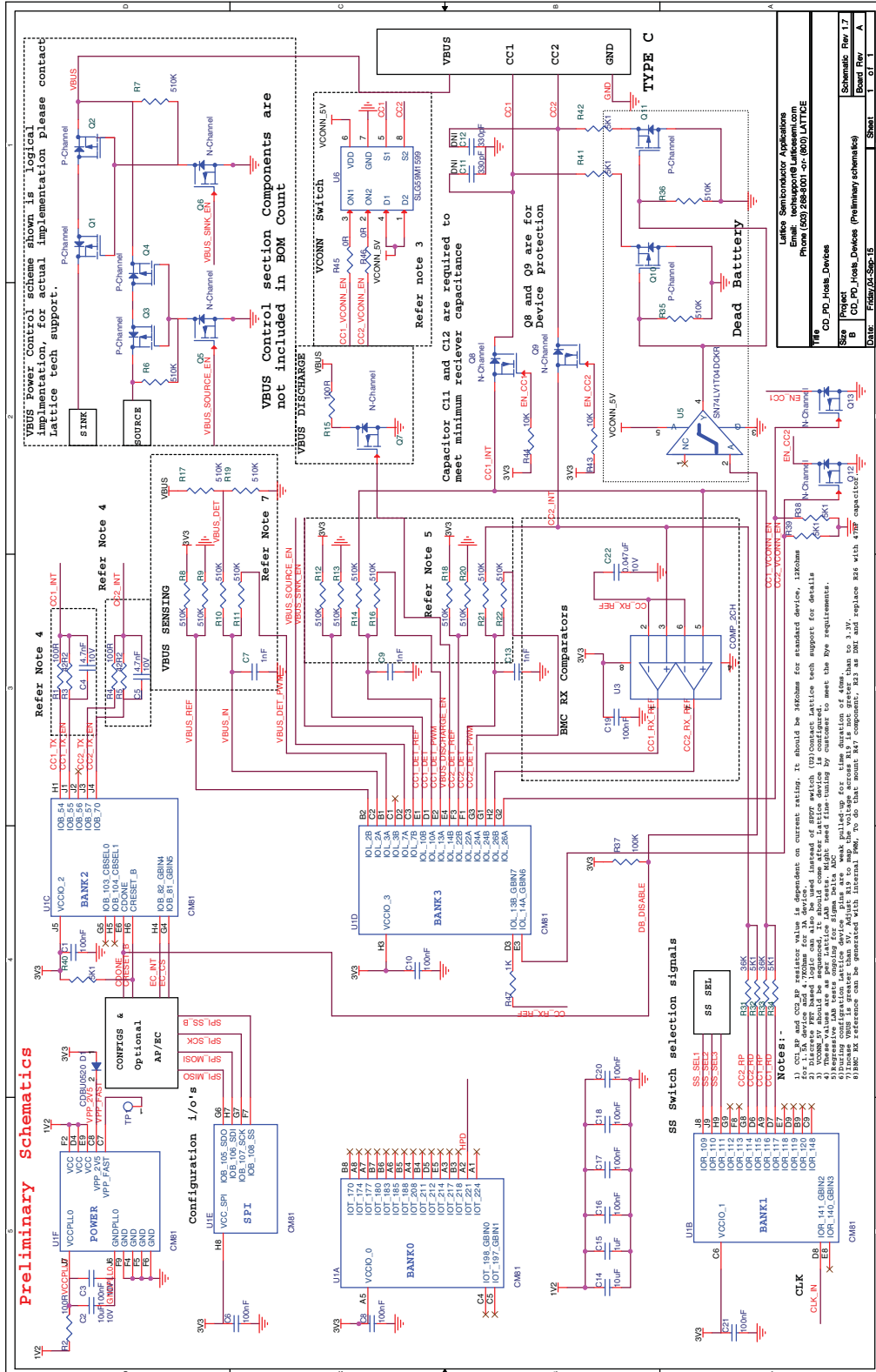

BOM
Table 2-5. CD/PD for Hosts/Devices BOM

Item	Quantity	Reference	Part	Description
1	11	C1,C3,C6,C8,C10,C16,C17,C18,C19,C20,C21	100 nF	CAP CER 100nf 10V 10% X5R 0402
2	2	C2,C14	10 uF	CAP CER 10uf 10V 10% X5R 0805
3	2	C4,C5	4.7 nF	CAP CER 4700PF 10V 5% U2J 0402
4	3	C7,C9,C13	1 nF	CAP CER 1000PF 10V 10% X5R 0402
5	2	C11,C12	330 pF	CAP CER 330PF 16V 10% X7R 0402
6	1	C15	1 uF	CAP CER 1uf 10V 10% X5R 0402
7	1	C22	0.047uF	CAP CER 0.047uf 10V 10% X5R 0402
8	1	D1	CDBU0520	DIODE SCHOTTKY 20V 500MA 0603
9	4	Q1,Q2,Q3,Q4	P-Channel	MOSFET P-CH 20V 6A SOT-23
10	6	Q5,Q6,Q8,Q9,Q12,Q13	N-Channel	MOSFET N-CH 30V 0.85A SOT23
11	1	Q7	N-Channel	MOSFET N-CH 20V 6.3A SOT-23
12	2	Q10,Q11	P-Channel	MOSFET P-CH 20V 760MA SOT-416
13	2	R1,R4	100R	RES SMD 100 OHM 1% 1/16W 0402
14	1	R2	100R	RES 100 OHM 1/16W 5% 0402
15	2	R3,R5	42R2	RES SMD 42.2 OHM 1% 1/16W 0402
16	18	R6,R7,R8,R9,R10,R11,R12,R13,R14,R16,R17,R18,R19,R20,R21,R22,R35,R36	510K	RES 510K OHM 1/16W 5% 0402
17	1	R15	100R	RES SMD 100 OHM 1% 1W 2512
18	2	R31,R33	36K	RES 36K OHM 1/16W 5% 0402
19	7	R32,R34,R38,R39,R40,R41,R42	5K1	RES 5.1K OHM 1/16W 5% 0402
20	1	R37	100K	RES 100K OHM 1/16W 5% 0402
21	2	R43,R44	10K	RES 10K OHM 1/16W 5% 0402
22	2	R45,R46	0R	RES 0.0 OHM 1/16W JUMP 0402
23	1	R47	1K	Thick Film Resistors - SMD 1/16watt 1.0Kohms 1%
24	1	U1	LIF-UC	LIF-UC 81-Pin Device
25	1	U3	COMP_2CH	Analog Comparators Dual,40ns,microPower RRI Comparator
26	1	U5	SN74LV1T04DCKR	IC BUFFER GATE SGL CMOS SC70-5
27	1	U6	SLG59M1599	Ultra-small Dual 40 mO 1.0 A GreenFET 3 Load Switch

BOM Count*Table 2-6. CD/PD for Hosts/Devices BOM Count^{1, 2}*

Item	Component	Count
1	CAP	22
2	FET	6
3	Resistor	36
4	Load Switch	1
5	Level Translator	1
6	Comparator	1
7	Lattice LIF-UC	1

1. VBUS control section components are not Included in the BOM count.

2. Diode D1 is not included in the BOM count. It is required only during onboard NVCM programming.

Absolute Maximum Ratings^{1, 2, 3}

Supply Voltage V_{CC}	-0.5 V to 1.42 V
Output Supply Voltage V_{CCIO}	-0.5 V to 3.60 V
NVCM Supply Voltage V_{PP_2V5}	-0.5 V to 3.60 V
PLL Supply Voltage V_{CCPLL}	-0.5 V to 1.42 V
I/O Tri-state Voltage Applied	-0.5 V to 3.60 V
Dedicated Input Voltage Applied	-0.5 V to 3.60 V
Storage Temperature (Ambient)	-65 °C to 150 °C
Junction Temperature (T_J)	-65 °C to 125 °C

1. Stress above those listed under the “Absolute Maximum Ratings” may cause permanent damage to the device. Functional operation of the device at these or any other conditions above those indicated in the operational sections of this specification is not implied.
2. Compliance with the Lattice [Thermal Management](#) document is required.
3. All voltages referenced to GND.

Recommended Operating Conditions¹

Symbol	Parameter	Min.	Max.	Units		
V_{CC} ¹	Core Supply Voltage	1.14	1.26	V		
V_{PP_2V5}	VPP_2V5 NVCM Programming and Operating Supply Voltage	Slave SPI Configuration	1.71 ⁴	3.46	V	
		Master SPI Configuration	2.30	3.46	V	
		Configuration from NVCM	2.30	3.46	V	
		NVCM Programming	2.30	3.00	V	
V_{CCIO} ^{1, 2, 3}	I/O Driver Supply Voltage	V_{CCIO_0} , SPI_V_{CCIO1} , V_{CCIO_2}		1.71	3.46	V
V_{CCPLL}	PLL Supply Voltage	1.14	1.26	V		
t_{JCOM}	Junction Temperature Commercial Operation	0	85	°C		
t_{JIND}	Junction Temperature Industrial Operation	-40	100	°C		
t_{PROG}	Junction Temperature NVCM Programming	10.00	30.00	°C		

1. Like power supplies must be tied together if they are at the same supply voltage and they meet the power up sequence requirement. Please refer to [Power-Up Supply Sequencing](#) section. V_{CC} and V_{CCPLL} are recommended to tie to same supply with an RC-based noise filter between them. Please refer to TN1252, [iCE40 Hardware Checklist](#).
2. See recommended voltages by I/O standard in subsequent table.
3. V_{CCIO} pins of unused I/O banks should be connected to the V_{CC} power supply on boards.
4. V_{PP_2V5} can, optionally, be connected to a 1.8 V (+/-5%) power supply in Slave SPI Configuration mode subject to the condition that none of the HFOSC/LFOSC and RGB LED / IR LED driver features are used. Otherwise, V_{PP_2V5} must be connected to a power supply with a minimum 2.30 V level.

Power Supply Ramp Rates^{1, 2}

Symbol	Parameter	Min.	Max.	Units
t_{RAMP}	Power supply ramp rates for all power supplies.	0.6	10	V/ms

1. Assumes monotonic ramp rates.
2. Power up sequence must be followed. Please refer to [Power-Up Supply Sequencing](#) section.

Power-On Reset

All iCE40 Ultra devices have on-chip Power-On-Reset (POR) circuitry to ensure proper initialization of the device. Only three supply rails are monitored by the POR circuitry as follows: (1) V_{CC} , (2) SPI_V_{CCIO1} and (3) V_{PP_2V5} . All other supply pins have no effect on the power-on reset feature of the device. Note that all supply voltage pins must be connected to power supplies for normal operation (including device configuration).

Power-Up Supply Sequencing

It is recommended to bring up the power supplies in the following order. Note that there is no specified timing delay between the power supplies, however, there is a requirement for each supply to reach a level of 0.5V, or higher, before any subsequent power supplies in the sequence are applied.

1. V_{CC} and V_{CCPLL} should be the first two supplies to be applied. Note that these two supplies can be tied together subject to the recommendation to include a RC-based noise filter on the V_{CCPLL} (Please refer to TN1252, [iCE40 Hardware Checklist](#).)
2. SPI_V_{CCIO1} should be the next supply, and can be applied any time after the previous supplies (V_{CC} and V_{CCPLL}) have reached as level of 0.5 V or higher.
3. V_{PP_2V5} should be the next supply, and can be applied any time after previous supplies (V_{CC} , V_{CCPLL} and SPI_V_{CCIO1}) have reached a level of 0.5 V or higher.
4. **Other Supplies** (V_{CCIO0} and V_{CCIO2}) do not affect device power-up functionality, and they can be applied any time after the initial power supplies (V_{CC} and V_{CCPLL}) have reached a level of 0.5 V or greater.

There is no power down sequence required. However, when partial power supplies are powered down, it is required the above sequence to be followed when these supplies are repowered up again.

External Reset

When all power supplies have reached to their minimum operating voltage defined in Minimum Operation Condition Table, it is required to either keep $CRESET_B$ LOW, or toggle $CRESET_B$ from HIGH to LOW, for a duration of t_{CRESET_B} , and release it to go HIGH, to start configuration download from either the internal NVCM or the external Flash memory.

Figure 3-1 shows Power-Up sequence when SPI_V_{CCIO1} and V_{PP_2V5} are connected separately, and the $CRESET_B$ signal triggers configuration download. Figure 3-2 shows when SPI_V_{CCIO1} and V_{PP_2V5} connected together.

All power supplies should be powered up during configuration. Before and during configuration, the I/Os are held in tri-state. I/Os are released to user functionality once the device has finished configuration.

Figure 3-1. Power Up Sequence with SPI_V_{CCIO1} and V_{PP_2V5} Not Connected Together

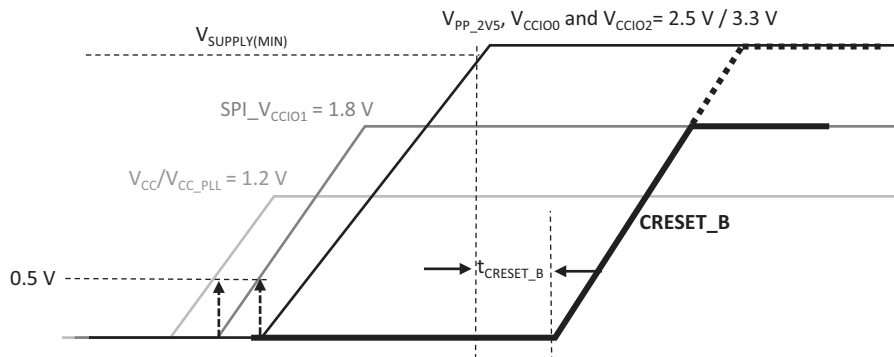
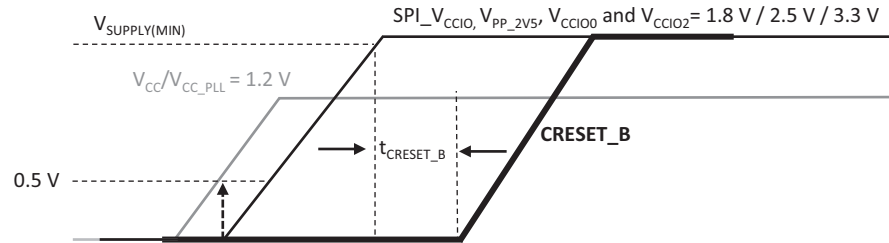

Figure 3-2. Power Up Sequence with All Supplies Connected Together



Power-On-Reset Voltage Levels¹

Symbol	Parameter	Min.	Max.	Units	
V_{PORUP}	Power-On-Reset ramp-up trip point (circuit monitoring V_{CC} , SPI_V_{CCIO1} , V_{PP_2V5})	V_{CC}	0.62	0.92	V
		SPI_V_{CCIO1}	0.87	1.50	V
		V_{PP_2V5}	0.90	1.53	V
V_{PORDN}	Power-On-Reset ramp-down trip point (circuit monitoring V_{CC} , SPI_V_{CCIO1} , V_{PP_2V5})	V_{CC}	—	0.79	V
		SPI_V_{CCIO1}	—	1.50	V
		V_{PP_2V5}	—	1.53	V

1. These POR trip points are only provided for guidance. Device operation is only characterized for power supply voltages specified under recommended operating conditions.

ESD Performance

Please contact Lattice Semiconductor for additional information.

DC Electrical Characteristics

Over Recommended Operating Conditions

Symbol	Parameter	Condition	Min.	Typ.	Max.	Units
I_{IL} , I_{IH} ^{1,3,4}	Input or I/O Leakage	$0V < V_{IN} < V_{CCIO} + 0.2V$	—	—	+/-10	μA
C_1	I/O Capacitance, excluding LED Drivers ²	$V_{CCIO} = 3.3V, 2.5V, 1.8V$ $V_{CC} = Typ., V_{IO} = 0 \text{ to } V_{CCIO} + 0.2V$	—	6	—	pF
C_2	Global Input Buffer Capacitance ²	$V_{CCIO} = 3.3V, 2.5V, 1.8V$ $V_{CC} = Typ., V_{IO} = 0 \text{ to } V_{CCIO} + 0.2V$	—	6	—	pF
C_3	RGB Pin Capacitance ²	$V_{CC} = Typ., V_{IO} = 0 \text{ to } 3.5V$	—	15	—	pF
C_4	IRLED Pin Capacitance ²	$V_{CC} = Typ., V_{IO} = 0 \text{ to } 3.5V$	—	53	—	pF
V_{HYST}	Input Hysteresis	$V_{CCIO} = 1.8V, 2.5V, 3.3V$	—	200	—	mV
I_{PU}	Internal PIO Pull-up Current	$V_{CCIO} = 1.8V, 0 \leq V_{IN} \leq 0.65 V_{CCIO}$	-3	—	-31	μA
		$V_{CCIO} = 2.5V, 0 \leq V_{IN} \leq 0.65 V_{CCIO}$	-8	—	-72	μA
		$V_{CCIO} = 3.3V, 0 \leq V_{IN} \leq 0.65 V_{CCIO}$	-11	—	-128	μA

1. Input or I/O leakage current is measured with the pin configured as an input or as an I/O with the output driver tri-stated. It is not measured with the output driver active. Internal pull-up resistors are disabled.

2. T_J 25 °C, $f = 1.0$ MHz.

3. Please refer to V_{IL} and V_{IH} in the sysIO Single-Ended DC Electrical Characteristics table of this document.

4. Input pins are clamped to V_{CCIO} and GND by a diode. When input is higher than V_{CCIO} or lower than GND, the Input Leakage current will be higher than the I_{IL} and I_{IH} .

Supply Current ^{1, 2, 3, 4, 5}

Symbol	Parameter	Typ. $V_{CC} = 1.2 V^4$	Units
$I_{CCSTDBY}$	Core Power Supply Static Current	71	μA
$I_{PP2V5STDBY}$	V_{PP_2V5} Power Supply Static Current	0.55	μA
$I_{SPI_VCCIO1STDBY}$	SPI_V_{CCIO1} Power Supply Static Current	0.5	μA
$I_{CCIOSTDBY}$	V_{CCIO} Power Supply Static Current	0.5	μA
I_{CCPEAK}	Core Power Supply Startup Peak Current	8.0	mA
$I_{PP_2V5PEAK}$	V_{PP_2V5} Power Supply Startup Peak Current	7.0	mA
$I_{SPI_VCCIO1PEAK}$	SPI_V_{CCIO1} Power Supply Startup Peak Current	9.0	mA
$I_{CCIOPEAK}$	V_{CCIO} Power Supply Startup Peak Current	7.5	mA

- Assumes blank pattern with the following characteristics: all outputs are tri-stated, all inputs are configured as LVCMOS and held at V_{CCIO} or GND, on-chip PLL is off. For more detail with your specific design, use the Power Calculator tool. Power specified with master SPI configuration mode. Other modes may be up to 25% higher.
- Frequency = 0 MHz.
- $T_J = 25^\circ C$, power supplies at nominal voltage, on devices processed in nominal process conditions.
- Does not include pull-up.
- Startup Peak Currents are measured with decoupling capacitance of 0.1 μF , 10 nF, and 1 nF to the power supply. Higher decoupling capacitance causes higher current.

User I²C Specifications

Parameter Symbol	Parameter Description	spec (STD Mode)			spec (FAST Mode)			Units
		Min	Typ	Max	Min	Typ	Max	
f_{SCL}	Maximum SCL clock frequency	—	—	100	—	—	400	kHz
t_{HI}	SCL clock HIGH Time	4	—	—	0.6	—	—	μs
t_{LO}	SCL clock LOW Time	4.7	—	—	1.3	—	—	μs
$t_{SU,DAT}$	Setup time (DATA)	250	—	—	100	—	—	ns
$t_{HD,DAT}$	Hold time (DATA)	0	—	—	0	—	—	ns
$t_{SU,STA}$	Setup time (START condition)	4.7	—	—	0.6	—	—	μs
$t_{HD,STA}$	Hold time (START condition)	4	—	—	0.6	—	—	μs
$t_{SU,STO}$	Setup time (STOP condition)	4	—	—	0.6	—	—	μs
t_{BUF}	Bus free time between STOP and START	4.7	—	—	1.3	—	—	μs
$t_{CO,DAT}$	SCL LOW to DATAOUT valid	—	—	3.4	—	—	0.9	μs

User SPI Specifications ^{1, 2}

Parameter Symbol	Parameter Description	Min	Typ	Max	Units
f_{MAX}	Maximum SCK clock frequency	—	—	45	MHz

- All setup and hold time parameters on external SPI interface are design-specific and, therefore, generated by the Lattice Design Software tools. These parameters include the following:
 - $t_{SUmaster}$ master Setup time (master mode)
 - $t_{HOLDmaster}$ master Hold time (master mode)
 - $t_{SUslave}$ slave Setup time (slave mode)
 - $t_{HOLDslave}$ slave Hold time (slave mode)
 - $t_{SCK2OUT}$ SCK to out (slave mode)
- The SCLK duty cycle needs to be specified in the Lattice Design Software as a timing constraint in order to ensure proper timing check on SCLK HIGH and LOW (t_{HI} , t_{LO}) time.

Internal Oscillators (HFOSC, LFOSC)¹

Parameter		Parameter Description	Spec/Recommended			Units
Symbol	Conditions		Min	Typ	Max	
f _{CLKHF}	Commercial Temp	HFOSC clock frequency (t _J = 0 °C–85 °C)	–10%	48	10%	MHz
	Industrial Temp	HFOSC clock frequency (t _J = –40 °C–100 °C)	–20%	48	20%	MHz
f _{CLKLF}		LFOSC CLKK clock frequency	–10%	10	10%	kHz
DCH _{CLKHF}	Commercial Temp	HFOSC clock frequency (t _J = 0 °C–85 °C)	45	50	55	%
	Industrial Temp	HFOSC clock frequency (t _J = –45 °C–100 °C)	40	50	60	%
DCH _{CLKLF}		LFOSC Duty Cycle (Clock High Period)	45	50	55	%
Tsync_on		Oscillator output synchronizer delay	—	—	5	Cycles
Tsync_off		Oscillator output disable delay	—	—	5	Cycles

1. Glitchless enabling and disabling OSC clock outputs.

sysIO Recommended Operating Conditions

Standard	V _{CCIO} (V)		
	Min.	Typ.	Max.
LVC MOS 3.3	3.14	3.3	3.46
LVC MOS 2.5	2.37	2.5	2.62
LVC MOS 1.8	1.71	1.8	1.89

sysIO Single-Ended DC Electrical Characteristics

Input/ Output Standard	V _{IL}		V _{IH}		V _{OL} Max. (V)	V _{OH} Min. (V)	I _{OL} Max. (mA)	I _{OH} Max. (mA)
	Min. (V)	Max. (V)	Min. (V)	Max. (V)				
LVC MOS 3.3	–0.3	0.8	2.0	V _{CCIO} + 0.2V	0.4	V _{CCIO} – 0.4	8	–8
					0.2	V _{CCIO} – 0.2	0.1	–0.1
LVC MOS 2.5	–0.3	0.7	1.7	V _{CCIO} + 0.2V	0.4	V _{CCIO} – 0.4	6	–6
					0.2	V _{CCIO} – 0.2	0.1	–0.1
LVC MOS 1.8	–0.3	0.35V _{CCIO}	0.65V _{CCIO}	V _{CCIO} + 0.2V	0.4	V _{CCIO} – 0.4	4	–4
					0.2	V _{CCIO} – 0.2	0.1	–0.1

Differential Comparator Electrical Characteristics

Parameter Symbol	Parameter Description	Test Conditions	Min.	Max.	Units
V _{REF}	Reference Voltage to compare, on V _{INM}	V _{CCIO} = 2.5 V	0.25	V _{CCIO} – 0.25 V	V
V _{DIFFIN_H}	Differential input HIGH (V _{INP} – V _{INM})	V _{CCIO} = 2.5 V	250	—	mV
V _{DIFFIN_L}	Differential input LOW (V _{INP} – V _{INM})	V _{CCIO} = 2.5 V	—	–250	mV
I _{IN}	Input Current, V _{INP} and V _{INM}	V _{CCIO} = 2.5 V	–10	10	μA

Signal Descriptions

Signal Name	Function	I/O	Description
Power Supplies			
V _{CC}	Power	—	Core Power Supply
V _{CCIO_0} , SPI_V _{CCIO1} , V _{CCIO_2}	Power	—	Power for I/Os in Bank 0, 1, and 2.
V _{PP_2V5}	Power	—	Power for NVCM programming and operations
V _{CCPLL}	Power	—	Power for PLL.
GND	GROUND	—	Ground
Configuration			
CRESETB	Configuration	I	Configuration Reset, active LOW. No internal pull-up resistor. Either actively driven externally or connect an 10 k-Ohm pull-up to V _{CCIO_1}
CDONE	Configuration	I/O	Configuration Done. Includes a weak pull-up resistor to V _{CCIO_1}
	General I/O	I/O	In user mode, after configuration, this pin can be programmed as general I/O in user function
Config SPI			
SPI_SCK	Configuration	I/O	This pin is shared with device configuration. During configuration: In Master SPI mode, this pin outputs the clock to external SPI memory. In Slave SPI mode, this pin inputs the clock from external processor.
	General I/O	I/O	In user mode, after configuration, this pin can be programmed as general I/O in user function
SPI_SDO	Configuration	Output	This pin is shared with device configuration. During configuration: In Master SPI mode, this pin outputs the command data to external SPI memory. In Slave SPI mode, this pin connects to the MISO pin of the external processor.
	General I/O	I/O	In user mode, after configuration, this pin can be programmed as general I/O in user function
SPI_SI	Configuration	Input	This pin is shared with device configuration. During configuration: In Master SPI mode, this pin receives data from external SPI memory. In Slave SPI mode, this pin connects to the MOSI pin of the external processor.
	General I/O	I/O	In user mode, after configuration, this pin can be programmed as general I/O in user function

SPI_CSN	Configuration	I/O	This pin is shared with device configuration. During configuration: In Master SPI mode, this pin outputs to the external SPI memory. In Slave SPI mode, this pin inputs CSN from the external processor.
	General I/O	I/O	In user mode, after configuration, this pin can be programmed as general I/O in user function
CC1_RP		O	Enable signal to Connect RP to CC1 line 1:RP connected to CC1 line Z:RP not connected to CC1 line
CC1_TX		O	Configuration channel TX for CC1 line
CC1_TX_EN		O	Enable signal for CC1_TX 0:CC1_TX connected to CC1 line Z:CC1_TX not connected to CC1 line
CC1_DET		I	Cable detection on CC1 line
CC1_RX		I	Configuration channel RX for CC1 line
CC1_RD		O	Enable signal to Connect RD to CC1 line 0:RD connected to CC1 line Z:RD not connected to CC1 line
CC1_VCONN_EN		O	VCONN Enable 1:VCONN enabled on CC1 line 0:VCONN disabled on CC1 line
CC1_VCONN_EN_n		O	VCONN Enable 1:VCONN disabled on CC1 line 0:VCONN enabled on CC1 line
CC2_RP		O	Enable signal to Connect RP to CC2 line 1:RP connected to CC2 line Z:RP not connected to CC2 line
CC2_TX		O	Configuration channel TX for CC2 line
CC2_TX_EN		O	Enable signal for CC2_TX 0:CC2_TX connected to CC2 line Z:CC2_TX not connected to CC2 line
CC2_DET		I	Cable detection on CC2 line
CC2_RX		I	Configuration channel RX for CC2 line
CC2_RD		O	Enable signal to Connect RD to CC2 line 0:RD connected to CC2 line Z:RD not connected to CC2 line
CC2_VCONN_EN		O	VCONN Enable 1:VCONN enabled on CC2 line 0:VCONN disabled on CC2 line
CC2_VCONN_EN_n		O	VCONN Enable 1:VCONN disabled on CC2 line 0:VCONN enabled on CC2 line
CC_RX_REF		I	Reference Signal for CC1_RX and CC2_RX
CC1_DET_REF		I	Reference Signal for CC1_DET
CC1_DET_PWM		O	PWM signal to generate CC1_DET_REF
CC2_DET_REF		I	Reference Signal for CC2_DET

CC2_DET_PWM	O	PWM signal to generate CC2_DET_REF
DB_DISABLE	O	Disable signal to disable Dead battery MOSFET's
		1:Dead Battery MOSFE's disabled
		0:Dead Battery MOSFE's enabled
VBUS_SOURCE_EN	O	Enable Signal for VBUS Source
VBUS_SINK_EN	O	Enable Signal for VBUS Sink
VBUS_DSICHARGE_EN	O	Enable Signal for VBUS Discharge
		1:VBUS Discharge enabled
		0:VBUS Discharge disabled
VBUS_DET	I	VBUS detect and monitor signal
VBUS_REF	I	Reference signal for VBUS_DET
VBUS_DET_PWM		PWM signal to generate VBUS_REF
SS_SEL1, SS_SEL2, SS_SEL3	O	SS/HS Switch Control Signal
CLK_IN	I	4.8 MHz Clock or Even Multiples of 4.8 MHz such as 9.6 MHz or 19.2 MHz etc. LIF-UC110 and LIF-UC120 devices have an internal oscillator. It can also be used if the customer prefers not to use external clock source.
SPI_MISO	I/O	This pin is shared with device configuration and EC.After configuration. This pin is used SPI_MISO for EC.
SPI_MOSI	I/O	This pin is shared with device configuration and EC.After configuration. This pin is used SPI_MOSI for EC.
SPI_SCK	I/O	This pin is shared with device configuration and EC.After configuration. This pin is used SPI_SCK for EC.
SPI_SS_B	I	Chip select signal for Device configuration
EC_INT	O	Interrupt signal from FPGA to EC
EC_CS	I	Chip select signal from EC to FPGA
CDONE	I/O	Configuration Done. Includes a weak pull-up resistor to VCCIO_1
CRESETB	I	Configuration Reset, active LOW. No internal pull-up resistor. Either actively driven externally or connect an 10K-ohm pull-up to VCCIO_1
VSEL1,VSEL2,VSEL3,VSEL4	I/O	Voltage selection line 1 for selecting output voltage
VBUS_PG	O	VBUS power good signal
HPD	I/O	Hot Plug detect.
CC1_RX_REF	I	CC1 RX From external comparator
CC2_RX_REF	I	CC2 RX From external comparator
VBUS_IN	I	VBUS sense Input from the Connector
CC1_DET	I	CC1 input from the for cable detection
CC2_DET	I	CC2 input from the for cable detection



Lattice USB Type-C Solution Data Sheet Ordering Information

August 2016

Data Sheet DS1052

Ordering Part Numbers

Part Number	Functional Description	Supply Voltage	Package	Pins	Temp.
LIF-UC110-SG48I	CD/PD for Charger	1.2 V	QFN	48	IND
LIF-UC140-CM81I	CD/PD for Hosts/Devices	1.2 V	CBGA	81	IND

Date	Version	Section	Change Summary
August 2016	1.4	All	Changed document status from Preliminary to final.
		Introduction	Updated the Features section. — Removed CD/PD-Phy for hosts/devices; CD/PD for Docks/Dockable Devices; 36 WLCSP; and 36 ucBGA. — Updated Table 1-1, USB Type-C Device Table.
		Architecture	Updated the USB CD/PD Charger Solution (Captive Cable) section. — Revised Figure 2-2, USB CD/PD Charger Solution (Captive Cable) Schematic Diagram. — Updated Table 2-1, USB CD/PD Charger Solution (Captive Cable) BOM. Revised Items 1, 2, 10 and 11. — Updated Table 2-3, USB CD/PD Charger Solution (Captive Cable) BOM Count. Revised Items 1 and 3.
			Updated the USB CD/PD Charger Solution (Non-Captive Cable) section. — Revised Figure 2-5, USB CD/PD Charger Solution (Non-Captive Cable) Schematic Diagram. — Updated Table 2-3, USB CD/PD Charger Solution (Non-Captive Cable) BOM. Revised Items 1, 4, 10 and 11. — Updated Table 2-4, USB CD/PD Charger Solution (Non-Captive Cable) BOM Count. Revised Items 2 and 3.
			Removed the CD/PD PHY for Host/Devices section.
			Updated the CD/PD for Hosts/Devices section. — Removed note in features. — Revised Figure 2-7, CD/PD for Host/Devices Schematic Diagram. — Updated Table 2-5, CD/PD for Hosts/Devices BOM. Revised Item 3. — Updated Table 2-6, CD/PD for Hosts/Devices BOM Count. Revised Items 1, 2, 3 and 4. Corrected item 7.
			Updated Absolute Maximum Ratings section. — Corrected symbol character format.
		DC and Switching Characteristics	Updated Recommended Operating Conditions section. — Corrected symbol character format. — Revised footnote 1. — Added footnote 4.
			Added Power-On Reset section.
			Updated section heading to Power-Up Supply Sequencing . Revised text content.
			Added External Reset section.
			Updated DC Electrical Characteristics section. Revised footnote 4.
			Updated Supply Current section. — Corrected $I_{PP2V5STDBY}$ parameter. — Added Typ. VCC = 1.2 V values for I_{CCPEAK} , $I_{PP_2V5PEAK}$, $I_{SPI_VCCIO1PEAK}$, and $I_{CCIOPEAK}$. — Added footnote 5. — Corrected S_{PI_VCCIO1} character format.
Updated User SPI Specifications section. Removed parameters and added footnotes.			
Updated Internal Oscillators (HFOSC, LFOSC) section. Added Commercial and Industrial Temp values for DCH_{CLKHF}			

Date	Version	Section	Change Summary
			Updated sysIO Single-Ended DC Electrical Characteristics section. Removed footnote.
		Ordering Information	Updated the Ordering Part Numbers section.
August 2015	1.3	Introduction	Updated the Features section. — Removed 81 caBGA under Wide Range of Packages to Match PCB Technology feature. — Updated Table 1-1, USB Type-C Device Table. Revised heading to Package, Ball Pitch, Dimension and updated data. Removed the 81 BGA, 0.8 mm, 8 mm x 8 mm package.
		Architecture	Updated the Architecture Overview section. Revised Figure 2-1, High-level Functional Block for USB Type-C Physical Layer and Power Detect Protocol.
			Updated the USB CD/PD Charger Solution (Captive Cable) section. Revised Figure 2-2, USB CD/PD Charger Solution (Captive Cable) Block Diagram.
			Updated the USB CD/PD Charger Solution (Non-Captive Cable). Revised Figure 2-4, USB CD/PD Charger Solution (Non-Captive Cable) Block Diagram
			Updated the CD/PD PHY for Host/Devices. Revised Figure 2-6, CD/PD PHY for Host/Devices Block Diagram.
			Updated the CD/PD for Hosts/Devices. Revised Figure 2-6, CD/PD for Host/Devices Block Diagram.
Ordering Information	Updated Ordering Part Numbers section. Removed LIF-UC140-BG811 part number.		
June 2015	1.2	Architecture	Updated the USB CD/PD Charger Solution (Non-Captive Cable) section. — Modified Figure 2-5, USB CD/PD Charger Solution (Non-Captive Cable) Schematic Diagram. Added VCONN switch for SOP support. — Updated Table 2-3, CD/PD for Hosts/Devices BOM. USB CD/PD Charger Solution (Non-Captive Cable) BOM. Revised Item 12. Added Item 20. — Updated Table 2-4, USB CD/PD Charger Solution (Non-Captive Cable) BOM Count. Revised Item 3. Added Item 5.
			Updated the CD/PD PHY for Host/Devices section. Added note in supported features in schematics.
			Updated the CD/PD for Hosts/Devices section. — Added note in supported features in schematics. — Modified Figure 2-7, CD/PD for Hosts/Devices Schematic Diagram. Changed R38 and R39 resistor values to 5.1 kOhm. — Updated Table 2-5, CD/PD for Hosts/Devices BOM. Revised Items 15 and 18.
March 2015	1.1	Architecture	Updated the USB CD/PD Charger Solution (Captive Cable) section. Modified Figure 2-3, USB CD/PD Charger Solution (Captive Cable) Schematic Diagram. — Updated BMX TX resistor values. — Added RC Circuit provision for BMC reference voltage. — Added pull-up resistors for CDONE. Updated Table 2-1, USB CD/PD Mobile System Solution (Captive Cable) BOM and Table 2-2, USB CD/PD Mobile System Solution (Captive Cable) BOM Count.

Date	Version	Section	Change Summary
			<p>Updated the USB CD/PD Charger Solution (Non-Captive Cable) section.</p> <p>Modified Figure 2-5, USB CD/PD Charger Solution (Non-Captive Cable) Schematic Diagram.</p> <ul style="list-style-type: none"> — Updated BMX TX resistor values. — Added RC Circuit provision for BMC reference voltage. — Added pull-up resistors for CDONE. <p>Updated Table 2-3, USB CD/PD Charger Solution (Non-Captive Cable) BOM and Table 2-4, USB CD/PD Charger Solution (Non-Captive Cable) BOM Count.</p> <hr/> <p>Updated the CD/PD PHY for Host/Devices section.</p> <p>Modified Figure 2-6, CD/PD Phy for Host/Devices Block Diagram.</p> <p>Removed items in Features Supported in Schematics.</p> <p>Modified Figure 2-7, CD/PD Phy for Hosts/Devices Schematic Diagram.</p> <ul style="list-style-type: none"> — Updated BMX TX resistor values. <p>Updated Table 2-5, CD/PD Phy for Hosts/Devices BOM and Table 2-6, CD/PD Phy for Hosts/Devices BOM Count.</p> <hr/> <p>Updated the CD/PD for Hosts/Devices section.</p> <p>Modified Figure 2-9, CD/PD for Hosts/Devices Schematic Diagram.</p> <ul style="list-style-type: none"> — Updated BMX TX resistor values. — Added dead battery circuit. — Moved DB-Disable signal to CDONE pin. — Changed Rx Comparator Power supply voltage to 3.3 V. <p>Added Table 2-7, CD/PD for Hosts/Devices BOM and Table 2-6, CD/PD for Hosts/Devices BOM Count.</p> <hr/> <p>Pinout Information</p> <p>Updated Signal Descriptions section.</p>
February 2015	1.0	All	Initial release.

Looking for pricing, stock, or lifecycle information?

Click below to explore more details on WIN SOURCE:

- ⊖ [View LIF-UC120-SWG36ITR50 on WIN SOURCE](#)
- ⊖ [Lattice Semiconductor Corporation Information](#)

Optimize Your Supply Chain with WIN SOURCE Solutions

- ✓ Global Sourcing Solution
- ✓ Obsolete Management
- ✓ Cost Control Management
- ✓ Shortage Management
- ✓ Alternative Solution
- ✓ Excess Inventory Management