



**THE DATASHEET OF
DF38A-30S-0.3V(51)**



0.3 mm Pitch, 1.5 mm Mated Height, Board- to-Fine Coaxial Cable Connectors

DF38 Series

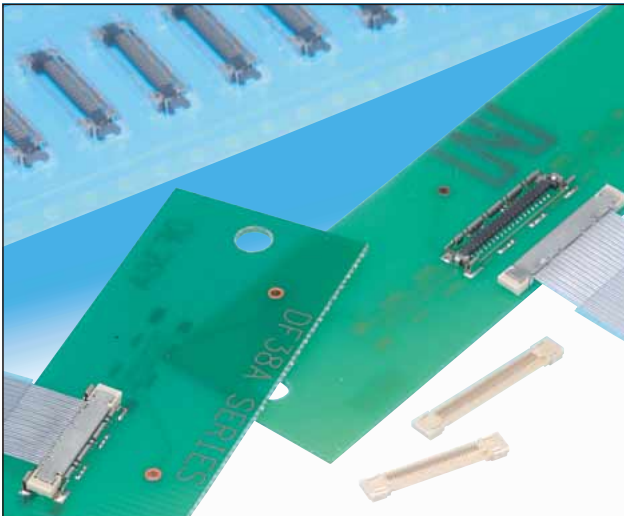

**High contact reliability –
Effective mating length of 0.4 mm**

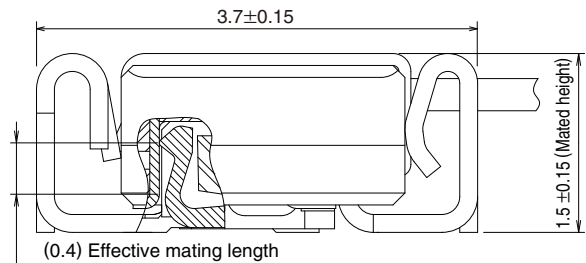

■ Features

1. Small mated height and board occupied space

Small pitch (0.3mm) and mated height (1.5mm) allows use in space-restricted areas.

Plug's height of 1.3mm and width of 2.38mm allow its passage through narrow openings in small-diameter hinge applications.

2. Enhanced shielding and ground connections

Metal shells on the plug and receptacle connect to each other with a reliable multi-point ground contacts, assuring reliable ground connection and EMC protection.

3. Reliable lock

Fully mated condition is assured with reliable locks at 4 locations, confirming it with a distinct tactile click.

4. Reliable electrical and mechanical connection

Despite its small mated height, unique contact configuration assures highly reliable connection, with effective mating length of 0.4mm.

5. Solder wicking prevention

Nickel barriers prevent solder wicking in the critical contact areas.

6. Durable plug construction

Formed metal shells on the top and side surfaces form a strong and rigid assembly.

7. RoHS, Halogen-free*

*As defined by IEC61249-2-21

Br-900 ppm maximum, Cl-900 ppm maximum, Cl+Br combined-1,500 ppm maximum

Enhanced shielding

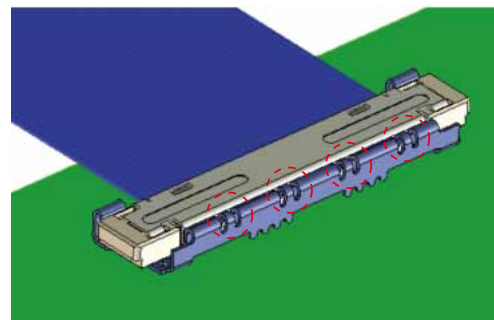

Multi-point ground contacts

4-point lock: 2 points at each end

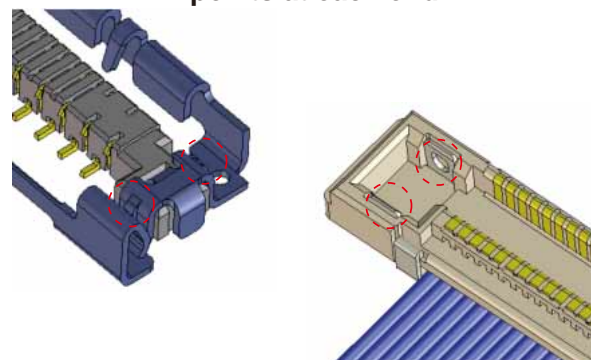

Distinct tactile click

■ Connector for conductivity tests

We have a line-up of connectors for inspection, usable for electrical testing of both plug and receptacle connectors.

Specifications

Ratings	Current rating	Wire size AWG #42: 0.15 A AWG #44: 0.1 A (Note.3) AWG #46: 0.1 A	Operating temperature range Operating humidity range	-35 to +85°C (Note 1) RH 20% to 80%
	Voltage rating	30 V AC	Storage temperature range Storage humidity range	-10 to +60°C (Note 2) RH 40% to 70% (Note 2)

Item	Specification	Conditions
1. Insulation resistance	50MΩ min	100V DC
2. Withstanding voltage	No flashover or insulation breakdown	100 V AC / 1 minute
3. Contact resistance	Signal: 80mΩ max., Ground: 80mΩ max.	100mA (DC or 1,000Hz)
4. Vibration	No electrical discontinuity of 1 μs or longer	Frequency: 10 to 55 Hz, single amplitude of 0.75 mm, 3 directions, 2 hours
5. Humidity	Contact resistance (change from initial value) 50 mΩ max. Insulation resistance: 25 MΩ min.	96 hours at of 40 ±2°C, and humidity of 90 to 95%
6. Temperature cycle	Contact resistance (change from initial value) 50 mΩ max. Insulation resistance: 50 MΩ min.	-55°C → 5 to 35°C → 85°C → 5 to 35°C Time: 30 min. → 2 to 3 min. → 30 min. → 2 to 3 min. 5 cycles
7. Durability	Contact resistance (change from initial value) 50 mΩ max.	30 cycles
8. Resistance to soldering heat	No deformation of affecting performance	Reflow: At the recommended temperature profile Manual soldering: 350°C for 3 seconds

Note 1: Includes temperature rise caused by current flow.

Note 2: The term "storage" refers to products stored for a long period prior to mounting and use.

The operating temperature and humidity range covers the non-conducting condition of connectors after board mounting and the temporary storage conditions of transportation, etc.

Note 3: With only the connector portion at an elevated temperature level, the rated current value is set.

Material

Product	Part	Material	Finish	Remarks
Receptacle	Insulator	LCP	Color: Black	UL94-V0
	Contacts	Phosphor bronze	Gold plating	————
	Metal cover		Tin plating	————
	Vacuum cap	Polyamide	Color: Black	UL94-HB
Plug	Insulator	LCP	Color: Natural, Black	UL94-V0
	Contacts	Phosphor bronze	Gold plating	————
	Metal cover		Tin plating	————

Ordering information

Connector

DF 38 A J - * S - 0.3 V ()**
 ① ② ③ ④ ⑤ ⑥ ⑦ ⑧ ⑨

DF 38 J - * P - SHL
 ① ② ④ ⑤ ⑥ ⑩

① Series name : DF	⑥ Connector type S : Receptacle P : Plug
② Series No. : 38	⑦ Contact pitch : 0.3mm
③ Insulator typestyle Receptacle A : Standard Plug Blank : Standard	⑧ Termination type V : Straight SMT SD : Fine coaxial cable plug
④ Connector style Receptacle/Shell J : Receptacle for conductivity tests Blank : Standard	⑨ Packaging (51) : Embossed tape packaging
⑤ Number of positions : 30, 32, 40	⑩ Installation item (separate) SHL : Metal cover

Combinations

Standard use

DF38A-*S-0.3V(**) + DF38-*P-ASSY
 (DF38-*P-0.3SD(**)
 DF38-*P-SHL)

Note: The product specification of the above combination is shown on page 2.

Receptacle conductivity test

DF38A-*S-0.3V(**) + DF38J-*P-ASSY ... (Note)
 (DF38-*P-0.3SD(**)
 DF38J-*P-SHL)

Note: This harness item is only usable for the receptacle test.

For the product specification of the above combination, please contact our sales department.

Plug conductivity test

DF38AJ-*S-0.3V(**) ... (Note) + DF38-*P-ASSY
 (DF38-*P-0.3SD(**)
 DF38-*P-SHL)

Note: This harness item is only usable for the plug test.

For the product specification of the above combination, please contact our sales department.

* : ASSY means a harness item.

Receptacles

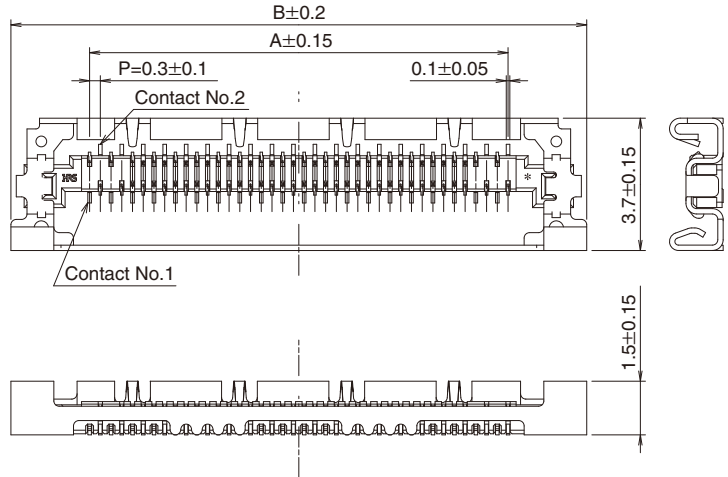
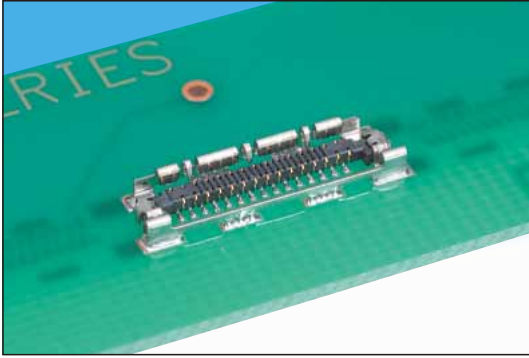

Recommended PCB mounting pattern

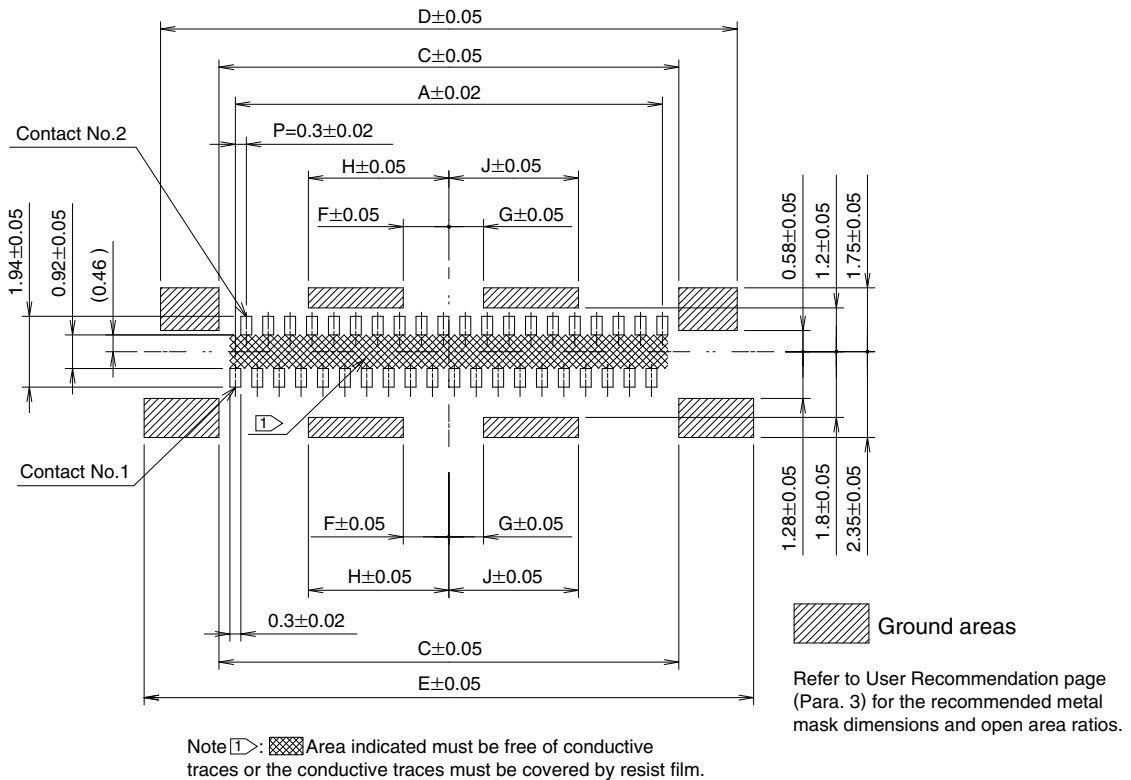

[Specifications number] - **, (**)
 (51) : Embossed tape packaging
 (5,000 pieces per reel)

All dimensions: mm

Part Number	CL No.	Number of Contacts	A	B	C	D	E	F	G	H	J
DF38A-30S-0.3V(**)	662-4505-4-***	30	8.7	13.1	9.6	12.8	13.7	0.95	1.25	2.95	3.25
DF38A-32S-0.3V(**)	662-4028-7-***	32	9.3	13.7	10.2	13.4	14.3	1.25	0.95	3.25	2.95
DF38A-40S-0.3V(**)	662-4501-3-***	40	11.7	16.1	12.6	15.8	16.7	1.25	0.95	3.85	3.55

Note 1: Tape and reel packaging (5,000 pieces/reel).
 Order by number of reels.

■ Plug - separate metal cover required

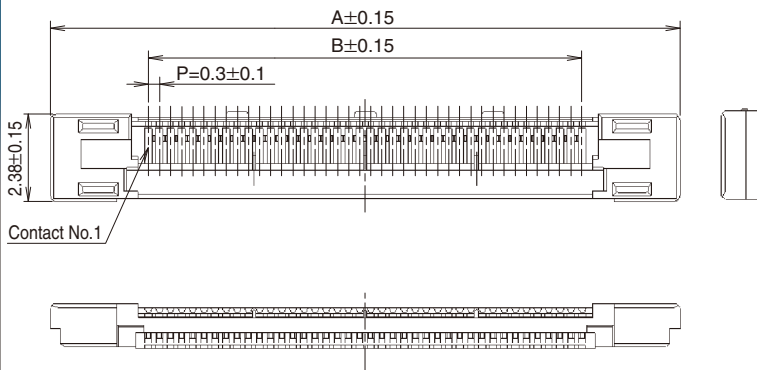
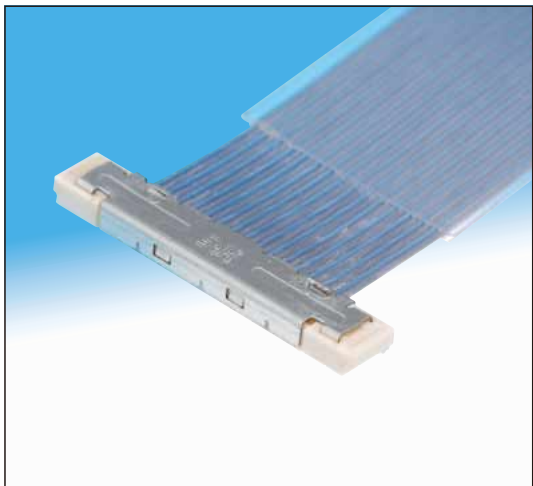

[Specifications number] - **, (**)
 (51) : Embossed tape packaging
 (5,000 pieces per reel)

All dimensions: mm

Part Number	CL No.	Number of Contacts	A	B	C
DF38B-30P-0.3SD(**)	662-4515-8-**-	30	14.0	8.7	9.55
DF38-32P-0.3SD(**)	662-4027-4-**-	32	14.6	9.3	10.15
DF38-40P-0.3SD(**)	662-4502-6-**-	40	17.0	11.7	12.55

Note 1: Tape and reel packaging (5,000 pieces/reel).
 Order by number of reels.
 Note 2: The metal cover is required for fine coaxial cable termination.

■ Recommended Fine Coaxial Cable Preparation

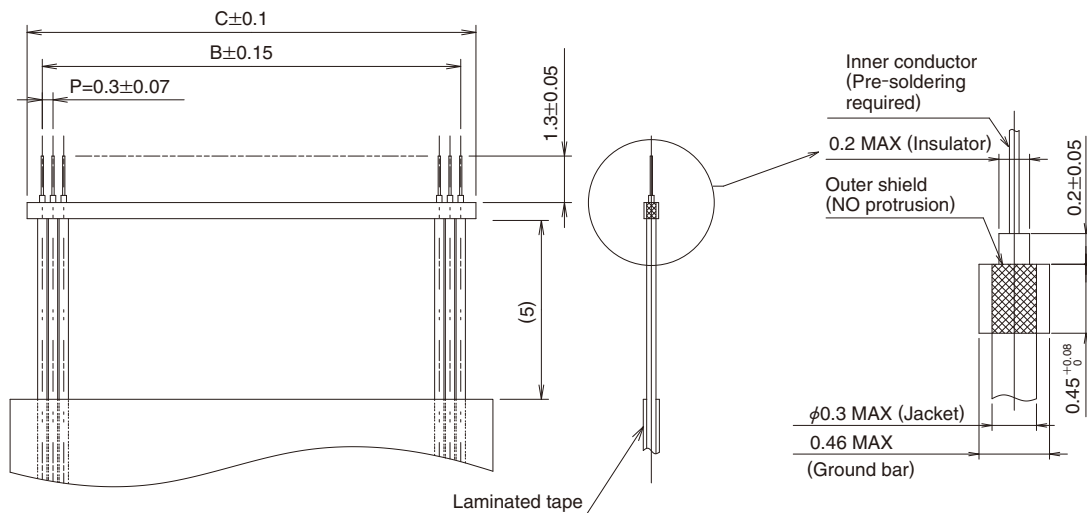

Note 1: Contact Hirose for Termination Procedures.

■ Metal cover - Required for assembly of the Plug

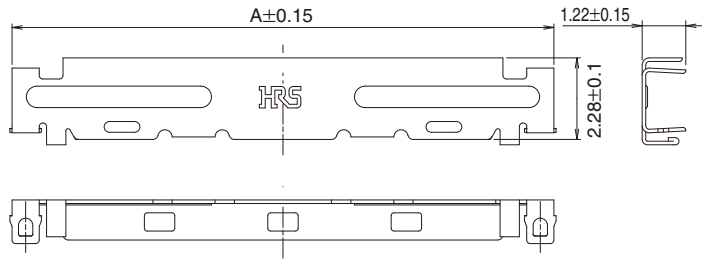
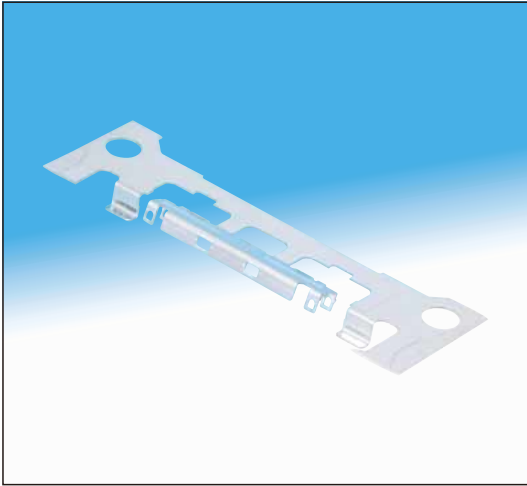

All dimensions: mm

Part Number	CL No.	Number of Contacts	A
DF38-30P-SHL	662-4507-0	30	12.15
DF38-32P-SHL	662-4029-0	32	12.75
DF38-40P-SHL	662-4503-9	40	15.15

Note 1: Reel packaging (10,000 pieces/reel).
Order by number of reels.

■ Embossed Carrier Tape Dimensions (JIS C 0806)

● Receptacle

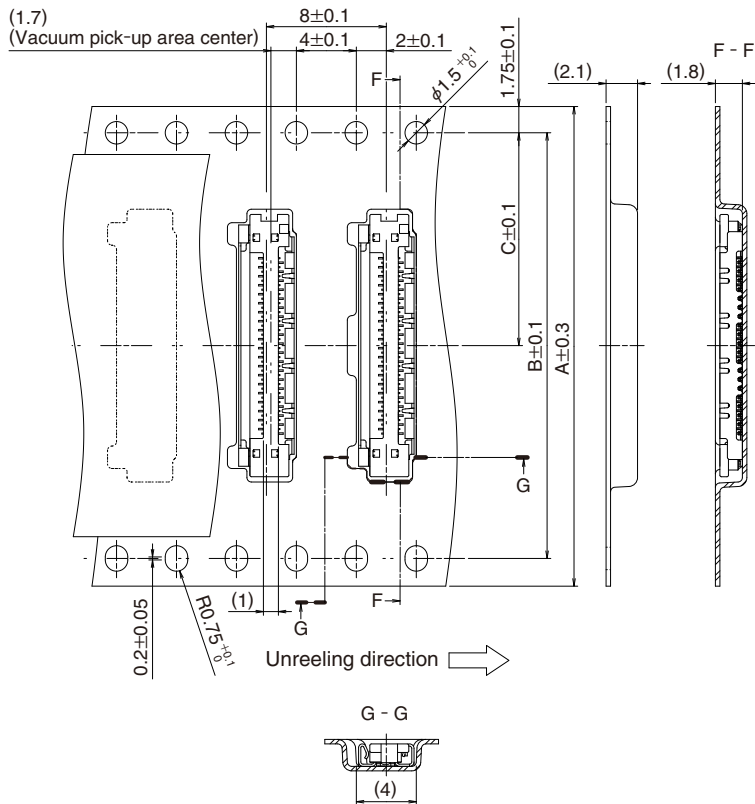

● Reel Dimensions

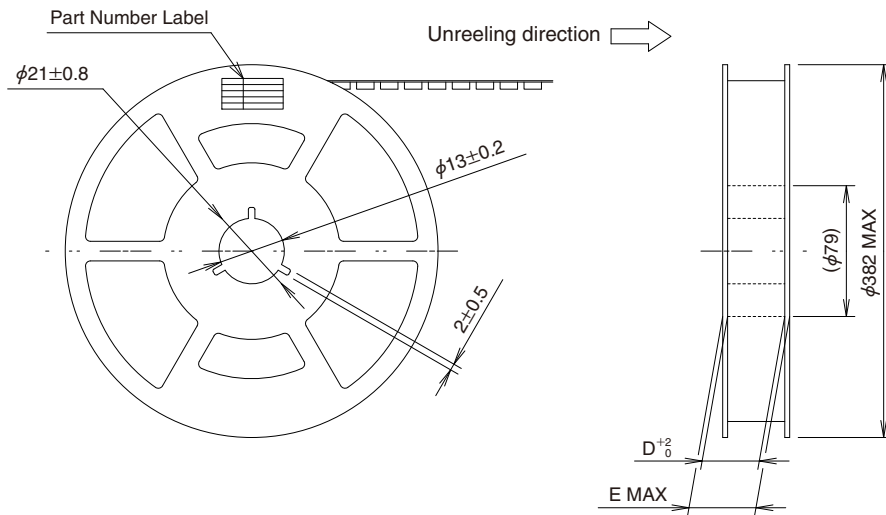

All dimensions: mm

Part Number	CL No.	Number of Contacts	A	B	C	D	E
DF38A-30S-0.3V(51)	662-4505-4-51	30	32	28.4	14.2	32.4	38.4
DF38A-32S-0.3V(51)	662-4028-7-51	32	32	28.4	14.2	32.4	38.4
DF38A-40S-0.3V(51)	662-4501-3-51	40	32	28.4	14.2	32.4	38.4

■ Embossed Carrier Tape Dimensions (JIS C 0806)

● Plug

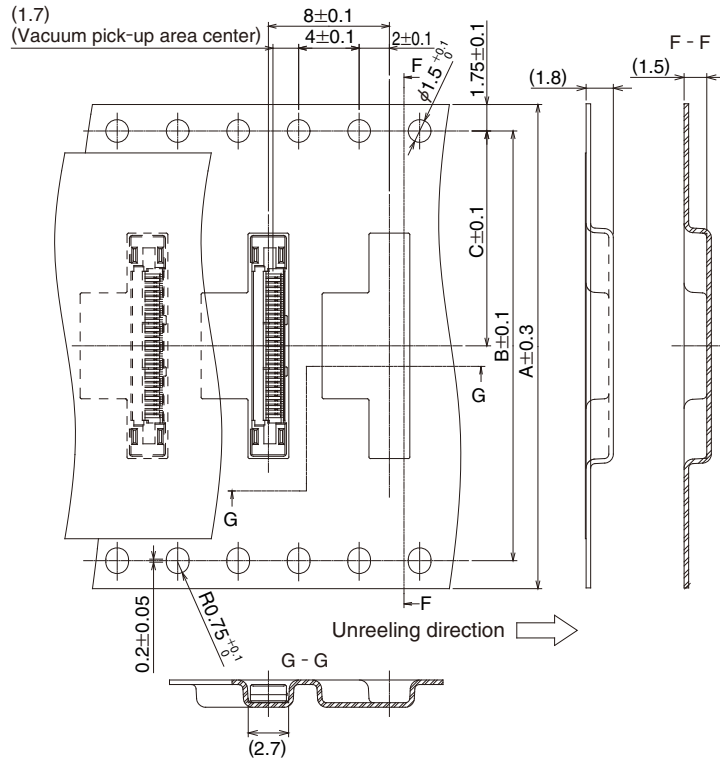

● Reel Dimensions

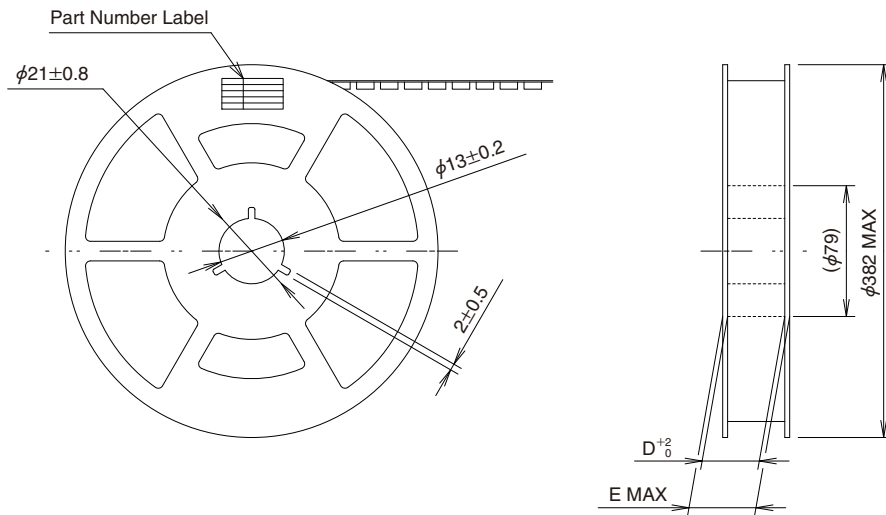

All dimensions: mm

Part Number	CL No.	Number of Contacts	A	B	C	D	E
DF38-30P-0.3SD(51)	662-4506-7-51	30	32	28.4	14.2	32.4	38.4
DF38-32P-0.3SD(51)	662-4027-4-51	32	32	28.4	14.2	32.4	38.4
DF38-40P-0.3SD(51)	662-4502-6-51	40	32	28.4	14.2	32.4	38.4

■ Extraction tool

For details about the extraction tool, please contact your Hirose sales representative.

■ Usage Recommendations

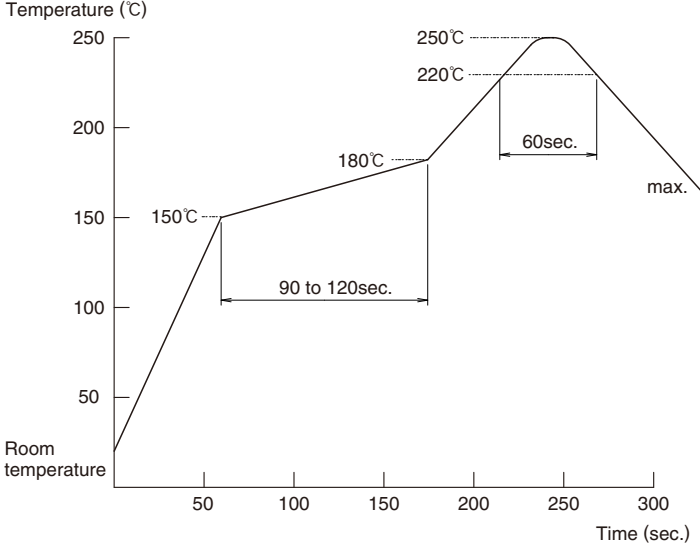
<p>1. Recommended temperature profile</p>	 <p>Solder composition: Paste, 96.5%Sn/3.0%Ag/0.5%Cu</p> <p>Note 1: Up to 2 cycles of Reflow soldering are possible under the same conditions, provided that there is a return to normal temperature between the first and second cycle.</p> <p>Note 2: The temperature profile indicates the board surface temperature at the point of contacts with the connector terminals.</p>
<p>2. Recommended manual soldering</p>	<p>Manual soldering: 350°C for 3 seconds Do NOT use flux compound when manual soldering.</p>
<p>3. Recommended screen thickness and open area ratio (Pattern area ratio)</p>	<p>Thickness: 0.1 mm Open area ratio: Lead terminal: 80% Ground terminal: 100%</p>
<p>4. Board warpage</p>	<p>Maximum of 0.02mm at the connector center, with both ends of the connector as reference points.</p>
<p>5. Cleaning conditions</p>	<p>Refer to “Nylon Connector Use Handbook”.</p>
<p>6. Precautions</p>	<ul style="list-style-type: none"> * Mating and un-mating of the connectors when not soldered on the boards is not recommended as this may cause deformation of the terminals, damage to the contacts or insulators. * When mating/un-mating do not twist or lift by the corners. Apply the forces evenly across the entire length and width of the connectors taking care NOT to damage or deform soldered terminations. * Slight discoloration on the insulating materials will not affect form, fit or function of the connectors.

Precautions

Precautions

■ Mating

Mate the plug with the receptacle by pressing straight against the entire plug surface.
Do NOT un-mate the plug while holding by the terminated cable.

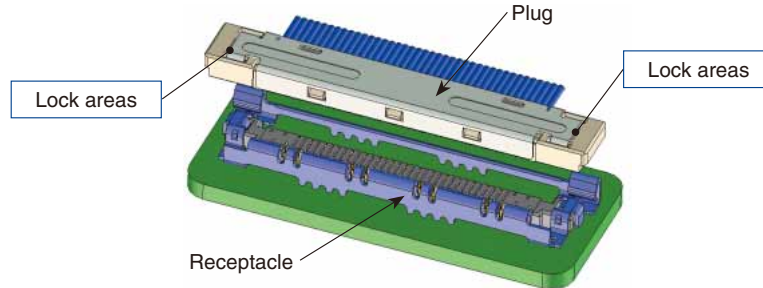

■ Un-mating

Use a dedicated extraction tool to un-mate the plug. Insert the tool under either end of the plug (clearance) and pull straight up as illustrated.
Do NOT un-mate the plug while holding by the terminated cable.

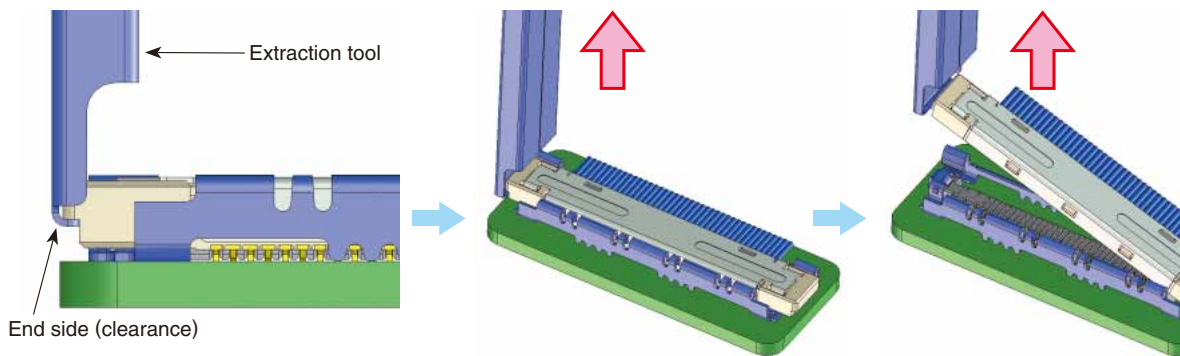

■ Routing of the fine coaxial cable after termination

Allow sufficient clearance between the plug and the fine coaxial cable to avoid sharp bend, excessive twist or pull forces applied to the connector.

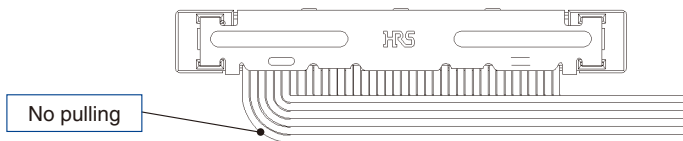

■ Other

- Do NOT mate / un-mate the connectors when receptacle is not mounted on the board.
- Different production lots may exhibit different shades of the insulator materials. No affect on form, fit or function of the connectors.
- Rework of the soldered terminations on the board-mounted receptacles is not possible.
- Sides of the metal cover protrude over the termination areas.
- Do not mate / un-mate the connectors when receptacle is not mounted on the board.

USA:

HIROSE ELECTRIC (U.S.A.), INC. Headquarters
 2688 Westhills Court, Simi Valley, CA 93065-6235
 Phone : +1-805-522-7958
 Fax : +1-805-522-3217
<http://www.hiroseusa.com>

USA:

HIROSE ELECTRIC (U.S.A.), INC. San Jose Office
 3255 Scott Boulevard, Building 7, Suite 101
 Santa Clara, CA 95054
 Phone : +1-408-253-9640
 Fax : +1-408-253-9641
<http://www.hiroseusa.com>

USA:

HIROSE ELECTRIC (U.S.A.), INC. Detroit Office (Automotive)
 37677 Professional Center Drive, Suite #100C
 Livonia, MI 48154
 Phone : +1-734-542-9963
 Fax : +1-734-542-9964
<http://www.hiroseusa.com>

THE NETHERLANDS:

HIROSE ELECTRIC EUROPE B.V.
 Hogehillweg #8 1101 CC Amsterdam Z-O
 Phone : +31-20-6557460
 Fax : +31-20-6557469
<http://www.hiroseeurope.com>

GERMANY:

HIROSE ELECTRIC EUROPE B.V. German Branch
 Herzog-Carl-Strasse 4 D-73760 Ostfildern
 (Scharnhauser Park)
 Phone : +49-711-4560-02-1
 Fax : +49-711-4560-02-299
<http://www.hirose.de>

UNITED KINGDOM:

HIROSE ELECTRIC EUROPE B.V. UK Branch
 22 Vincent Avenue, Crownhill Business
 Centre, Crownhill, Milton Keynes, MK8 0AB
 Phone : +44-1908-305750
 Fax : +44-1908-305768
<http://www.hirose.co.uk>

CHINA:

HIROSE ELECTRIC TRADING (SHANGHAI) CO., LTD.
 1601, Henderson Metropolitan, NO.300, East Nanjing
 Road, Huangpu District, Shanghai, China 200001
 Phone : +86-21-6391-3355
 Fax : +86-21-6391-3335
<http://www.hirose-china.com.cn>

CHINA:

HIROSE ELECTRIC TRADING (SHANGHAI) CO., LTD. Beijing Branch
 A1001, Ocean International Center, Building 56# East 4th
 Ring Middle Road, Chao Yang District, Beijing, 100025
 Phone : +86-10-5165-9332
 Fax : +86-10-5908-1381
<http://www.hirose-china.com.cn>

CHINA:

HIROSE ELECTRIC TECHNOLOGIES (SHENZHEN) CO., LTD.
 Room 09-13, 19/F, Office Tower Shun Hing Square, Di Wang Commercial Centre
 5002, ShenNanDong Road, ShenZhen City, Guangdong Province, 518008
 Phone : +86-755-8207-0851
 Fax : +86-755-8207-0873
<http://www.hirose-china.com.cn>

HONG KONG:

HIROSE ELECTRIC HONGKONG TRADING CO., LTD.
 Room 1001, West Wing, Tsim Sha Tsui Centre, 66
 Mody Road, Tsim Sha Tsui East, Kowloon, Hong Kong
 Phone : +852-2803-5338
 Fax : +852-2591-6560
<http://www.hirose-hongkong.com.hk>

TAIWAN:

HIROSE ELECTRIC TAIWAN CO., LTD.
 103 8F, No.87, Zhengzhou Rd., Taipei
 Phone : +886-2-2555-7377
 Fax : +886-2-2555-7350
<http://www.hirose-taiwan.com.tw>

KOREA:

HIROSE KOREA CO., LTD.
 1261-10, Jeoungwhang-Dong, Shihung-City,
 Kyunggi-Do 429-450
 Phone : +82-31-496-7000, 7124
 Fax : +82-31-496-7100
<http://www.hirose.co.kr>

SINGAPORE:

HIROSE ELECTRIC SINGAPORE PTE. LTD.
 10 Anson Road #26-1 International Plaza
 079903
 Phone : +65-6324-6113
 Fax : +65-6324-6123
<http://www.hirose-singapore.com.sg>

INDIA:

HIROSE ELECTRIC SINGAPORE PTE. LTD. Bangalore Liaison office
 Unit No.03, Ground Floor, Explorer Building International Tech
 Park Whitefield Road, Bangalore 560066 Karnataka, India
 Phone : +65-6324-6113
 Fax : +65-6324-6123
<http://www.hirose-singapore.com.sg>

INDIA:

HIROSE ELECTRIC SINGAPORE PTE. LTD Delhi Liaison Office
 Suite No. 606 5th Floor SB Tower 1A/1 Sector
 16 A Filmcity Noida 201301 Uttar Pradesh-India
 Phone : +91-120-4804917
 Fax : +91-120-4804949
<http://www.hirose.com/sg/>

MALAYSIA:

HIROSE ELECTRIC SINGAPORE PTE. LTD (Representative office)
 1-10-07, Suntech @ Penang Cybercity (1164), Lintang
 Mayang Pasir 3, 11950, Bayan Baru, Penang, Malaysia.
 Phone : +604-619-2564
 Fax : +604-619-2574
<http://www.hirose.com/sg/>



HIROSE ELECTRIC CO.,LTD.

6-3, Nakagawa Chuoh-2-Chome, Tsuzuki-Ku, Yokohama-Shi 224-8540, JAPAN
 TEL: +81-45-620-3526 Fax: +81-45-591-3726
<http://www.hirose.com>
<http://www.hirose-connectors.com>

Looking for pricing, stock, or lifecycle information?

Click below to explore more details on WIN SOURCE:

- [View DF38A-30S-0.3V\(51\) on WIN SOURCE](#)
- [Hirose Electric Co Ltd Information](#)

Optimize Your Supply Chain with WIN SOURCE Solutions

- ✓ Global Sourcing Solution
- ✓ Obsolete Management
- ✓ Cost Control Management
- ✓ Shortage Management
- ✓ Alternative Solution
- ✓ Excess Inventory Management