



**THE DATASHEET OF  
NCV33172DR2G**



# MC33171, 2, 4, NCV33172, 4

## Single Supply 3.0 V to 44 V, Low Power Operational Amplifiers

Quality bipolar fabrication with innovative design concepts are employed for the MC33171/72/74, NCV33172/74 series of monolithic operational amplifiers. These devices operate at 180  $\mu$ A per amplifier and offer 1.8 MHz of gain bandwidth product and 2.1 V/ $\mu$ s slew rate without the use of JFET device technology. Although this series can be operated from split supplies, it is particularly suited for single supply operation, since the common mode input voltage includes ground potential ( $V_{EE}$ ). With a Darlington input stage, these devices exhibit high input resistance, low input offset voltage and high gain. The all NPN output stage, characterized by no deadband crossover distortion and large output voltage swing, provides high capacitance drive capability, excellent phase and gain margins, low open loop high frequency output impedance and symmetrical source/sink AC frequency response.

The MC33171/72/74, NCV33172/74 are specified over the industrial/automotive temperature ranges. The complete series of single, dual and quad operational amplifiers are available in plastic as well as the surface mount packages.

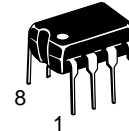
### Features

- Low Supply Current: 180  $\mu$ A (Per Amplifier)
- Wide Supply Operating Range: 3.0 V to 44 V or  $\pm 1.5$  V to  $\pm 22$  V
- Wide Input Common Mode Range, Including Ground ( $V_{EE}$ )
- Wide Bandwidth: 1.8 MHz
- High Slew Rate: 2.1 V/ $\mu$ s
- Low Input Offset Voltage: 2.0 mV
- Large Output Voltage Swing:  $-14.2$  V to  $+14.2$  V (with  $\pm 15$  V Supplies)
- Large Capacitance Drive Capability: 0 pF to 500 pF
- Low Total Harmonic Distortion: 0.03%
- Excellent Phase Margin: 60°
- Excellent Gain Margin: 15 dB
- Output Short Circuit Protection
- ESD Diodes Provide Input Protection for Dual and Quad
- NCV Prefix for Automotive and Other Applications Requiring Unique Site and Control Change Requirements; AEC-Q100 Qualified and PPAP Capable
- These Devices are Pb-Free, Halogen Free/BFR Free and are RoHS Compliant



ON Semiconductor®

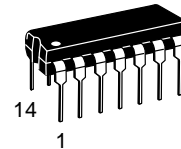
[www.onsemi.com](http://www.onsemi.com)



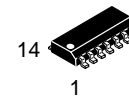
PDIP-8  
P SUFFIX  
CASE 626



SO-8  
D, VD SUFFIX  
CASE 751



PDIP-14  
P, VP SUFFIX  
CASE 646



SO-14  
D, VD SUFFIX  
CASE 751A



TSSOP-14  
DTB SUFFIX  
CASE 948G

### ORDERING INFORMATION

See detailed ordering and shipping information in the package dimensions section on page 9 of this data sheet.

### DEVICE MARKING INFORMATION

See general marking information in the device marking section on page 10 of this data sheet.

# MC33171, 2, 4, NCV33172, 4

## PIN CONNECTIONS

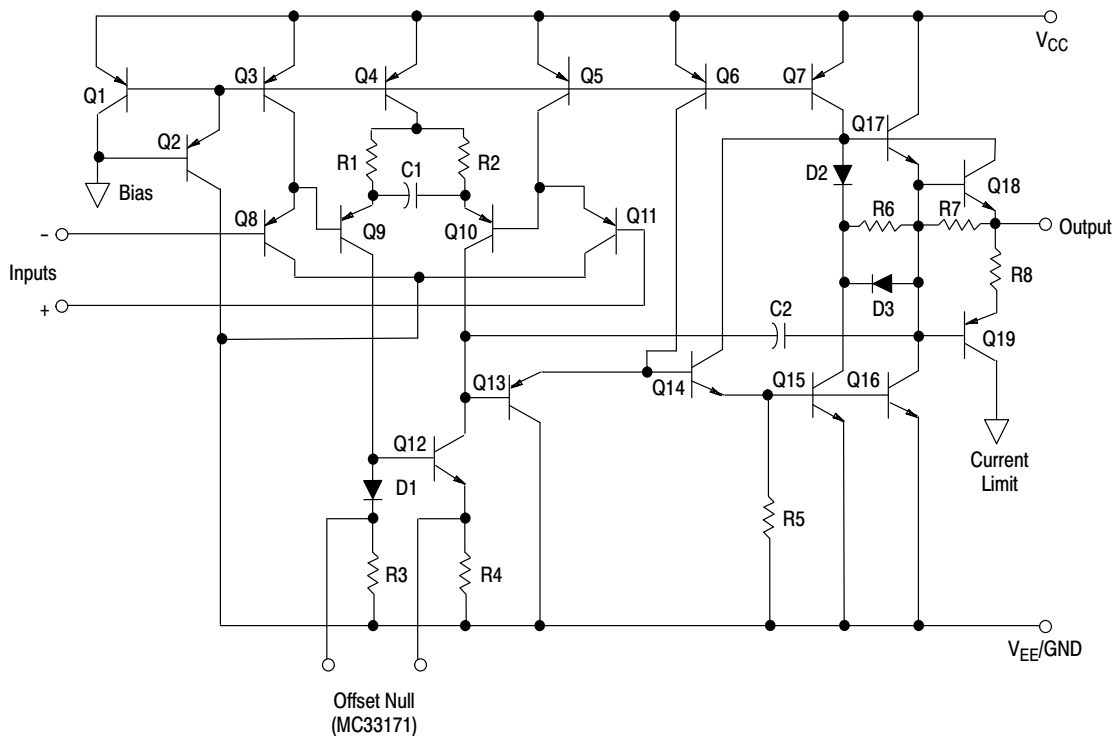
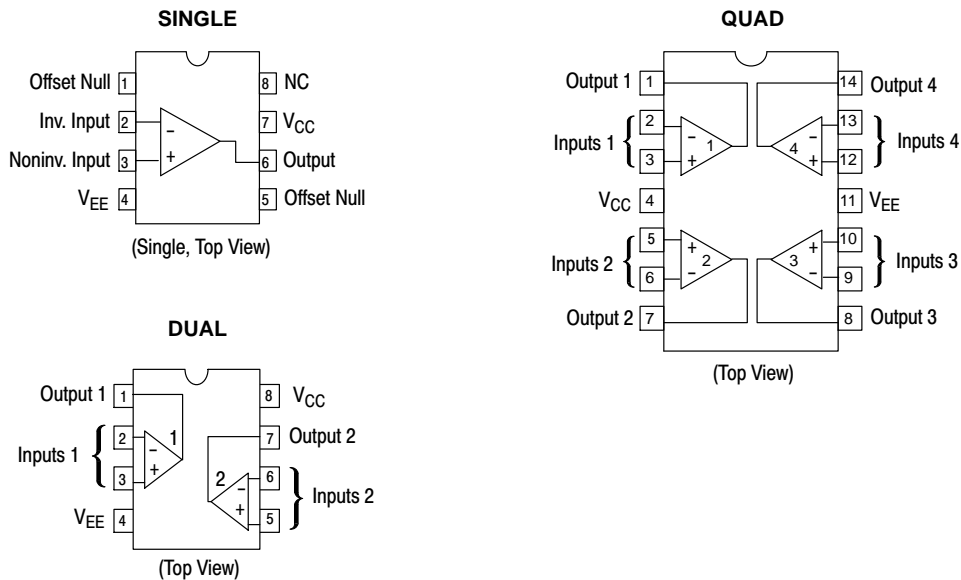


Figure 1. Representative Schematic Diagram (Each Amplifier)

# MC33171, 2, 4, NCV33172, 4

## MAXIMUM RATINGS

Rating	Symbol	Value	Unit
Supply Voltage	$V_{CC}/V_{EE}$	$\pm 22$	V
Input Differential Voltage Range	$V_{IDR}$	(Note 1)	V
Input Voltage Range	$V_{IR}$	(Note 1)	V
Output Short Circuit Duration (Note 2)	$t_{SC}$	Indefinite	sec
Operating Ambient Temperature Range	$T_A$	(Note 3)	$^{\circ}\text{C}$
Operating Junction Temperature	$T_J$	+150	$^{\circ}\text{C}$
Storage Temperature Range	$T_{stg}$	-65 to +150	$^{\circ}\text{C}$

Stresses exceeding those listed in the Maximum Ratings table may damage the device. If any of these limits are exceeded, device functionality should not be assumed, damage may occur and reliability may be affected.

## DC ELECTRICAL CHARACTERISTICS ( $V_{CC} = +15\text{ V}$ , $V_{EE} = -15\text{ V}$ , $R_L$ connected to ground, $T_A = +25^{\circ}\text{C}$ , unless otherwise noted.)

Characteristics	Symbol	Min	Typ	Max	Unit
Input Offset Voltage ( $V_{CM} = 0\text{ V}$ ) $V_{CC} = +15\text{ V}$ , $V_{EE} = -15\text{ V}$ , $T_A = +25^{\circ}\text{C}$ $V_{CC} = +5.0\text{ V}$ , $V_{EE} = 0\text{ V}$ , $T_A = +25^{\circ}\text{C}$ $V_{CC} = +15\text{ V}$ , $V_{EE} = -15\text{ V}$ , $T_A = T_{low}$ to $T_{high}$ (Note 3)	$V_{IO}$	-	2.0 2.5 -	4.5 5.0 6.5	mV
Average Temperature Coefficient of Offset Voltage	$\Delta V_{IO}/\Delta T$	-	10	-	$\mu\text{V}/^{\circ}\text{C}$
Input Bias Current ( $V_{CM} = 0\text{ V}$ ) $T_A = +25^{\circ}\text{C}$ $T_A = T_{low}$ to $T_{high}$ (Note 3)	$I_{IB}$	-	20	100 200	nA
Input Offset Current ( $V_{CM} = 0\text{ V}$ ) $T_A = +25^{\circ}\text{C}$ $T_A = T_{low}$ to $T_{high}$ (Note 3)	$I_{IO}$	-	5.0	20 40	nA
Large Signal Voltage Gain ( $V_O = \pm 10\text{ V}$ , $R_L = 10\text{ k}$ ) $T_A = +25^{\circ}\text{C}$ $T_A = T_{low}$ to $T_{high}$ (Note 3)	$A_{VOL}$	50 25	500	-	V/mV
Output Voltage Swing $V_{CC} = +5.0\text{ V}$ , $V_{EE} = 0\text{ V}$ , $R_L = 10\text{ k}$ , $T_A = +25^{\circ}\text{C}$ $V_{CC} = +15\text{ V}$ , $V_{EE} = -15\text{ V}$ , $R_L = 10\text{ k}$ , $T_A = +25^{\circ}\text{C}$ $V_{CC} = +15\text{ V}$ , $V_{EE} = -15\text{ V}$ , $R_L = 10\text{ k}$ , $T_A = T_{low}$ to $T_{high}$ (Note 3)	$V_{OH}$	3.5 13.6 13.3	4.3 14.2	-	V
$V_{CC} = +5.0\text{ V}$ , $V_{EE} = 0\text{ V}$ , $R_L = 10\text{ k}$ , $T_A = +25^{\circ}\text{C}$ $V_{CC} = +15\text{ V}$ , $V_{EE} = -15\text{ V}$ , $R_L = 10\text{ k}$ , $T_A = +25^{\circ}\text{C}$ $V_{CC} = +15\text{ V}$ , $V_{EE} = -15\text{ V}$ , $R_L = 10\text{ k}$ , $T_A = T_{low}$ to $T_{high}$ (Note 3)	$V_{OL}$	-	0.05 -14.2	0.15 -13.6 -13.3	
Output Short Circuit ( $T_A = +25^{\circ}\text{C}$ ) Input Overdrive = 1.0 V, Output to Ground Source Sink	$I_{SC}$	3.0 15	5.0 27	-	mA
Input Common Mode Voltage Range $T_A = +25^{\circ}\text{C}$ $T_A = T_{low}$ to $T_{high}$ (Note 3)	$V_{ICR}$	$V_{EE}$ to $(V_{CC} - 1.8)$ $V_{EE}$ to $(V_{CC} - 2.2)$			V
Common Mode Rejection Ratio ( $R_S \leq 10\text{ k}$ ), $T_A = +25^{\circ}\text{C}$	CMRR	80	90	-	dB
Power Supply Rejection Ratio ( $R_S = 100\ \Omega$ ), $T_A = +25^{\circ}\text{C}$	PSRR	80	100	-	dB
Power Supply Current (Per Amplifier) $V_{CC} = +5.0\text{ V}$ , $V_{EE} = 0\text{ V}$ , $T_A = +25^{\circ}\text{C}$ $V_{CC} = +15\text{ V}$ , $V_{EE} = -15\text{ V}$ , $T_A = +25^{\circ}\text{C}$ $V_{CC} = +15\text{ V}$ , $V_{EE} = -15\text{ V}$ , $T_A = T_{low}$ to $T_{high}$ (Note 3)	$I_D$	-	180 220	250 250 300	$\mu\text{A}$

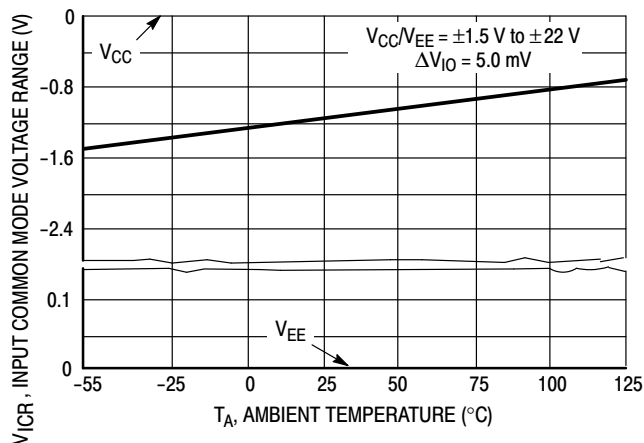
- Either or both input voltages must not exceed the magnitude of  $V_{CC}$  or  $V_{EE}$ .
- Power dissipation must be considered to ensure maximum junction temperature ( $T_J$ ) is not exceeded.
- MC3317x  $T_{low} = -40^{\circ}\text{C}$   $T_{high} = +85^{\circ}\text{C}$   
MC3317xV, NCV3317x  $T_{low} = -40^{\circ}\text{C}$   $T_{high} = +125^{\circ}\text{C}$

# MC33171, 2, 4, NCV33172, 4

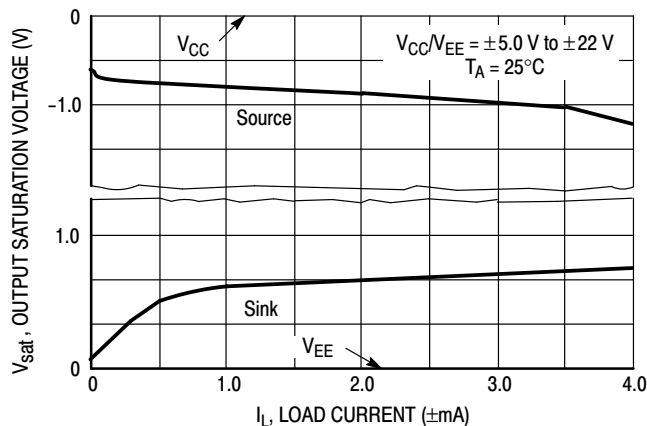
**AC ELECTRICAL CHARACTERISTICS** ( $V_{CC} = +15\text{ V}$ ,  $V_{EE} = -15\text{ V}$ ,  $R_L$  connected to ground,  $T_A = +25^\circ\text{C}$ , unless otherwise noted.)

Characteristics	Symbol	Min	Typ	Max	Unit
Slew Rate ( $V_{in} = -10\text{ V to } +10\text{ V}$ , $R_L = 10\text{ k}$ , $C_L = 100\text{ pF}$ ) $A_V +1$ $A_V -1$	SR	1.6 -	2.1 2.1	- -	$\text{V}/\mu\text{s}$
Gain Bandwidth Product ( $f = 100\text{ kHz}$ )	GBW	1.4	1.8	-	MHz
Power Bandwidth $A_V = +1.0$ , $R_L = 10\text{ k}$ , $V_O = 20\text{ V}_{pp}$ , THD = 5%	BWp	-	35	-	kHz
Phase Margin $R_L = 10\text{ k}$ $R_L = 10\text{ k}$ , $C_L = 100\text{ pF}$	$\phi_m$	- -	60 45	- -	Deg
Gain Margin $R_L = 10\text{ k}$ $R_L = 10\text{ k}$ , $C_L = 100\text{ pF}$	$A_m$	- -	15 5.0	- -	dB
Equivalent Input Noise Voltage $R_S = 100\ \Omega$ , $f = 1.0\text{ kHz}$	$e_n$	-	32	-	$\text{nV}/\sqrt{\text{Hz}}$
Equivalent Input Noise Current ( $f = 1.0\text{ kHz}$ )	$I_n$	-	0.2	-	$\text{pA}/\sqrt{\text{Hz}}$
Differential Input Resistance $V_{cm} = 0\text{ V}$	$R_{in}$	-	300	-	$\text{M}\Omega$
Input Capacitance	$C_{in}$	-	0.8	-	pF
Total Harmonic Distortion $A_V = +10$ , $R_L = 10\text{ k}$ , $2.0\text{ V}_{pp} \leq V_O \leq 20\text{ V}_{pp}$ , $f = 10\text{ kHz}$	THD	-	0.03	-	%
Channel Separation ( $f = 10\text{ kHz}$ )	CS	-	120	-	dB
Open Loop Output Impedance ( $f = 1.0\text{ MHz}$ )	$z_o$	-	100	-	$\Omega$

Product parametric performance is indicated in the Electrical Characteristics for the listed test conditions, unless otherwise noted. Product performance may not be indicated by the Electrical Characteristics if operated under different conditions.



**Figure 2. Input Common Mode Voltage Range versus Temperature**



**Figure 3. Split Supply Output Saturation versus Load Current**

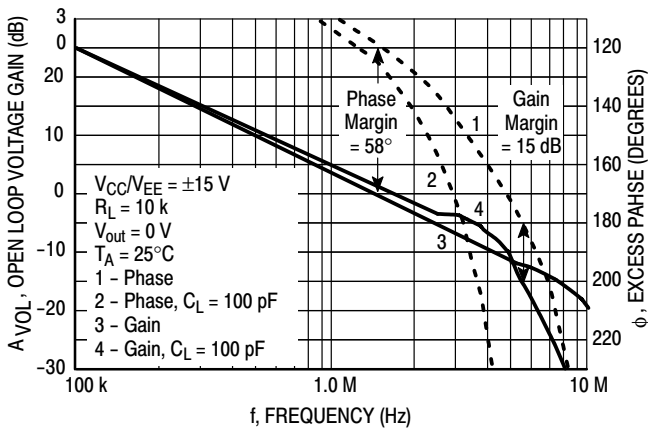


Figure 4. Open Loop Voltage Gain and Phase versus Frequency

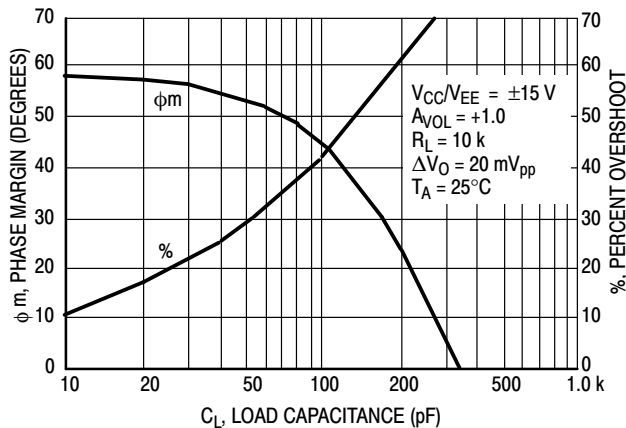


Figure 5. Phase Margin and Percent Overshoot versus Load Capacitance

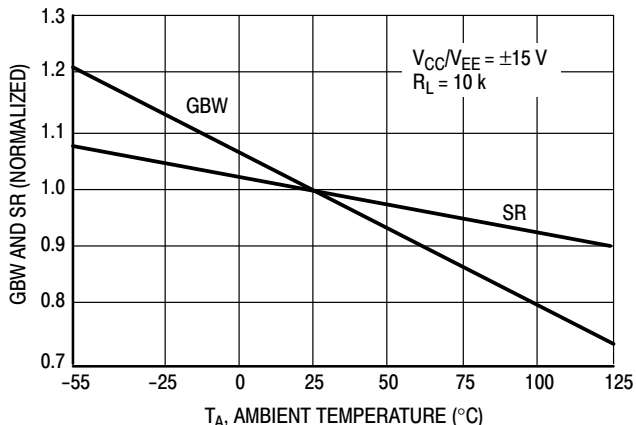


Figure 6. Normalized Gain Bandwidth Product and Slew Rate versus Temperature

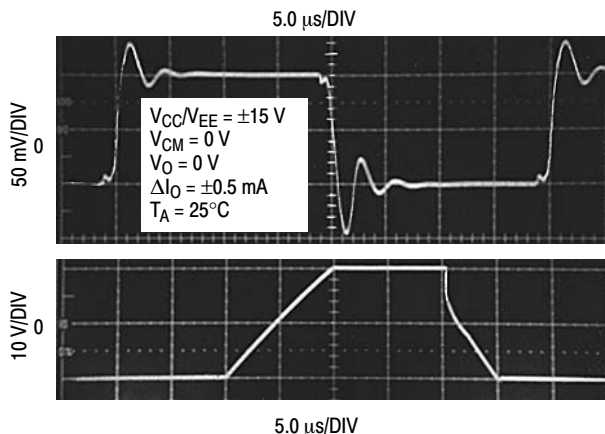


Figure 7. Small and Large Signal Transient Response

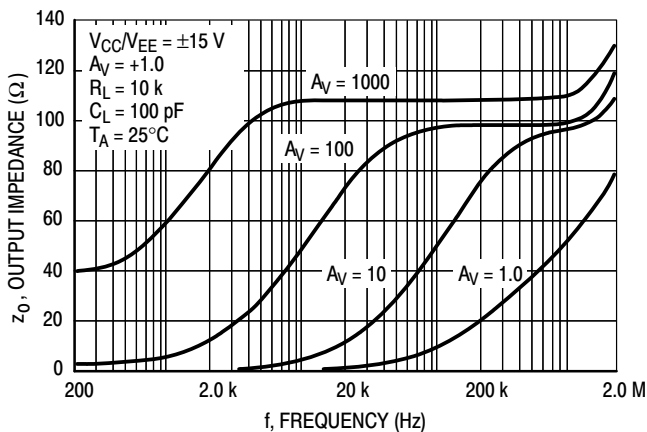


Figure 8. Output Impedance and Frequency

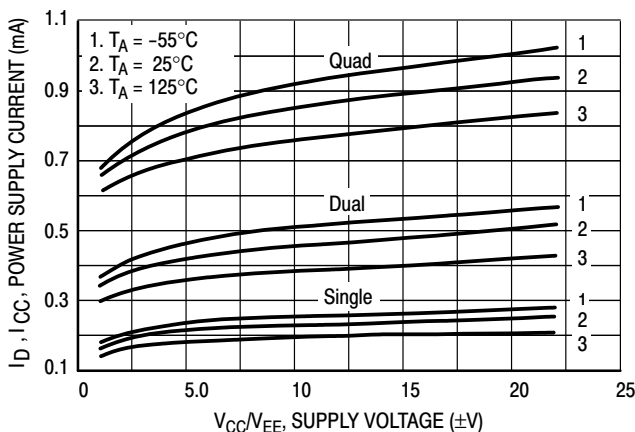


Figure 9. Supply Current versus Supply Voltage

## APPLICATIONS INFORMATION – CIRCUIT DESCRIPTION/PERFORMANCE FEATURES

Although the bandwidth, slew rate, and settling time of the MC33171/72/74 amplifier family is similar to low power op amp products utilizing JFET input devices, these amplifiers offer additional advantages as a result of the PNP transistor differential inputs and an all NPN transistor output stage.

Because the input common mode voltage range of this input stage includes the  $V_{EE}$  potential, single supply operation is feasible to as low as 3.0 V with the common mode input voltage at ground potential.

The input stage also allows differential input voltages up to  $\pm 44$  V, provided the maximum input voltage range is not exceeded. Specifically, the input voltages must range between  $V_{CC}$  and  $V_{EE}$  supply voltages as shown by the maximum rating table. In practice, although *not recommended*, the input voltages can exceed the  $V_{CC}$  voltage by approximately 3.0 V and decrease below the  $V_{EE}$  voltage by 0.3 V without causing product damage, although output phase reversal may occur. It is also possible to source up to 5.0 mA of current from  $V_{EE}$  through either inputs' clamping diode without damage or latching, but phase reversal may again occur. If at least one input is within the common mode input voltage range and the other input is within the maximum input voltage range, no phase reversal will occur. If both inputs exceed the upper common mode input voltage limit, the output will be forced to its lowest voltage state.

Since the input capacitance associated with the small geometry input device is substantially lower (0.8 pF) than that of a typical JFET (3.0 pF), the frequency response for a given input source resistance is greatly enhanced. This becomes evident in D-to-A current to voltage conversion applications where the feedback resistance can form a pole with the input capacitance of the op amp. This input pole creates a 2nd Order system with the single pole op amp and is therefore detrimental to its settling time. In this context, lower input capacitance is desirable especially for higher values of feedback resistances (lower current DACs). This input pole can be compensated for by creating a feedback zero with a capacitance across the feedback resistance, if necessary, to reduce overshoot. For 10 k $\Omega$  of feedback resistance, the MC33171/72/74 family can typically settle to within 1/2 LSB of 8 bits in 4.2  $\mu$ s, and within 1/2 LSB of 12 bits in 4.8  $\mu$ s for a 10 V step. In a standard inverting unity gain fast settling configuration, the symmetrical slew rate is typically  $\pm 2.1$  V/ $\mu$ s. In the classic noninverting unity gain configuration the typical output positive slew rate is also 2.1 V/ $\mu$ s, and the corresponding negative slew rate will usually exceed the positive slew rate as a function of the fall time of the input waveform.

The all NPN output stage, shown in its basic form on the equivalent circuit schematic, offers unique advantages over the more conventional NPN/PNP transistor Class AB output stage. A 10 k $\Omega$  load resistance can typically swing within

0.8 V of the positive rail ( $V_{CC}$ ) and negative rail ( $V_{EE}$ ), providing a 28.4 V<sub>pp</sub> swing from  $\pm 15$  V supplies. This large output swing becomes most noticeable at lower supply voltages.

The positive swing is limited by the saturation voltage of the current source transistor Q7, the  $V_{BE}$  of the NPN pull-up transistor Q17, and the voltage drop associated with the short circuit resistance, R5. For sink currents less than 0.4 mA, the negative swing is limited by the saturation voltage of the pull-down transistor Q15, and the voltage drop across R4 and R5. For small valued sink currents, the above voltage drops are negligible, allowing the negative swing voltage to approach within millivolts of  $V_{EE}$ . For sink currents ( $> 0.4$  mA), diode D3 clamps the voltage across R4. Thus the negative swing is limited by the saturation voltage of Q15, plus the forward diode drop of D3 ( $\approx V_{EE} + 1.0$  V). Therefore an unprecedented peak-to-peak output voltage swing is possible for a given supply voltage as indicated by the output swing specifications.

If the load resistance is referenced to  $V_{CC}$  instead of ground for single supply applications, the maximum possible output swing can be achieved for a given supply voltage. For light load currents, the load resistance will pull the output to  $V_{CC}$  during the positive swing and the output will pull the load resistance near ground during the negative swing. The load resistance value should be much less than that of the feedback resistance to maximize pull-up capability.

Because the PNP output emitter-follower transistor has been eliminated, the MC33171/72/74 family offers a 15 mA minimum current sink capability, typically to an output voltage of ( $V_{EE} + 1.8$  V). In single supply applications the output can directly source or sink base current from a common emitter NPN transistor for current switching applications.

In addition, the all NPN transistor output stage is inherently faster than PNP types, contributing to the bipolar amplifier's improved gain bandwidth product. The associated high frequency low output impedance (200  $\Omega$  typ @ 1.0 MHz) allows capacitive drive capability from 0 pF to 400 pF without oscillation in the noninverting unity gain configuration. The 60° phase margin and 15 dB gain margin, as well as the general gain and phase characteristics, are virtually independent of the source/sink output swing conditions. This allows easier system phase compensation, since output swing will not be a phase consideration. The AC characteristics of the MC33171/72/74 family also allow excellent active filter capability, especially for low voltage single supply applications.

Although the single supply specification is defined at 5.0 V, these amplifiers are functional to at least 3.0 V @ 25°C. However slight changes in parametrics such as bandwidth, slew rate, and DC gain may occur.

## MC33171, 2, 4, NCV33172, 4

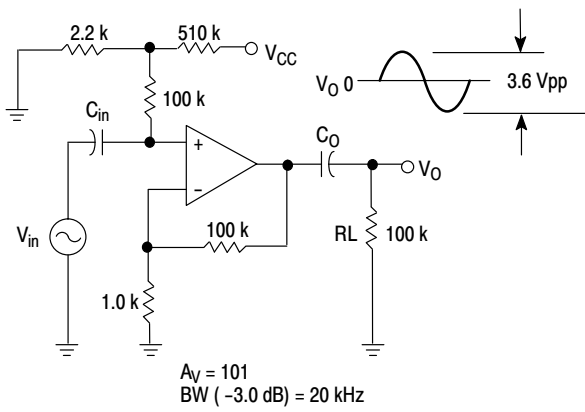
If power to this integrated circuit is applied in reverse polarity, or if the IC is installed backwards in a socket, large unlimited current surges will occur through the device that may result in device destruction.

As usual with most high frequency amplifiers, proper lead dress, component placement and PC board layout should be exercised for optimum frequency performance. For example, long unshielded input or output leads may result in unwanted input/output coupling. In order to preserve the relatively low input capacitance associated with these amplifiers, resistors connected to the inputs should be immediately adjacent to the input pin to minimize additional stray input capacitance. This not only minimizes the input

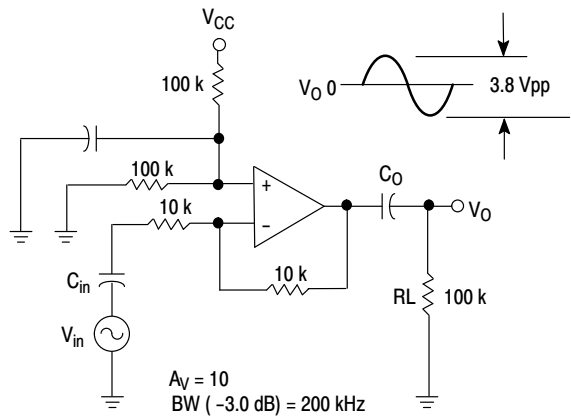
pole for optimum frequency response, but also minimizes extraneous “pick up” at this node. Supply decoupling with adequate capacitance immediately adjacent to the supply pin is also important, particularly over temperature, since many types of decoupling capacitors exhibit great impedance changes over temperature.

The output of any one amplifier is current limited and thus protected from a direct short to ground. However, under such conditions, it is important not to allow the device to exceed the maximum junction temperature rating. Typically for  $\pm 15$  V supplies, any one output can be shorted continuously to ground without exceeding the maximum temperature rating.

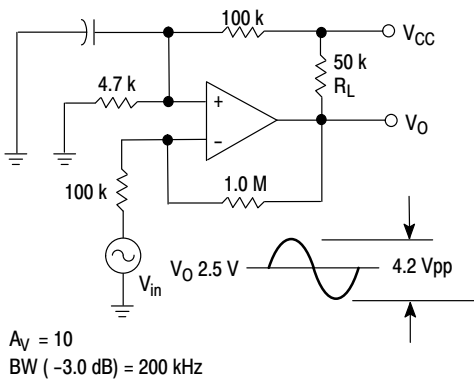
# MC33171, 2, 4, NCV33172, 4



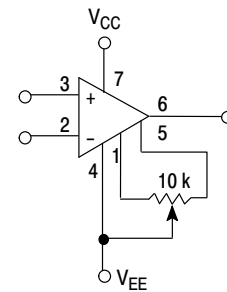
**Figure 10. AC Coupled Noninverting Amplifier with Single +5.0 V Supply**



**Figure 11. AC Coupled Inverting Amplifier with Single +5.0 V Supply**

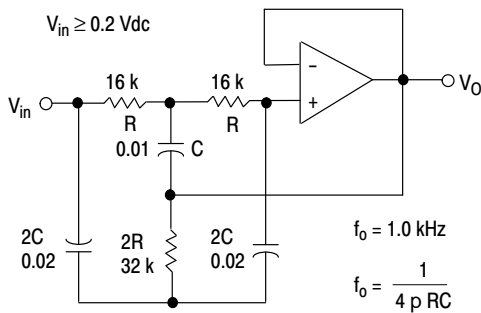


**Figure 12. DC Coupled Inverting Amplifier Maximum Output Swing with Single +5.0 V Supply**

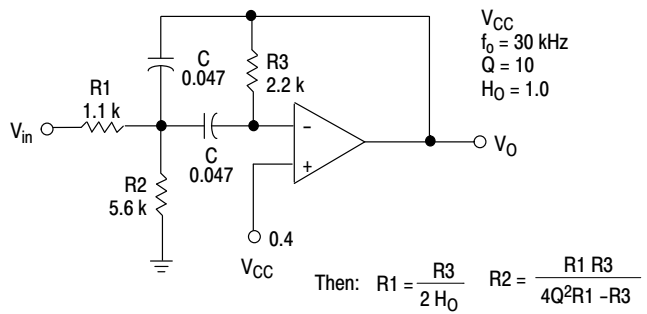


Offset Nulling range is approximately  $\pm 80 \text{ mV}$  with a 10 k potentiometer, MC33171 only.

**Figure 13. Offset Nulling Circuit**



**Figure 14. Active High-Q Notch Filter**



Given  $f_0$  = center frequency  
 $A_0$  = Gain at center frequency  
 Choose Value  $f_0$ ,  $Q$ ,  $A_0$ ,  $C$   
 For less than 10% error for operational amplifier, where  $f_0$  and  $GBW$  are expressed in Hz.

$R_3 = \frac{Q}{\pi f_0 C}$      $\frac{Q_0 f_0}{GBW} < 0.1$

**Figure 15. Active Bandpass Filter**

## MC33171, 2, 4, NCV33172, 4

### ORDERING INFORMATION

Op Amp Function	Device	Operating Temperature Range	Package	Shipping <sup>†</sup>
Single	MC33171DG	$T_A = -40^\circ \text{ to } +85^\circ \text{C}$	SO-8 (Pb-Free)	98 Units/Rail
	MC33171DR2G		SO-8 (Pb-Free)	2500 / Tape & Reel
	MC33171PG		PDIP (Pb-Free)	50 Units/Rail
Dual	MC33172DG	$T_A = -40^\circ \text{ to } +85^\circ \text{C}$	SO-8 (Pb-Free)	98 Units/Rail
	MC33172DR2G		SO-8 (Pb-Free)	2500 / Tape & Reel
	MC33172PG		PDIP (Pb-Free)	50 Units/Rail
	MC33172VDG	$T_A = -40^\circ \text{ to } +125^\circ \text{C}$	SO-8 (Pb-Free)	98 Units/Rail
	MC33172VDR2G		SO-8 (Pb-Free)	2500 / Tape & Reel
	NCV33172DR2G*		SO-8 (Pb-Free)	2500 / Tape & Reel
Quad	MC33174DG	$T_A = -40^\circ \text{ to } +85^\circ \text{C}$	SO-14 (Pb-Free)	55 Units/Rail
	MC33174DR2G		SO-14 (Pb-Free)	2500 / Tape & Reel
	MC33174DTBG		TSSOP-14 (Pb-Free)	96 Units/Rail
	MC33174DTBR2G		TSSOP-14 (Pb-Free)	2500 / Tape & Reel
	MC33174PG		PDIP (Pb-Free)	25 Units/Rail
	MC33174VDG	$T_A = -40^\circ \text{ to } +125^\circ \text{C}$	SO-14 (Pb-Free)	55 Units/Rail
	MC33174VDR2G		SO-14 (Pb-Free)	2500 / Tape & Reel
	MC33174VPG		PDIP (Pb-Free)	25 Units/Rail
	NCV33174DTBR2G*		TSSOP-14 (Pb-Free)	2500 / Tape & Reel

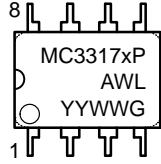
<sup>†</sup>For information on tape and reel specifications, including part orientation and tape sizes, please refer to our Tape and Reel Packaging Specifications Brochure, BRD8011/D.

\*NCV prefix for automotive and other applications requiring site and change controls.

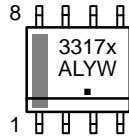
# MC33171, 2, 4, NCV33172, 4

## MARKING DIAGRAMS

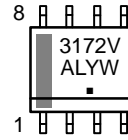
**PDIP-8**  
**P SUFFIX**  
**CASE 626**



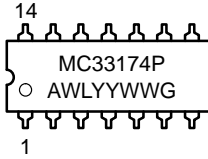
**SO-8**  
**D SUFFIX**  
**CASE 751**



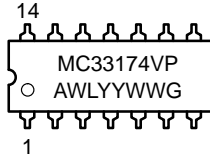
**SO-8**  
**MC33172VD**  
**NCV33172D**  
**CASE 751**



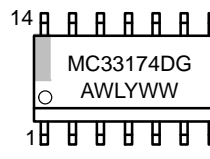
**PDIP-14**  
**P SUFFIX**  
**CASE 646**



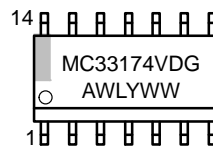
**PDIP-14**  
**VP SUFFIX**  
**CASE 646**



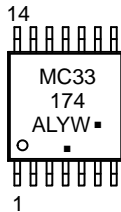
**SO-14**  
**D SUFFIX**  
**CASE 751A**



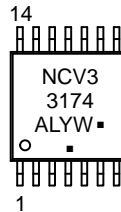
**SO-14**  
**VD SUFFIX**  
**CASE 751A**



**TSSOP-14**  
**MC33174**  
**CASE 948G**



**TSSOP-14**  
**NCV33174**  
**CASE 948G**



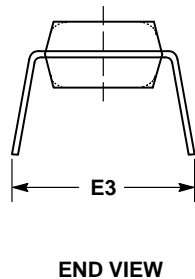
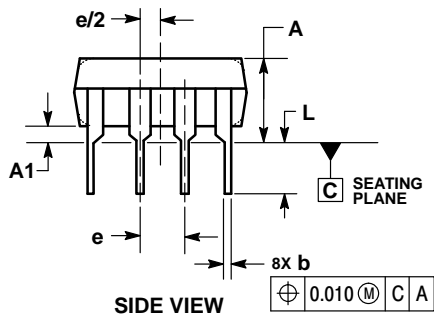
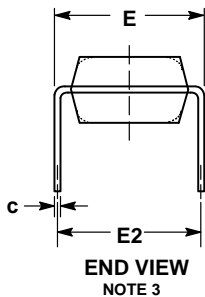
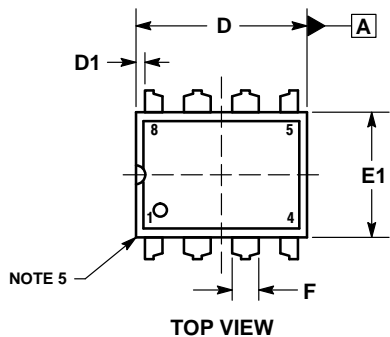
- x = 1 or 2
- A = Assembly Location
- WL, L = Wafer Lot
- YY, Y = Year
- WW, W = Work Week
- G or ■ = Pb-Free Package

(Note: Microdot may be in either location)

# MC33171, 2, 4, NCV33172, 4

## PACKAGE DIMENSIONS

### 8 LEAD PDIP CASE 626-05 ISSUE M



**NOTES:**

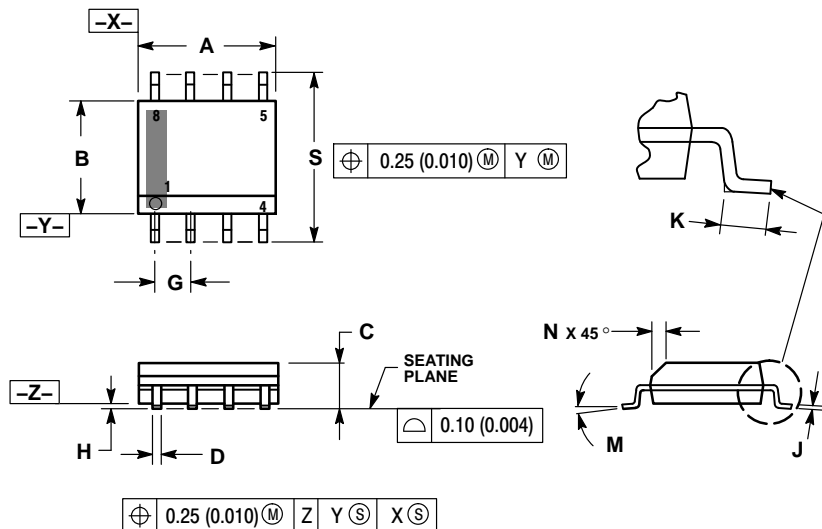
1. DIMENSIONING AND TOLERANCING PER ASME Y14.5M, 1994.
2. CONTROLLING DIMENSION: INCHES.
3. DIMENSION E IS MEASURED WITH THE LEADS RESTRAINED PARALLEL AT WIDTH E2.
4. DIMENSION E1 DOES NOT INCLUDE MOLD FLASH.
5. ROUNDED CORNERS OPTIONAL.

DIM	INCHES			MILLIMETERS		
	MIN	NOM	MAX	MIN	NOM	MAX
A	-----	-----	0.210	-----	-----	5.33
A1	0.015	-----	-----	0.38	-----	-----
b	0.014	0.018	0.022	0.35	0.46	0.56
C	0.008	0.010	0.014	0.20	0.25	0.36
D	0.355	0.365	0.400	9.02	9.27	10.02
D1	0.005	-----	-----	0.13	-----	-----
E	0.300	0.310	0.325	7.62	7.87	8.26
E1	0.240	0.250	0.280	6.10	6.35	7.11
E2	0.300 BSC			7.62 BSC		
E3	-----	-----	0.430	-----	-----	10.92
e	0.100 BSC			2.54 BSC		
L	0.115	0.130	0.150	2.92	3.30	3.81

# MC33171, 2, 4, NCV33172, 4

## PACKAGE DIMENSIONS

SOIC-8 NB  
CASE 751-07  
ISSUE AK

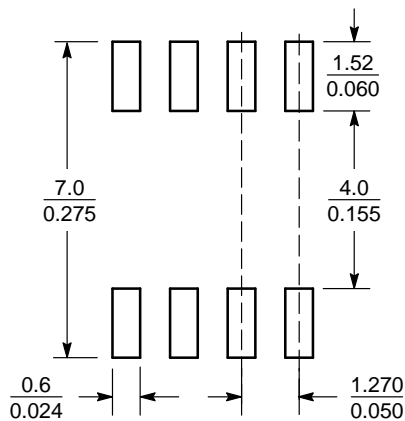


**NOTES:**

1. DIMENSIONING AND TOLERANCING PER ANSI Y14.5M, 1982.
2. CONTROLLING DIMENSION: MILLIMETER.
3. DIMENSION A AND B DO NOT INCLUDE MOLD PROTRUSION.
4. MAXIMUM MOLD PROTRUSION 0.15 (0.006) PER SIDE.
5. DIMENSION D DOES NOT INCLUDE DAMBAR PROTRUSION. ALLOWABLE DAMBAR PROTRUSION SHALL BE 0.127 (0.005) TOTAL IN EXCESS OF THE D DIMENSION AT MAXIMUM MATERIAL CONDITION.
6. 751-01 THRU 751-06 ARE OBSOLETE. NEW STANDARD IS 751-07.

DIM	MILLIMETERS		INCHES	
	MIN	MAX	MIN	MAX
A	4.80	5.00	0.189	0.197
B	3.80	4.00	0.150	0.157
C	1.35	1.75	0.053	0.069
D	0.33	0.51	0.013	0.020
G	1.27 BSC		0.050 BSC	
H	0.10	0.25	0.004	0.010
J	0.19	0.25	0.007	0.010
K	0.40	1.27	0.016	0.050
M	0°	8°	0°	8°
N	0.25	0.50	0.010	0.020
S	5.80	6.20	0.228	0.244

### SOLDERING FOOTPRINT\*



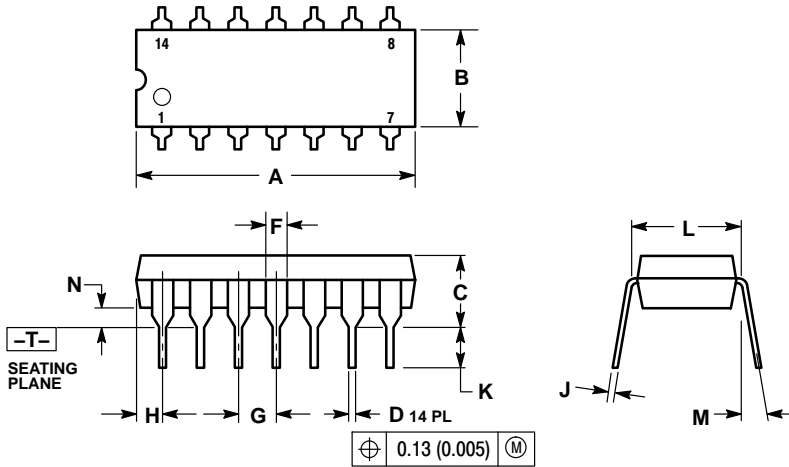
SCALE 6:1 (mm/inches)

\*For additional information on our Pb-Free strategy and soldering details, please download the ON Semiconductor Soldering and Mounting Techniques Reference Manual, SOLDERRM/D.

# MC33171, 2, 4, NCV33172, 4

## PACKAGE DIMENSIONS

PDIP-14  
CASE 646-06  
ISSUE P



NOTES:

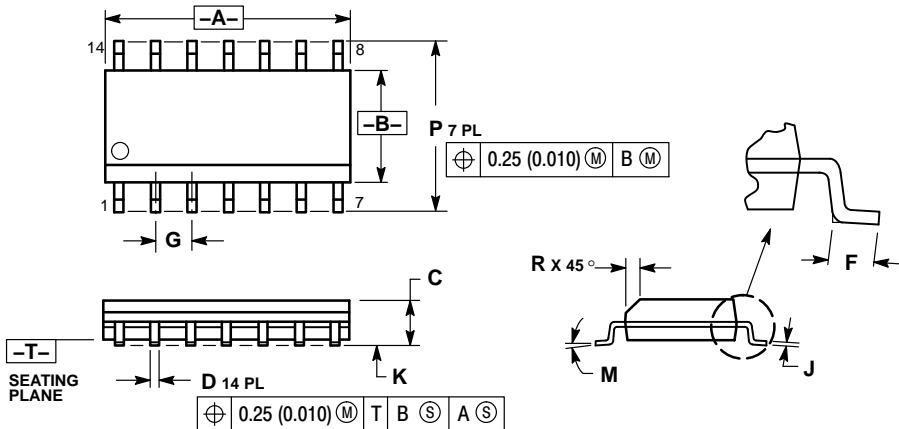
1. DIMENSIONING AND TOLERANCING PER ANSI Y14.5M, 1982.
2. CONTROLLING DIMENSION: INCH.
3. DIMENSION L TO CENTER OF LEADS WHEN FORMED PARALLEL.
4. DIMENSION B DOES NOT INCLUDE MOLD FLASH.
5. ROUNDED CORNERS OPTIONAL.

DIM	INCHES		MILLIMETERS	
	MIN	MAX	MIN	MAX
A	0.715	0.770	18.16	19.56
B	0.240	0.260	6.10	6.60
C	0.145	0.185	3.69	4.69
D	0.015	0.021	0.38	0.53
F	0.040	0.070	1.02	1.78
G	0.100 BSC		2.54 BSC	
H	0.052	0.095	1.32	2.41
J	0.008	0.015	0.20	0.38
K	0.115	0.135	2.92	3.43
L	0.290	0.310	7.37	7.87
M	---		10°	
N	0.015	0.039	0.38	1.01

# MC33171, 2, 4, NCV33172, 4

## PACKAGE DIMENSIONS

SOIC-14  
CASE 751A-03  
ISSUE J

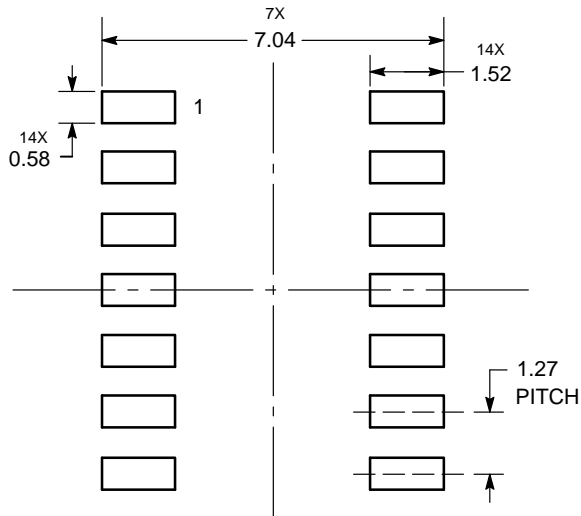


NOTES:

1. DIMENSIONING AND TOLERANCING PER ANSI Y14.5M, 1982.
2. CONTROLLING DIMENSION: MILLIMETER.
3. DIMENSIONS A AND B DO NOT INCLUDE MOLD PROTRUSION.
4. MAXIMUM MOLD PROTRUSION 0.15 (0.006) PER SIDE.
5. DIMENSION D DOES NOT INCLUDE DAMBAR PROTRUSION. ALLOWABLE DAMBAR PROTRUSION SHALL BE 0.127 (0.005) TOTAL IN EXCESS OF THE D DIMENSION AT MAXIMUM MATERIAL CONDITION.

DIM	MILLIMETERS		INCHES	
	MIN	MAX	MIN	MAX
A	8.55	8.75	0.337	0.344
B	3.80	4.00	0.150	0.157
C	1.35	1.75	0.054	0.068
D	0.35	0.49	0.014	0.019
F	0.40	1.25	0.016	0.049
G	1.27 BSC		0.050 BSC	
J	0.19	0.25	0.008	0.009
K	0.10	0.25	0.004	0.009
M	0°	7°	0°	7°
P	5.80	6.20	0.228	0.244
R	0.25	0.50	0.010	0.019

### SOLDERING FOOTPRINT



DIMENSIONS: MILLIMETERS

\*For additional information on our Pb-Free strategy and soldering details, please download the ON Semiconductor Soldering and Mounting Techniques Reference Manual, SOLDERRM/D.

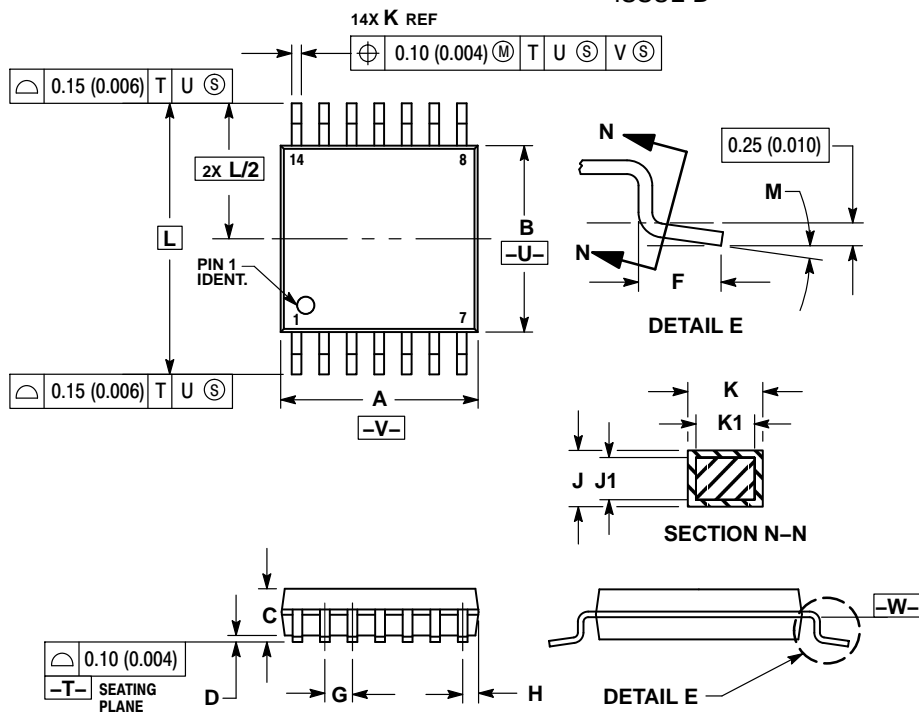
# MC33171, 2, 4, NCV33172, 4

## PACKAGE DIMENSIONS

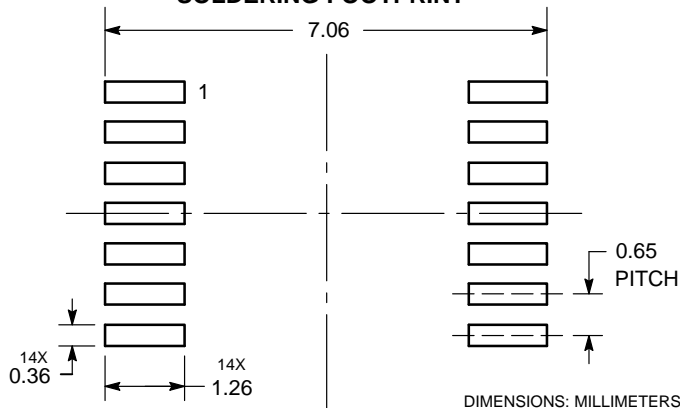
TSSOP-14  
CASE 948G  
ISSUE B

NOTES:

1. DIMENSIONING AND TOLERANCING PER ANSI Y14.5M, 1982.
2. CONTROLLING DIMENSION: MILLIMETER.
3. DIMENSION A DOES NOT INCLUDE MOLD FLASH, PROTRUSIONS OR GATE BURRS. MOLD FLASH OR GATE BURRS SHALL NOT EXCEED 0.15 (0.006) PER SIDE.
4. DIMENSION B DOES NOT INCLUDE INTERLEAD FLASH OR PROTRUSION. INTERLEAD FLASH OR PROTRUSION SHALL NOT EXCEED 0.25 (0.010) PER SIDE.
5. DIMENSION K DOES NOT INCLUDE DAMBAR PROTRUSION. ALLOWABLE DAMBAR PROTRUSION SHALL BE 0.08 (0.003) TOTAL IN EXCESS OF THE K DIMENSION AT MAXIMUM MATERIAL CONDITION.
6. TERMINAL NUMBERS ARE SHOWN FOR REFERENCE ONLY.
7. DIMENSION A AND B ARE TO BE DETERMINED AT DATUM PLANE -W--.



SOLDERING FOOTPRINT\*



\*For additional information on our Pb-Free strategy and soldering details, please download the ON Semiconductor Soldering and Mounting Techniques Reference Manual, SOLDERRM/D.

ON Semiconductor and the are registered trademarks of Semiconductor Components Industries, LLC (SCILLC) or its subsidiaries in the United States and/or other countries. SCILLC owns the rights to a number of patents, trademarks, copyrights, trade secrets, and other intellectual property. A listing of SCILLC's product/patent coverage may be accessed at [www.onsemi.com/site/pdf/Patent-Marking.pdf](http://www.onsemi.com/site/pdf/Patent-Marking.pdf). SCILLC reserves the right to make changes without further notice to any products herein. SCILLC makes no warranty, representation or guarantee regarding the suitability of its products for any particular purpose, nor does SCILLC assume any liability arising out of the application or use of any product or circuit, and specifically disclaims any and all liability, including without limitation special, consequential or incidental damages. "Typical" parameters which may be provided in SCILLC data sheets and/or specifications can and do vary in different applications and actual performance may vary over time. All operating parameters, including "Typicals" must be validated for each customer application by customer's technical experts. SCILLC does not convey any license under its patent rights nor the rights of others. SCILLC products are not designed, intended, or authorized for use as components in systems intended for surgical implant into the body, or other applications intended to support or sustain life, or for any other application in which the failure of the SCILLC product could create a situation where personal injury or death may occur. Should Buyer purchase or use SCILLC products for any such unintended or unauthorized application, Buyer shall indemnify and hold SCILLC and its officers, employees, subsidiaries, affiliates, and distributors harmless against all claims, costs, damages, and expenses, and reasonable attorney fees arising out of, directly or indirectly, any claim of personal injury or death associated with such unintended or unauthorized use, even if such claim alleges that SCILLC was negligent regarding the design or manufacture of the part. SCILLC is an Equal Opportunity/Affirmative Action Employer. This literature is subject to all applicable copyright laws and is not for resale in any manner.

### PUBLICATION ORDERING INFORMATION

LITERATURE FULFILLMENT:

Literature Distribution Center for ON Semiconductor  
P.O. Box 5163, Denver, Colorado 80217 USA  
Phone: 303-675-2175 or 800-344-3860 Toll Free USA/Canada  
Fax: 303-675-2176 or 800-344-3867 Toll Free USA/Canada  
Email: [orderlit@onsemi.com](mailto:orderlit@onsemi.com)

N. American Technical Support: 800-282-9855 Toll Free  
USA/Canada  
Europe, Middle East and Africa Technical Support:  
Phone: 421 33 790 2910  
Japan Customer Focus Center  
Phone: 81-3-5817-1050

ON Semiconductor Website: [www.onsemi.com](http://www.onsemi.com)

Order Literature: <http://www.onsemi.com/orderlit>

For additional information, please contact your local Sales Representative

## Looking for pricing, stock, or lifecycle information?

Click below to explore more details on WIN SOURCE:

 [View NCV33172DR2G on WIN SOURCE](#)

 [ON Semiconductor](#) Information

## Optimize Your Supply Chain with WIN SOURCE Solutions

-  Global Sourcing Solution
-  Obsolete Management
-  Cost Control Management
-  Shortage Management
-  Alternative Solution
-  Excess Inventory Management