



# THE DATASHEET OF SMF110AT1



# SMF5.0AT1 Series

## Zener Transient Voltage Suppressor SOD-123 Flat Lead Package

The SMF5.0A Series is designed to protect voltage sensitive components from high voltage, high energy transients. Excellent clamping capability, high surge capability, low zener impedance and fast response time. Because of its small size, it is ideal for use in cellular phones, portable devices, business machines, power supplies and many other industrial/consumer applications.

### Specification Features:

- Stand-off Voltage: 5 – 170 Volts
- Peak Power – 200 Watts @ 1 ms (SMF5.0A – SMF58A)  
– 175 Watts @ 1 ms (SMF60A – SMF170A)
- Maximum Clamp Voltage @ Peak Pulse Current
- Low Leakage
- Response Time is Typically < 1 ns
- ESD Rating of Class 3 (> 16 kV) per Human Body Model  
IEC61000-4-2 Level 4 ESD Protection  
IEC61000-4-4 40 A ESD Protection
- Low Profile – Maximum Height of 1.0 mm
- Small Footprint – Footprint Area of 8.45 mm<sup>2</sup>
- Supplied in 8 mm Tape and Reel – 3,000 Units per Reel
- Cathode Indicated by Polarity Band

### Mechanical Characteristics:

**CASE:** Void-free, transfer-molded, thermosetting plastic

Epoxy Meets UL94, VO

**LEAD FINISH:** 100% Matte Sn (Tin)

**MOUNTING POSITION:** Any

**QUALIFIED MAX REFLOW TEMPERATURE:** 260°C

Device Meets MSL 1 Requirements



ON Semiconductor®

<http://onsemi.com>

**PLASTIC SURFACE MOUNT  
ZENER OVERVOLTAGE  
TRANSIENT SUPPRESSOR  
5 – 170 VOLTS  
200 WATT PEAK POWER**

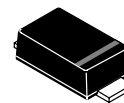
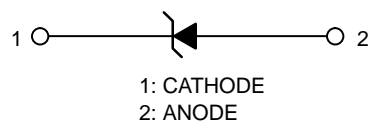

**SOD-123FL  
CASE 498  
PLASTIC**

### MARKING DIAGRAM

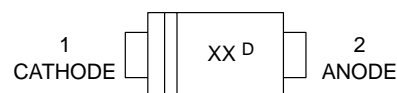

XX = Specific Device Code  
D = Date Code

### ORDERING INFORMATION

| Device    | Package   | Shipping          |
|-----------|-----------|-------------------|
| SMFxxxAT1 | SOD-123FL | 3,000/Tape & Reel |

**LEAD ORIENTATION IN TAPE:**  
Cathode Lead to Sprocket Holes

# SMF5.0AT1 Series

## MAXIMUM RATINGS

| Rating  | Symbol                | Value       | Unit                       |
|---|-----------------------|-------------|----------------------------|
| Maximum $P_{pk}$ Dissipation (PW=10/1000 $\mu$ s) (Note 1) SMF60A – SMF170A                 | $P_{pk}$              | 175         | W                          |
| Maximum $P_{pk}$ Dissipation (PW=10/1000 $\mu$ s) (Note 1) SMF5.0A – SMF58A                 | $P_{pk}$              | 200         | W                          |
| Maximum $P_{pk}$ Dissipation @ $T_A = 25^\circ\text{C}$ , (PW=8/20 $\mu$ s) (Note 2)        | $P_{pk}$              | 1000        | W                          |
| DC Power Dissipation @ $T_A = 25^\circ\text{C}$ (Note 3)<br>Derate above $25^\circ\text{C}$ | $P_D$                 | 385         | mW                         |
| Thermal Resistance from Junction to Ambient (Note 3)  | $R_{\theta JA}$       | 4.0         | $\text{mW}/^\circ\text{C}$ |
| Thermal Resistance from Junction to Lead (Note 3)   | $R_{\theta Jcathode}$ | 325         | $^\circ\text{C}/\text{W}$  |
| Operating and Storage Temperature Range   | $T_J, T_{stg}$        | -55 to +150 | $^\circ\text{C}$           |

1. Non-repetitive current pulse at  $T_A = 25^\circ\text{C}$ , per waveform of Figure 2.
2. Non-repetitive current pulse at  $T_A = 25^\circ\text{C}$ , per waveform of Figure 3.
3. Mounted with recommended minimum pad size, DC board FR-4.

**ELECTRICAL CHARACTERISTICS** ( $T_A = 25^\circ\text{C}$  unless otherwise noted,  $V_F = 3.5\text{ V Max.}$  @  $I_F$  (Note 4) = 12 A)

| Symbol    | Parameter                                   |
|-----------|---|
| $I_{PP}$  | Maximum Reverse Peak Pulse Current          |
| $V_C$     | Clamping Voltage @ $I_{PP}$                 |
| $V_{RWM}$ | Working Peak Reverse Voltage                |
| $I_R$     | Maximum Reverse Leakage Current @ $V_{RWM}$ |
| $V_{BR}$  | Breakdown Voltage @ $I_T$                   |
| $I_T$     | Test Current                                |
| $I_F$     | Forward Current                             |
| $V_F$     | Forward Voltage @ $I_F$                     |

4. 1/2 sine wave (or equivalent square wave), PW = 8.3 ms, duty cycle = 4 pulses per minute maximum.

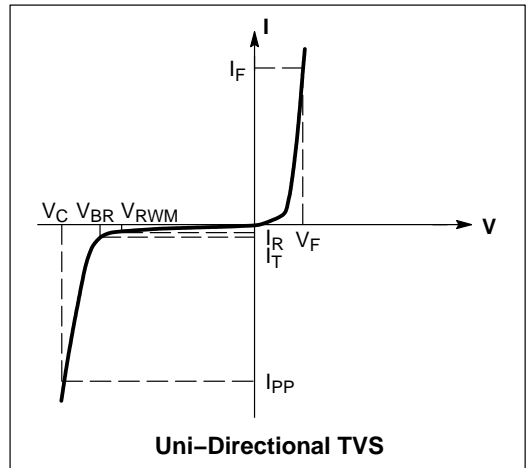

## SMF5.0AT1 Series

### ELECTRICAL CHARACTERISTICS ( $T_L = 30^\circ\text{C}$ unless otherwise noted, $V_F = 1.25$ Volts @ 200 mA)

| Device  | Marking | $V_{RWM}$ (V) | $V_{BR}$ @ $I_T$ (V) (Note 6) |       |      | $I_T$ | $I_R$ @ $V_{RWM}$ | $V_C(\text{Max})$ | $I_{PP}(\text{Max})$ (A) |
|---------|---------|---------------|-------------------------------|-------|------|-------|-------------------|-------------------|--------------------------|
|         |         | (Note 5)      | Min                           | Nom   | Max  | (mA)  | ( $\mu\text{A}$ ) | (V)               | (Note 7)                 |
| SMF5.0A | KE      | 5             | 6.4                           | 6.7   | 7    | 10    | 400               | 9.2               | 21.7                     |
| SMF6.0A | KG      | 6             | 6.67                          | 7.02  | 7.37 | 10    | 400               | 10.3              | 19.4                     |
| SMF6.5A | KK      | 6.5           | 7.22                          | 7.6   | 7.98 | 10    | 250               | 11.2              | 17.9                     |
| SMF7.0A | KM      | 7             | 7.78                          | 8.2   | 8.6  | 10    | 100               | 12                | 16.7                     |
| SMF7.5A | KP      | 7.5           | 8.33                          | 8.77  | 9.21 | 1     | 50                | 12.9              | 15.5                     |
| SMF8.0A | KR      | 8             | 8.89                          | 9.36  | 9.83 | 1     | 25                | 13.6              | 14.7                     |
| SMF8.5A | KT      | 8.5           | 9.44                          | 9.92  | 10.4 | 1     | 10                | 14.4              | 13.9                     |
| SMF9.0A | KV      | 9             | 10                            | 10.55 | 11.1 | 1     | 5                 | 15.4              | 13.0                     |
| SMF10A  | KX      | 10            | 11.1                          | 11.7  | 12.3 | 1     | 2.5               | 17                | 11.8                     |
| SMF11A  | KZ      | 11            | 12.2                          | 12.85 | 13.5 | 1     | 2.5               | 18.2              | 11.0                     |
| SMF12A  | LE      | 12            | 13.3                          | 14    | 14.7 | 1     | 2.5               | 19.9              | 10.1                     |
| SMF13A  | LG      | 13            | 14.4                          | 15.15 | 15.9 | 1     | 1                 | 21.5              | 9.3                      |
| SMF14A  | LK      | 14            | 15.6                          | 16.4  | 17.2 | 1     | 1                 | 23.2              | 8.6                      |
| SMF15A  | LM      | 15            | 16.7                          | 17.6  | 18.5 | 1     | 1                 | 24.4              | 8.2                      |
| SMF16A  | LP      | 16            | 17.8                          | 18.75 | 19.7 | 1     | 1                 | 26                | 7.7                      |
| SMF17A  | LR      | 17            | 18.9                          | 19.9  | 20.9 | 1     | 1                 | 27.6              | 7.2                      |
| SMF18A  | LT      | 18            | 20                            | 21    | 22.1 | 1     | 1                 | 29.2              | 6.8                      |
| SMF20A  | LV      | 20            | 22.2                          | 23.35 | 24.5 | 1     | 1                 | 32.4              | 6.2                      |
| SMF22A  | LX      | 22            | 24.4                          | 25.6  | 26.9 | 1     | 1                 | 35.5              | 5.6                      |
| SMF24A  | LZ      | 24            | 26.7                          | 28.1  | 29.5 | 1     | 1                 | 38.9              | 5.1                      |
| SMF26A  | ME      | 26            | 28.9                          | 30.4  | 31.9 | 1     | 1                 | 42.1              | 4.8                      |
| SMF28A  | MG      | 28            | 31.1                          | 32.8  | 34.4 | 1     | 1                 | 45.4              | 4.4                      |
| SMF30A  | MK      | 30            | 33.3                          | 35.1  | 36.8 | 1     | 1                 | 48.4              | 4.1                      |
| SMF33A  | MM      | 33            | 36.7                          | 38.7  | 40.6 | 1     | 1                 | 53.3              | 3.8                      |
| SMF36A  | MP      | 36            | 40                            | 42.1  | 44.2 | 1     | 1                 | 58.1              | 3.4                      |
| SMF40A  | MR      | 40            | 44.4                          | 46.8  | 49.1 | 1     | 1                 | 64.5              | 3.1                      |
| SMF43A  | MT      | 43            | 47.8                          | 50.3  | 52.8 | 1     | 1                 | 69.4              | 2.9                      |
| SMF45A  | MV      | 45            | 50                            | 52.65 | 55.3 | 1     | 1                 | 72.7              | 2.8                      |
| SMF48A  | MX      | 48            | 53.3                          | 56.1  | 58.9 | 1     | 1                 | 77.4              | 2.6                      |
| SMF51A  | MZ      | 51            | 56.7                          | 59.7  | 62.7 | 1     | 1                 | 82.4              | 2.4                      |
| SMF54A  | NE      | 54            | 60                            | 63.15 | 66.3 | 1     | 1                 | 87.1              | 2.3                      |
| SMF58A  | NG      | 58            | 64.4                          | 67.8  | 71.2 | 1     | 1                 | 93.6              | 2.1                      |
| SMF60A  | NK      | 60            | 66.7                          | 70.2  | 73.7 | 1     | 1                 | 96.8              | 1.8                      |
| SMF64A  | NM      | 64            | 71.1                          | 74.85 | 78.6 | 1     | 1                 | 103               | 1.7                      |
| SMF70A  | NP      | 70            | 77.8                          | 81.9  | 86   | 1     | 1                 | 113               | 1.5                      |
| SMF75A  | NR      | 75            | 83.3                          | 87.7  | 92.1 | 1     | 1                 | 121               | 1.4                      |
| SMF78A  | NT      | 78            | 86.7                          | 91.25 | 95.8 | 1     | 1                 | 126               | 1.4                      |
| SMF85A  | NV      | 85            | 94.4                          | 99.2  | 104  | 1     | 1                 | 137               | 1.3                      |
| SMF90A  | NX      | 90            | 100                           | 105.5 | 111  | 1     | 1                 | 146               | 1.2                      |
| SMF100A | NZ      | 100           | 111                           | 117   | 123  | 1     | 1                 | 162               | 1.1                      |
| SMF110A | PE      | 110           | 122                           | 128.5 | 135  | 1     | 1                 | 177               | 1.0                      |
| SMF120A | PG      | 120           | 133                           | 140   | 147  | 1     | 1                 | 193               | 0.9                      |
| SMF130A | PK      | 130           | 144                           | 151.5 | 159  | 1     | 1                 | 209               | 0.8                      |
| SMF150A | PM      | 150           | 167                           | 176   | 185  | 1     | 1                 | 243               | 0.7                      |
| SMF160A | PP      | 160           | 178                           | 187.5 | 197  | 1     | 1                 | 259               | 0.7                      |
| SMF170A | PR      | 170           | 189                           | 199   | 209  | 1     | 1                 | 275               | 0.6                      |

5. A transient suppressor is normally selected according to the Working Peak Reverse Voltage ( $V_{RWM}$ ) which should be equal to or greater than the DC or continuous peak operating voltage level.

6.  $V_{BR}$  measured at pulse test current  $I_T$  at ambient temperature of  $25^\circ\text{C}$ .

7. Surge current waveform per Figure 2 and derate per Figure 3.

# SMF5.0AT1 Series

## TYPICAL PROTECTION CIRCUIT

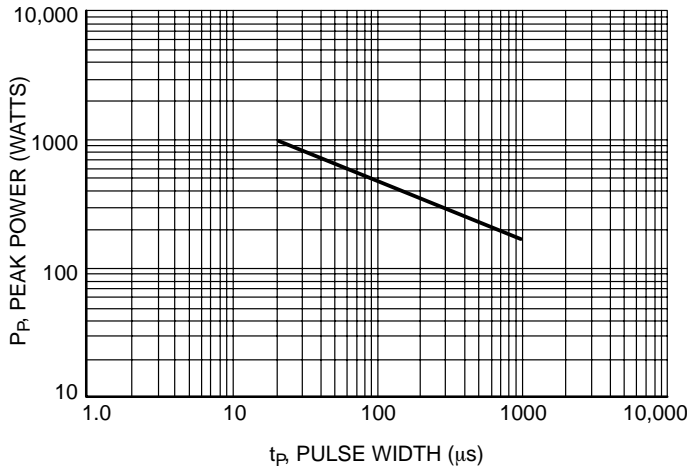
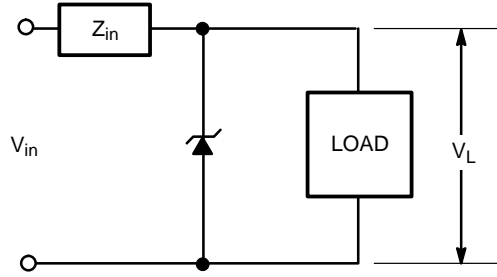

Figure 1. Pulse Rating Curve

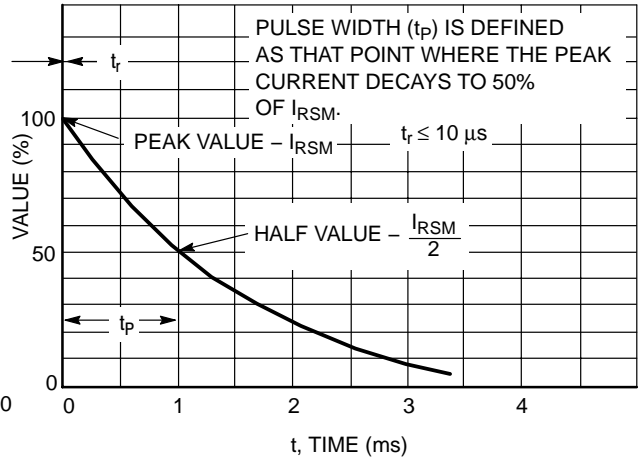

Figure 2. 10 X 1000  $\mu$ s Pulse Waveform

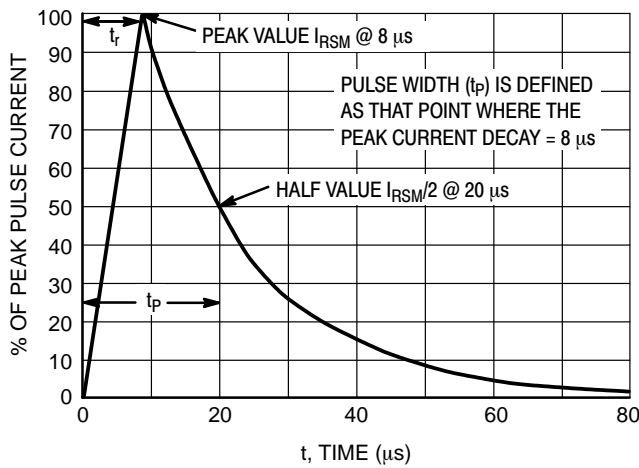

Figure 3. 8 X 20  $\mu$ s Pulse Waveform

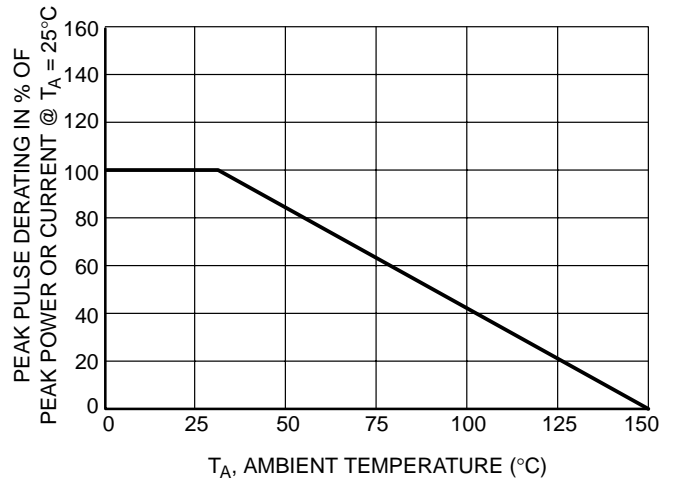

Figure 4. Pulse Derating Curve

# SMF5.0AT1 Series

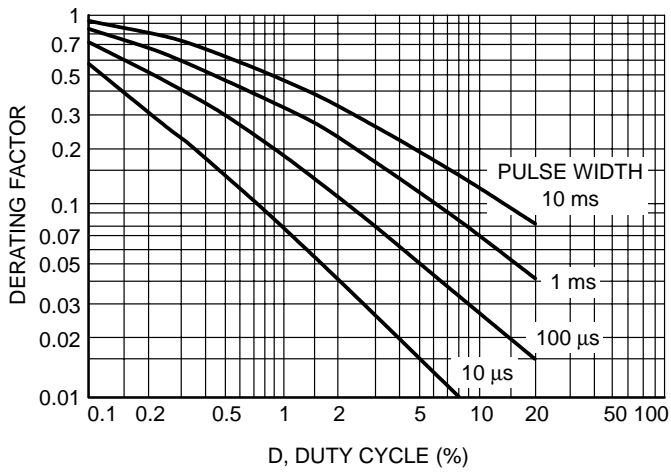

Figure 5. Typical Derating Factor for Duty Cycle

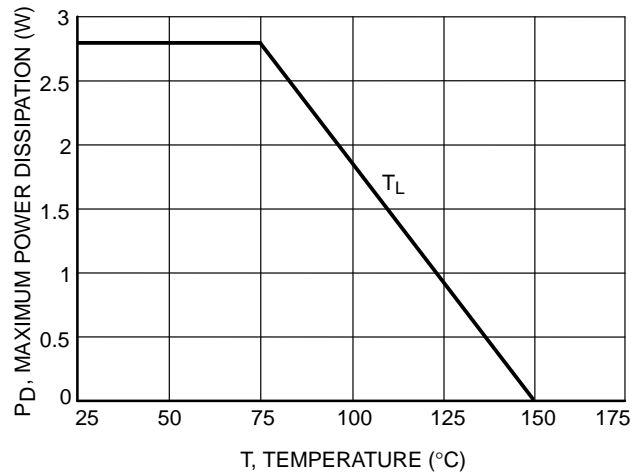

Figure 6. Steady State Power Derating

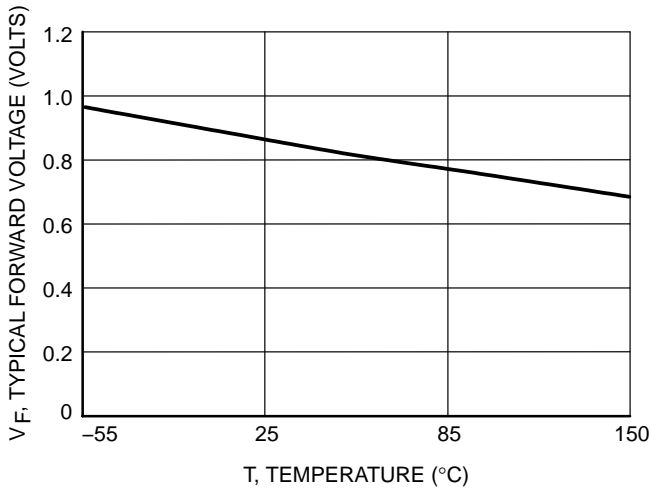

Figure 7. Forward Voltage

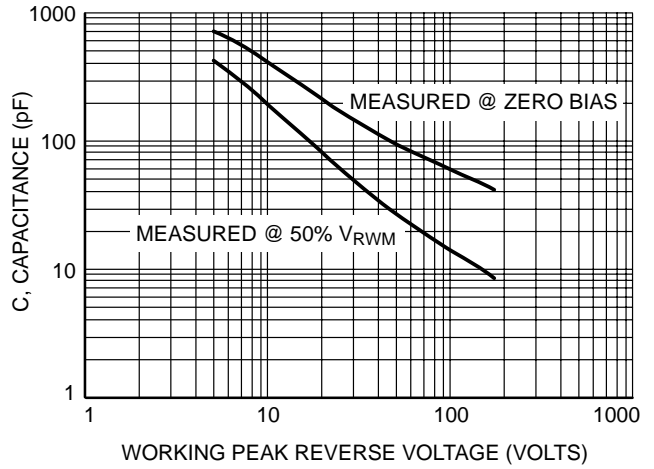

Figure 8. Capacitance versus Working Peak Reverse Voltage

INFORMATION FOR USING THE SOD-123 FLAT LEAD SURFACE MOUNT PACKAGE

MINIMUM RECOMMENDED FOOTPRINT FOR SURFACE MOUNTED APPLICATIONS

Surface mount board layout is a critical portion of the total design. The footprint for the semiconductor packages must be the correct size to insure proper solder connection

interface between the board and the package. With the correct pad geometry, the packages will self align when subjected to a solder reflow process.

RECOMMENDED FOOTPRINT FOR SOD-123FL

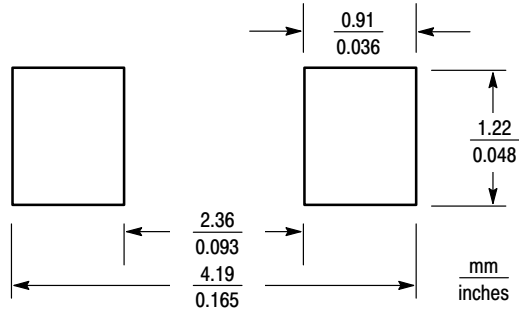

POWERMITE POWER DISSIPATION

The power dissipation of the SOD-123 Flat Lead is a function of the mounting pad size. This can vary from the minimum pad size for soldering to a pad size given for maximum power dissipation. Power dissipation for a surface mount device is determined by  $T_{J(max)}$ , the maximum rated junction temperature of the die,  $R_{\theta JA}$ , the thermal resistance from the device junction to ambient, and the operating temperature,  $T_A$ . Using the values provided on the data sheet for the SOD-123 Flat Lead package,  $P_D$  can be calculated as follows:

$$P_D = \frac{T_{J(max)} - T_A}{R_{\theta JA}}$$

The values for the equation are found in the maximum ratings table on the data sheet. Substituting these values into the equation for an ambient temperature  $T_A$  of 25°C,

one can calculate the power dissipation of the device which in this case is 385 milliwatts.

$$P_D = \frac{150^\circ\text{C} - 25^\circ\text{C}}{325^\circ\text{C/W}} = 385 \text{ milliwatts}$$

The 325°C/W for the SOD-123 Flat Lead package assumes the use of the recommended footprint on a glass epoxy printed circuit board to achieve a power dissipation of 385 milliwatts. There are other alternatives to achieving higher power dissipation from the SOD-123 Flat Lead package. Another alternative would be to use a ceramic substrate or an aluminum core board such as Thermal Clad®. Using a board material such as Thermal Clad, an aluminum core board, the power dissipation can be doubled using the same footprint.

SOLDERING PRECAUTIONS

The melting temperature of solder is higher than the rated temperature of the device. When the entire device is heated to a high temperature, failure to complete soldering within a short time could result in device failure. Therefore, the following items should always be observed in order to minimize the thermal stress to which the devices are subjected.

- Always preheat the device.
- The delta temperature between the preheat and soldering should be 100°C or less.\*
- When preheating and soldering, the temperature of the leads and the case must not exceed the maximum temperature ratings as shown on the data sheet. When using infrared heating with the reflow soldering method, the difference shall be a maximum of 10°C.

- The soldering temperature and time shall not exceed 260°C for more than 10 seconds.
- When shifting from preheating to soldering, the maximum temperature gradient shall be 5°C or less.
- After soldering has been completed, the device should be allowed to cool naturally for at least three minutes. Gradual cooling should be used as the use of forced cooling will increase the temperature gradient and result in latent failure due to mechanical stress.
- Mechanical stress or shock should not be applied during cooling.

\* Soldering a device without preheating can cause excessive thermal shock and stress which can result in damage to the device.

# SMF5.0AT1 Series

## OUTLINE DIMENSIONS

# Transient Voltage Suppressor – Surface Mounted

---

## 200 Watt Peak Power

SOD-123FL  
CASE 498-01  
ISSUE O

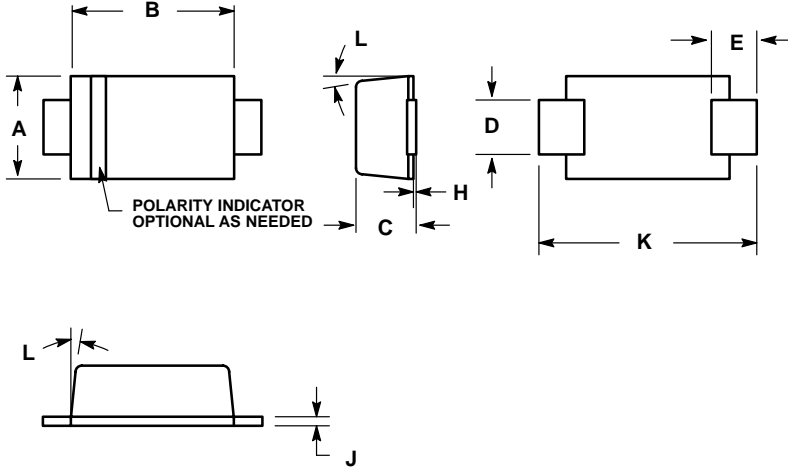

- NOTES:
1. DIMENSIONING AND TOLERANCING PER ANSI Y14.5M, 1982.
  2. CONTROLLING DIMENSION: MILLIMETER.
  3. DIMENSIONS A AND B DO NOT INCLUDE MOLD FLASH.
  4. DIMENSIONS D AND J ARE TO BE MEASURED ON FLAT SECTION OF THE LEAD: BETWEEN 0.10 AND 0.25 MM FROM THE LEAD TIP.

| DIM | MILLIMETERS |      | INCHES |       |
|-----|-------------|------|--------|-------|
|     | MIN         | MAX  | MIN    | MAX   |
| A   | 1.50        | 1.80 | 0.059  | 0.071 |
| B   | 2.50        | 2.90 | 0.098  | 0.114 |
| C   | 0.90        | 1.00 | 0.035  | 0.039 |
| D   | 0.70        | 1.10 | 0.028  | 0.043 |
| E   | 0.55        | 0.95 | 0.022  | 0.037 |
| H   | 0.00        | 0.10 | 0.000  | 0.004 |
| J   | 0.10        | 0.20 | 0.004  | 0.008 |
| K   | 3.40        | 3.80 | 0.134  | 0.150 |
| L   | 0°          | 8°   | 0°     | 8°    |

## SMF5.0AT1 Series

Thermal Clad is a registered trademark of the Bergquist Company.

**ON Semiconductor** and  are registered trademarks of Semiconductor Components Industries, LLC (SCILLC). SCILLC reserves the right to make changes without further notice to any products herein. SCILLC makes no warranty, representation or guarantee regarding the suitability of its products for any particular purpose, nor does SCILLC assume any liability arising out of the application or use of any product or circuit, and specifically disclaims any and all liability, including without limitation special, consequential or incidental damages. "Typical" parameters which may be provided in SCILLC data sheets and/or specifications can and do vary in different applications and actual performance may vary over time. All operating parameters, including "Typicals" must be validated for each customer application by customer's technical experts. SCILLC does not convey any license under its patent rights nor the rights of others. SCILLC products are not designed, intended, or authorized for use as components in systems intended for surgical implant into the body, or other applications intended to support or sustain life, or for any other application in which the failure of the SCILLC product could create a situation where personal injury or death may occur. Should Buyer purchase or use SCILLC products for any such unintended or unauthorized application, Buyer shall indemnify and hold SCILLC and its officers, employees, subsidiaries, affiliates, and distributors harmless against all claims, costs, damages, and expenses, and reasonable attorney fees arising out of, directly or indirectly, any claim of personal injury or death associated with such unintended or unauthorized use, even if such claim alleges that SCILLC was negligent regarding the design or manufacture of the part. SCILLC is an Equal Opportunity/Affirmative Action Employer.

### PUBLICATION ORDERING INFORMATION

**Literature Fulfillment:**

Literature Distribution Center for ON Semiconductor  
P.O. Box 5163, Denver, Colorado 80217 USA  
**Phone:** 303-675-2175 or 800-344-3860 Toll Free USA/Canada  
**Fax:** 303-675-2176 or 800-344-3867 Toll Free USA/Canada  
**Email:** ONlit@hibbertco.com

**N. American Technical Support:** 800-282-9855 Toll Free USA/Canada

**JAPAN:** ON Semiconductor, Japan Customer Focus Center  
2-9-1 Kamimeguro, Meguro-ku, Tokyo, Japan 153-0051  
**Phone:** 81-3-5773-3850

**ON Semiconductor Website:** <http://onsemi.com>

For additional information, please contact your local Sales Representative.

## Looking for pricing, stock, or lifecycle information?

Click below to explore more details on WIN SOURCE:

 [View SMF110AT1 on WIN SOURCE](#)

 [ON Semiconductor](#) Information

## Optimize Your Supply Chain with WIN SOURCE Solutions

-  Global Sourcing Solution
-  Obsolete Management
-  Cost Control Management
-  Shortage Management
-  Alternative Solution
-  Excess Inventory Management