

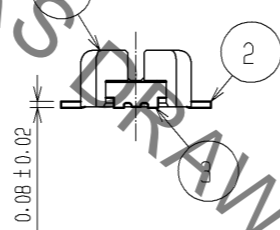

**THE DATASHEET OF
DF37B-24DP-0.4V(53)**

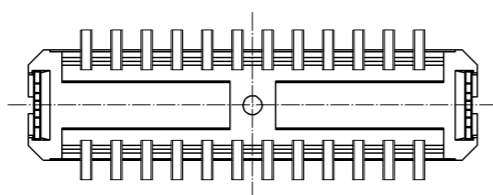

Sep.1.2019 Copyright 2019 HIROSE ELECTRIC CO., LTD. All Rights Reserved.
 In case of consideration for using Automotive equipment / device which demand high reliability, kindly contact our sales window correspondents.

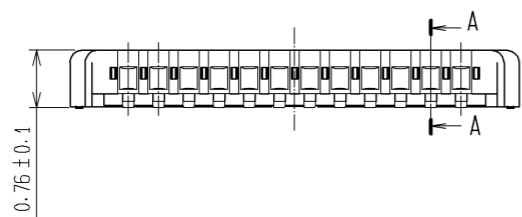
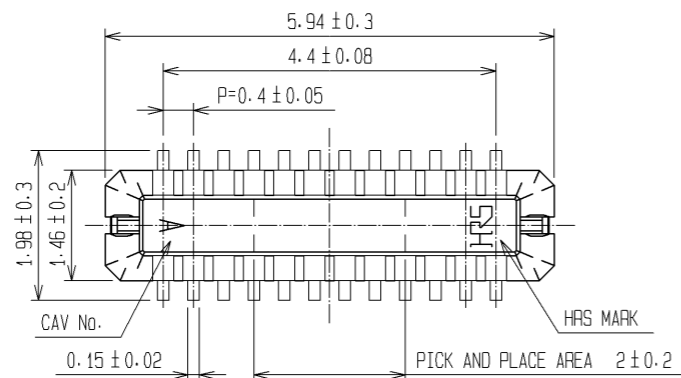

RECOMMENDED METAL MASK
OPENING PATTERN

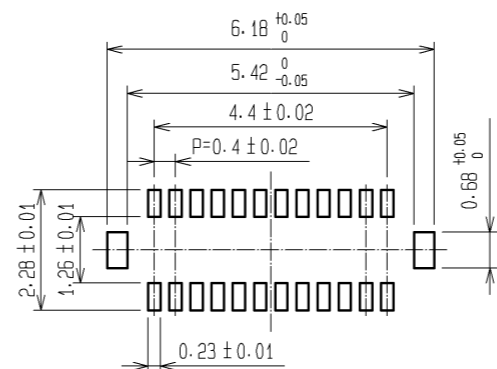

RECOMMENDED SOLDER PASTE THICKNESS: 120μm

RECOMMENDED PATTERN

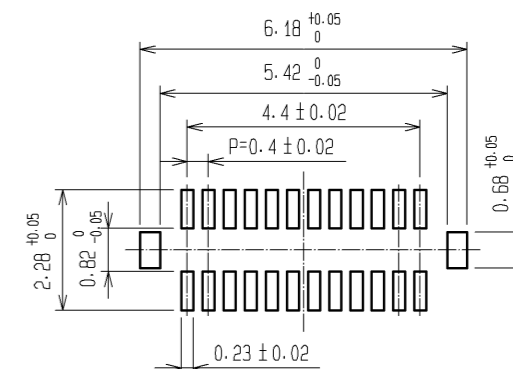

ENGAGEMENT FIGURE

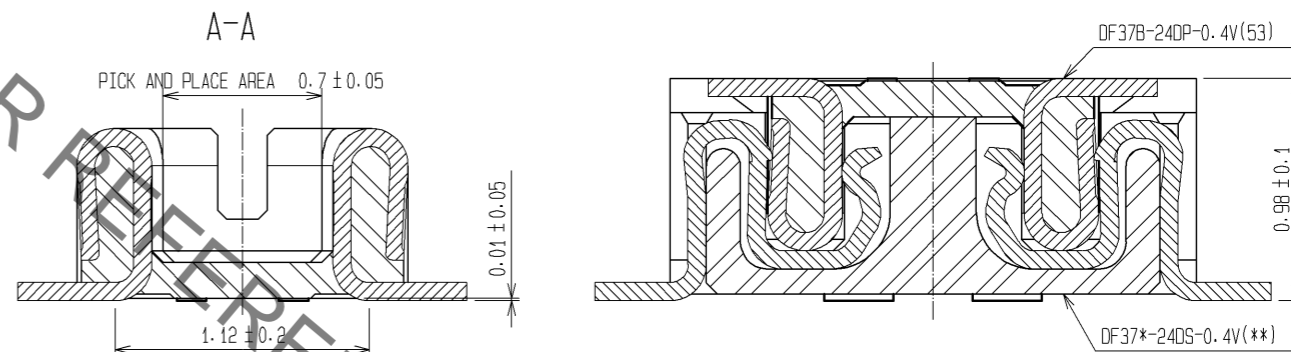

- NOTE 1. ALL LEADS CO-PLANARITY SHALL BE 0.1 MAX.
 2. PER REEL : 1000 CONNECTORS.
 3. AT THE BEGINNING OF THE REEL, 100 mm AT MIN SHALL BE EMPTY POCKETS.
 AT THE END OF THE REEL, 160 mm AT MIN SHALL BE EMPTY.
 4. CONTACT PLATING SPECIFICATIONS.
 CONTACT AREA : GOLD 0.05μm MIN.
 SMT LEAD : GOLD 0.05μm MIN.
 UNDERPLATING : NICKEL 1μm MIN.
 (SURFACE : SEALING)
 5. METAL HOLD DOWN PLATING SPECIFICATIONS.
 MOUNTING AREA: GOLD 0.05μm MIN.
 UNDERPLATING : NICKEL 1μm MIN.
 6. PEEL FORCE OF COVER TAPE REFERS TO JIS C 0806.

3	PHOSPHOR BRONZE	5	6	PS	PLASTIC REEL (BLACK)			
2	PHOSPHOR BRONZE	4	5	POLYESTER	CLEAR(COVER TAPE)			
1	LCP	UL94V-0, BLACK	4	PS	CLEAR(EMBOSSED CARRIER TAPE)			
NO.	MATERIAL	FINISH, REMARKS	NO.	MATERIAL	FINISH, REMARKS			
UNITS	mm	SCALE	FREE	COUNT	DESCRIPTION OF REVISIONS	DESIGNED	CHECKED	DATE
APPROVED : KH. IKEDA		09.01.07	DRAWING NO.		EDC3-308584-04			
CHECKED : TS. MIYAZAKI		09.01.07	PART NO.		DF37B-24DP-0.4V(53)			
DESIGNED : RT. SHIMIZU		09.01.07	CODE NO.		CL684-3009-4-53			
DRAWN : AK. AOYAGI		09.01.07						

Sep.1.2019 Copyright 2019 HIROSE ELECTRIC CO., LTD. All Rights Reserved.
 In case of consideration for using Automotive equipment / device which demand high reliability, kindly contact our sales window correspondents.

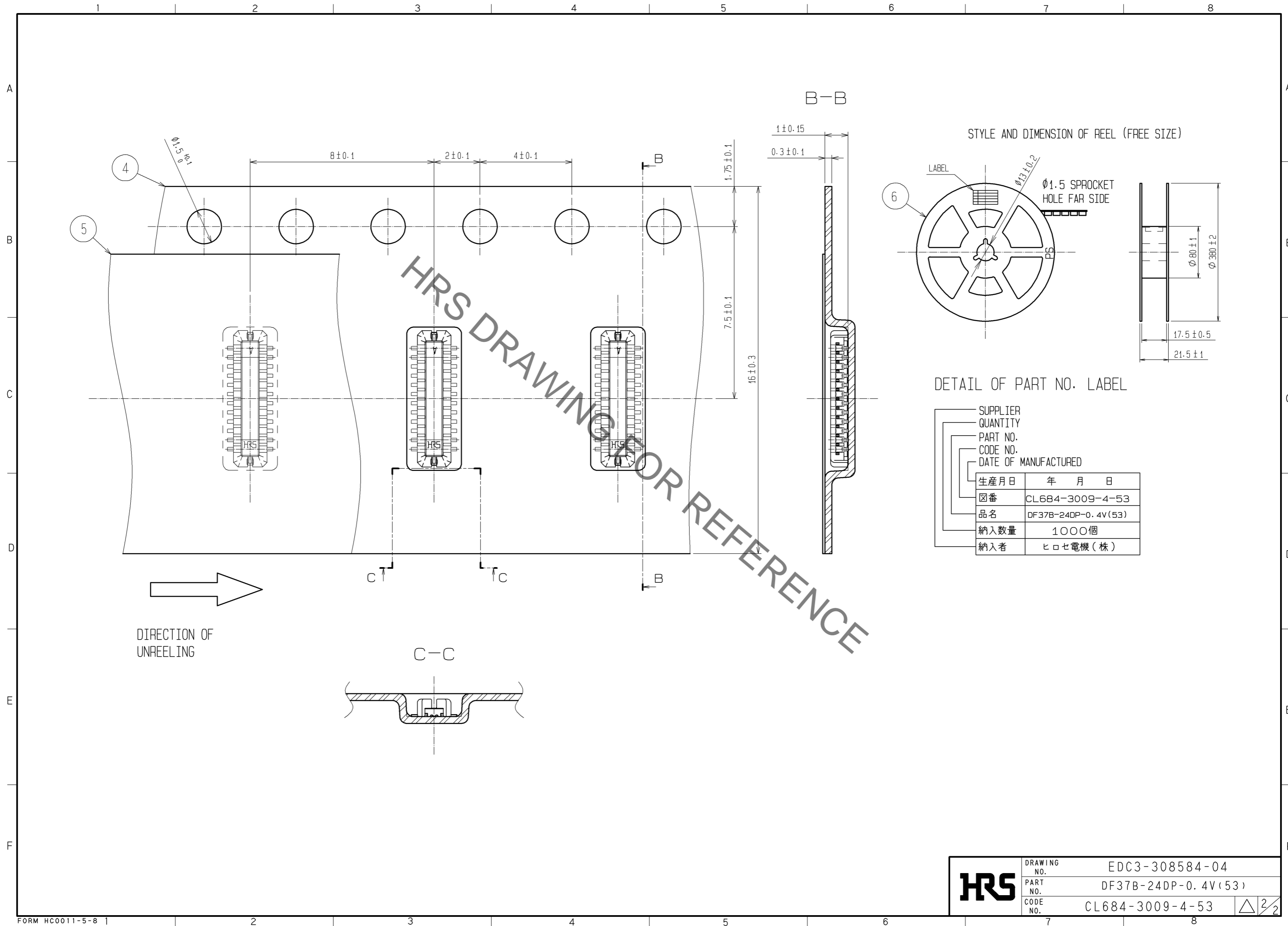

STYLE AND DIMENSION OF REEL (FREE SIZE)

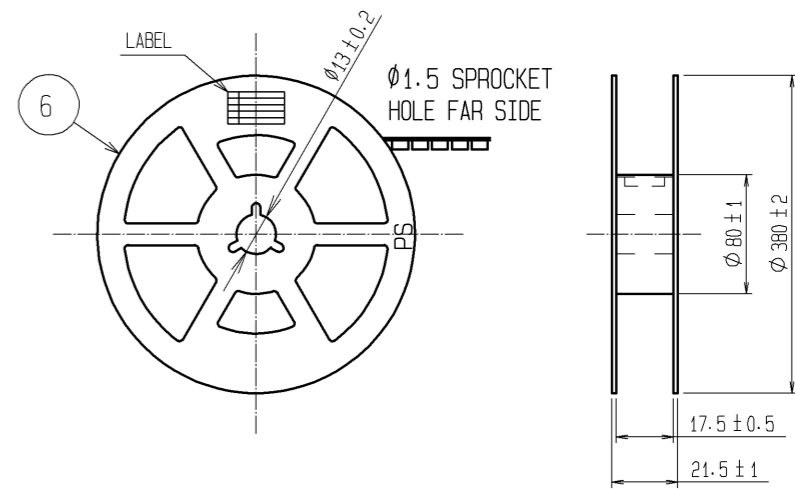

DETAIL OF PART NO. LABEL

SUPPLIER	
QUANTITY	
PART NO.	
CODE NO.	
DATE OF MANUFACTURED	
生産月日	年 月 日
図番	CL684-3009-4-53
品名	DF37B-24DP-0.4V(53)
納入数量	1000個
納入者	ヒロセ電機(株)

HRS	DRAWING NO.	EDC3-308584-04
	PART NO.	DF37B-24DP-0.4V(53)
	CODE NO.	CL684-3009-4-53
		\triangle 2/2

Looking for pricing, stock, or lifecycle information?

Click below to explore more details on WIN SOURCE:

- ⊖ [View DF37B-24DP-0.4V\(53\) on WIN SOURCE](#)
- ⊖ [Hirose Electric Co Ltd Information](#)

Optimize Your Supply Chain with WIN SOURCE Solutions

- ✓ Global Sourcing Solution
- ✓ Obsolete Management
- ✓ Cost Control Management
- ✓ Shortage Management
- ✓ Alternative Solution
- ✓ Excess Inventory Management