



**THE DATASHEET OF
AP1684MTR-G1**



AC/DC, HIGH PF, HIGH EFFICIENCY LED DRIVER CONTROLLER

Description

The AP1684 is a high performance AC/DC power factor corrected LED driver controller which is driving high voltage bipolar transistor. The device uses Pulse Frequency Modulation (PFM) technology to regulate output current while achieving high power factor and low THD. It operates as a boundary condition mode (BCM) buck controller which is good for EMI.

The AP1684 provides accurate constant current (CC) regulation while removing the opto-coupler and secondary control circuitry. It also eliminates the need of loop compensation circuitry while maintaining stability. It can meet the requirement of IEC6100-3-2 harmonic standard.

The AP1684 features low start-up current, low operation current and high voltage driving bipolar transistor. It adopts dynamic base driver control technology and valley on switching mode to achieve high efficiency. It also has rich protection features including over voltage, short circuit, over temperature protection.

The AP1684 is available in SO-8 package.

Applications

- LED Bulb Lamp
- LED Down Light
- GU10/E27
- Other Non-dimmable LED Lighting

Pin Assignments

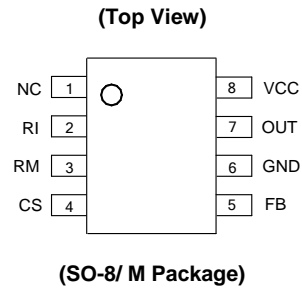

Features

- Low Start-up Current
- High PF and Low THD (PF > 0.9, THD < 30%)
- High Efficiency up to 92%
- BCM Mode
- Output Current Accuracy on IC Level: ±2%
- Tight LED Open Voltage
- Valley-mode Switching to Minimize the Transition Loss
- BJT Transistor Driver
- Dynamic Base Driver Control
- Open-load and Reload Detection
- Internal Protections:
 - Under Voltage Lock Out (UVLO)
 - Leading-edge Blanking (LEB)
 - Output Short Protection
 - Output Open Protection
 - Over Temperature Protection
- Low System Cost
- SO-8 Package
- **Totally Lead-Free & Fully RoHS Compliant (Notes 1 & 2)**
- **Halogen and Antimony Free. "Green" Device (Note 3)**

Notes: 1. No purposely added lead. Fully EU Directive 2002/95/EC (RoHS) & 2011/65/EU (RoHS 2) compliant.
 2. See http://www.diodes.com/quality/lead_free.html for more information about Diodes Incorporated's definitions of Halogen- and Antimony-free, "Green" and Lead-free.
 3. Halogen- and Antimony-free "Green" products are defined as those which contain <900ppm bromine, <900ppm chlorine (<1500ppm total Br + Cl) and <1000ppm antimony compounds.

Typical Applications Circuit

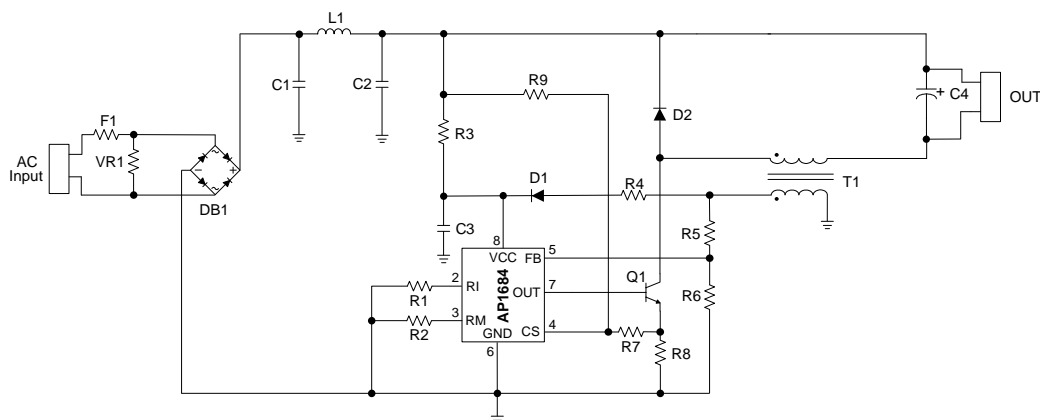

Pin Descriptions

Pin Number	Pin Name	Function
1	NC	No connection
2	RI	The initial Tonp tuning resistor
3	RM	Set the operating mode
4	CS	Primary current sensing
5	FB	The feedback voltage sensing from the auxiliary winding
6	GND	Ground
7	OUT	Gate driver output
8	VCC	Supply voltage of gate driver and control circuits of the IC

Functional Block Diagram

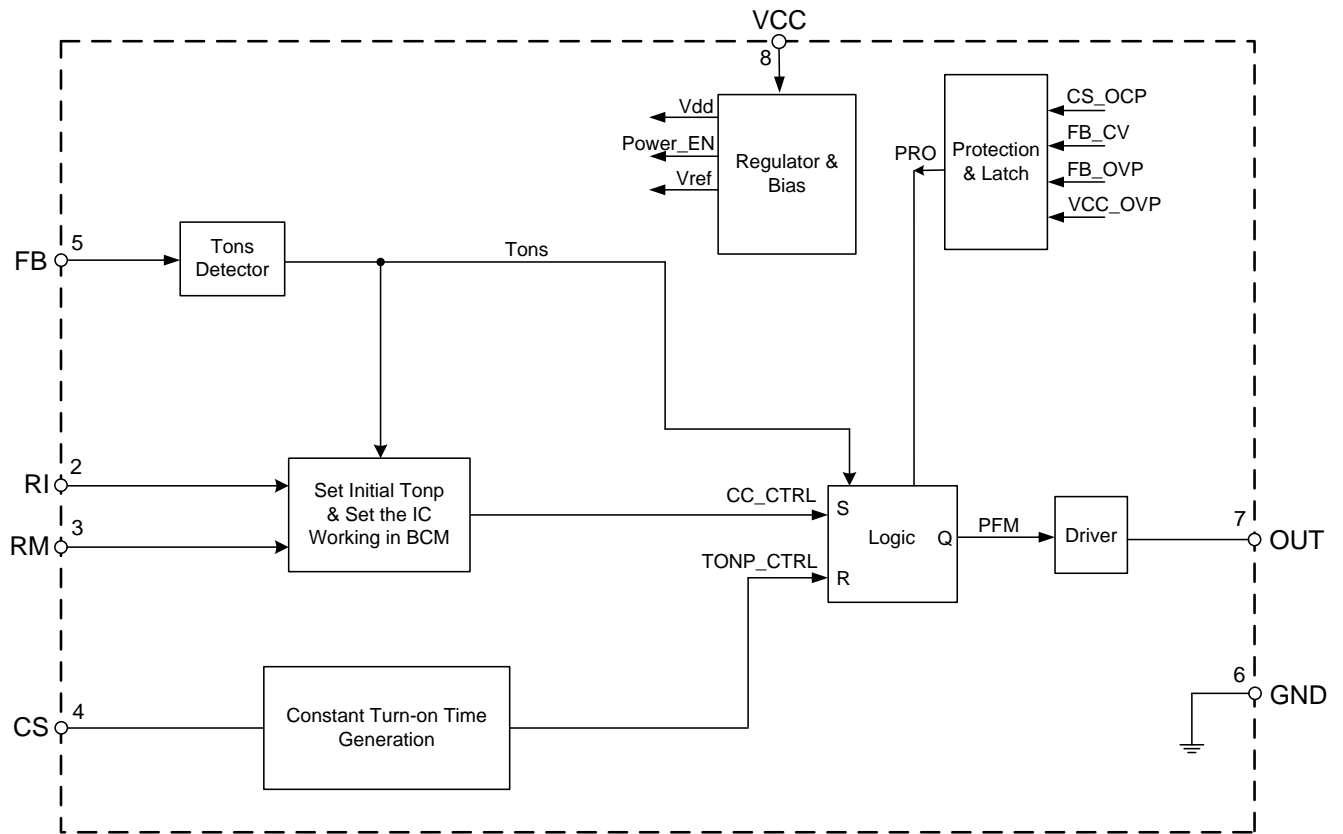

Absolute Maximum Ratings (@T_A = +25°C, unless otherwise specified. Note 4)

Symbol	Parameter	Rating	Unit
V _{CC}	Power Supply Voltage	-0.3 to 35	V
I _{OUT}	Driver Output Current	150	mA
V _{CS}	Voltage at CS to GND	-0.3 to +7	V
V _{FB}	FB Input Voltage	-40 to +10	V
T _J	Operating Junction Temperature	-40 to +150	°C
T _{STG}	Storage Temperature	-65 to +150	°C
T _{LEAD}	Lead Temperature (Soldering, 10 sec)	+300	°C
P _D	Power Dissipation (T _A = +50°C)	0.65	W
θ _{JA}	Thermal Resistance (Junction to Ambient)	160	°C/W
–	ESD (Human Body Model)	2000	V
–	ESD (Charged-device Model)	±1000	V

Note 4: Stresses greater than those listed under “Absolute Maximum Ratings” may cause permanent damage to the device. These are stress ratings only, and functional operation of the device at these or any other conditions beyond those indicated under “Recommended Operating Conditions” is not implied. Exposure to “Absolute Maximum Ratings” for extended periods may affect device reliability.

Recommended Operating Conditions

Symbol	Parameter	Min	Max	Unit
V _{CC}	Power Supply Voltage	7	25	V
T _A	Ambient Temperature	-40	+105	°C

Electrical Characteristics (@T_A = +25°C, unless otherwise specified.)

Symbol	Parameter	Conditions	Min	Typ	Max	Unit
UVLO Section						
V _{TH} (ST)	Start-up Threshold	–	18	19	20	V
V _{OPR} (Min)	Minimum Operating Voltage	After turn on	5.5	6.5	7.5	V
V _{CC_OVP}	VCC OVP Voltage	–	30	32	34	V
–	VCC Delatch Voltage (Note 5)	–	3	4	5	V
Standby Current Section						
I _{ST}	Start-up Current	V _{CC} = V _{TH} (ST) - 0.5V, Before start up	–	–	20	μA
I _{CC} (OPR)	Operating Current	Static	–	900	1300	μA
Drive Output Section						
I _{OUT}	Output Current (Note 5)	V _{CS_PEAK} = 1V	–	–	60	mA
V _{OS}	UVLO Saturation Voltage	V _{CC} = 0 to V _{CC-ON} , I _{SINK} = 10mA	–	–	1.1	V
Current Sense Section						
V _{CS_REF}	Current Sense Reference	–	–	1	–	V
V _{CS_CLAMP}	Current Sense Reference Clamp	–	1.2	1.4	–	V
t _{ONP_MIN}	Minimum t _{ONP}	–	700	–	1000	ns
t _{D(H-L)}	Delay to Output (Note 5)	–	50	150	250	ns
Feedback Input Section						
I _{FB}	Feedback Pin Input Leakage Current	V _{FB} = 2V	–	–	4	μA
V _{FB_CV}	FB CV Threshold	–	3.8	4	4.2	V
V _{FB_OVP}	FB OVP Threshold	–	4.5	6	7.5	V
Output Current						
–	System Output Current on Final Test Board	–	–	–	±2	%
Over Temperature Protection Section						
–	Shutdown Temperature (Note 5)	–	+150	–	–	°C
–	Temperature Hysteresis (Note 5)	–	–	+20	–	°C

Note 5: These parameters, although guaranteed by design, are not 100% tested in production.

Performance Characteristics

Supply Current vs. Supply Voltage

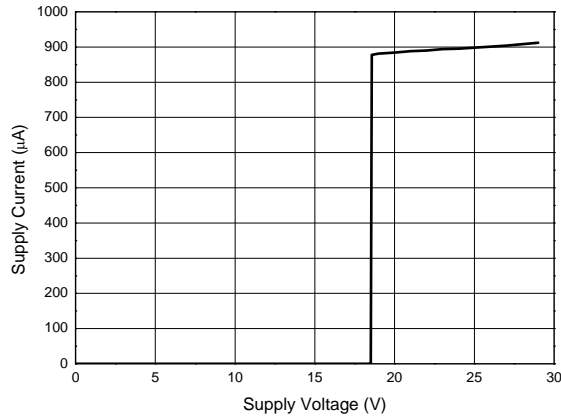

CV Threshold vs. Supply Voltage

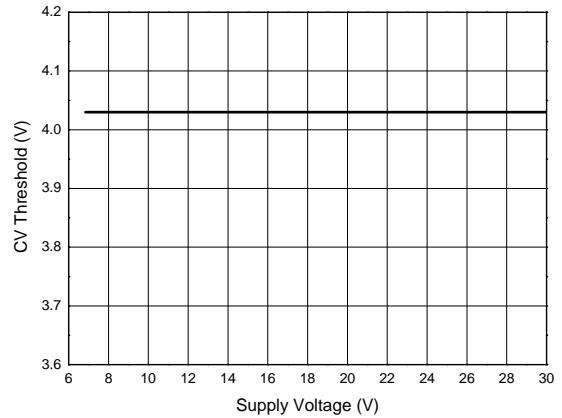

Start-up Voltage vs. Ambient Temperature

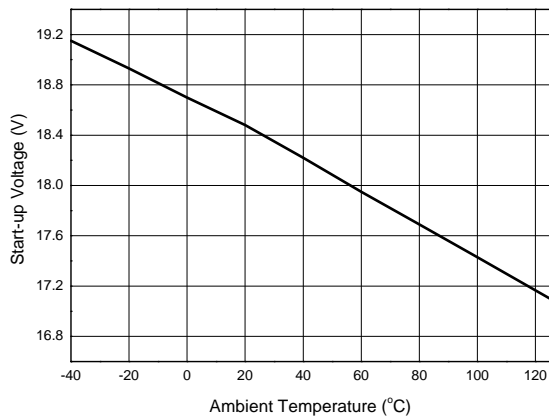

Minimal Operating Voltage vs. Ambient Temperature

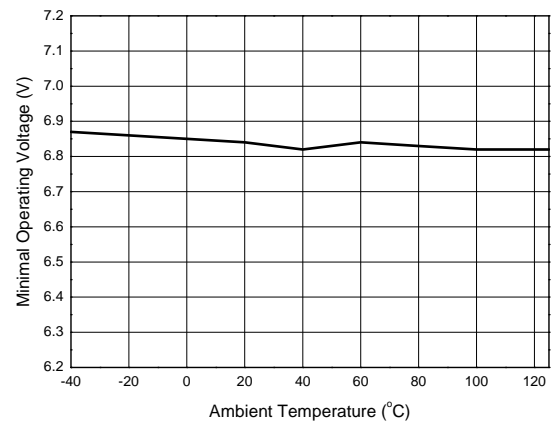

Start-up Current vs. Ambient Temperature

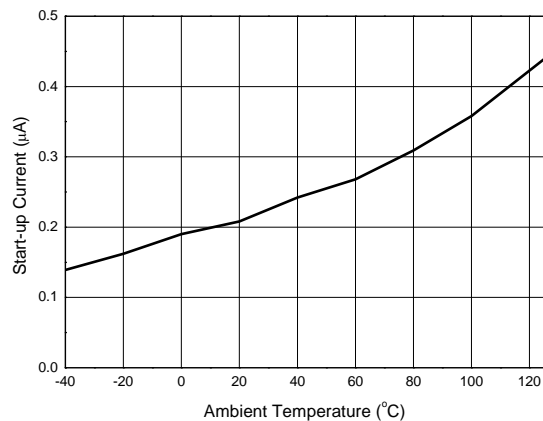

Operating Current vs. Ambient Temperature

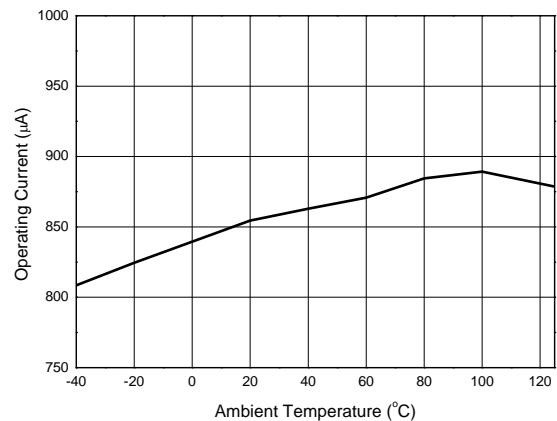

Performance Characteristics (Cont.)

CV Threshold vs. Ambient Temperature

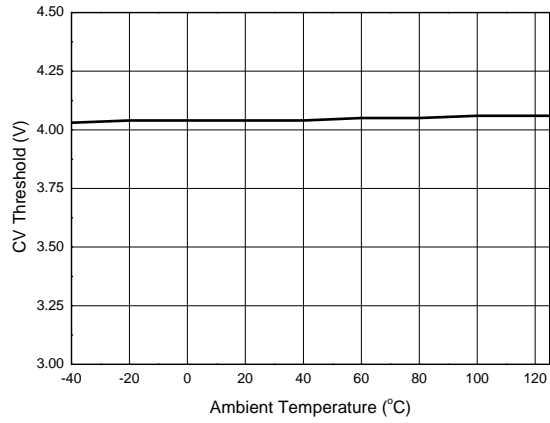

FB Leakage Current vs. Ambient Temperature

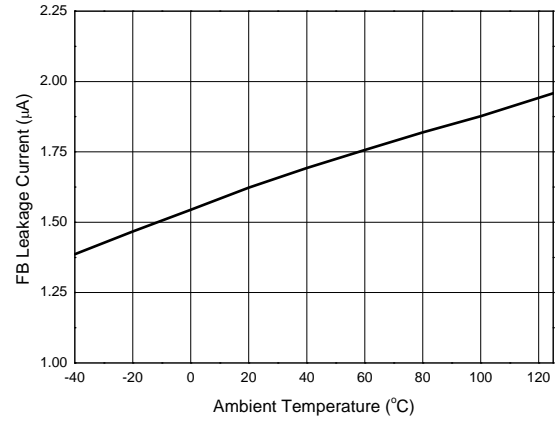

Application Information

The AP1684 is designed for single voltage application, and it features high power factor correction (PFC), low total harmonic distortion (THD), low BOM cost and good EMI performance. The device can be widely used in non-dimmable LED application such as GU10, bulb lamps, down lamp, etc. The AP1684 adopts constant on time control method within one AC cycle to achieve the high power factor and low THD. The control scheme is very simple, the power factor correction effectiveness is obvious, and the constant current control is also good enough.

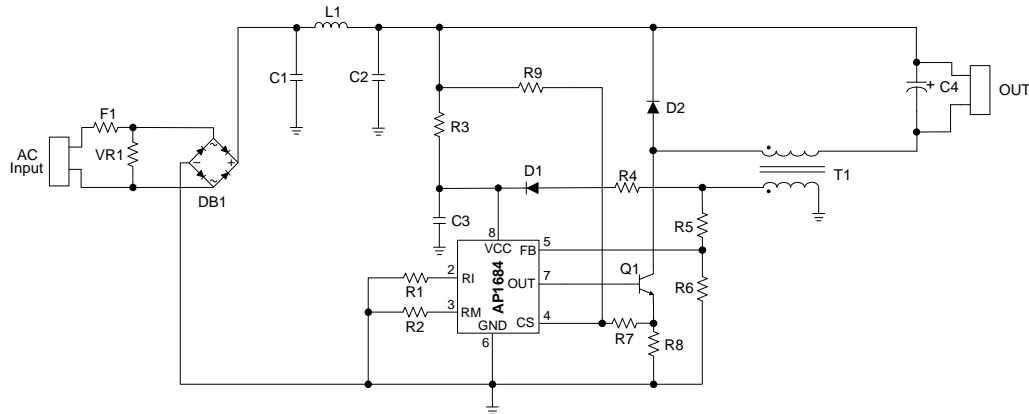

Figure 1. Typical Application Circuit

Design Parameters

Setting the Current Sense Resistor R8

As the AP1684 adopts constant on time control method, the current of the inductance will follow the input voltage to get a sinusoidal wave. The current sense pin CS of the AP1684 will sense the peak current of the inductance by sensing the voltage dropped on the current sense resistor R8, and the constant current control is realized by controlling the peak current. In buck structure, when the V_o is higher than V_{in} , no energy will be transferred from input to output which is called dead zone, and considering the dead zone of buck structure, the output current can be calculated as below:

$$I_{o_mean} = k \cdot \frac{1}{\pi} \cdot \frac{V_{cs_ref}}{R8}$$

Where,

V_{cs_ref} is the reference of the current sense, and the typical value is 1V.

K is the current modification coefficient, and the value of k is approximate to be 0.7.

So, the current sense resistor R8 is determined:

$$R8 = k \cdot \frac{V_{cs_ref}}{\pi \cdot I_{o_mean}}$$

Transformer Selection (T1)

The non-isolated buck circuit in Figure 1 is usually selected, and the system is operating at boundary conduction mode. The system's operating frequency does not keep constant, and considering the limit of the BJT's operating frequency, the minimum switching frequency at the crest is set as f_{min} , and then the buck inductance value L can be got:

$$L = \frac{(\sqrt{2} \cdot V_{in_rms} - V_o) \cdot R8 \cdot V_o}{V_{cs_ref} \cdot \sqrt{2} \cdot V_{in_rms} \cdot f_{min}}$$

Where,

V_o is the output voltage.

V_{in_rms} is the RMS value of the input voltage.

Application Information (Cont.)

The next step is determining the transformer's winding turns number, the worst case operation condition of transformer is at the peak voltage area of sine waveform input voltage where the current of across the inductance is the maximum value. The transformer design should be based on the worst case operation condition to guarantee that the transformer is not saturated. According to Ferrari's law of electromagnetic induction, the winding turns number of the buck inductance N_L is:

$$N_L = \frac{L \cdot I_{pk}}{A_e \cdot B_m} = \frac{L \cdot V_{cs_ref}}{A_e \cdot B_m \cdot R8}$$

Where,

A_e is the core effective area.

B_m is the maximum magnetic flux density.

The auxiliary winding is power supply for V_{CC} , the winding turns number N_{aux} is:

$$N_{aux} = N_L \cdot \frac{V_{cc}}{V_o + V_d}$$

Where,

V_{CC} is the power supply voltage for IC from auxiliary winding.

V_d is the voltage drop of the freewheel diode.

Setting the Initial On Time

As the AP1684 adopts constant on-time control method, the AP1684 will generate an initial on time to start a working cycle. If the initial on time is longer than the rated on time, overshoot will happen which could damage the LED. And a good system performance does not permit overshoot, so the appropriate initial on time should be guaranteed. And initial on time is determined by resistor R1 shown in Figure 1.

According to initial on time generation mechanism, the $t_{on_initial}$ is

$$t_{on_initial} = 80 \cdot R1 \cdot 10^{-12} s$$

To guarantee the system with no overshoot phenomenon, the resistor is selected

$$R1 = \frac{1.25 \cdot L}{R8 \cdot \sqrt{2} U_{in_rms_max}} \cdot 10^{10} \Omega$$

The system operation mode is determined by R2, to guarantee the system working at BCM mode, resistance R2 is generally selected as $R2 \leq R1$.

Valley on Control Method

The valley on function can provide low turn-on switching losses for buck converter. The voltage across the collector and emitter of the BJT is reflected by the auxiliary winding of the buck transformer. The voltage is sensed by the FB pin.

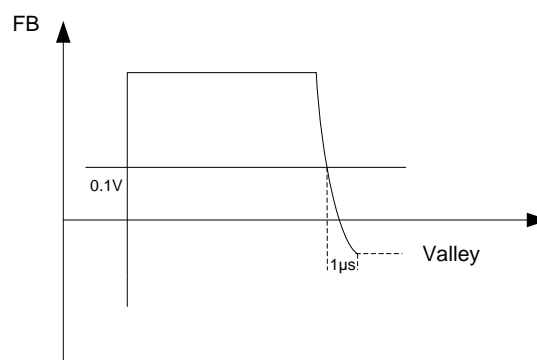

Figure 2. Valley on Control

Application Information (Cont.)

According to Figure 2, when the falling edge of 0.1V is sensed by the FB pin, the AP1684 will see the t_{OFF} time is over and delay $1\mu s$ to start a new operating cycle. In this way we can realize valley on function.

Fault Protection Over Voltage Protection and Output Open Protection

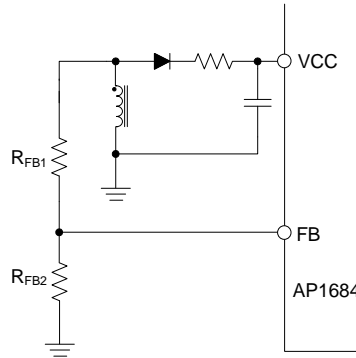

Figure 3. OVP Circuit

The output voltage is sensed by the auxiliary winding voltage of the buck transformer, the VCC pin and FB pin provide over voltage protection function. When the output is open or large transient happens, the output voltage will exceed the rated value. When the voltage of VCC cap exceeds V_{CC_ovp} or V_{FB_CV} , the over voltage is triggered and the IC will discharge VCC. When the VCC is below the UVLO threshold voltage, the IC will start a new work cycle and the VCC cap is charged again by start resistance. If the over voltage condition still exists, the system will work in hiccup mode.

Output Short Protection

When the output is shorted, the output voltage will be clamped at 0. At this condition, VCC will drop down without auxiliary winding for power supply. And the VCC will drop to UVLO threshold voltage, the IC will shut down and restart a new operating cycle, and the VCC is charged by startup resistance. When the VCC is higher than V_{CC_start} voltage, the IC will output a bunch of pulse to control BJT on and off, which will consume the energy stored in the VCC cap, because of no VCC supply from the auxiliary winding, the VCC will drop down to VCC UVLO threshold voltage again. If output short condition still exists, the system will operate in hiccup mode.

Over Temperature Protection

The AP1684 has two kinds of over temperature protection processes. First, the system is operating normally, the ambient temperature is changed to $+170^{\circ}C$ suddenly, the IC will trigger over temperature protection which leads to a latch work mode. Second, if the system starts, the over temperature protection will be triggered when the ambient temperature is higher than $+150^{\circ}C$. So the AP1684 can startup successfully when the ambient temperature is less than $+150^{\circ}C$.

Recommended Applications

The AP1684 is designed to drive BJT as the power switch, because of the BJT's current limit, the maximum output current is limited. In buck structure, the output voltage has some limitation because of the dead zone. The device is designed for single voltage application, so the recommended application is given in the table below.

AC Power Input	Output Voltage Range	Max Output Current
Low Mains Input	20V to 70V	200mA (13005)
High Mains Input	20V to 120V	200mA (13005)

Components Selection Guide

If the system's output spec is changed, please refer to the design sheet of the AP1684 and select the compatible system parameter. When the system needs to be adjusted slightly, please refer to the table below and adjust the value of the related component.

Item	Description	Related Components
I_o	LED current	R8
Output Current Ripple	Small current ripple is good for LED life	C4
$t_{on_initial}$	System initial on time, used to start up the system	R1
Output Open Voltage	Setting the output voltage when the LED is open	R5, R6
Line Compensation	To get a good line regulation	R7, R9
Startup Time	System startup time	R3, C3, T1
EMI	Pass EN 55022 class B with 6DB margin	L1, C1, C2

Ordering Information

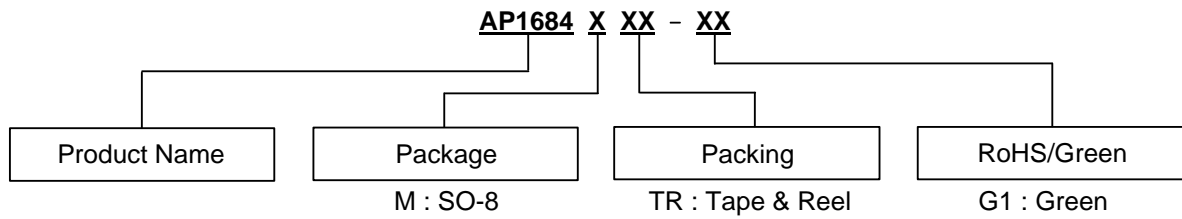

Diodes IC's Pb-free products with "G1" suffix in the part number, are RoHS compliant and green.

Package	Temperature Range	Part Number	Marking ID	Packing
SO-8	-40°C to +105°C	AP1684MTR-G1	1684M-G1	4000/13" Tape & Reel

Marking Information

(Top View)

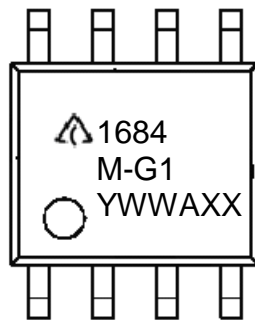

First and Second Lines: Logo and Marking ID
 Third Line: Date Code
 Y: Year
 WW: Work Week of Molding
 A: Assembly House Code
 XX: 7th and 8th Digits of Batch No.

Package Outline Dimensions (All dimensions in mm(inch).)

(1) Package Type: SO-8

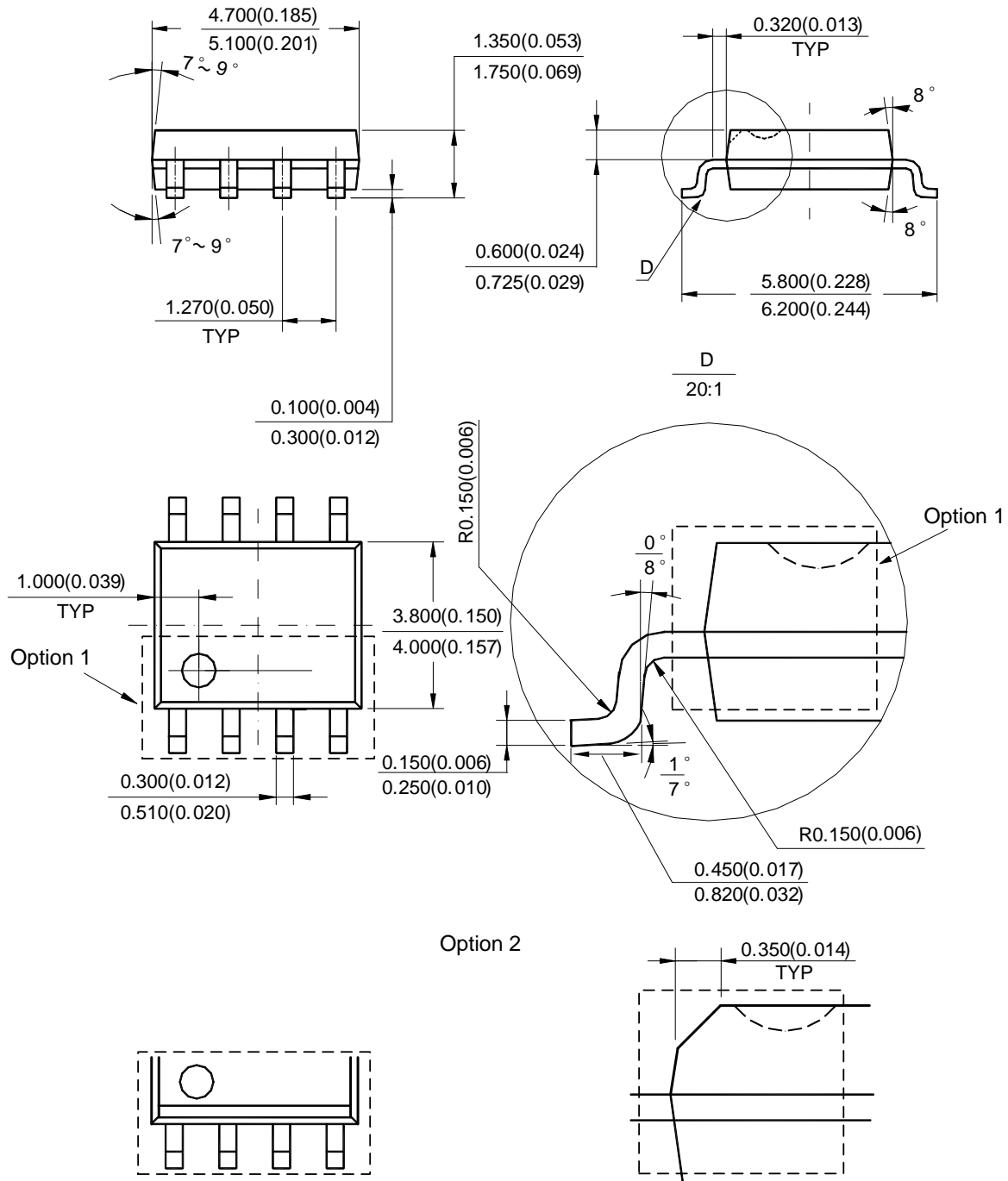

Note: Eject hole, oriented hole and mold mark is optional.

Suggested Pad Layout

(1) Package Type: SO-8

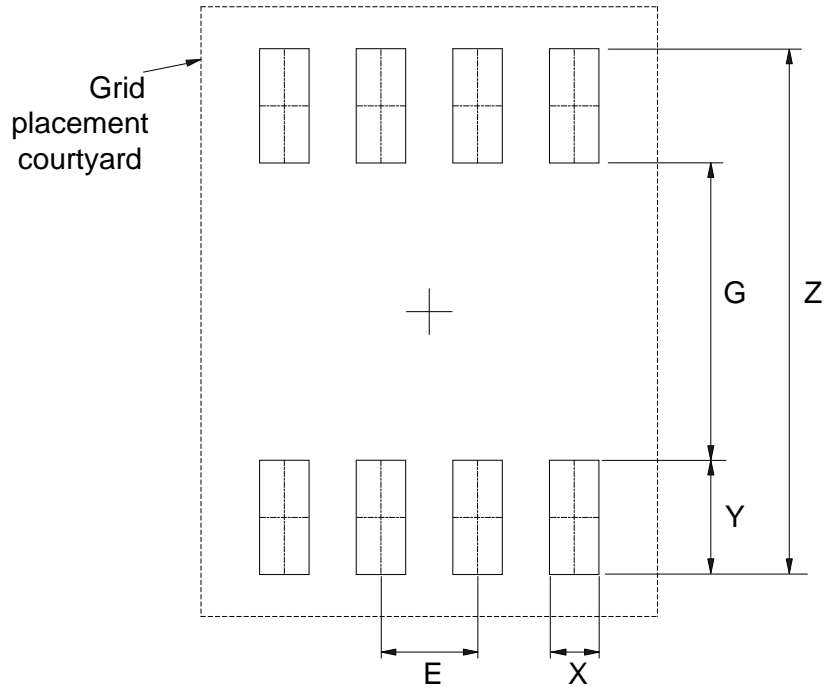

Dimensions	Z (mm)/(inch)	G (mm)/(inch)	X (mm)/(inch)	Y (mm)/(inch)	E (mm)/(inch)
Value	6.900/0.272	3.900/0.154	0.650/0.026	1.500/0.059	1.270/0.050

IMPORTANT NOTICE

DIODES INCORPORATED MAKES NO WARRANTY OF ANY KIND, EXPRESS OR IMPLIED, WITH REGARDS TO THIS DOCUMENT, INCLUDING, BUT NOT LIMITED TO, THE IMPLIED WARRANTIES OF MERCHANTABILITY AND FITNESS FOR A PARTICULAR PURPOSE (AND THEIR EQUIVALENTS UNDER THE LAWS OF ANY JURISDICTION).

Diodes Incorporated and its subsidiaries reserve the right to make modifications, enhancements, improvements, corrections or other changes without further notice to this document and any product described herein. Diodes Incorporated does not assume any liability arising out of the application or use of this document or any product described herein; neither does Diodes Incorporated convey any license under its patent or trademark rights, nor the rights of others. Any Customer or user of this document or products described herein in such applications shall assume all risks of such use and will agree to hold Diodes Incorporated and all the companies whose products are represented on Diodes Incorporated website, harmless against all damages.

Diodes Incorporated does not warrant or accept any liability whatsoever in respect of any products purchased through unauthorized sales channel. Should Customers purchase or use Diodes Incorporated products for any unintended or unauthorized application, Customers shall indemnify and hold Diodes Incorporated and its representatives harmless against all claims, damages, expenses, and attorney fees arising out of, directly or indirectly, any claim of personal injury or death associated with such unintended or unauthorized application.

Products described herein may be covered by one or more United States, international or foreign patents pending. Product names and markings noted herein may also be covered by one or more United States, international or foreign trademarks.

This document is written in English but may be translated into multiple languages for reference. Only the English version of this document is the final and determinative format released by Diodes Incorporated.

LIFE SUPPORT

Diodes Incorporated products are specifically not authorized for use as critical components in life support devices or systems without the express written approval of the Chief Executive Officer of Diodes Incorporated. As used herein:

A. Life support devices or systems are devices or systems which:

1. are intended to implant into the body, or
2. support or sustain life and whose failure to perform when properly used in accordance with instructions for use provided in the labeling can be reasonably expected to result in significant injury to the user.

B. A critical component is any component in a life support device or system whose failure to perform can be reasonably expected to cause the failure of the life support device or to affect its safety or effectiveness.

Customers represent that they have all necessary expertise in the safety and regulatory ramifications of their life support devices or systems, and acknowledge and agree that they are solely responsible for all legal, regulatory and safety-related requirements concerning their products and any use of Diodes Incorporated products in such safety-critical, life support devices or systems, notwithstanding any devices- or systems-related information or support that may be provided by Diodes Incorporated. Further, Customers must fully indemnify Diodes Incorporated and its representatives against any damages arising out of the use of Diodes Incorporated products in such safety-critical, life support devices or systems.

Copyright © 2013, Diodes Incorporated

www.diodes.com

Looking for pricing, stock, or lifecycle information?

Click below to explore more details on WIN SOURCE:

- ⊖ [View AP1684MTR-G1 on WIN SOURCE](#)
- ⊖ [Diodes Incorporated Information](#)

Optimize Your Supply Chain with WIN SOURCE Solutions

- ✓ Global Sourcing Solution
- ✓ Obsolete Management
- ✓ Cost Control Management
- ✓ Shortage Management
- ✓ Alternative Solution
- ✓ Excess Inventory Management