

320mA LED Camera Flash Driver With I²C Compatible Interface



BD6164GUT

General Description

The BD6164GUT is 320mA Flash LED driver with Synchronous rectification step up DC/DC converter that can drive 1 Flash LED.
It is possible to choice flash and torch current by I²C I/F.

Features

- Current regulation for LED
 - Flash LED Current driver (260mA, 280mA, 300mA, 320mA)
 - Assist Light Function LED Current driver (52mA, 72mA)
 - High efficiency : 85% (LED current 300mA, VBAT=3.6V, LED Vf=3.6V, 4MHz mode, Ta=25 °C)
- I²C Control I/F
- Synchronous rectification step-up DC/DC converter
 - High switching frequency 4MHz
 - Over Voltage Protection (OVP)
 - In-rush current prevention (Soft Start)
 - Over Current Protection (OCP)
 - Under Voltage Lockout (UVLO)
 - Over Temperature Protection (OTP)
 - Short-Circuit Fault detection (SCF)
- Internal generated power supply

Key Specifications

- Operating power supply voltage range: 2.7V to 4.5V
- Quiescent Current: 1µA (Typ.)
- Switching Frequency: 4.0MHz(Typ.)
- Operating temperature range: -30 to +85

Package

W(Typ.) D(Typ.) H (Max.)

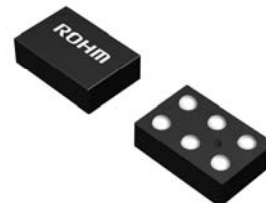

VCSP60N1
1.10mm x 1.50mm x 0.675mm

Applications

Torch light and flash for camera of mobile phone

Typical Application Circuit and Block Diagram

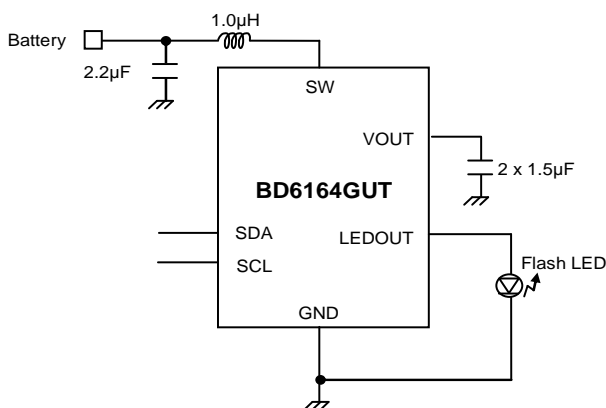

Pn Configuration

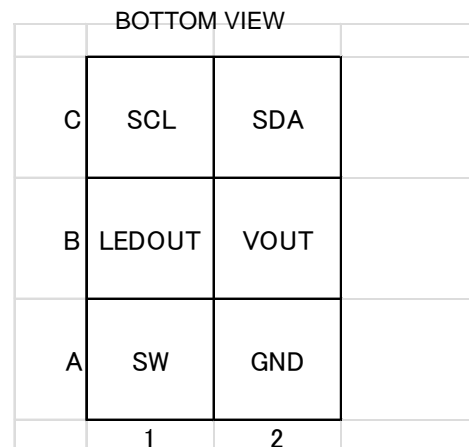

Absolute Maximum Ratings (Ta=25°C)

Parameter	Symbol	Rating	Unit
Maximum terminal voltage1 ^{*1}	VMAX1	7	V
Maximum terminal voltage2 ^{*2}	VMAX2	4.5	V
Power dissipation	Pd	550 ^{*3}	mW
Operating temperature range	Topr	-30 to +85	°C
Storage temperature range	Tstg	-55 to +150	°C

*1 for SW, VOUT, LEDOUT

*2 for SCL, SDA

*3 This value will be acquired from a sample device, mounted on a PCB by ROHM. The temperature indicates the dissipation: 6.0 mW/°C (from Ta>25 °C)

Recommended Operating Ratings (Ta=-30°C to 85°C)

Parameter	Symbol	Rating	Unit
Supply voltage	Vin	2.7 to 4.5	V

Electrical Characteristics

(Unless otherwise noted, Ta = -30°C to+85°C, Vin=2.7V to 4.5V)

Parameter	Symbol	Min.	Typ.	Max.	Units	Conditions
I²C control terminals SDA/SCL						
Low Bus voltage1	VthL1	-	-	0.1	V	
High Bus voltage1	VthH1	1.71	-	-	V	
High level Input current	IinH1	-	-	2	μA	SCL,SDA=1.8V
Low level Input current	IinL1	-2	-	-	μA	SCL,SDA=0.0V
LED driver						
Quiescent current (shutdown)	Iq,shdwn	-	1	5	μA	Shut down (SDA/SCL = 0V)
Quiescent current (stand by)	Iq,standby	-	3	9	μA	Stand by mode (SDA/SCL pull-up)
LED current accuracy	Iflash	-7	0	7	%	*2
LED current accuracy INL	INL	-1	0	1	LSB	
LED current accuracy DNL	DNL	-1	0	1	LSB	
Current source saturation voltage	Vsat	-	0.2	0.35	V	@Flash mode, LED current=300mA, VOUT=4.0V
Inductor current limit	Icoil	0.65	0.8	0.95	A	*1
Over voltage limit	Vovp	4.9	5.1	5.3	V	VOUT terminal
Output voltage range	Vorng	-	-	4.7	V	VOUT terminal
Under voltage lockout	Vuvlo	2.3	2.4	2.5	V	VOUT terminal
UVLO hysteresis	Vhys	0.05	0.1	0.15	V	
Switching frequency	Fsw	3.7	4.0	4.3	MHz	@4MHz mode

*1 This parameter is tested with DC measurement

*2 In mass production, measured in the setting that register 'ASSISTCUR'=0, 'MODE'=0

Pin Descriptions

No.	Pin Name	In/Out	Functions
A1	SW	In	Switching terminal
A2	GND	-	Ground
B1	LEDOUT	Out	LED current source. Connect to the anode of the Flash LED.
B2	VOUT	Out	Boost output. Connect output bypass capacitor very close to this pin. Vin is internally connected here.
C1	SCL	In	I ² C clock signal in I ² C mode
C2	SDA	In/Out	I ² C data signal in I ² C mode

Block Diagram

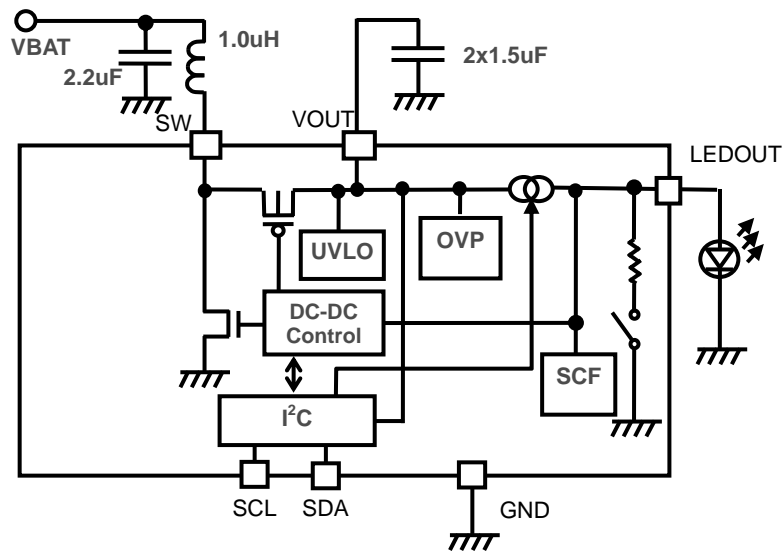

CPU I/F

The I²C I/F provides access to the Flash LED driver control registers.

- I²C BUS format

The writing/reading operation is based on the I²C slave standard.

- Slave address (60h/61h, including R/W bit)

A7	A6	A5	A4	A3	A2	A1	R/W
0	1	1	0	0	0	0	1/0

- Bit Transfer

Data is transferred when SCL=H. SCL cannot change signal of SDA during H at the time of bit transfer. If SDA changes while SCL has been H, START conditions or STOP conditions will occur and it will be interpreted as a control signal.

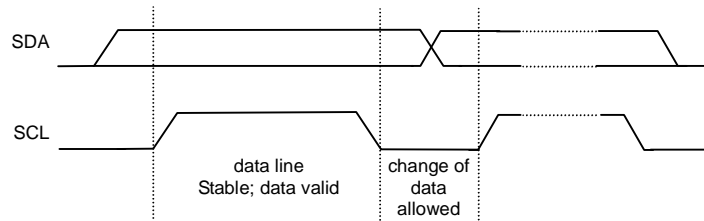

Figure 1. I²C SDA/SCL basic waveform

- START and STOP condition

When SDA and SCL are both H, data is not transferred on the I²C- bus. This condition indicates, if SDA changes from H to L while SCL has been H, it will become START (S) conditions, and an access start, if SDA changes from L to H while SCL has been H, it will become STOP (P) conditions and an access end.

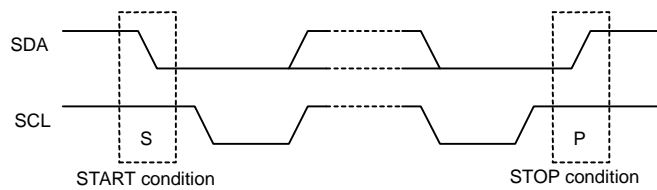

Figure 2. I²C Start/Stop condition waveform

- Acknowledge

It transfers data 8 bits each after the occurrence of START condition. A transmitter opens SDA after transfer 8bits data, and a receiver returns the acknowledge signal by setting SDA to L.

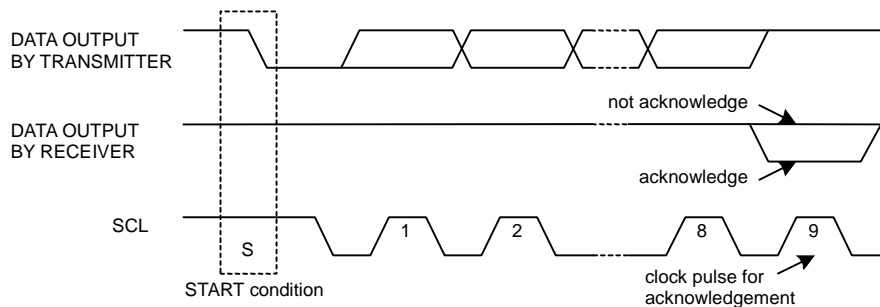

Figure 3. I²C Acknowledge waveform

◦ Writing protocol

A register address is transferred by the next 1 byte that transferred the slave address and the write-in command. The 3rd byte writes data in the internal register written in by the 2nd byte, and after 4th byte or, the increment of register address is carried out automatically. However, when a register address turns into the last address(07h), it is set to 00h by the next transmission. After the transmission end, the increment of the address is carried out.

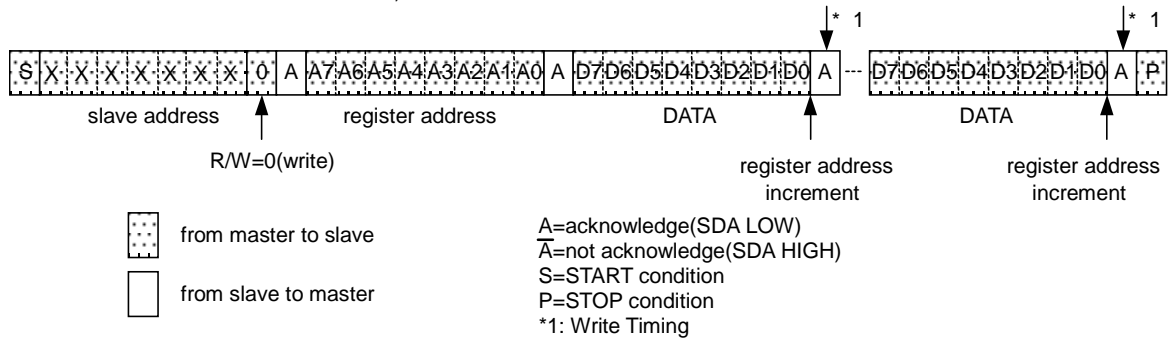

Figure 4. I²C Write protocol

◦ Reading protocol

It reads from the next byte after writing a slave address and R/W bit. The register to read considers as the following address accessed at the end, and the data of the address that carried out the increment is read after it. If an address turns into the last address(07h), the next byte will read out 00h. After the transmission end, the increment of the address is carried out.

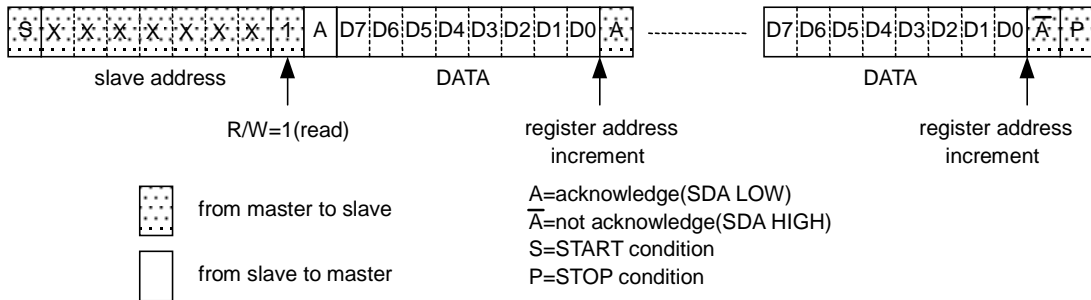

Figure 5. I²C Read protocol

◦ Multiple reading protocols

After specifying an internal address, it reads by repeated START condition and changing the data transfer direction. The data of the address that carried out the increment is read after it. If an address turns into the last address, the next byte will read out 00h. After the transmission end, the increment of the address is carried out.



Figure 6. I²C Multiple read protocol

As for reading protocol and multiple reading protocols, please do A-bar(not acknowledge) after doing the final reading operation. It stops with read when ending by A(acknowledge), and SDA stops in the state of Low when the reading data of that time is 0. However, this state returns usually when SCL is moved, data is read, and A-bar(not acknowledge)is done.

• Timing diagram

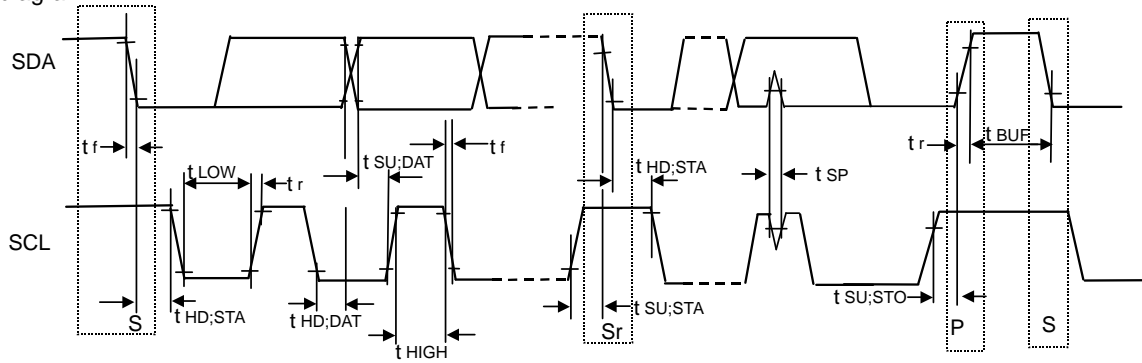

Figure 7. I²C timing diagram

• Electrical Characteristics (Unless otherwise specified, Ta=25°C, V_{TH,H1}=1.8V / V_{TH,L1}=0V)

Parameter	Symbol	Spec			Unit
		Min.	Typ.	Max.	
SCL clock frequency	f _{SCL}	0	-	400	kHz
Rise/fall times SDA/SCL	t _f / t _r	-	-	300	ns
LOW period of the SCL clock	t _{LOW}	1.3	-	-	μs
HIGH period of the SCL clock	t _{HIGH}	0.6	-	-	μs
Hold time (repeated) START condition Hold time for a repeated START condition	t _{HD:STA}	0.6	-	-	μs
Set-up time for a repeated START condition	t _{SU:STA}	0.6	-	-	μs
Data hold time	t _{HD:DAT}	0.1	-	0.9	μs
Data set-up time	t _{SU:DAT}	100	-	-	ns
Set-up time for STOP condition	t _{SU:STO}	0.6	-	-	μs
Bus free time between a STOP and START condition	t _{BUF}	1.3	-	-	μs

Register description

Register map

Name	Addr	R/W	Reset	D[7:0]									
INFO	00h	R	01010011b	MAN [3:0]					MODEL[3:0]				
VER	01h	R	00000000b	TEST[3:0]					VERSION[3:0]				
CUR	02h	R/W	10100000b	FLASHCUR[1:0]		ASSISTCUR		R	R	R	R	R	R
MOD	03h	R/W	00000100b	R	R	LEDON	MODE	TIMER[3:0]					
INT	04h	R	00000000b	OVP	SCF	OTP	R	R	R	R	R	R	

R=reserved

Address "00h", Design information register

- 1) Model ID number INFO[3:0]:

MODEL<3:0>	Function
0000 to 1111	Model id (03h)

- 2) Manufacturer ID number INFO[7:4]:

MAN<3:0>	Function
0000 to 1111	Manufacturer id (05h)

Address "01h", Version control register

- 1) Version register VER[3:0]

VERSION[3:0]	Function
0000 to 1111	Version register

- 2) Test register VER[7:4] (reserved)

TEST[3:0]	Function
0000 to 1111	Reserved

Address "02h", Current setting

- 1) Flash current CUR[7:6]

FLASHCUR[1:0]	Flash current	Default
00	260mA	
01	280mA	
10	300mA	*
11	320mA	

2) Assist Light Function current CUR[5]

ASSISTCUR	Assist light current	Default
0	52mA	
1	72mA	*

Address "03h", LED driver mode setting and timer setting

1) LED setting MOD[5]

LEDON	LED	Default
0	OFF	*
1	ON	

2) Mode setting MOD[4]

MODE	Driver state	Default
0	Assist Light	*
1	Flash	

Changing MOD[5:4] from 10 to 01, will indicate both a mode change (Assistant to Flash) and a LED deactivation. Please note that in this particular case, the mode change will trigger a flash sequence before it will deactivate the LED. To activate a Flash or Assistant, we recommend 00 to 11 (for Flash) 00 to 10 (for Assistant), and 10 to 11 (for switching Assistant to Flash).

BD6164GUT does not support switching to assistant light mode during a flash sequence.

To deactivate Flash or Assistant, we recommend to writing 00.

3) Flash timer setting MOD[3:0] (only available in flash mode)

TIMER[3:0]	tFlash	Default
0000	30ms	
0001	60ms	
0010	90ms	
0011	120ms	
0100	150ms	*
0101	180ms	
0110	210ms	
0111	240ms	
1000	270ms	
1001	300ms	
1010	330ms	
1011	360ms	
1100	390ms	
1101	420ms	
1110	450ms	
1111	480ms	

Address "04h", Interrupt register

1) Over Voltage protection INT[7]

OVP	Status	Default
0	OK	*
1	Fault	

2) Short Circuit Fault INT[6]:

SCF	Status	Default
0	OK	*
1	Fault	

3) Over Temperature Protection INT[5]:

OTP	Status	Default
0	OK	*
1	Fault	

Functional Description

1. Start up sequence

After waking up from sleep-mode, the LED current is ramped up and down in a controlled way in order to avoid massive inrush current and proper initialization of the current regulation loop. The maximum current (320mA) should be reached within 0.6-1.0ms. Since this process is controlled by the oscillator, the minimum no. of clock cycles (1MHz+7.5%) is 645 (worst-case).

1) Flash mode

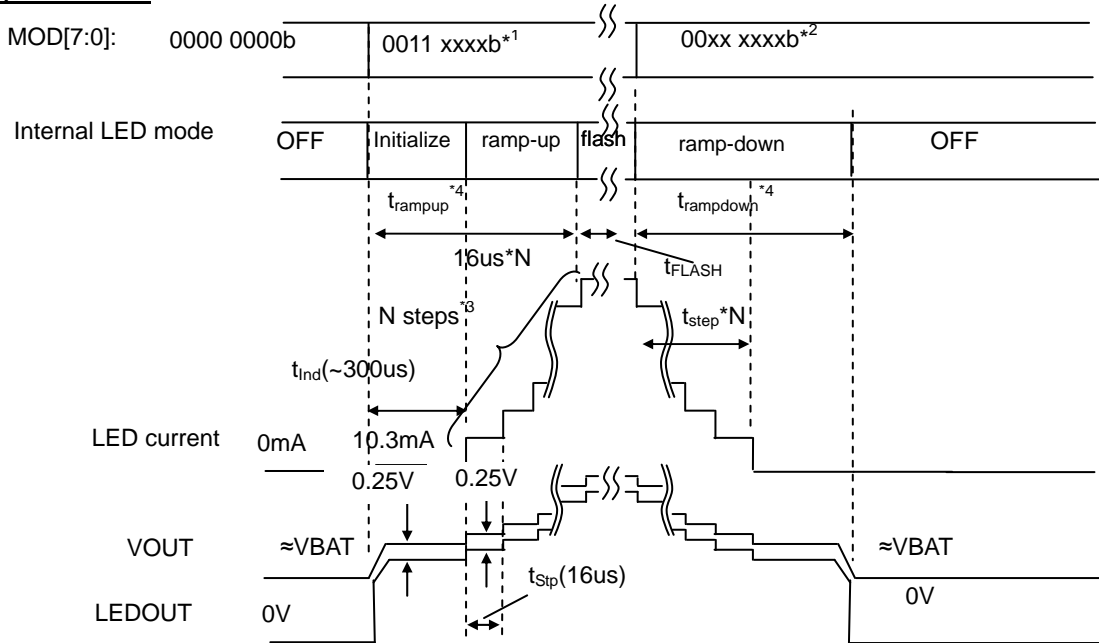

*1: MOD<3:0> indicates the programmed flash time
 *2: MOD[5:4] is reset (LED off) when timer is expired or by S/W (during LED flash, no new flash is accepted)
 *3: N=programmed flash current / I_step (= I_LED,max/(2^K-1)=10.3mA, K=5 bits)
 *4: t_ramp-up= t_initialize + N*T_step. (T_step= T_rmp,max/(2^K-1)=496us/31=16us, K=5 bits). t_ramp-down= (N+1)*T_step
 *5: In case that the system goes to transparency mode during ramp down phase, the system does not start boost up.

Figure 8. Ramp-up/down (Flash)

2) Assist Light mode

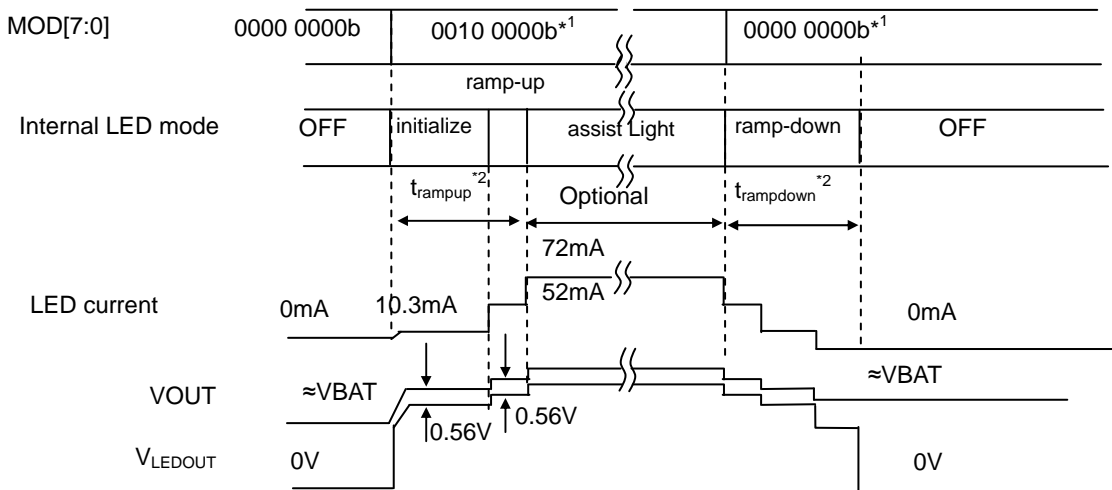

*1: In Assist Light mode, the LED is enabled until register ASSIST is reset by S/W or when a flash command is issued
 *2: t_ramp-up= t_initialize + N*16us (N=4..6, 1st step=initialize), t_ramp-down= N*16us (N=5..7, to zero)
 *3: In case that the system goes to transparency mode during ramp down phase, the system does not start boost up.

Figure 9. Ramp-up/down (Assistant light)

3. Over Temperature Protection (OTP)

BD6164GUT has an over-temperature protection function (Thermal shut down). When the die-temperature over 150 degrees, a shutdown-sequence is started:

- 1) Set OTP interrupt
- 2) Shutdown DCDC and LED driver.
- 3) Wait for the die-temperature to drop below 130 degrees and the interrupt to be cleared by S/W (register read) before allowing new LED activity.

4. Over Voltage Protection (OVP)

In order to prevent damage to the chip, Over Voltage Protection (OVP) detection is implemented. When the output voltage exceeds 5.3V, a shut-down sequence is started:

- 1) Set OVP interrupt
- 2) Stop the switching of the DCDC and go to stand by mode and the register "LEDON" turns to '0'
- 3) Then OVP register is written as '1'. This register is to be cleared by being read by S/W.

5. Short Circuit Fault detection (SCF)

After LED driver had started, BD6164GUT detects the LEDOUT voltage. If the voltage is under (1.2)V, the following actions are taken:

- 1) Set SCF interrupt
- 2) Shutdown DCDC and LED driver.
- 3) Wait for the SCF register to be cleared by S/W (register read) before allowing new LED activity.

6. Under-Voltage Lock Out

In this system, the under-voltage lockout function is performing a self-test by monitoring the voltage on the VOUT node just before starting up the step-up DCDC converter. This ensures that any LED activity is blocked when the battery voltage is too low. During boost up, the system is not able to accurately detect the battery voltage (no separate VBAT pin on the chip), so the UVLO is disabled. In case of an under voltage situation, there is no need to set an interrupt register.

7. The DCDC mode.

The DCDC boost converter has three operational modes^{*1} that provide the supply voltage for the LED driver:

- 1) 4MHz PWM switching mode: when boost-up ratio is high enough to ensure a correct and stable current regulation loop ($V_{BAT} \ll V_{OUT}$). In the assistant light mode, system doesn't go to this mode.
- 2) 1MHz PWM switching mode: used in case that the boost-up ratio (duty-cycle) becomes too small ($V_{BAT} \approx V_{OUT}$) for the current regulation to operate properly.
- 3) Transparent mode: used when the battery voltage exceeds the required LED driver supply voltage

^{*1} Transitions between these operational modes are determined by the headroom voltage (i.e. voltage across LED current switch) and the actual PWM duty-cycle information.

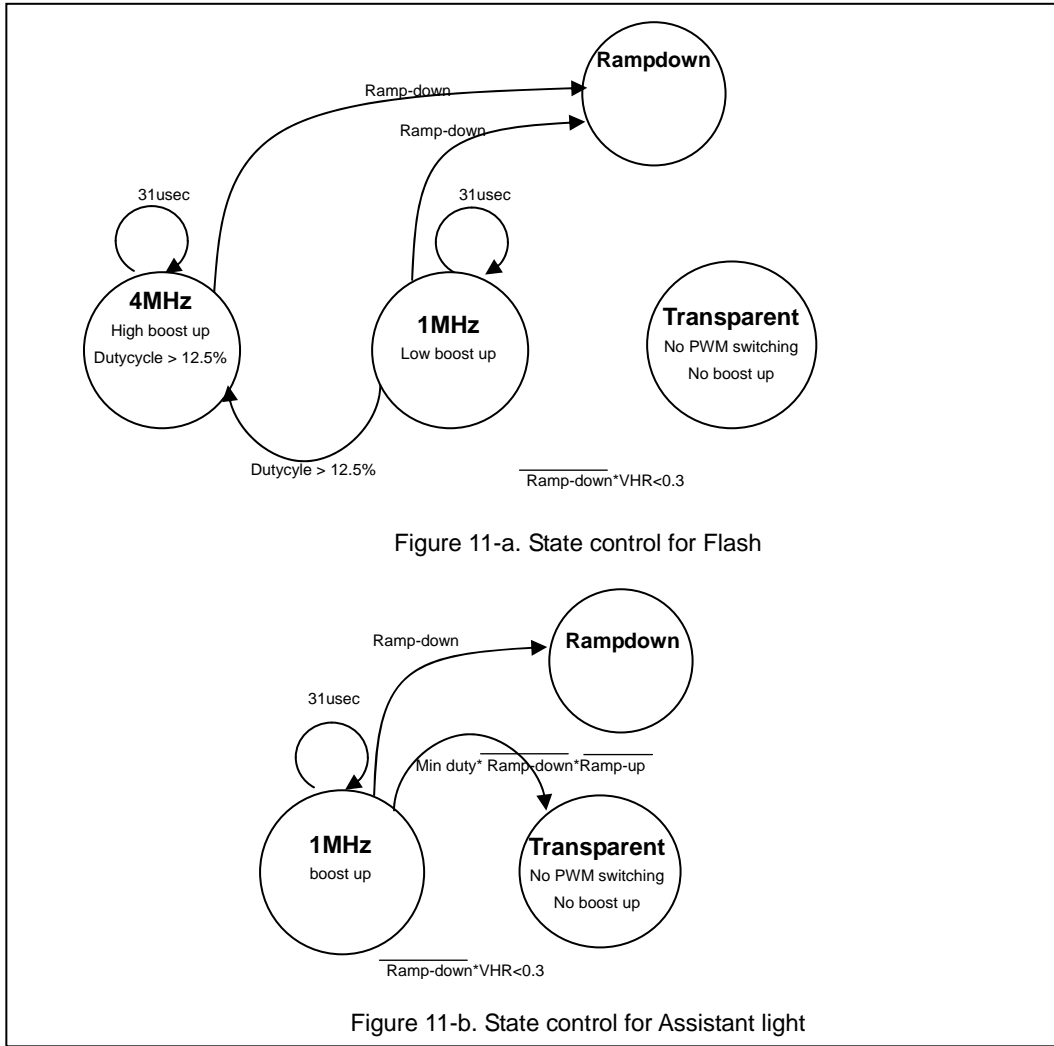

8. Discharge function

When the LED is turned off and the LED current has been ramped down, the DCDC converter is turned off. If at that point the voltage on the VOUT node still exceeds the battery-voltage, it needs to be discharged to the battery voltage level. This will be achieved by adding a discharge switch in parallel to the PMOS switch of the DCDC boost converter.

During ramping down, DCDC doesn't change the state. After ramp down system goes to stand-by mode.)

9. Recommended external components

Coil

Value	Vendor	Parts number	Size			DCR (Ω)
			X	Y	Z	
1.0uH	TOKO	MDT2012-CN1R0	2.0	1.2	1.0	0.15
1.0uH	Murata	LQM21PN1R0NGC	2.0	1.25	0.5	0.19
1.0uH	Samsung	CIG21K1R0SCE	2.0	1.25	0.9	-

Capacitor

Value	Vendor	Parts number
Cin		
4.7uF	Samsung	CL05A395MQ5NQKL
Cout		
2x1.5μF	Samsung	CL14A185MQ8SAKL

10. Operational Notes

(1) Absolute Maximum Ratings

An excess in the absolute maximum ratings, such as supply voltage, temperature range of operating conditions, etc., can break down devices, thus making impossible to identify breaking mode such as a short circuit or an open circuit. If any special mode exceeding the absolute maximum ratings is assumed, consideration should be given to take physical safety measures including the use of fuses, etc.

(2) Operating conditions

These conditions represent a range within which characteristics can be provided approximately as expected. The electrical characteristics are guaranteed under the conditions of each parameter.

(3) Reverse connection of power supply connector

The reverse connection of power supply connector can break down ICs. Take protective measures against the breakdown due to the reverse connection, such as mounting an external diode between the power supply and the IC's power supply terminal.

(4) Power supply line

Design PCB pattern to provide low impedance for the wiring between the power supply and the GND lines. In this regard, for the digital block power supply and the analog block power supply, even though these power supplies has the same level of potential, separate the power supply pattern for the digital block from that for the analog block, thus suppressing the diffraction of digital noises to the analog block power supply resulting from impedance common to the wiring patterns.

For the GND line, give consideration to design the patterns in a similar manner.

Furthermore, for all power supply terminals to ICs, mount a capacitor between the power supply and the GND terminal. At the same time, in order to use an electrolytic capacitor, thoroughly check to be sure the characteristics of the capacitor to be used present no problem including the occurrence of capacity dropout at a low temperature, thus determining the constant.

(5) GND voltage

Make setting of the potential of the GND terminal so that it will be maintained at the minimum in any operating state. Furthermore, check to be sure no terminals are at a potential lower than the GND voltage including an actual electric transient.

(6) Short circuit between terminals and erroneous mounting

In order to mount ICs on a set PCB, pay thorough attention to the direction and offset of the ICs. Erroneous mounting can break down the ICs. Furthermore, if a short circuit occurs due to foreign matters entering between terminals or between the terminal and the power supply or the GND terminal, the ICs can break down.

(7) Operation in strong electromagnetic field

Be noted that using ICs in the strong electromagnetic field can malfunction them.

(8) Inspection with set PCB

On the inspection with the set PCB, if a capacitor is connected to a low-impedance IC terminal, the IC can suffer stress. Therefore, be sure to discharge from the set PCB by each process. Furthermore, in order to mount or dismount the set PCB to/from the jig for the inspection process, be sure to turn OFF the power supply and then mount the set PCB to the jig. After the completion of the inspection, be sure to turn OFF the power supply and then dismount it from the jig. In addition, for protection against static electricity, establish a ground for the assembly process and pay thorough attention to the transportation and the storage of the set PCB.

(9) Input terminals

In terms of the construction of IC, parasitic elements are inevitably formed in relation to potential. The operation of the parasitic element can cause interference with circuit operation, thus resulting in a malfunction and then breakdown of the input terminal. Therefore, pay thorough attention not to handle the input terminals, such as to apply to the input terminals a voltage lower than the GND respectively, so that any parasitic element will operate. Furthermore, do not apply a voltage to the input terminals when no power supply voltage is applied to the IC. In addition, even if the power supply voltage is applied, apply to the input terminals a voltage lower than the power supply voltage or within the guaranteed value of electrical characteristics.

(10) Ground wiring pattern

If small-signal GND and large-current GND are provided, It will be recommended to separate the large-current GND pattern from the small-signal GND pattern and establish a single ground at the reference point of the set PCB so that resistance to the wiring pattern and voltage fluctuations due to a large current will cause no fluctuations in voltages of the small-signal GND. Pay attention not to cause fluctuations in the GND wiring pattern of external parts as well.

(11) External capacitor

In order to use a ceramic capacitor as the external capacitor, determine the constant with consideration given to a degradation in the nominal capacitance due to DC bias and changes in the capacitance due to temperature, etc.

(12) Thermal shutdown circuit (TSD)

When junction temperatures become 150°C (typ) or higher, the thermal shutdown circuit operates and turns a switch OFF. The thermal shutdown circuit, which is aimed at isolating the LSI from thermal runaway as much as possible, is not aimed at the protection or guarantee of the LSI. Therefore, do not continuously use the LSI with this circuit operating or use the LSI assuming its operation.

(13) Thermal design

Perform thermal design in which there are adequate margins by taking into account the permissible dissipation (Pd) in actual states of use.

(14) Selection of coil

Select the low DCR inductors to decrease power loss for DC/DC converter.

Ordering Information

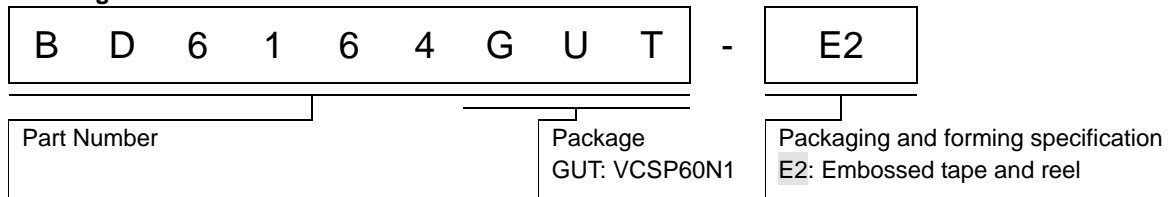

Marking Diagram

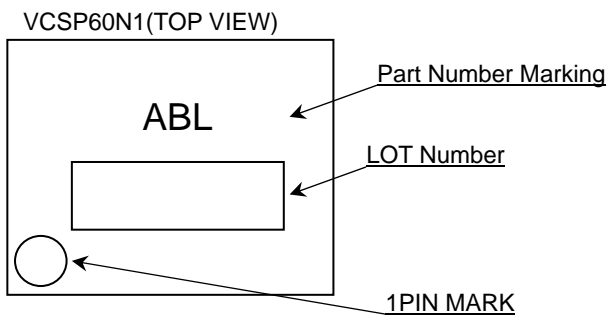

Revision History

Date	Revision	Changes
21.Dec.2012	001	New Release

Notice

Precaution on using ROHM Products

- Our Products are designed and manufactured for application in ordinary electronic equipments (such as AV equipment, OA equipment, telecommunication equipment, home electronic appliances, amusement equipment, etc.). If you intend to use our Products in devices requiring extremely high reliability (such as medical equipment ^(Note 1), transport equipment, traffic equipment, aircraft/spacecraft, nuclear power controllers, fuel controllers, car equipment including car accessories, safety devices, etc.) and whose malfunction or failure may cause loss of human life, bodily injury or serious damage to property ("Specific Applications"), please consult with the ROHM sales representative in advance. Unless otherwise agreed in writing by ROHM in advance, ROHM shall not be in any way responsible or liable for any damages, expenses or losses incurred by you or third parties arising from the use of any ROHM's Products for Specific Applications.

(Note1) Medical Equipment Classification of the Specific Applications

JAPAN	USA	EU	CHINA
CLASS III	CLASS III	CLASS II b	CLASS III
CLASS IV		CLASS III	

- ROHM designs and manufactures its Products subject to strict quality control system. However, semiconductor products can fail or malfunction at a certain rate. Please be sure to implement, at your own responsibilities, adequate safety measures including but not limited to fail-safe design against the physical injury, damage to any property, which a failure or malfunction of our Products may cause. The following are examples of safety measures:
 - Installation of protection circuits or other protective devices to improve system safety
 - Installation of redundant circuits to reduce the impact of single or multiple circuit failure
- Our Products are designed and manufactured for use under standard conditions and not under any special or extraordinary environments or conditions, as exemplified below. Accordingly, ROHM shall not be in any way responsible or liable for any damages, expenses or losses arising from the use of any ROHM's Products under any special or extraordinary environments or conditions. If you intend to use our Products under any special or extraordinary environments or conditions (as exemplified below), your independent verification and confirmation of product performance, reliability, etc. prior to use, must be necessary:
 - Use of our Products in any types of liquid, including water, oils, chemicals, and organic solvents
 - Use of our Products outdoors or in places where the Products are exposed to direct sunlight or dust
 - Use of our Products in places where the Products are exposed to sea wind or corrosive gases, including Cl₂, H₂S, NH₃, SO₂, and NO₂
 - Use of our Products in places where the Products are exposed to static electricity or electromagnetic waves
 - Use of our Products in proximity to heat-producing components, plastic cords, or other flammable items
 - Sealing or coating our Products with resin or other coating materials
 - Use of our Products without cleaning residue of flux (even if you use no-clean type fluxes, cleaning residue of flux is recommended); or Washing our Products by using water or water-soluble cleaning agents for cleaning residue after soldering
 - Use of the Products in places subject to dew condensation
- The Products are not subject to radiation-proof design.
- Please verify and confirm characteristics of the final or mounted products in using the Products.
- In particular, if a transient load (a large amount of load applied in a short period of time, such as pulse. is applied, confirmation of performance characteristics after on-board mounting is strongly recommended. Avoid applying power exceeding normal rated power; exceeding the power rating under steady-state loading condition may negatively affect product performance and reliability.
- De-rate Power Dissipation (Pd) depending on Ambient temperature (Ta). When used in sealed area, confirm the actual ambient temperature.
- Confirm that operation temperature is within the specified range described in the product specification.
- ROHM shall not be in any way responsible or liable for failure induced under deviant condition from what is defined in this document.

Precaution for Mounting / Circuit board design

- When a highly active halogenous (chlorine, bromine, etc.) flux is used, the residue of flux may negatively affect product performance and reliability.
- In principle, the reflow soldering method must be used; if flow soldering method is preferred, please consult with the ROHM representative in advance.

For details, please refer to ROHM Mounting specification

Precautions Regarding Application Examples and External Circuits

1. If change is made to the constant of an external circuit, please allow a sufficient margin considering variations of the characteristics of the Products and external components, including transient characteristics, as well as static characteristics.
2. You agree that application notes, reference designs, and associated data and information contained in this document are presented only as guidance for Products use. Therefore, in case you use such information, you are solely responsible for it and you must exercise your own independent verification and judgment in the use of such information contained in this document. ROHM shall not be in any way responsible or liable for any damages, expenses or losses incurred by you or third parties arising from the use of such information.

Precaution for Electrostatic

This Product is electrostatic sensitive product, which may be damaged due to electrostatic discharge. Please take proper caution in your manufacturing process and storage so that voltage exceeding the Products maximum rating will not be applied to Products. Please take special care under dry condition (e.g. Grounding of human body / equipment / solder iron, isolation from charged objects, setting of Ionizer, friction prevention and temperature / humidity control).

Precaution for Storage / Transportation

1. Product performance and soldered connections may deteriorate if the Products are stored in the places where:
 - [a] the Products are exposed to sea winds or corrosive gases, including Cl₂, H₂S, NH₃, SO₂, and NO₂
 - [b] the temperature or humidity exceeds those recommended by ROHM
 - [c] the Products are exposed to direct sunshine or condensation
 - [d] the Products are exposed to high Electrostatic
2. Even under ROHM recommended storage condition, solderability of products out of recommended storage time period may be degraded. It is strongly recommended to confirm solderability before using Products of which storage time is exceeding the recommended storage time period.
3. Store / transport cartons in the correct direction, which is indicated on a carton with a symbol. Otherwise bent leads may occur due to excessive stress applied when dropping of a carton.
4. Use Products within the specified time after opening a humidity barrier bag. Baking is required before using Products of which storage time is exceeding the recommended storage time period.

Precaution for Product Label

QR code printed on ROHM Products label is for ROHM's internal use only.

Precaution for Disposition

When disposing Products please dispose them properly using an authorized industry waste company.

Precaution for Foreign Exchange and Foreign Trade act

Since our Products might fall under controlled goods prescribed by the applicable foreign exchange and foreign trade act, please consult with ROHM representative in case of export.

Precaution Regarding Intellectual Property Rights

1. All information and data including but not limited to application example contained in this document is for reference only. ROHM does not warrant that foregoing information or data will not infringe any intellectual property rights or any other rights of any third party regarding such information or data. ROHM shall not be in any way responsible or liable for infringement of any intellectual property rights or other damages arising from use of such information or data.:
2. No license, expressly or implied, is granted hereby under any intellectual property rights or other rights of ROHM or any third parties with respect to the information contained in this document.

Other Precaution



1. This document may not be reprinted or reproduced, in whole or in part, without prior written consent of ROHM.
2. The Products may not be disassembled, converted, modified, reproduced or otherwise changed without prior written consent of ROHM.
3. In no event shall you use in any way whatsoever the Products and the related technical information contained in the Products or this document for any military purposes, including but not limited to, the development of mass-destruction weapons.
4. The proper names of companies or products described in this document are trademarks or registered trademarks of ROHM, its affiliated companies or third parties.

General Precaution

1. Before you use our Products, you are requested to carefully read this document and fully understand its contents. ROHM shall not be in any way responsible or liable for failure, malfunction or accident arising from the use of any ROHM's Products against warning, caution or note contained in this document.
2. All information contained in this document is current as of the issuing date and subject to change without any prior notice. Before purchasing or using ROHM's Products, please confirm the latest information with a ROHM sales representative.
3. The information contained in this document is provided on an "as is" basis and ROHM does not warrant that all information contained in this document is accurate and/or error-free. ROHM shall not be in any way responsible or liable for any damages, expenses or losses incurred by you or third parties resulting from inaccuracy or errors of or concerning such information.

Looking for pricing, stock, or lifecycle information?

Click below to explore more details on WIN SOURCE:

-  [View BD6164GUT-E2 on WIN SOURCE](#)
-  [Rohm Semiconductor](#) Information

Optimize Your Supply Chain with WIN SOURCE Solutions

-  Global Sourcing Solution
-  Obsolete Management
-  Cost Control Management
-  Shortage Management
-  Alternative Solution
-  Excess Inventory Management