

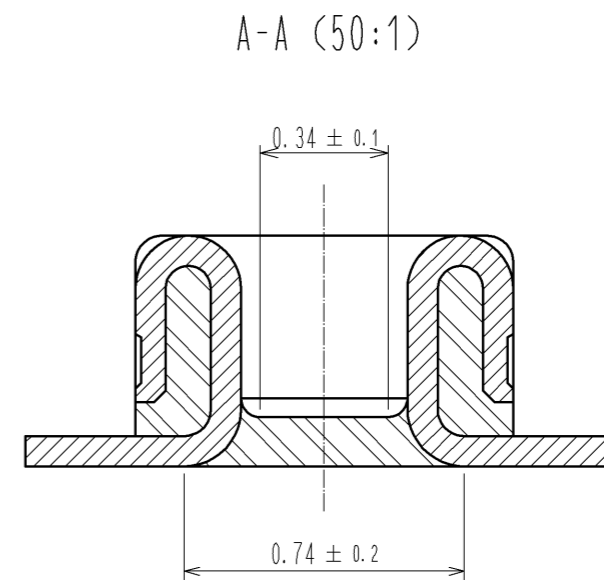

**THE DATASHEET OF
BM14B(0.8)-10DP-0.4V(51)**

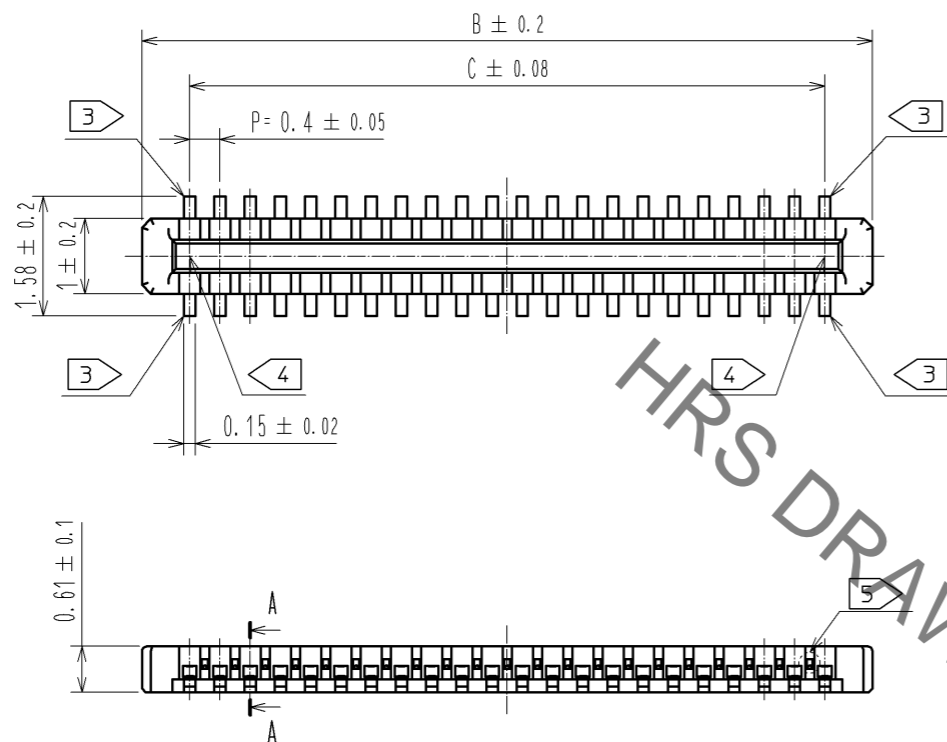

Aug.1.2019 Copyright 2019 HIROSE ELECTRIC CO., LTD. All Rights Reserved.
In case of consideration for using Automotive equipment / device which demand high reliability, kindly contact our sales window correspondents.



- NOTE) 1. ALL LEAD CO-PLANARITY SHALL BE 0.08mm MAX
 2. CONTACT PLATING SPECIFICATIONS
 CONTACT AREA : GOLD 0.05 μm MIN
 SMT LEAD : GOLD 0.05 μm MIN
 UNDERPLATING : NICKEL 1 μm MIN
 (SURFACE : SEALING)
 3. EACH CONTACTS AT 4 CORNERS ARE PROVIDED FOR METAL FITTINGS AND GROUNDING PURPOSE. THEY CAN BE USED ALSO AS A SIGNAL CONTACT.
 4. HRS MARK AND CAV No. ARE INDICATED IN APPROX POSITION SHOWN.
 5. A PART OF THE WALL COULD BE NOTCHED.

ENGAGEMENT FIGURE (50:1)

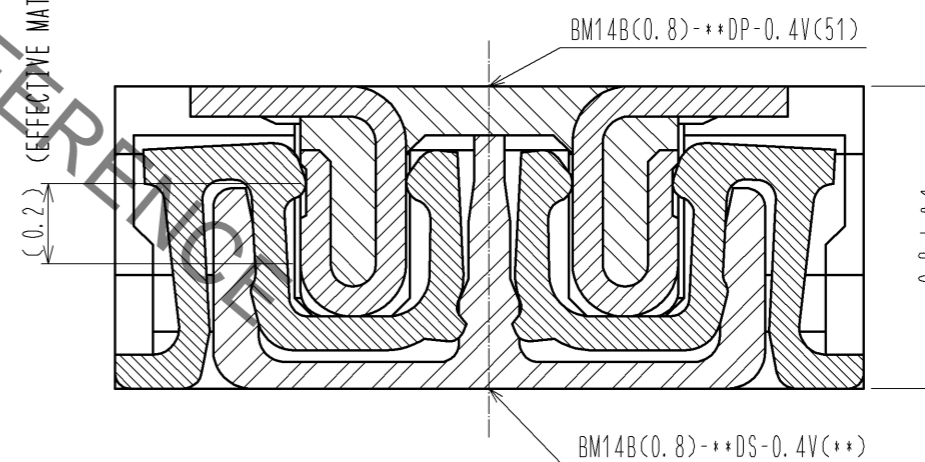

PART No.	CODE No.	B	C
BM14B(0.8)-10DP-0.4V(51)	CL684-8010-0-51	3.66	2.4
BM14B(0.8)-12DP-0.4V(51)	CL684-8042-7-51	4.06	2.8
BM14B(0.8)-20DP-0.4V(51)	CL684-8011-3-51	5.66	4.4
BM14B(0.8)-22DP-0.4V(51)	CL684-8047-0-51	6.06	4.8
BM14B(0.8)-24DP-0.4V(51)	CL684-8012-6-51	6.46	5.2
BM14B(0.8)-30DP-0.4V(51)	CL684-8013-9-51	7.66	6.4
BM14B(0.8)-34DP-0.4V(51)	CL684-8014-1-51	8.46	7.2
BM14B(0.8)-40DP-0.4V(51)	CL684-8015-4-51	9.66	8.4
BM14B(0.8)-50DP-0.4V(51)	CL684-8016-7-51	11.66	10.4
BM14B(0.8)-60DP-0.4V(51)	CL684-8002-2-51	13.66	12.4

NO.	MATERIAL	FINISH	REMARKS	NO.	MATERIAL	FINISH	REMARKS
3	PS		CLEAR (ENBOSSED CARRIER TAPE)	6	PS		CLEAR (REINFORCEMENT COLLAR)
2	PHOSPHOR BRONZE		2	5	PS		BLACK (PLASTIC REEL)
1	LCP		UL94 V-0, BLACK	4	POLYESTER		CLEAR (COVER TAPE)

UNITS	SCALE	COUNT	DESCRIPTION OF REVISIONS	DESIGNED	CHECKED	DATE
mm	10:1	1	DIS-H-008082	SH. HOSODA	YH. MICHIDA	13.08.03

APPROVED	DATE	DRAWING NO.
KH. IKEDA	09.11.24	EDC3-322328-04
WR. FUKUCHI	09.11.24	PART NO.
YH. HASEGAWA	09.11.20	BM14B(0.8)-*DP-0.4V(51)
YH. HASEGAWA	09.11.20	CODE NO.
		CL684

Aug.1.2019 Copyright 2019 HIROSE ELECTRIC CO., LTD. All Rights Reserved.
In case of consideration for using Automotive equipment / device which demand high reliability, kindly contact our sales window correspondents.

◆ RECOMMENDED PCB LAYOUT

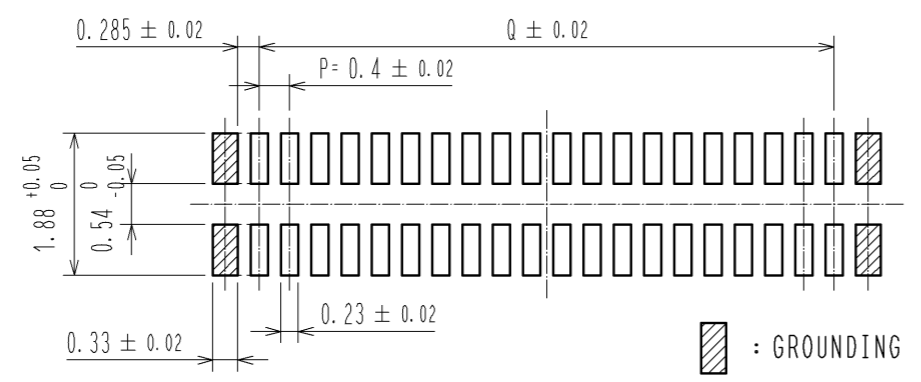

◆ RECOMMENDED METAL MASK DIMENSIONS

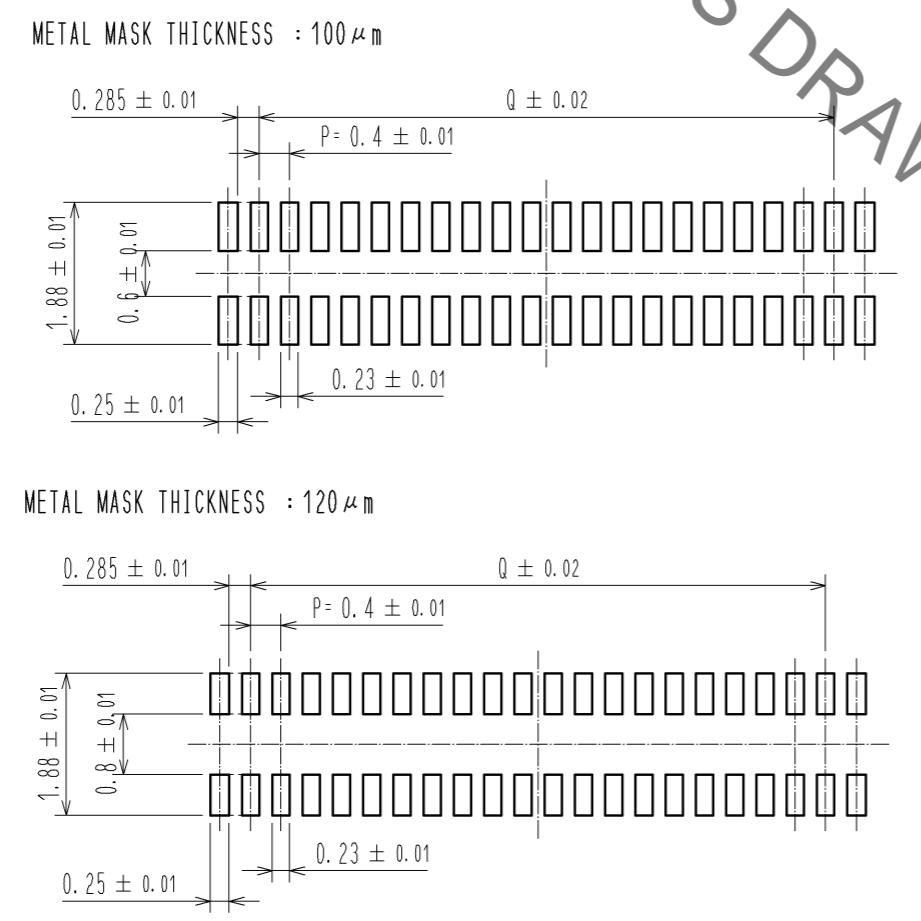

PART No.	Q
BM14B(0.8)-10DP-0.4V(51)	1.6
BM14B(0.8)-12DP-0.4V(51)	2.0
BM14B(0.8)-20DP-0.4V(51)	3.6
BM14B(0.8)-22DP-0.4V(51)	4.0
BM14B(0.8)-24DP-0.4V(51)	4.4
BM14B(0.8)-30DP-0.4V(51)	5.6
BM14B(0.8)-34DP-0.4V(51)	6.4
BM14B(0.8)-40DP-0.4V(51)	7.6
BM14B(0.8)-50DP-0.4V(51)	9.6
BM14B(0.8)-60DP-0.4V(51)	11.6

⑥ RECOMMENDED REFLOW TEMPERATURE PROFILE USING LEAD-FREE SOLDER PASTE.

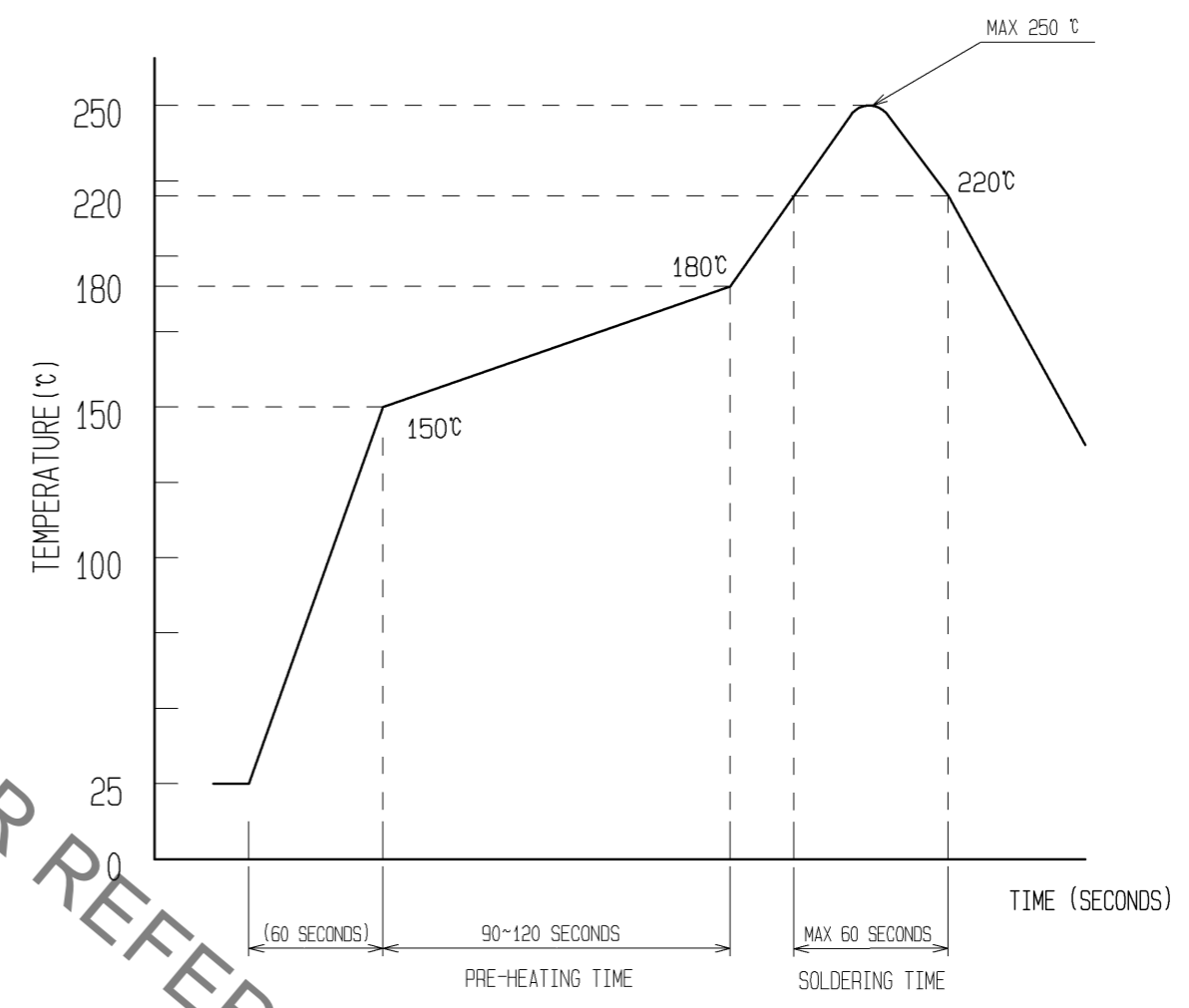

REFLOW METHOD: IR REFLOW
 NUMBER OF REFLOW CYCLES: 2 CYCLES MAX.
 1) REFLOW TIME
 DURATION ABOVE 220°C, 60 SEC. MAX.
 (PEAK TEMPERATURE: 250°C MAX)
 2) PRE-HEAT TIME
 PRE-HEAT TEMPERATURE(MIN): 150°C
 PRE-HEAT TEMPERATURE(MAX): 180°C
 PRE-HEAT TIME: 90-120 sec.

⑥ THIS TEMPERATURE PROFILE IS PER THE CONDITIONS SHOWN ABOVE. ADDITIONAL FACTORS, SUCH AS SOLDER PASTE TYPE, PCB SIZE AND OTHER MOUNTED COMPONENTS COULD AFFECT THE PROFILE, THEREFORE, A THOROUGH EVALUATION OF MOUNTING CONDITION IS REQUIRED PRIOR TO PRODUCTION. TEMPERATURE IS MEASURED AT CONTACT LEAD.

HRS	DRAWING NO.	EDC3-322328-04
	PART NO.	BM14B(0.8)-*DP-0.4V(51)
	CODE NO.	CL684

Aug.1.2019 Copyright 2019 HIROSE ELECTRIC CO., LTD. All Rights Reserved.
In case of consideration for using Automotive equipment / device which demand high reliability, kindly contact our sales window correspondents.

EMBOSSED CARRIER TAPE PACKAGING (5:1)

STYLE AND DIMENTION OF REEL (FREE)

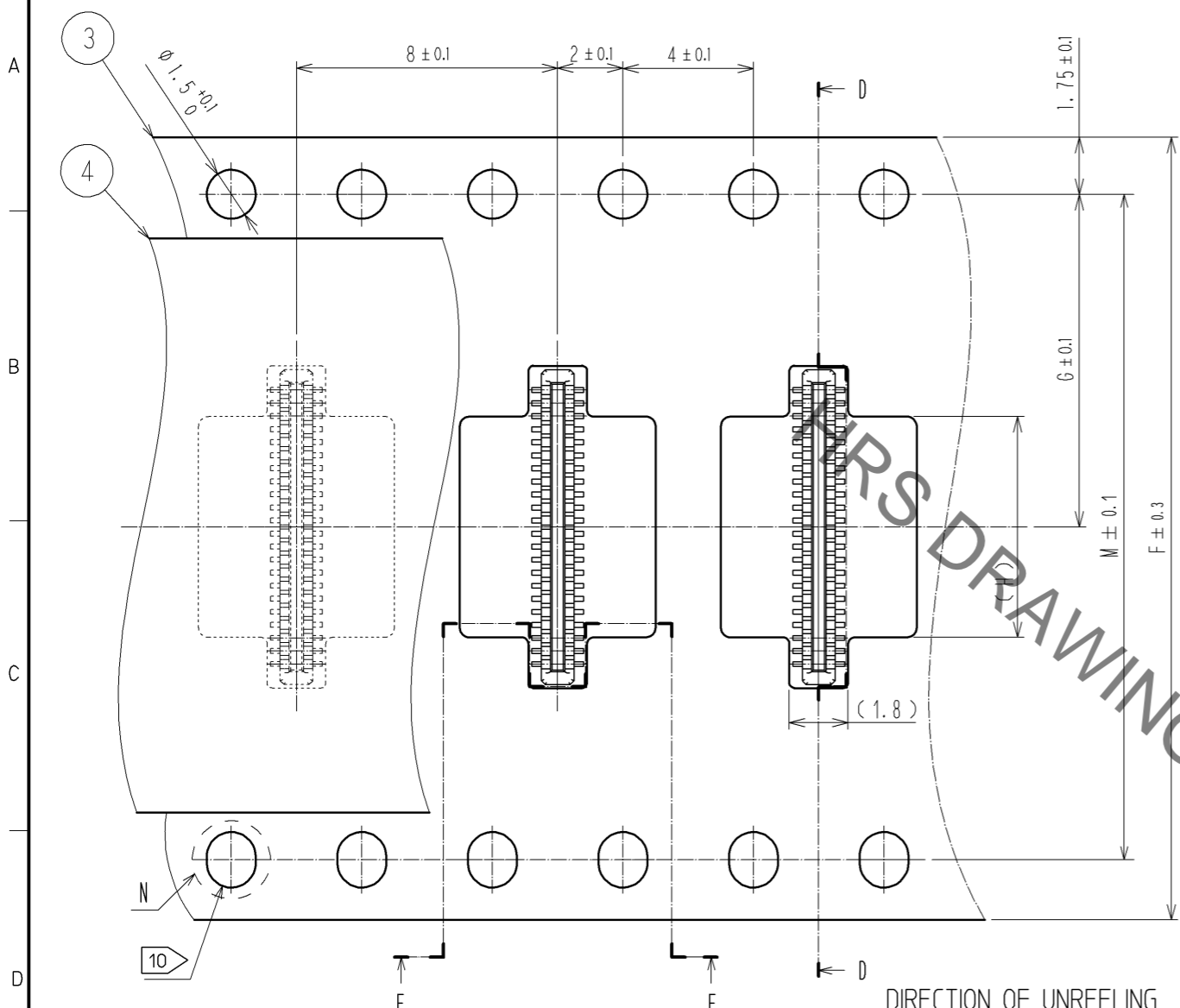

D-D (5:1)

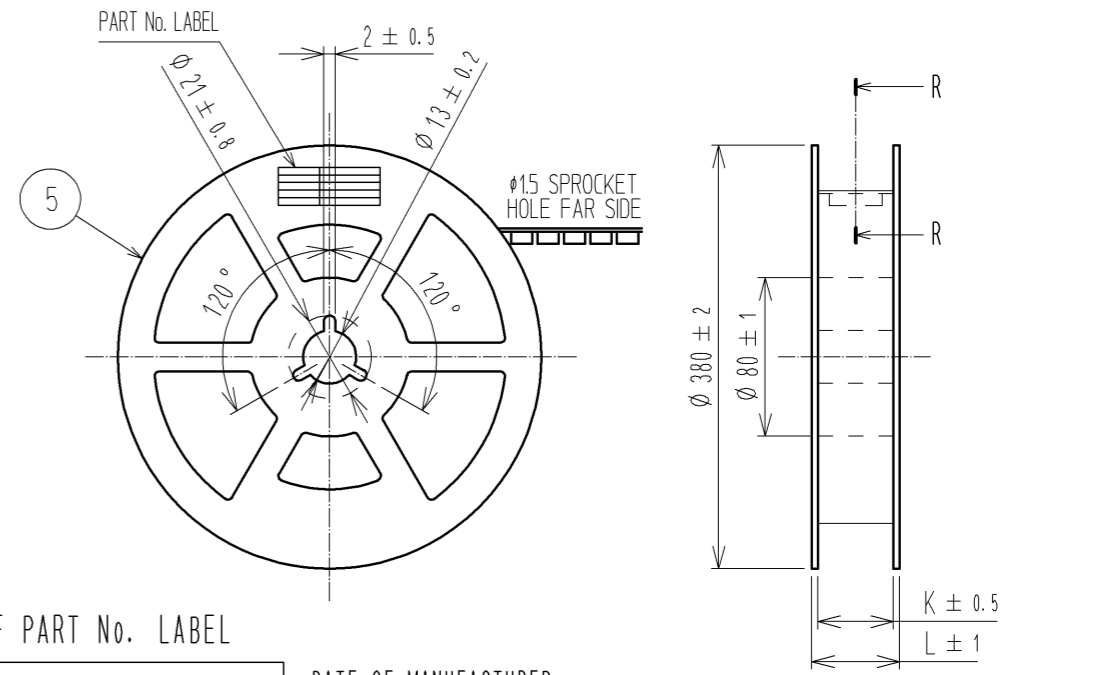
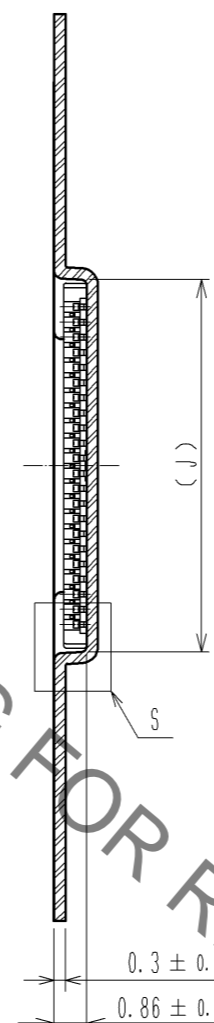

DETAIL OF PART No. LABEL

製造年月日	** ** *	DATE OF MANUFACTURED
製品コード	CL684-****-**-**	CODE No.
製品名	BM14B(0.8)-*DP-0.4V(51)	PART No.
数量	8,000	QUANTITY
納入者	ヒロセ電機(株)	SUPPLIER

DATE OF MANUFACTURED
CODE No.
PART No.
QUANTITY
SUPPLIER

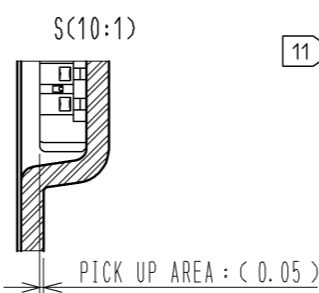
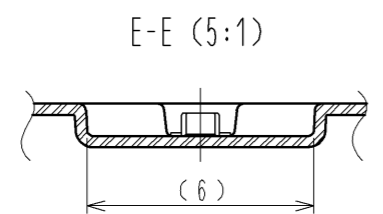
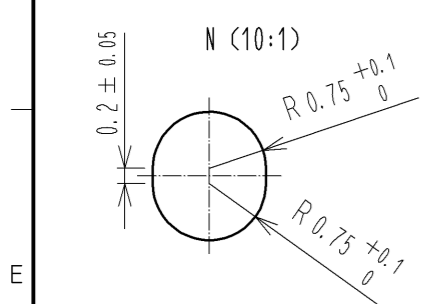
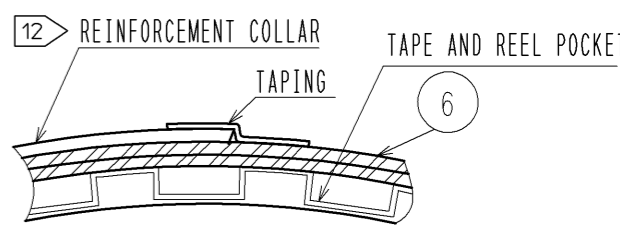

11 10 POS AND 12POS POCKET SHAPE

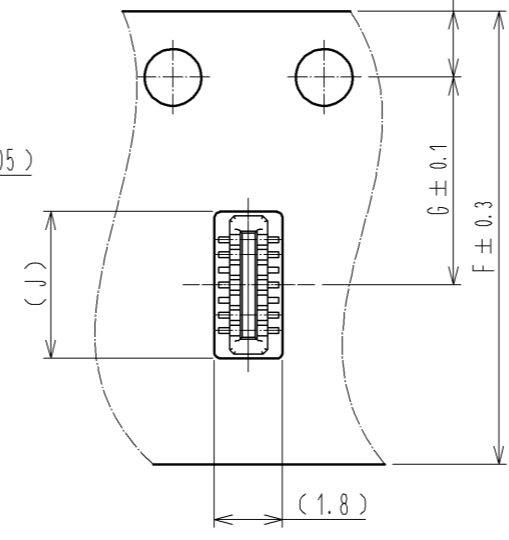

PART No.	F	G	H	J	K	L	M
BM14B(0.8)-10DP-0.4V(51)	12	5.5	—	3.88	13.5	17.5	—
BM14B(0.8)-12DP-0.4V(51)	12	5.5	—	4.28	13.5	17.5	—
BM14B(0.8)-20DP-0.4V(51)	16	7.5	2.77	5.88	17.5	21.5	—
BM14B(0.8)-22DP-0.4V(51)	16	7.5	3.17	6.28	17.5	21.5	—
BM14B(0.8)-24DP-0.4V(51)	16	7.5	3.57	6.68	17.5	21.5	—
BM14B(0.8)-30DP-0.4V(51)	24	11.5	4.77	7.88	25.5	29.5	—
BM14B(0.8)-34DP-0.4V(51)	24	11.5	5.57	8.68	25.5	29.5	—
BM14B(0.8)-40DP-0.4V(51)	24	11.5	6.77	9.88	25.5	29.5	—
BM14B(0.8)-50DP-0.4V(51)	24	11.5	8.77	11.88	25.5	29.5	—
BM14B(0.8)-60DP-0.4V(51)	24	11.5	10.77	13.88	25.5	29.5	—

- 7. PER REEL 8000 CONNECTORS.
- 8. THE DIMENSIONS IN PARENTHESES ARE FOR REFERENCE.
- 9. REFER TO JIS C 0806(PACKAGING OF COMPONENTS FOR AUTOMATIC HANDLING)
- 10. EMBOSSED CARRIER TAPE USED ON 10 TO 60 POSITIONS HAS THE SPROCKET HOLE ON ONE SIDE.
- 11. 10 POS AND 12POS POCKET SHAPE ARE AS SHOWN IN THE FIGURE.
- 12. AFTER PACKAGING, ROLL 2 METERS OF THE REINFORCEMENT COLLAR TO OUTER CIRCUMFERENCE OF TAPE AND REEL POCKET, AND TAPE DOWN AT THE END THE COLLAR.

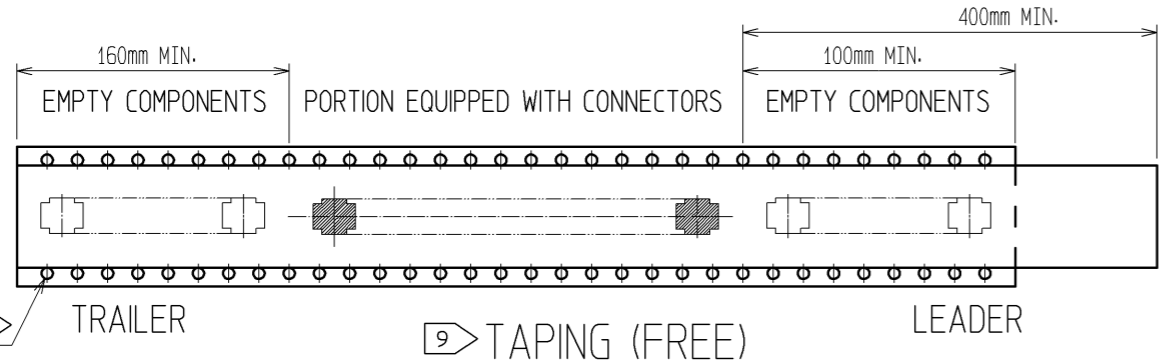

HRS	DRAWING NO.	EDC3-322328-04
	PART NO.	BM14B(0.8)-*DP-0.4V(51)
	CODE NO.	CL684
		3/3

Looking for pricing, stock, or lifecycle information?

Click below to explore more details on WIN SOURCE:

- ⊖ [View BM14B\(0.8\)-10DP-0.4V\(51\) on WIN SOURCE](#)
- ⊖ [Hirose Electric Co Ltd Information](#)

Optimize Your Supply Chain with WIN SOURCE Solutions

- ✓ Global Sourcing Solution
- ✓ Obsolete Management
- ✓ Cost Control Management
- ✓ Shortage Management
- ✓ Alternative Solution
- ✓ Excess Inventory Management