



**THE DATASHEET OF**  
**5033042610**



注記 NOTES

1. 使用材料 MATERIAL

ハウジング : 液晶ポリマー ( LCP ) UL94V-0 ( 黒 )  
 HOUSING: LIQUID CRYSTAL POLYMER UL94V-0 ( COLOR:BLACK )  
 ターミナル : 銅合金  
 TERMINAL : COPPER ALLOY

金具 : 銅合金  
 FITTING NAIL : COPPER ALLOY

5. テール平坦度は、 0.08 以下

テール及び金具の平坦度は、 0.1 以下  
 TAIL COPLANARITY TO BE 0.08 MAXIMUM.  
 TAIL AND FITTING NAIL COPLANARITY TO BE 0.1 MAXIMUM.  
 6. ELV and RoHS COMPLIANT.

2. メッキ仕様 PLATING

ターミナル TERMINAL

金メッキ  
 GOLD  
 下地メッキ : ニッケルメッキ  
 UNDER PLATING : NICKEL

※コンタクト部とテール部はニッケルメッキによって分断されている金メッキです。  
 DIVIDE INTO PARTS THE GOLD PLATING OF THE CONTACT AND THE TAIL PART BY THE NICKEL PLATING.

金具 FITTING NAIL

錫メッキ  
 Tin PLATING  
 下地メッキ : ニッケルメッキ  
 UNDER PLATING : NICKEL

△ ( 全極数 / 2 ) = 偶数の場合に適用。  
 APPLY FOR (CIRCUIT/2)=EVEN.

4. 嵌合相手 : 503308 シリーズ  
 MATE WITH : 503308 SERIES.

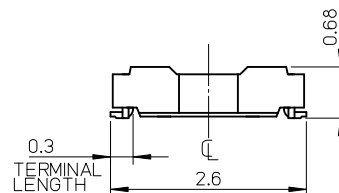
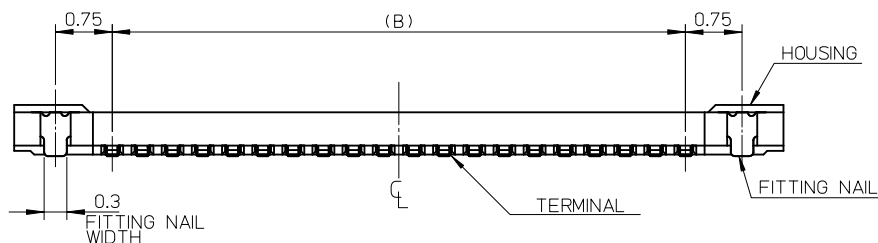
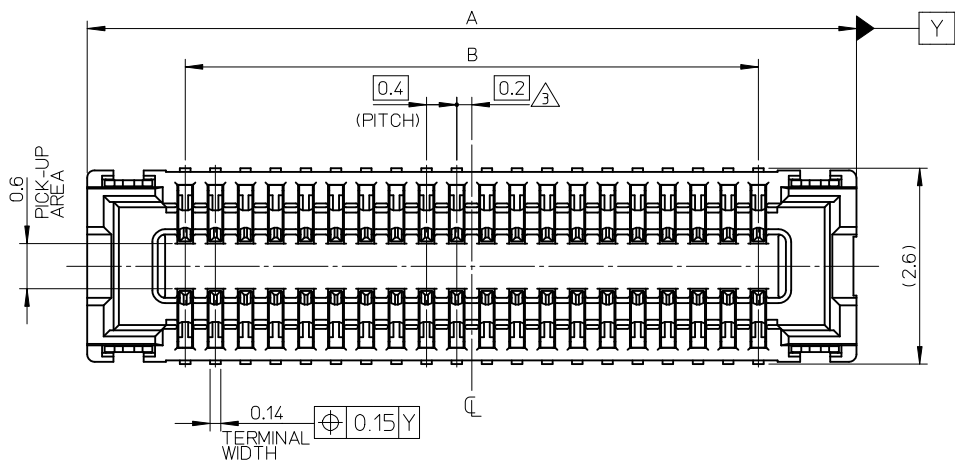

11.6	14.2	503304-6010	60
9.6	12.2	503304-5010	50
8.4	11.0	503304-4410	44
8.0	10.6	503304-4210	42
7.6	10.2	503304-4010	40
5.6	8.2	503304-3010	30
4.8	7.4	503304-2610	26
4.4	7.0	503304-2410	24
3.6	6.2	503304-2010	20
3.2	5.8	503304-1810	18
2.8	5.4	503304-1610	16
2.0	4.6	503304-1210	12
B	A	EMBOSSED PACKAGE	
		極数	CIRCUITS
		オーダー番号 ORDER No.	
CONNECTOR SERIES No. : 503304-**09			

REVISED EC NO: J2011-0495 DRWN: M. AKAHASHI 03/20/10/05/14 CHKD: 20/10/10/05 APPR: MSASAO 20/10/10/05	DESCRIPTION REV	GENERAL TOLERANCES (UNLESS SPECIFIED)		DIMENSION STYLE MM ONLY		SCALE 15:1	DESIGN UNITS METRIC	THIRD ANGLE PROJECTION	
		10 UNDER	± 0.2	DRAWN BY KSASAKI	DATE 2008/04/17	TITLE 0.4 B-TO-B CONN. HGT=0.7 W=2.6 REC. ASS'Y			
		10 OVER 30 UNDER	± 0.25	CHECKED BY THIRATA	DATE 2008/04/17	MOLEX INCORPORATED DOCUMENT NO. SD-503304-001 SHEET NO. 1 OF 2			
		30 OVER	± 0.3	APPROVED BY M. SASAO	DATE 2008/04/17				
		ANGULAR ± 1 °		DRAFT WHERE APPLICABLE MUST REMAIN WITHIN DIMENSIONS		MATERIAL NO. SEE CHART			
				SIZE A3	THIS DRAWING CONTAINS INFORMATION THAT IS PROPRIETARY TO MOLEX INCORPORATED AND SHOULD NOT BE USED WITHOUT WRITTEN PERMISSION				

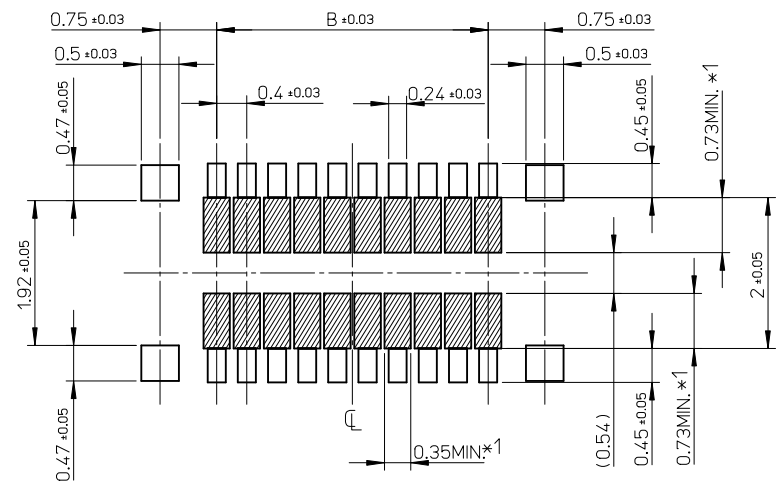

RECOMMENDED P.W. BOARD  
PATTERN LAYOUT

- \*1 パターン引き回し、および半田禁止エリア  
(当該箇所においては、これと接する回路以外の配線を禁止する。  
また、接する回路を配線する場合はレジストを施し、この部分に  
半田は無きこととする。)
- \*1 PROHIBITED AREA OF PATTERN WIRING AND SOLDER.  
(FOR EACH AREA, THE WIRING THAT TOUCHES ON THE SOLDER  
CAN BE ATTACHED, THEN COVERED WITH A FILM TO KEEP SOLDER OUT.)

REVISED IEC NO: J2011-0495 DRW:NTAKAHASHI03 2010/05/14 CHKD: 2010/10/05 APPR:MSASAO 2010/10/05	GENERAL TOLERANCES (UNLESS SPECIFIED)		DIMENSION STYLE MM ONLY	SCALE 15:1	DESIGN UNITS METRIC	THIRD ANGLE PROJECTION
	10 UNDER	±0.2	DRAWN BY KSASAKI	DATE 2008/04/17	TITLE 0.4 B-TO-B CONN. HGT=0.7 W=2.6 REC. ASS'Y	
	10 OVER 30 UNDER	±0.25	CHECKED BY THIRATA	DATE 2008/04/17		
	30 OVER	±0.3	APPROVED BY M. SASAO	DATE 2008/04/17	MOLEX INCORPORATED DOCUMENT NO. SD-503304-001 SHEET NO. 2 OF 2	
ANGULAR ±1 °		MATERIAL NO. SEE CHART				
DRAFT WHERE APPLICABLE MUST REMAIN WITHIN DIMENSIONS		THIS DRAWING CONTAINS INFORMATION THAT IS PROPRIETARY TO MOLEX INCORPORATED AND SHOULD NOT BE USED WITHOUT WRITTEN PERMISSION				

注記 NOTES

- 製品詳細寸法については製品単体図面を参照下さい。  
RE DETAILED DIMENSION, SEE PRODUCT DRAWING.
- 梱包数量：3000 個/リール  
NUMBER OF CONNECTORS : 3000PCS/REEL
- リードテープ長さ LEAD TAPE LENGTH

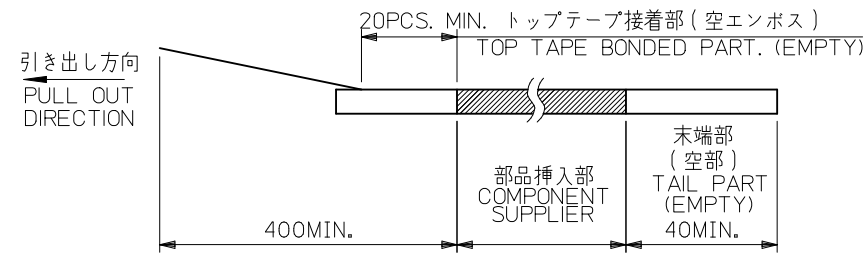
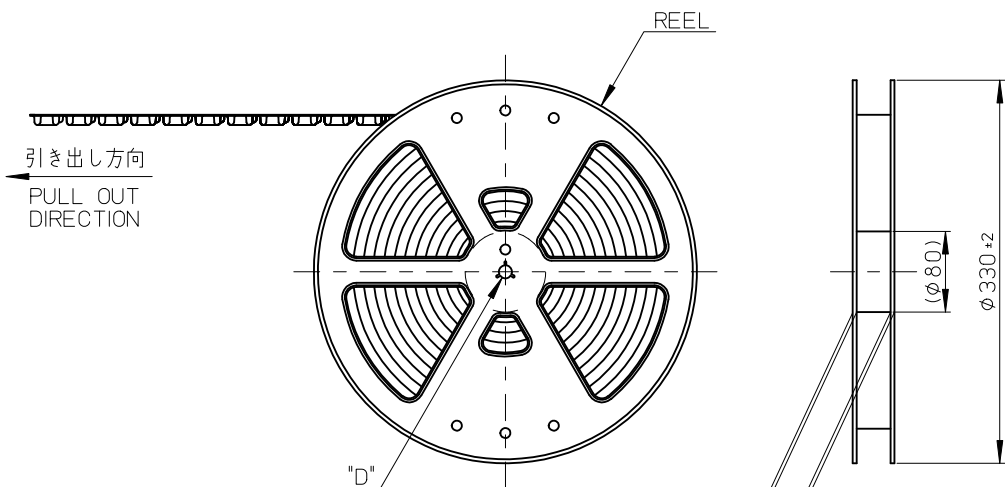

- トップテープの剥離強度：0.1N~1.3N(10gf~130gf)  
(剥離方向は下図参照)  
尚、本規格値は出荷時に適用。(但し、輸送時に剥離が発生しないこと。)  
PEELING OFF FORCE OF TOP TAPE : 0.1N~1.3N(10gf~130gf)  
(PEELING DIRECTION AS SHOWN IN FOLLOWING FIG.)  
THIS REQUIREMENT SHOULD BE APPLIED AT SHIPMENT.  
PEEL OFF SHOULD NOT BE ALLOWED , DURING TRANSPORTION.

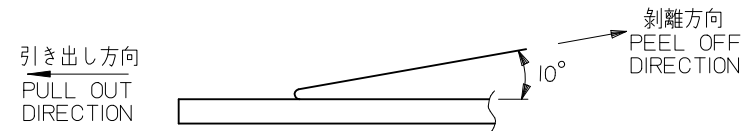

- 材料 MATERIAL  
キャリアテープ (CARRIER TAPE) : ポリスチレン (POLYSTYRENE)  
トップテープ (TOP TAPE) : PET , OTHER  
リール (REEL) : ポリスチレン (PS) <リサイクル材を含む>  
POLYSTYRENE (PS) <RECYCLE MATERIAL CONTAINED>
- ELV 及び RoHS適合品  
ELV AND RoHS COMPLIANT

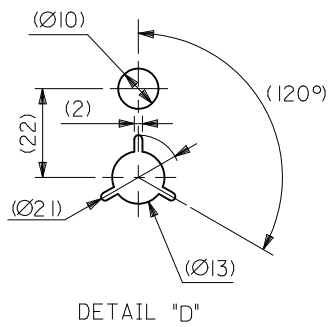

REVISED EC NO: J2011-0495 DRWN:KSASAKI CHKD: APPR:MSASAO	DESCRIPTION 2010/08/16 2010/10/05 2010/10/05	GENERAL TOLERANCES (UNLESS SPECIFIED)		DIMENSION STYLE MM ONLY		SCALE	DESIGN UNITS	MODEL NO.	503304-**10	
		10 UNDER	$\pm 0.2$	DRAWN BY KSASAKI		DATE 2008/12/12	TITLE	THIRD ANGLE PROJECTION		
		10 OVER 30 UNDER	$\pm 0.25$	CHECKED BY THIRATA		DATE 2008/12/12	0.4 B-TO-B CONN. HGT=0.7 REC ASSY EMBSTP PKG			
		30 OVER	$\pm 0.3$	APPROVED BY MSASAO		DATE 2008/12/12	MOLEX INCORPORATED			
ANGULAR $\pm 1^\circ$		DRAFT WHERE APPLICABLE MUST REMAIN WITHIN DIMENSIONS		MATERIAL NO. SEE CHART		DOCUMENT NO. SD-503304-002		SHEET NO. 1 OF 3		
THIS DRAWING CONTAINS INFORMATION THAT IS PROPRIETARY TO MOLEX INCORPORATED AND SHOULD NOT BE USED WITHOUT WRITTEN PERMISSION										

引き出し方向  
PULL OUT DIRECTION

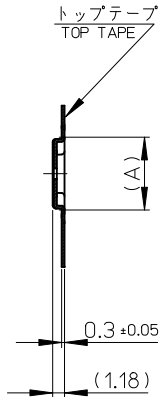

SECTION Y-Y

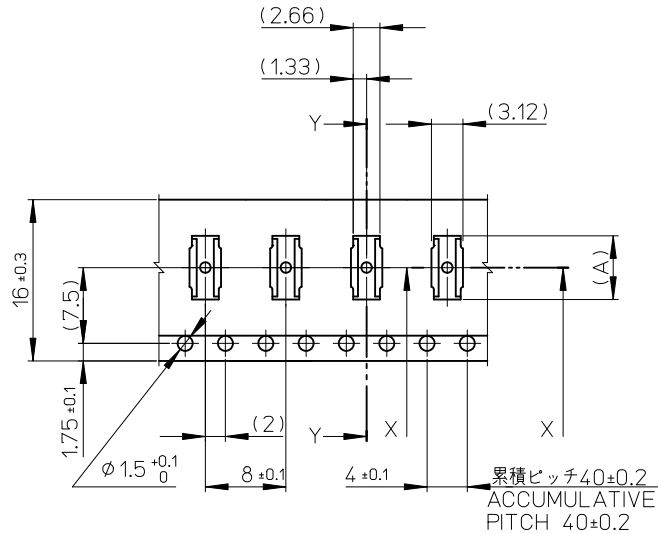

累積ピッチ 40±0.2  
ACCUMULATIVE PITCH 40±0.2

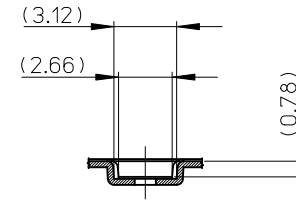

SECTION X-X

16mm 幅キャリアテープ  
16mm WIDTH CARRIER TAPE

16	21.4	17.4	7.52	503304-2610	26
			7.12	503304-2410	24
			6.32	503304-2010	20
			5.92	503304-1810	18
			5.52	503304-1610	16
			4.72	503304-1210	12
キャリアテープ幅 CARRIER TAPE WIDTH			C	B	(A)
			MATERIAL No.		CKT.
			MODEL No.		503304-**10

REVISED EC NO: J2011-0495 DRWN:KSASAKI CHKD: APPR:MSASAO 2010/08/16 2010/10/05 2010/10/05	DESCRIPTION REV	GENERAL TOLERANCES (UNLESS SPECIFIED)		DIMENSION STYLE MM ONLY		SCALE	DESIGN UNITS	TITLE 0.4 B-TO-B CONN. HGT=0.7 REC ASSY EMBSTP PKG
		10 UNDER	± 0.2	DRAWN BY DATE		MOLEX INCORPORATED DOCUMENT NO. SD-503304-002 SHEET NO. 2 OF 3		
		10 OVER 30 UNDER	± 0.25	CHECKED BY DATE				
		30 OVER	± 0.3	APPROVED BY DATE				
ANGULAR ± 1 °		MATERIAL NO.		SEE CHART				
DRAFT WHERE APPLICABLE MUST REMAIN WITHIN DIMENSIONS		SIZE A3		THIS DRAWING CONTAINS INFORMATION THAT IS PROPRIETARY TO MOLEX INCORPORATED AND SHOULD NOT BE USED WITHOUT WRITTEN PERMISSION				

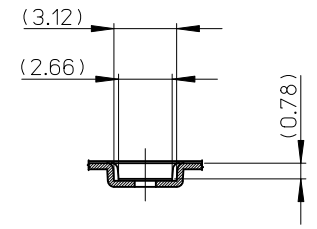
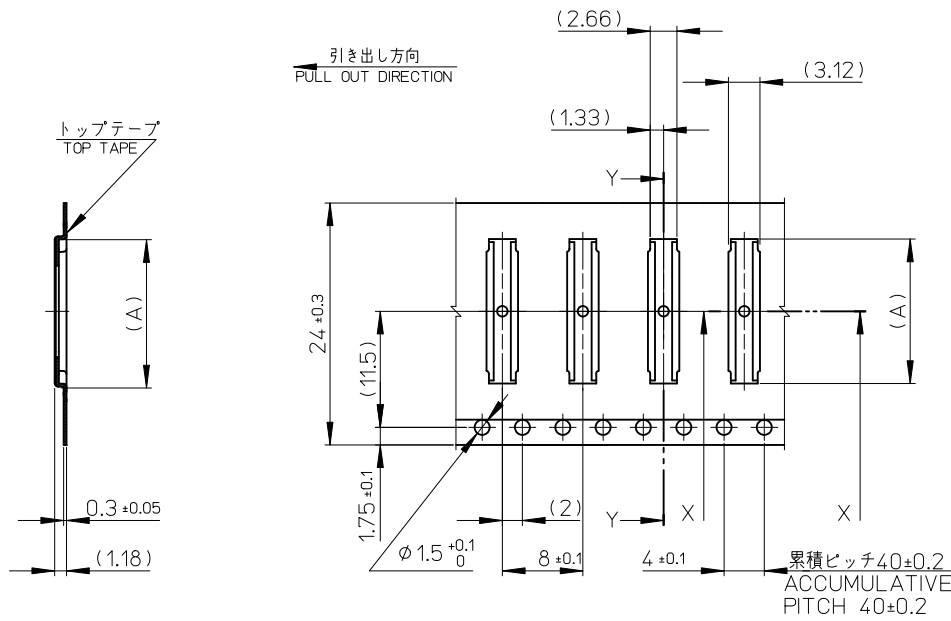

SECTION X-X

SECTION Y-Y

24mm 幅キャリアテープ  
24mm WIDTH CARRIER TAPE

24	29.4	25.4	14.32	503304-6010	60
			12.32	503304-5010	50
			11.12	503304-4410	44
			10.72	503304-4210	42
			10.32	503304-4010	40
			8.32	503304-3010	30
キャリアテープ幅 CARRIER TAPE WIDTH			C	B	(A)
			MATERIAL No.		CKT.
			MODEL No.		503304-**10

REVISED EC NO: J2011-0495 DRWN:KSASAKI CHKD: APPR:MSASAO 2010/08/16 2010/10/05 2010/10/05	DESCRIPTION REV	GENERAL TOLERANCES (UNLESS SPECIFIED)		DIMENSION STYLE MM ONLY		SCALE	DESIGN UNITS	THIRD ANGLE PROJECTION		
		10 UNDER	±0.2	DRAWN BY	DATE	TITLE	0.4 B-TO-B CONN. HGT=0.7 REC ASSY EMBSTP PKG			
		10 OVER 30 UNDER	±0.25	CHECKED BY	DATE	MOLEX INCORPORATED				
		30 OVER	±0.3	APPROVED BY	DATE	SEE CHART		DOCUMENT NO.	SHEET NO.	
ANGULAR ±1 ° DRAFT WHERE APPLICABLE MUST REMAIN WITHIN DIMENSIONS		MATERIAL NO. A3		THIS DRAWING CONTAINS INFORMATION THAT IS PROPRIETARY TO MOLEX INCORPORATED AND SHOULD NOT BE USED WITHOUT WRITTEN PERMISSION		SD-503304-002		3 OF 3		

## Looking for pricing, stock, or lifecycle information?

Click below to explore more details on WIN SOURCE:

 [View 5033042610 on WIN SOURCE](#)

 [Molex, LLC Information](#)

## Optimize Your Supply Chain with WIN SOURCE Solutions

-  Global Sourcing Solution
-  Obsolete Management
-  Cost Control Management
-  Shortage Management
-  Alternative Solution
-  Excess Inventory Management