



**THE DATASHEET OF
BGS15MA12E6327XTSA1**



BGS15MA12

SP5T Rx Diversity Switch

Data Sheet

Revision 3.1 - 2016-05-11

Edition 2016-05-11

**Published by Infineon Technologies AG
81726 Munich, Germany**

**©2016 Infineon Technologies AG
All Rights Reserved.**

LEGAL DISCLAIMER

The information given in this document shall in no event be regarded as a guarantee of conditions or characteristics. With respect to any examples or hints given herein, any typical values stated herein and/or any information regarding the application of the device, Infineon Technologies hereby disclaims any and all warranties and liabilities of any kind, including without limitation, warranties of non-infringement of intellectual property rights of any third party.

Information

For further information on technology, delivery terms and conditions and prices, please contact the nearest Infineon Technologies Office (www.infineon.com).

Warnings

Due to technical requirements, components may contain dangerous substances. For information on the types in question, please contact the nearest Infineon Technologies Office. Infineon Technologies components may be used in life-support devices or systems only with the express written approval of Infineon Technologies, if a failure of such components can reasonably be expected to cause the failure of that life-support device or system or to affect the safety or effectiveness of that device or system. Life support devices or systems are intended to be implanted in the human body or to support and/or maintain and sustain and/or protect human life. If they fail, it is reasonable to assume that the health of the user or other persons may be endangered.

Revision History

Document No.: BGS15MA12__v3.1.pdf

Revision History: Rev. v3.1

Previous Version: Revision v3.0 - 2015-07-24

Page	Subjects (major changes since last revision)
20	Carrier Tape drawing updated (Fig. 12)

Trademarks of Infineon Technologies AG

μ HVICTM, μ IPMTM, μ PFCTM, AU-ConvertIRTM, AURIXTM, C166TM, CanPAKTM, CIPOSTM, CIPURSETM, CoolDPTM, CoolGaNTM, COOLiRTM, CoolMOSTM, CoolSETTM, CoolSiCTM, DAVETM, DI-POLTM, DirectFETTM, DrBladeTM, EasyPIMTM, EconoBRIDGETM, EconoDUALTM, EconoPACKTM, EconoPIMTM, EiceDRIVERTM, eupecTM, FCOSTM, GaNpowIRTM, HEXFETTM, HITFETTM, HybridPACKTM, iMOTIONTM, IRAMTM, ISOFACETM, IsoPACKTM, LEDrivIRTM, LITIXTM, MIPAQTM, ModSTACKTM, my-dTM, NovalithICTM, OPTIGATM, OptiMOSTM, ORIGATM, PowIRaudioTM, PowIRStageTM, PrimePACKTM, PrimeSTACKTM, PROFETTM, PRO-SILTM, RASICTM, REAL3TM, SmartLEWISTM, SOLID FLASHTM, SPOCTM, StrongIRFETTM, SupIRBuckTM, TEMPFETTM, TRENCHSTOPTM, TriCoreTM, UHVICTM, XHPTM, XMCTM.

Other Trademarks

All referenced product or service names and trademarks are the property of their respective owners.

Trademarks updated November 2015

Contents

1	Features	5
2	Product Description	5
3	Maximum Ratings	6
4	Operation Ranges	8
5	RF Characteristics	9
6	MIPI RFFE Specification	11
7	Application Information	17
8	Package Information	19

List of Figures

1	BGS15MA12 Block diagram	6
2	MIPI to RF Time	10
3	Power-Up Settling Time Definition: a) when the device is already in Active Mode. b) when changing from Low Power Mode to Active Mode. After Power-Up of VIO the device is set to Low Power Mode. An additional MIPI instruction is necessary to set the switch to Active Mode. This case is covered by b) .	10
4	Received clock signal constraints	12
5	Bus active data receiver timing requirements	13
6	Bus park cycle timing	13
7	Bus active data transmission timing specification	14
8	Requirements for VIO-initiated reset	14
9	BGS15MA12 Pin Configuration (top view)	17
10	BGS15MA12 Application Schematic	18
11	ATSLP-12-4 Package Outline (top, side and bottom views)	19
12	Marking Specification (top view)	19
13	Footprint Recommendation	20
14	ATSLP-12-4 Carrier Tape	20

List of Tables

1	Ordering Information	5
2	Maximum Ratings, Table I	6
3	Maximum Ratings, Table II	7
4	Operation Ranges	8
5	RF Input Power	8
6	RF Characteristics	9
7	MIPI Features	11
8	Startup Behavior	11
9	MIPI RFFE operating timing	12
10	Register Mapping	15
11	Truth Table, Register_0	16
12	Pin Definition and Function	17
13	Bill of Materials	18

BGS15MA12 SP5T Rx Diversity Switch

1 Features

- Low insertion loss
- Low harmonic generation
- High port-to-port-isolation
- Suitable for LTE / WCDMA Rx Applications
- 0.1 to 2.9 GHz coverage
- No decoupling capacitors required if no DC applied on RF lines
- On chip control logic including ESD protection
- Integrated MIPI RFFE interface operating in 1.1 to 1.95 V voltage range
- Software programmable MIPI RFFE USID
- Direct to battery supply
- Small form factor 1.1 mm x 1.9 mm
- No power supply blocking required
- High EMI robustness
- RoHS and WEEE compliant package

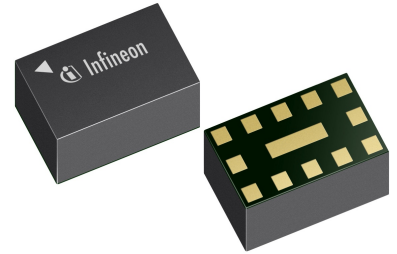

2 Product Description

The BGS15MA12 RF MOS switch is specifically designed for LTE and WCDMA diversity applications. This SP5T offers low insertion loss and low harmonic generation in termination mode.

The switch is controlled via a MIPI RFFE controller. The on-chip controller allows power-supply voltages from 1.1 to 1.95 V. The switch features direct-connect-to-battery functionality and DC-free RF ports. Unlike GaAs technology, external DC blocking capacitors at the RF Ports are only required if DC voltage is applied externally. The BGS15MA12 RF Switch is manufactured in Infineon's patented MOS technology, offering the performance of GaAs with the economy and integration of conventional CMOS including the inherent higher ESD robustness. The device has a very small size of only 1.1 x 1.9 mm² and a maximum height of 0.65 mm.

Table 1: Ordering Information

Type	Package	Marking	Chip
BGS15MA12	ATSLP-12-4	S4	m4829

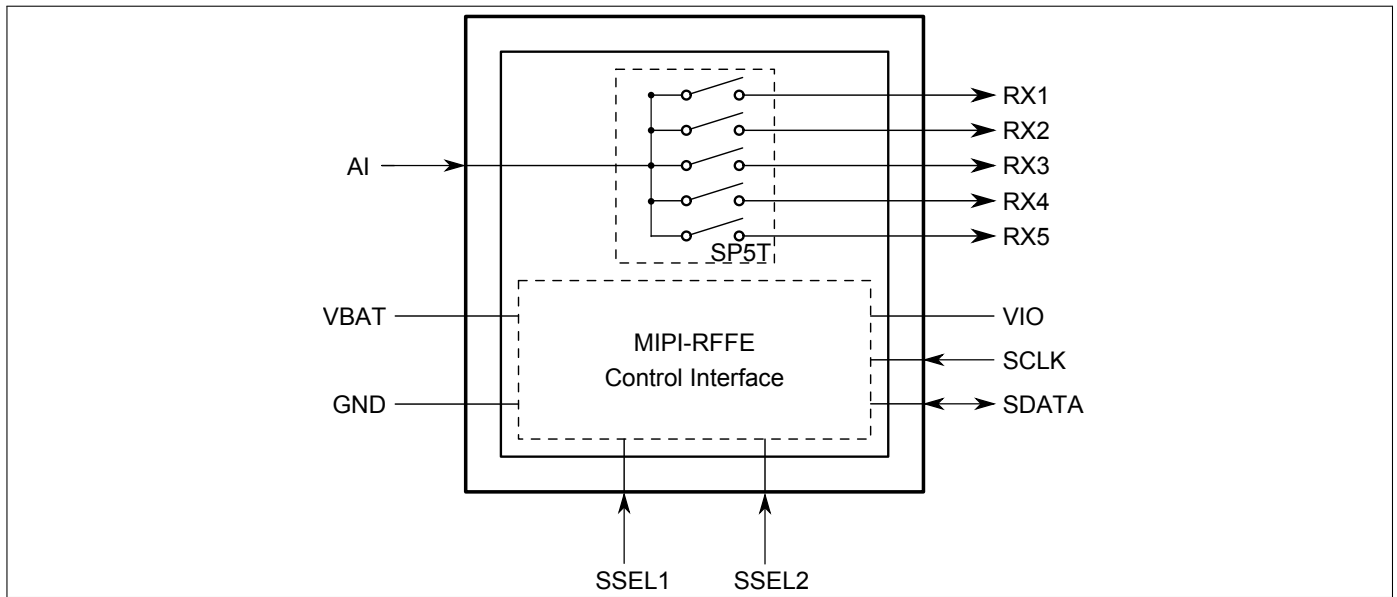
Figure 1: BGS15MA12 Block diagram

3 Maximum Ratings

Table 2: Maximum Ratings, Table I at $T_A = 25\text{ }^\circ\text{C}$, unless otherwise specified

Parameter	Symbol	Values			Unit	Note / Test Condition
		Min.	Typ.	Max.		
Frequency Range	f	0.1	–	–	GHz	¹⁾
Supply voltage	V_{BAT}	-0.5	–	6.0	V	–
Storage temperature range	T_{STG}	-55	–	150	$^\circ\text{C}$	–
Junction temperature	T_j	–	–	125	$^\circ\text{C}$	–
RF input power at all RX ports	P_{RF_RX}	–	–	27	dBm	CW
ESD capability, CDM ²⁾	V_{ESD_CDM}	-1	–	+1	V	All pins
ESD capability, HBM ³⁾	V_{ESD_HBM}	-1	–	+1	kV	Digital, digital versus RF
		-1	–	+1	kV	RF

¹⁾There is also a DC connection between switched paths. The DC voltage at RF ports V_{RFDC} has to be 0V.

²⁾Field-Induced Charged-Device Model JESD22-C101. Simulates charging/discharging events that occur in production equipment and processes. Potential for CDM ESD events occurs whenever there is metal-to-metal contact in manufacturing.

³⁾Human Body Model ANSI/ESDA/JEDEC JS-001-2012 ($R=1.5\text{ k}\Omega$, $C=100\text{ pF}$).

⁴⁾IEC 61000-4-2 ($R=330\text{ }\Omega$, $C=150\text{ pF}$), contact discharge.

Table 3: Maximum Ratings, Table II at $T_A = 25\text{ °C}$, unless otherwise specified

Parameter	Symbol	Values			Unit	Note / Test Condition
		Min.	Typ.	Max.		
Maximum DC-voltage on RF-Ports and RF-Ground	V_{RFDC}	0	–	0	V	No DC voltages allowed on RF-Ports
RF FE Supply Voltage	V_{IO}	-0.5	–	3	V	–
RF FE Control Voltage Levels at SCLK, SDATA, SSEL1, SSEL2	V	-0.7	–	$V_{IO}+0.7$ (max. 3)	V	–

4 Operation Ranges

Table 4: Operation Ranges

Parameter	Symbol	Values			Unit	Note / Test Condition
		Min.	Typ.	Max.		
Supply voltage	V_{BAT}	2.2	–	5.5	V	–
Supply current ³⁾	I_{BAT}	–	80	200	μA	–
Supply current in standby mode ³⁾	I_{BAT_SB}	–	0.5	1	μA	V_{IO} =low or MIPI low-power mode
RFFE supply voltage	V_{IO}	1.1	1.8	1.95	V	–
RFFE input high voltage ¹⁾	V_{IH}	$0.7 \cdot V_{IO}$	–	V_{IO}	V	–
RFFE input low voltage ¹⁾	V_{IL}	0	–	$0.3 \cdot V_{IO}$	V	–
RFFE output high voltage ²⁾	V_{OH}	$0.8 \cdot V_{IO}$	–	V_{IO}	V	–
RFFE output low voltage ²⁾	V_{OL}	0	–	$0.2 \cdot V_{IO}$	V	–
RFFE control input capacitance	C_{Ctrl}	–	–	2	pF	–
RFFE supply current	I_{VIO}	–	15	–	μA	Idle State
Ambient temperature	T_A	-30	25	85	$^{\circ}C$	–

¹⁾SCLK, SDATA, SSEL1 and SSEL2

²⁾SDATA

³⁾ $T_A = -30^{\circ}C - 85^{\circ}C$, $V_{BAT} = 2.2 - 5.5 V$
Table 5: RF Input Power

Parameter	Symbol	Values			Unit	Note / Test Condition
		Min.	Typ.	Max.		
RX ports (50 Ω)	P_{RF_RX}	–	–	24	dBm	–

5 RF Characteristics

Table 6: RF Characteristics at $T_A = -30\text{ }^{\circ}\text{C}$ – $85\text{ }^{\circ}\text{C}$, $P_{IN} = 0\text{ dBm}$, Supply Voltage $V_{BAT} = 2.2\text{ V}$ – 5.5 V , unless otherwise specified

Parameter	Symbol	Values			Unit	Note / Test Condition
		Min.	Typ.	Max.		
Insertion Loss¹⁾						
All RX Ports	IL	0.2	0.28	0.35	dB	700–1000 MHz
		0.25	0.35	0.5	dB	1700–2200 MHz
		0.3	0.42	0.6	dB	2300–2700 MHz
Return Loss¹⁾						
All RX Ports	RL	20	30	–	dB	700–1000 MHz
		18	28	–	dB	1700–2200 MHz
		12	22	–	dB	2300–2700 MHz
Isolation all RX Ports	ISO	24	34	–	dB	700–1000 MHz
		17	27	–	dB	1700–2200 MHz
		15	25	–	dB	2300–2700 MHz
Isolation RX Ports to AI	ISO	26	36	–	dB	700–1000 MHz
		21	31	–	dB	1700–2200 MHz
		18	28	–	dB	2300–2700 MHz
P1 dB Compression Point, Extrapolated						
All RX Ports	P_{1dB}	>30	–	–	dBm	
Harmonic Generation up to 12.75 GHz						
All RX Ports	P_{Harm}	–	-95	-75	dBc	20 dBm, 50 Ω , CW mode
Intermodulation Distortion in Rx Band²⁾ ($T_A = 25\text{ }^{\circ}\text{C}$, $V_{BAT} = 2.6\text{ V}$)						
IMD2, low	$IMD2_{low}$	–	-115	-105	dBm	Tx = 10 dBm, Interferer = -15 dBm, 50 Ω
IMD3	IMD3	–	-125	-110	dBm	
IMD2, high	$IMD2_{high}$	–	-120	-110	dBm	
Switching Time						
RF Rise Time RX Port On/Off	$t_{on/off}$	0.5	1	5	μs	90% OFF to 90% ON; 90% ON to 90% OFF
MIPI to RF Time	t_{INT}	0.5	1.5	5	μs	50% last SCLK falling flank to 90% ON, Fig. 2
Power Up Settling Time	t_{PUS}	–	10	25	μs	After power down mode, Fig. 3

¹⁾On application board with a RF low-Q two element matching network at the antenna port

²⁾On application board with shunt inductor, Min/Max-values measured with phase shifter.

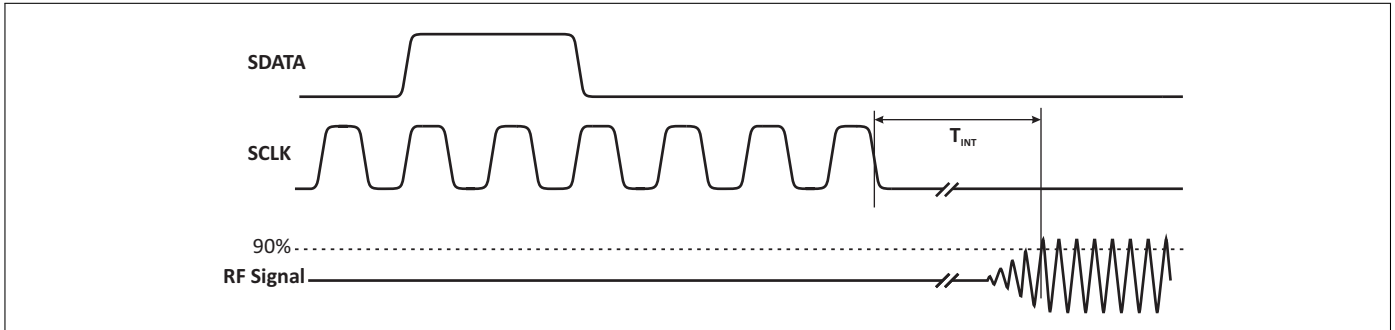

Figure 2: MIPI to RF Time

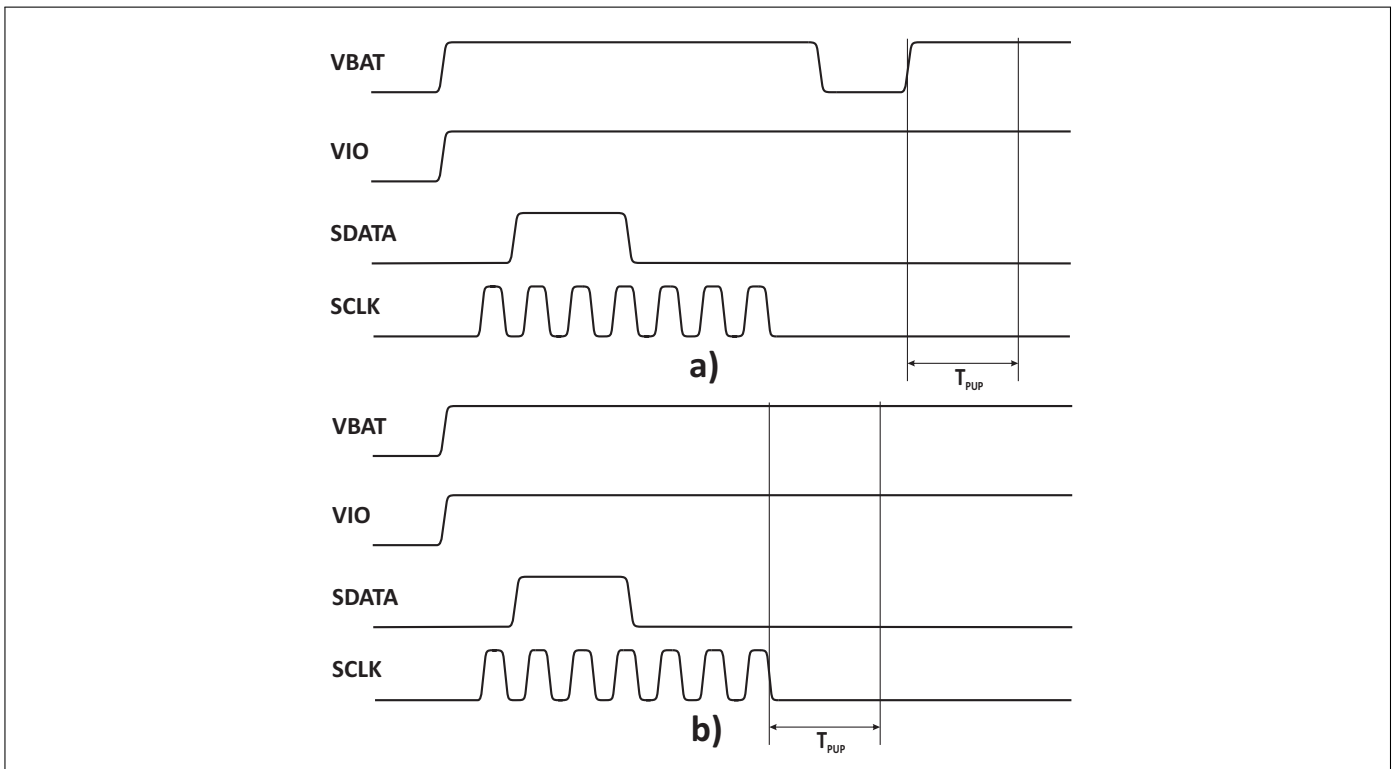

Figure 3: Power-Up Settling Time Definition: **a)** when the device is already in Active Mode. **b)** when changing from Low Power Mode to Active Mode. After Power-Up of VIO the device is set to Low Power Mode. An additional MIPI instruction is necessary to set the switch to Active Mode. This case is covered by **b)**.

6 MIPI RFFE Specification

All sequences are implemented according to the 'MIPI Alliance Specification for RF Front-End Control Interface' document version 1.10 - 26. July 2011.

Table 7: MIPI Features

Feature	Supported	Comment
Register write command sequence	Yes	
Register read command sequence	Yes	
Extended register write command sequence	No	Up to 4 Bytes
Extended register read command sequence	No	Up to 4 Bytes
Register 0 write command sequence	Yes	
Trigger function	Yes	Trigger assignment to each control register is supported
Programmable USID	Yes	3 register command sequence and extended register command sequence
Status Register	Yes	Register for debugging
Reset	Yes	By VIO, Power Mode and RFFE_STATUS
Group SID	Yes	
SSEL1 and SSEL2 pins	Yes	External pins for changing USID: SSEL1=0 & SSEL2=0 → 1000, SSEL1=0 & SSEL2=1 → 1001, SSEL1=1 & SSEL2=0 → 1010, SSEL1=1 & SSEL2=1 → 1011
Full speed write	Yes	
Half speed read	Yes	
Full speed read	Yes	

Table 8: Startup Behavior

Feature	State	Comment
Power status	LOW POWER	The chip is in low power mode after startup
Trigger function	ENABLED	Trigger function is enabled after startup. Trigger function can be disabled via PM_TRIG register.

Table 9: MIPI RFFE Operating Timing

Parameter	Symbol	Values			Unit	Note / Test Condition
		Min.	Typ.	Max.		
SCLK Frequency	FSCLK	0.032	–	26	MHz	Full speed
		0.032	–	13	MHz	Half speed
SCLK Period	TSCLK	0.038	–	32	μ s	Full speed
		0.077	–	32	μ s	Half speed
SCLK Low Period	TSCLKIL	11.25	–	–	ns	Full speed, see Fig. 4
		24	–	–	ns	Half speed, see Fig. 4
SCLK High Period	TSCLKIH	11.25	–	–	ns	Full speed, see Fig. 4
		24	–	–	ns	Half speed, see Fig. 4
SDATA Setup Time	TS	1	–	–	ns	Full speed, see Fig. 5
		2	–	–	ns	Half speed, see Fig. 5
SDATA Hold Time	TH	5	–	–	ns	Full speed, see Fig. 5
		5	–	–	ns	Half speed, see Fig. 5
SDATA Release Time	TSDATAZ	–	–	10	ns	Full speed, see Fig. 6
		–	–	18	ns	Half speed, see Fig. 6
Time for Data Output	TD	–	–	10.25	ns	Full speed, see Fig. 7
		–	–	22	ns	Half speed, see Fig. 7
SDATA Rise/Fall Time	TSDATAOTR	2.1	–	6.5	ns	Full speed, see Fig. 7
		2.1	–	10	ns	Half speed, see Fig. 7
VIO Rise Time	TVIO-R	10	–	450	μ s	See Fig. 8
VIO Reset Time	TVIO-RST	10	–	–	μ s	See Fig. 8
Reset Delay Time	TSIGOL	0.12	–	–	μ s	See Fig. 8

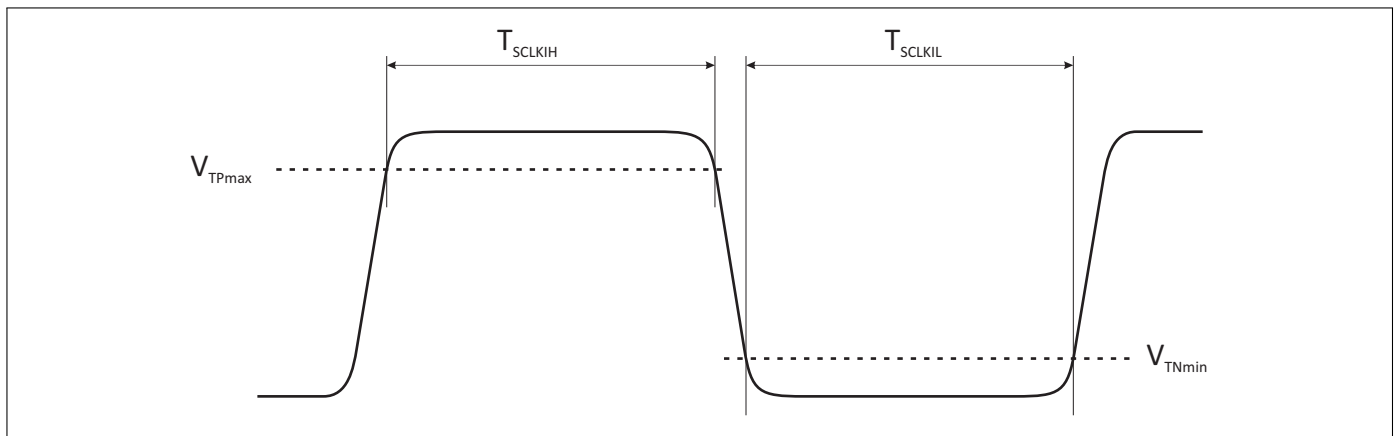
Figure 4: Received clock signal constraints

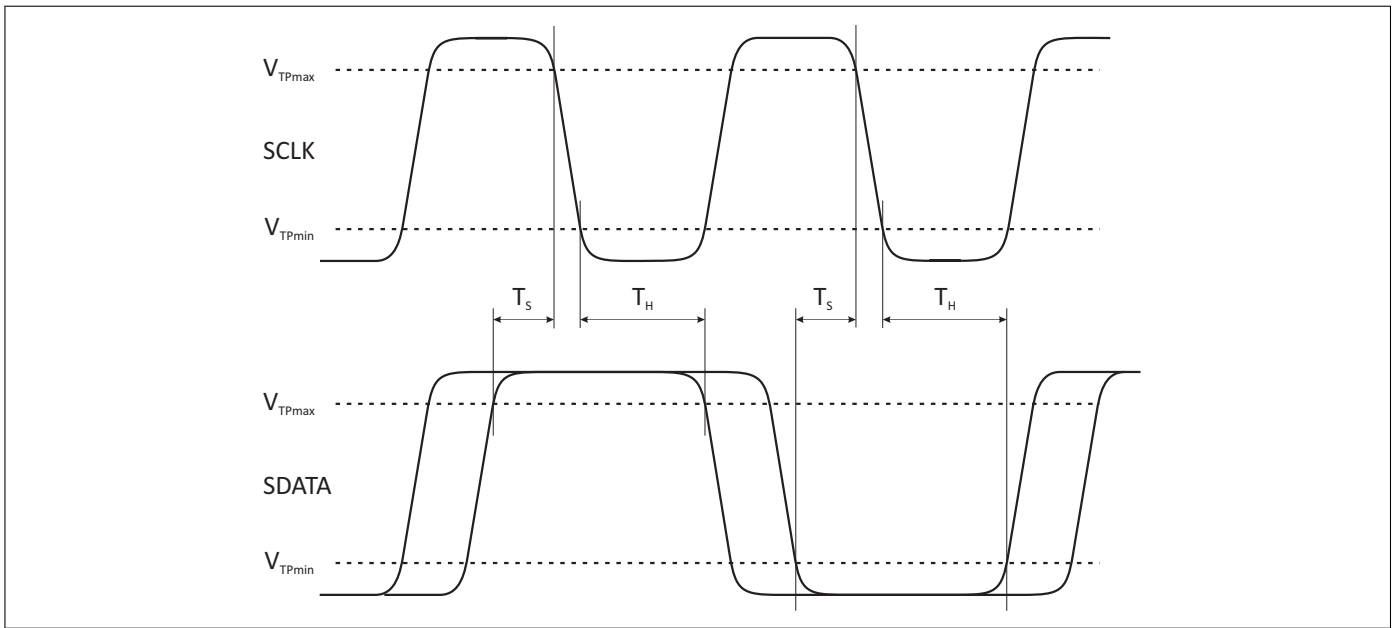

Figure 5: Bus active data receiver timing requirements

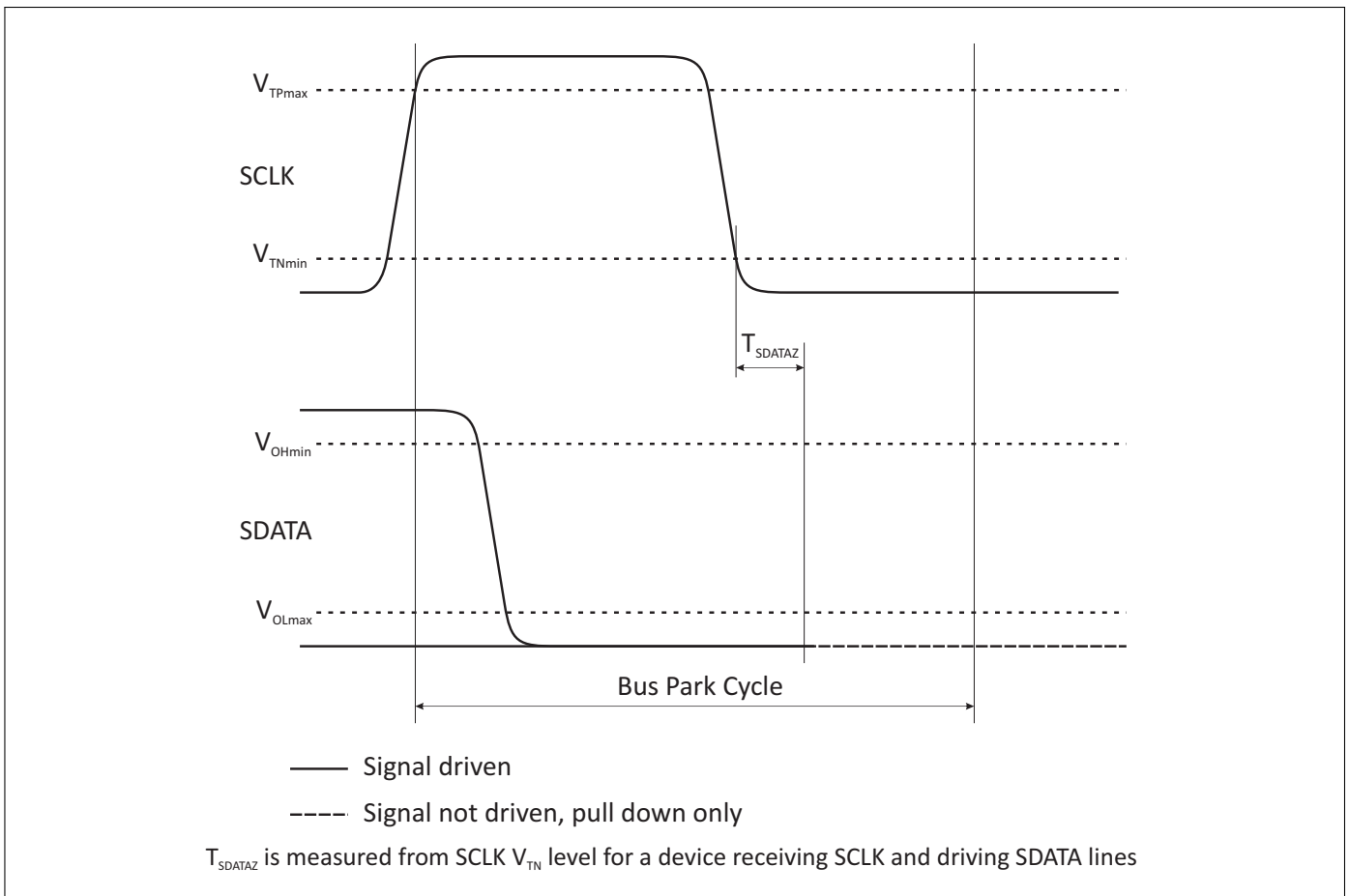

Figure 6: Bus park cycle timing

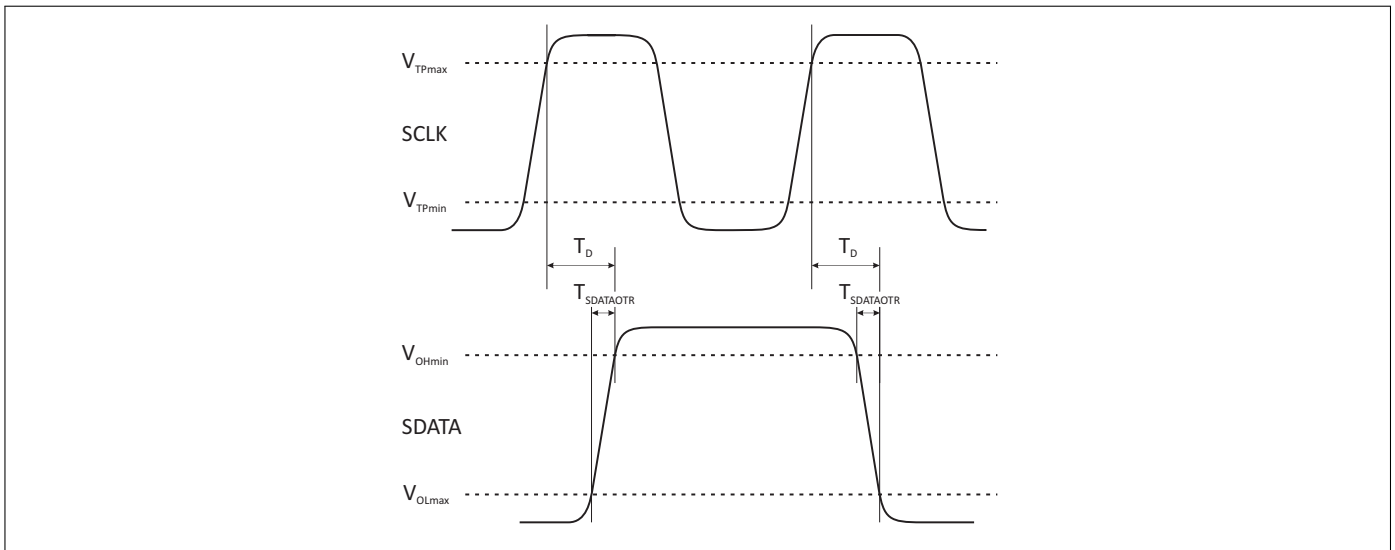

Figure 7: Bus active data transmission timing specification

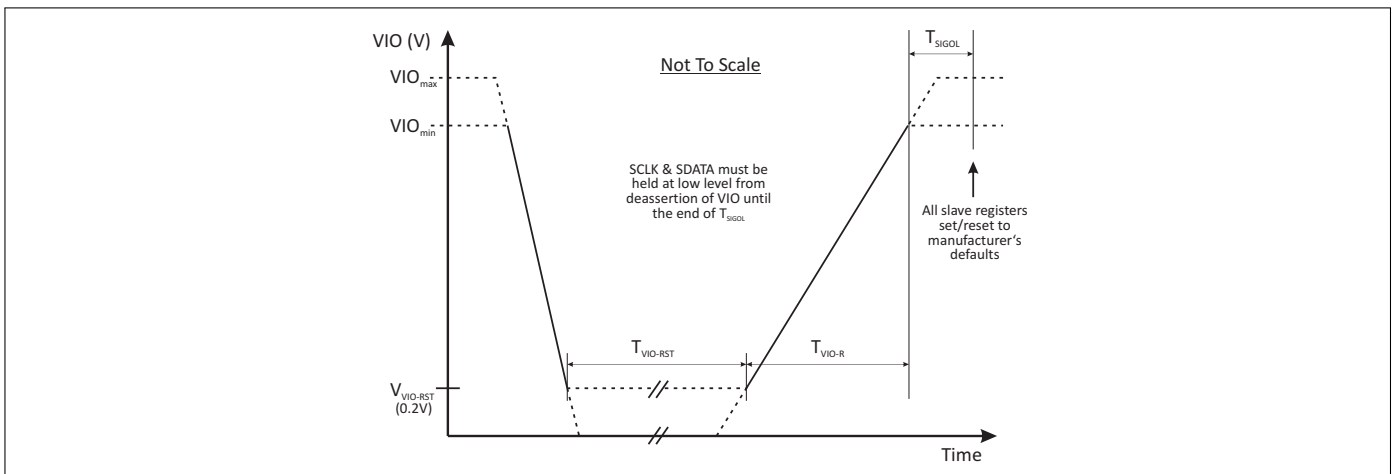

Figure 8: Requirements for VIO-initiated reset

Table 10: Register Mapping

Register Address	Register Name	Data Bits	Function	Description	Default	Broadcast_ID Support	Trigger Support	R/W	
0x0000	REGISTER_0	7:0	MODE_CTRL	Switch control	00000000	No	Yes	R/W	
0x001D	PRODUCT_ID	7:0	PRODUCT_ID	This is a read-only register. However, during the programming of the USID a write command sequence is performed on this register, even though the write does not change its value.	11010000	No	No	R	
0x001E	MANUFACTURER_ID	7:0	MANUFACTURER_ID [7:0]	This is a read-only register. However, during the programming of the USID, a write command sequence is performed on this register, even though the write does not change its value.	00011010	No	No	R	
0x001C	PM_TRIG	7:6	PWR_MODE	00: Normal operation 01: Default settings (STARTUP) 10: Low power (LOW POWER) 11: Reserved	10	Yes	No	R/W	
		5	TRIGGER_MASK_2	If this bit is set, trigger 2 is disabled. When all triggers disabled, if writing to a register that is associated to trigger 2, the data goes directly to the destination register.	0	No	No		
		4	TRIGGER_MASK_1	If this bit is set, trigger 1 is disabled. When all triggers disabled, if writing to a register that is associated to trigger 1, the data goes directly to the destination register.	0	No	No		
		3	TRIGGER_MASK_0	If this bit is set, trigger 0 is disabled. When all triggers disabled, if writing to a register that is associated to trigger 0, the data goes directly to the destination register.	0	No	No		
		2	TRIGGER_2	A write of a one to this bit loads trigger 2's registers.	0	Yes	No		
		1	TRIGGER_1	A write of a one to this bit loads trigger 1's registers.	0	Yes	No		R/W
		0	TRIGGER_0	A write of a one to this bit loads trigger 0's registers.	0	Yes	No		R/W
		0x001F	MAN_USID	7:6	SPARE	These are read-only bits that are reserved and yield a value of 0b00 at readback.	00	No	No
5:4	MANUFACTURER_ID [9:8]			These bits are read-only. However, during the programming of the USID, a write command sequence is performed on this register even though the write does not change its value.	01				
3:0	USID			Programmable USID. Performing a write to this register using the described programming sequences will program the USID in devices supporting this feature. These bits store the USID of the device.	USID_Sel12 =00 → 1000, USID_Sel12 =01 → 1001, USID_Sel12 =10 → 1010, USID_Sel12 =11 → 1011				

Continued on next page

Table 10: Register Mapping – Continued from previous page

Register Address	Register Name	Data Bits	Function	Description	Default	Broadcast_ID Support	Trigger Support	R/W
0x001A	RFFE_STATUS	7	SOFTWARE RESET	0: Normal operation 1: Software reset	0	No	No	R/W
		6	COMMAND_FRAME_PARITY_ERR	Command sequence received with parity error - discard command.	0	No	No	R
		5	COMMAND_LENGTH_ERR	Command length error	0			
		4	ADDRESS_FRAME_PARITY_ERR	Address frame parity error = 1	0			
		3	DATA_FRAME_PARITY_ERR	Data frame with parity error	0			
		2	READ_UNUSED_REG	Read command to an invalid address	0			
		1	WRITE_UNUSED_REG	Write command to an invalid address	0			
		0	BID_GID_ERR	Read command with a BROADCAST_ID or GROUP_SID	0			
0x001B	GROUP_SID	7:4	RESERVED		0			
		3:0	GROUP_SID	Group slave ID	0			

Table 11: Modes of Operation (Truth Table, Register_0)

State	Mode	REGISTER_0 Bits							
		D7	D6	D5	D4	D3	D2	D1	D0
1	Isolation	x	x	x	0	0	0	0	0
2	RX1-AI	x	x	x	0	0	0	0	1
3	RX2-AI	x	x	x	0	0	0	1	0
4	RX3-AI	x	x	x	0	1	0	0	0
5	RX4-AI	x	x	x	0	0	1	0	0
6	RX5-AI	x	x	x	1	0	0	0	0
7	RX1&RX2-AI	x	x	x	0	0	0	1	1
8	RX2&RX3-AI	x	x	x	0	1	0	1	0
9	RX3&RX4-AI	x	x	x	0	1	1	0	0
10	RX4&RX5-AI	x	x	x	1	0	1	0	0
11	RX1&RX3-AI	x	x	x	0	1	0	0	1
12	RX2&RX4-AI	x	x	x	0	0	1	1	0
13	RX3&RX5-AI	x	x	x	1	1	0	0	0
14	RX1&RX4-AI	x	x	x	0	0	1	0	1
15	RX2&RX5-AI	x	x	x	1	0	0	1	0
16	RX1&RX5-AI	x	x	x	1	0	0	0	1

7 Application Information

Pin Configuration and Function

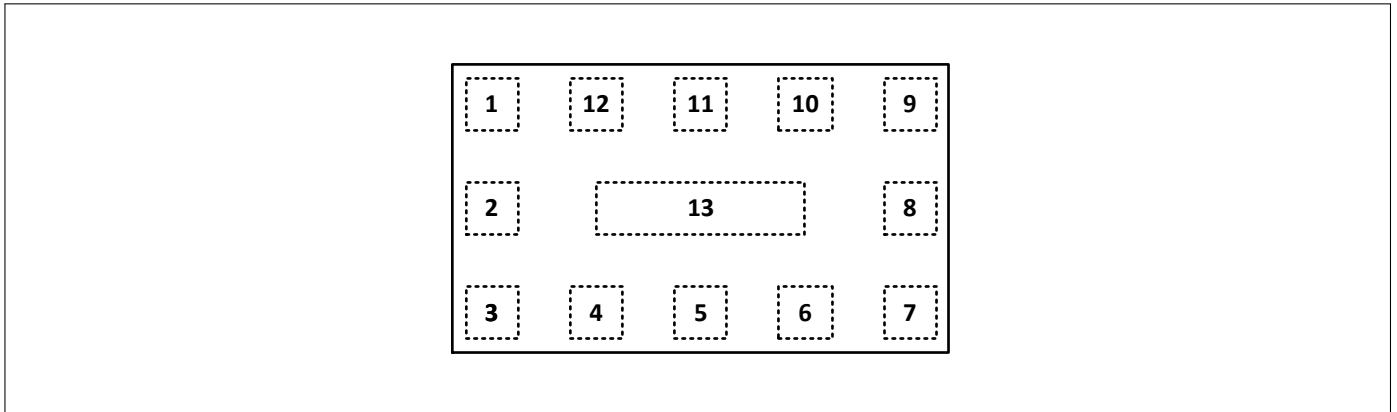

Figure 9: BGS15MA12 Pin Configuration (top view)

Table 12: Pin Definition and Function

Pin No.	Name	Function
1	SLK	MIPI RFFE Clock (Input)
2	VIO	MIPI RFFE Power Supply
3	RX5	RF-Port RX No. 5
4	RX4	RF-Port RX No. 4
5	RX3	RF-Port RX No. 3
6	RX2	RF-Port RX No. 2
7	RX1	RF-Port RX No. 1
8	SSEL1	MIPI SEL Port No. 1 (Input)
9	SSEL2	MIPI SEL Port No. 2 (Input)
10	AI	RF-Input Port
11	VBAT	Power Supply
12	SDATA	MIPI RFFE Data (Input / Output)
13	GND	Ground

Application Board Configuration

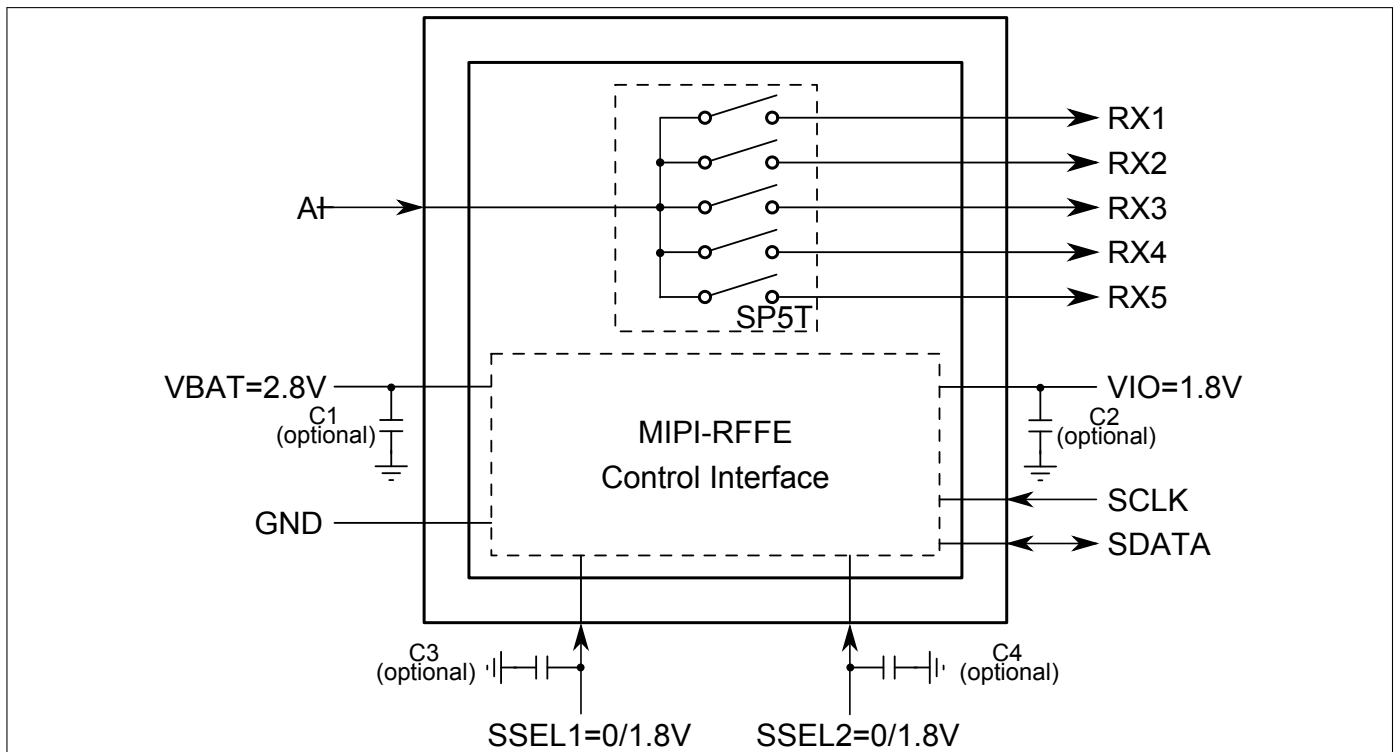

Figure 10: BGS15MA12 Application Schematic

Table 13: Bill of Materials Table

Name	Value	Package	Manufacturer	Function
C1 (optional)	1 nF	0201	Various	RF Bypass ¹⁾
C2 (optional)	1 nF	0201	Various	RF Bypass ¹⁾
C3 (optional)	1 nF	0201	Various	RF Bypass ¹⁾
C4 (optional)	1 nF	0201	Various	RF Bypass ¹⁾
N1	BGS15MA12	ATSLP-12-4	Infineon	RF MOS Switch

¹⁾ RF bypass recommended to mitigate power supply noise

8 Package Information

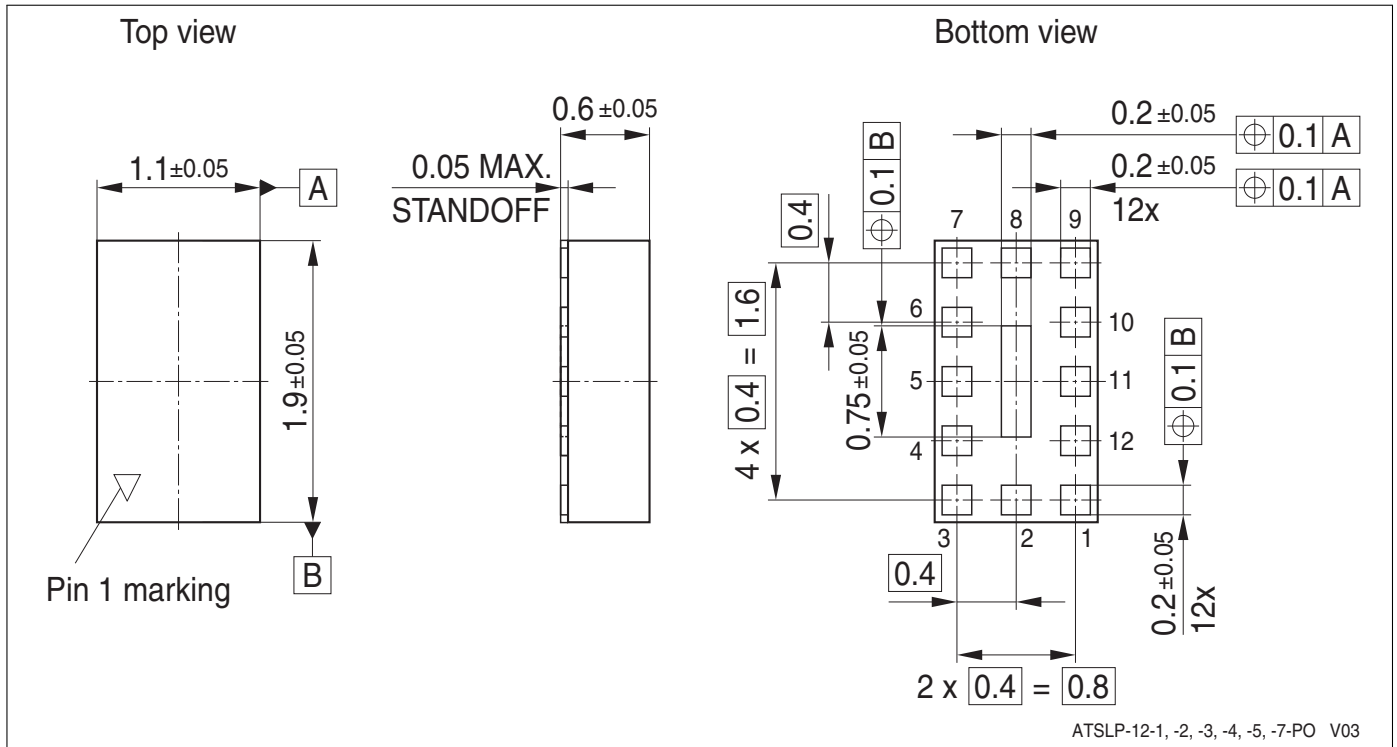

Figure 11: ATSLP-12-4 Package Outline (top, side and bottom views)

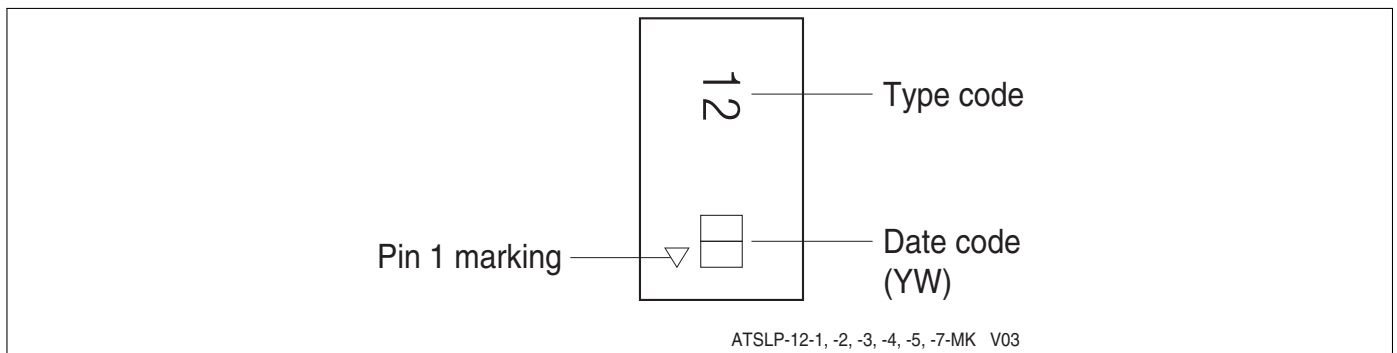

Figure 12: Marking Specification (top view)

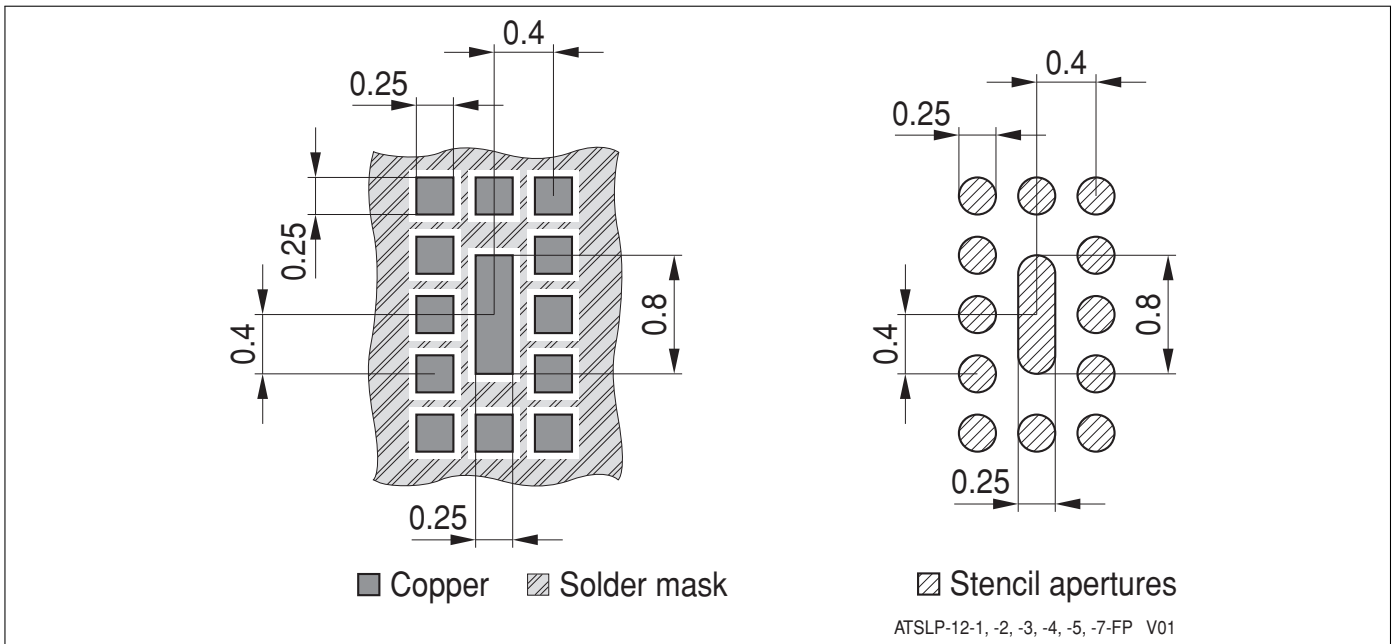

Figure 13: Footprint Recommendation

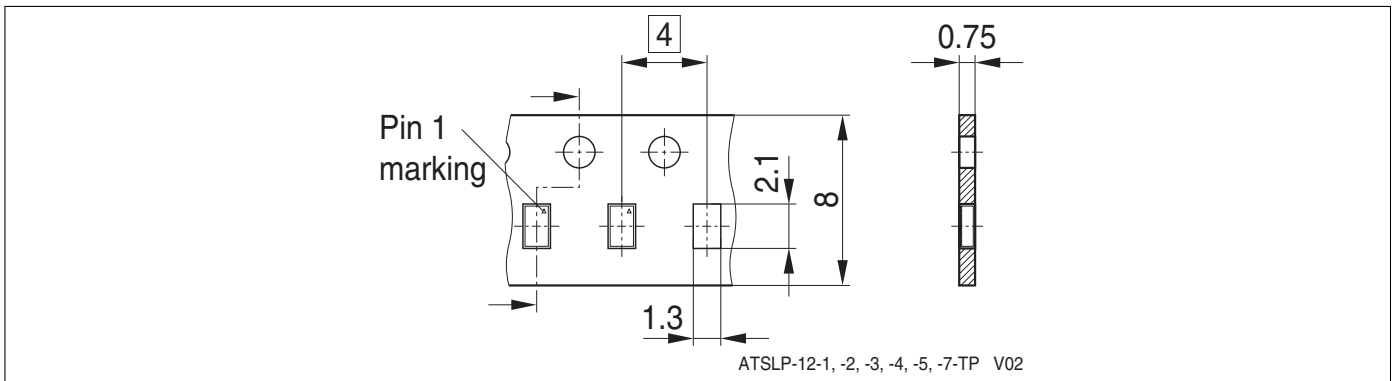



Figure 14: ATSLP-12-4 Carrier Tape

www.infineon.com

Published by Infineon Technologies AG

Looking for pricing, stock, or lifecycle information?

Click below to explore more details on WIN SOURCE:

-  [View BGS15MA12E6327XTSA1 on WIN SOURCE](#)
-  [Infineon Technologies Information](#)

Optimize Your Supply Chain with WIN SOURCE Solutions

-  Global Sourcing Solution
-  Obsolete Management
-  Cost Control Management
-  Shortage Management
-  Alternative Solution
-  Excess Inventory Management