



**THE DATASHEET OF
PEMI6CSP/RW,135**



Important notice

Dear Customer,

On 7 February 2017 the former NXP Standard Product business became a new company with the tradename **Nexperia**. Nexperia is an industry leading supplier of Discrete, Logic and PowerMOS semiconductors with its focus on the automotive, industrial, computing, consumer and wearable application markets

In data sheets and application notes which still contain NXP or Philips Semiconductors references, use the references to Nexperia, as shown below.

Instead of <http://www.nxp.com>, <http://www.philips.com/> or <http://www.semiconductors.philips.com/>, use <http://www.nexperia.com>

Instead of sales.addresses@www.nxp.com or sales.addresses@www.semiconductors.philips.com, use salesaddresses@nexperia.com (email)

Replace the copyright notice at the bottom of each page or elsewhere in the document, depending on the version, as shown below:

- © NXP N.V. (year). All rights reserved or © Koninklijke Philips Electronics N.V. (year). All rights reserved

Should be replaced with:

- © **Nexperia B.V. (year). All rights reserved.**

If you have any questions related to the data sheet, please contact our nearest sales office via e-mail or telephone (details via salesaddresses@nexperia.com). Thank you for your cooperation and understanding,

Kind regards,

Team Nexperia

PEMIXCSP family

Integrated 4-, 6- and 8-channel passive filter network with ESD protection

Rev. 2 — 27 January 2012

Product data sheet

1. Product profile

1.1 General description

The devices are a family of 4-, 6- and 8-channel RC low pass filters which are designed to provide filtering of undesired RF signals on the I/O ports of portable communication or computing devices. In addition the devices incorporate diodes to provide protection to downstream components from ElectroStatic Discharge (ESD) voltages up to ± 20 kV.

The PEMIXCSP family is fabricated using monolithic silicon technology and integrates up to eight resistors and 16 protection diodes in a single Wafer Level Chip-Size Package (WLCSP).

These features make the devices ideal for use in applications requiring the utmost in miniaturization such as mobile phone handsets, cordless telephones and personal digital devices.

1.2 Features and benefits

- Pb-free, Restriction of Hazardous Substances (RoHS) compliant and free of halogen and antimony (Dark Green compliant)
- Integrated 4-, 6- and 8-channel π -type RC filter network
- Channel series resistance $R_{S(ch)} = 100 \Omega$
- Channel capacitance $C_{ch} = 23$ or 30 pF at $V_{bias(DC)} = 2.5$ V
- Channel capacitance $C_{ch} = 41$ or 54 pF at $V_{bias(DC)} = 0$ V
- Available in 10, 15 and 20-ball WLCSP
- ESD protection up to ± 20 kV contact discharge according to IEC 61000-4-2, far exceeding level 4

1.3 Applications

General-purpose ElectroMagnetic Interference (EMI) and Radio-Frequency Interference (RFI) filtering and downstream ESD protection for:

- Cellular phone and Personal Communication Systems (PCS) mobile handsets
- Cordless telephones
- Wireless data (WAN/LAN) systems



2. Pinning information

2.1 Pinning

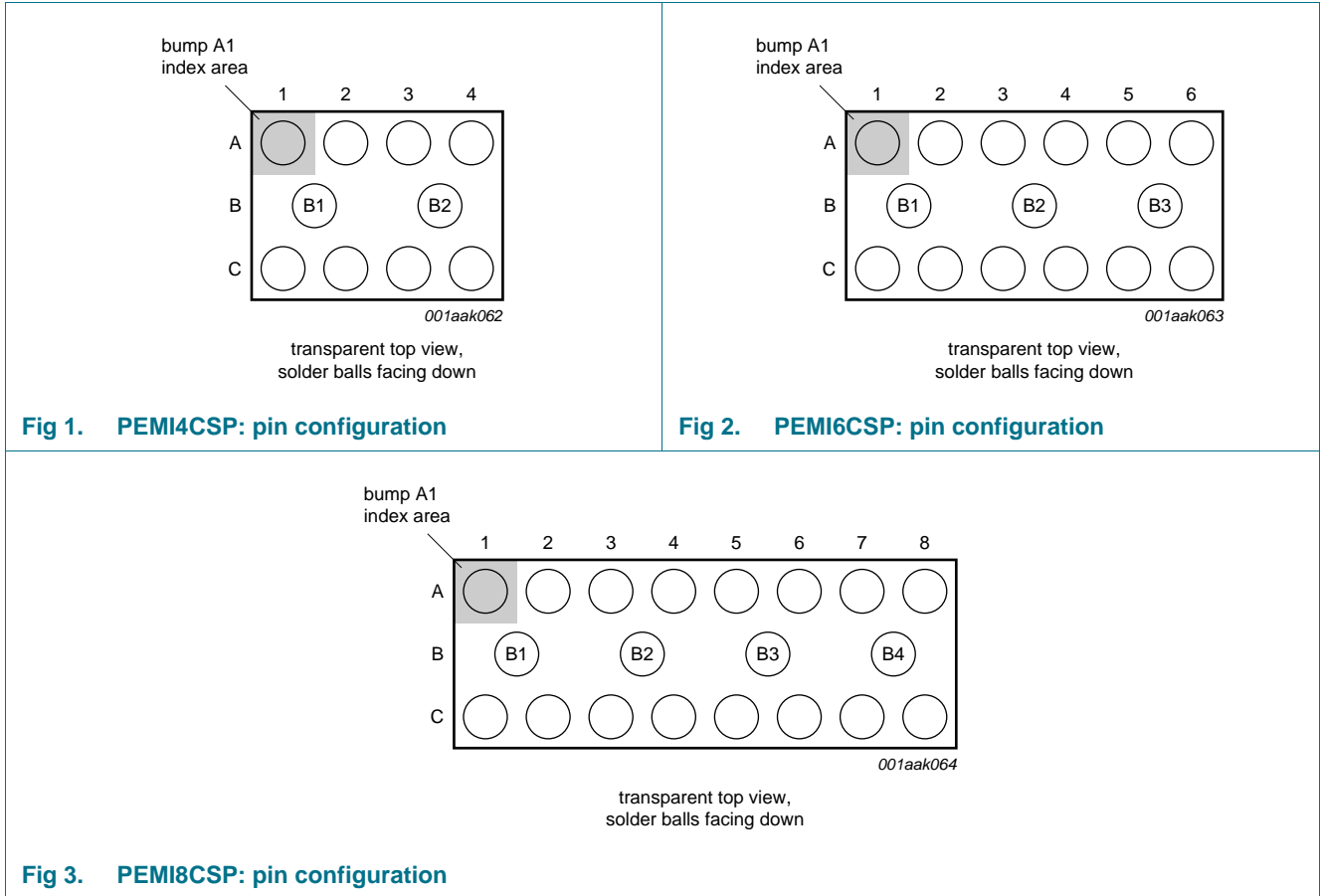

2.2 Pin description

Table 1. Pinning

Pin	PEMI4CSP	PEMI6CSP	PEMI8CSP	Description
A1 and C1	A1 and C1	A1 and C1	A1 and C1	filter channel 1
A2 and C2	A2 and C2	A2 and C2	A2 and C2	filter channel 2
A3 and C3	A3 and C3	A3 and C3	A3 and C3	filter channel 3
A4 and C4	A4 and C4	A4 and C4	A4 and C4	filter channel 4
-	-	A5 and C5	A5 and C5	filter channel 5
-	-	A6 and C6	A6 and C6	filter channel 6
-	-	-	A7 and C7	filter channel 7
-	-	-	A8 and C8	filter channel 8
B1 and B2	B1, B2 and B3	B1, B2 and B3	B1, B2, B3 and B4	ground (GND)

3. Ordering information

Table 2. Ordering information

Type number	Package		Version
	Name	Description	
PEMI4CSP/RT	WLCSP10	wafer level chip-size package; 10 bumps; 1.56 × 1.05 × 0.61 mm	PEMI4CSP/RT
PEMI4CSP/RW	WLCSP10	wafer level chip-size package; 10 bumps; 1.56 × 1.05 × 0.61 mm	PEMI4CSP/RW
PEMI6CSP/RT	WLCSP15	wafer level chip-size package; 15 bumps; 2.36 × 1.05 × 0.61 mm	PEMI6CSP/RT
PEMI6CSP/RW	WLCSP15	wafer level chip-size package; 15 bumps; 2.36 × 1.05 × 0.61 mm	PEMI6CSP/RW
PEMI8CSP/RT/P	WLCSP20	wafer level chip-size package; 20 bumps; 3.16 × 1.05 × 0.61 mm	PEMI8CSP/RT/P
PEMI8CSP/RW/P	WLCSP20	wafer level chip-size package; 20 bumps; 3.16 × 1.05 × 0.61 mm	PEMI8CSP/RW/P

4. Functional diagram

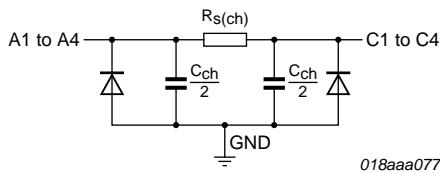

Fig 4. PEMI4CSP: schematic diagram

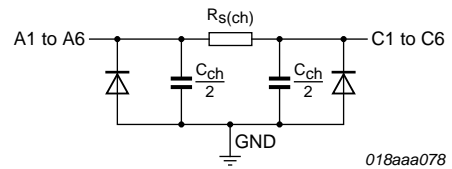

Fig 5. PEMI6CSP: schematic diagram

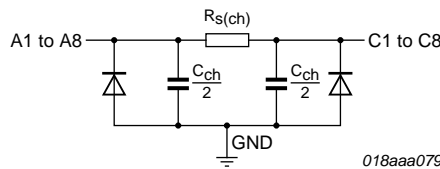

Fig 6. PEMI8CSP: schematic diagram

5. Limiting values

Table 3. Limiting values

In accordance with the Absolute Maximum Rating System (IEC 60134).

Symbol	Parameter	Conditions	Min	Max	Unit
V_{CC}	supply voltage		-0.5	+5.6	V
V_{ESD}	electrostatic discharge voltage	all pins to ground	[1]		
		contact discharge	-	±20	kV
		air discharge	-	±30	kV
		IEC 61000-4-2, level 4 all pins to ground			
		contact discharge	-	±8	kV
		air discharge	-	±15	kV
I_{ch}	channel current (DC)	$T_{amb} = 70\text{ °C}$	-	33	mA
P_{ch}	channel power dissipation	continuous power; $T_{amb} = 70\text{ °C}$	-	60	mW
P_{tot}	total power dissipation	continuous power; $T_{amb} = 70\text{ °C}$	-	250	mW
T_{stg}	storage temperature		-55	+150	°C
T_{amb}	ambient temperature		-40	+85	°C

[1] Device is qualified with 1000 pulses of ±15 kV contact discharges each, according to the IEC 61000-4-2 model and far exceeds the specified level 4 (8 kV contact discharge).

6. Characteristics

Table 4. Channel characteristics

$T_{amb} = 25\text{ °C}$; unless otherwise specified.

Symbol	Parameter	Conditions	Min	Typ	Max	Unit	
$R_{s(ch)}$	channel series resistance		80	100	120	Ω	
C_{ch}	channel capacitance	for the total channel; $f = 100\text{ kHz}$	[1]				
		PEMIXCSP/RT	$V_{bias(DC)} = 0\text{ V}$	33	41	49	pF
			$V_{bias(DC)} = 2.5\text{ V}$	-	23	-	pF
		PEMIXCSP/RW	$V_{bias(DC)} = 0\text{ V}$	43	54	65	pF
			$V_{bias(DC)} = 2.5\text{ V}$	-	30	-	pF
		V_{BR}	breakdown voltage	positive clamp; $I_I = 1\text{ mA}$	5.8	-	9
V_F	forward voltage	negative clamp; $I_F = 1\text{ mA}$	-1.5	-	-0.4	V	
I_{LR}	reverse leakage current	per channel; $V_I = 3.5\text{ V}$	-	-	0.1	μA	
R_{dyn}	dynamic resistance	$I = 1\text{ A}$	[2]				
		positive transient	-	0.3	-	Ω	
		negative transient	-	0.85	-	Ω	

[1] Guaranteed by design.

[2] According to IEC 61000-4-5 and IEC 61000-4-9.

Table 5. Frequency characteristics

$T_{amb} = 25\text{ }^{\circ}\text{C}$; unless otherwise specified.

Symbol	Parameter	Conditions	Min	Typ	Max	Unit
α_{il}	insertion loss	$R_{source} = 50\ \Omega$; $R_L = 50\ \Omega$				
	PEMIXCSP/RT	$800\text{ MHz} < f_i < 3\text{ GHz}$	25	30	-	dB
		$f_i = 1.7\text{ GHz}$	-	35	-	dB
	PEMIXCSP/RW	$800\text{ MHz} < f_i < 3\text{ GHz}$	27	32	-	dB
$f_i = 1.7\text{ GHz}$		-	37	-	dB	
α_{ct}	crosstalk attenuation	$R_{source} = 50\ \Omega$; $R_L = 50\ \Omega$; $800\text{ MHz} < f_i < 3\text{ GHz}$	-	30	-	dB
f_{-3dB}	cut-off frequency	$R_{source} = 50\ \Omega$; $R_L = 50\ \Omega$				
	PEMIXCSP/RT		-	128	-	MHz
	PEMIXCSP/RW		-	98	-	MHz

7. Application information

7.1 Insertion loss

The devices are designed as EMI/RFI filters for multichannel interfaces.

All measurements were performed in a typical $50\ \Omega$ NetWork Analyzer (NWA) setup as shown in [Figure 7](#). The measured insertion loss in a $50\ \Omega$ system is depicted in [Figure 8](#).

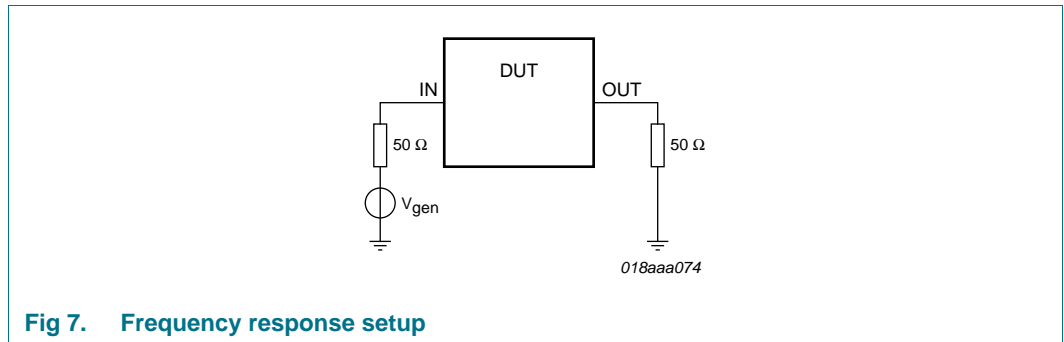
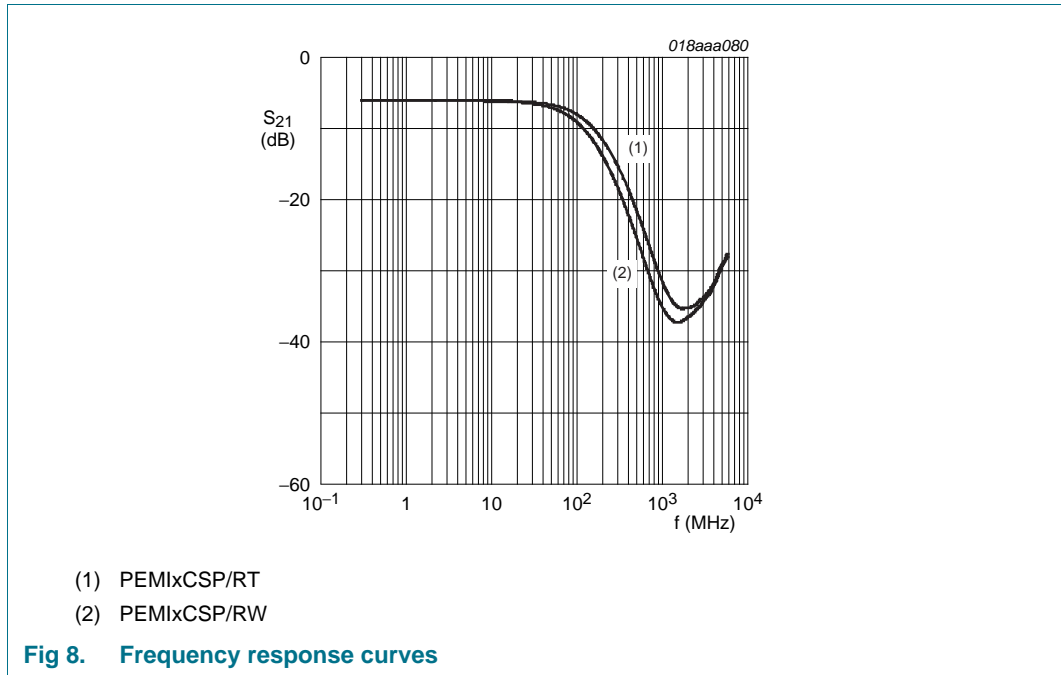

Fig 7. Frequency response setup



7.2 Use cases

The selection of one of the filter device has to be performed in dependence of the maximum clock frequency, the driver strength, the capacitive load of the sink and the maximum applicable rise and fall times.

7.3 LCD interfaces, medium-speed interfaces

For digital interfaces such as Liquid Crystal Display (LCD) interfaces running at clock speeds between 10 MHz and 25 MHz or more, the devices can be used in dependence of the sink load, the clock speed, the driver strength and the rise and fall time requirements. The minimum EMI filter requirements may be an important factor, too.

7.4 Keypad, low-speed interfaces

Especially for lower-speed interfaces such as keypads, low-speed serial interfaces and low-speed control signals, the PEMIXCSP family offers a very robust ESD protection and strong suppression of unwanted frequencies (EMI filtering). Due to their small size the devices can easily be spread on a Printed-Circuit Board (PCB) in order to move the ESD and EMI protection close to the part of the design which shall be protected.

8. Marking

All dies are laser-marked with the following information (see [Figure 9](#) and [10](#)):

- A marker indicating the pin A1 position.
- Two lines of characters or numbers:
 - The first line (placeholder <marking code>) indicates the marking code. Mapping of product type numbers to marking codes is given in [Table 6](#).
 - The second line (placeholder <lot ID>) indicates the production lot. This information enable to track a device down to a particular production date.

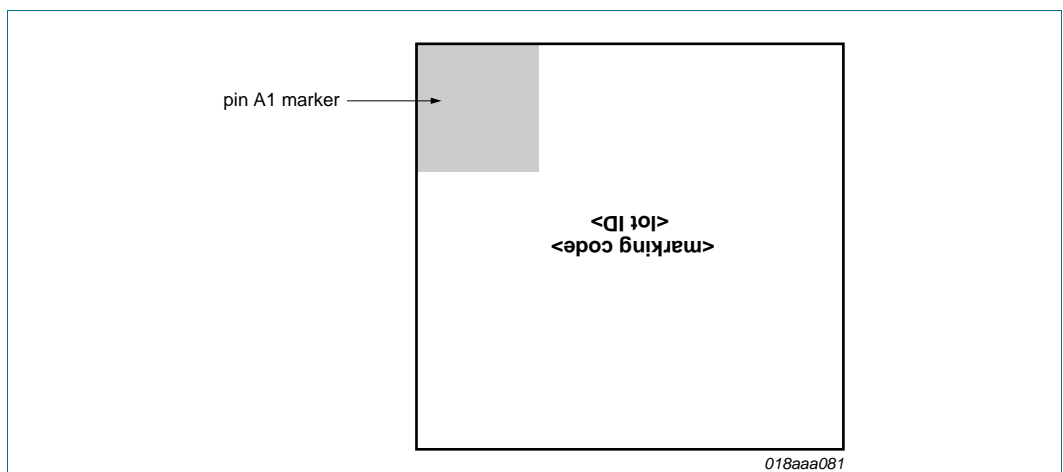

Fig 9. PEMI4CSP and PEMI6CSP: outline of the marking

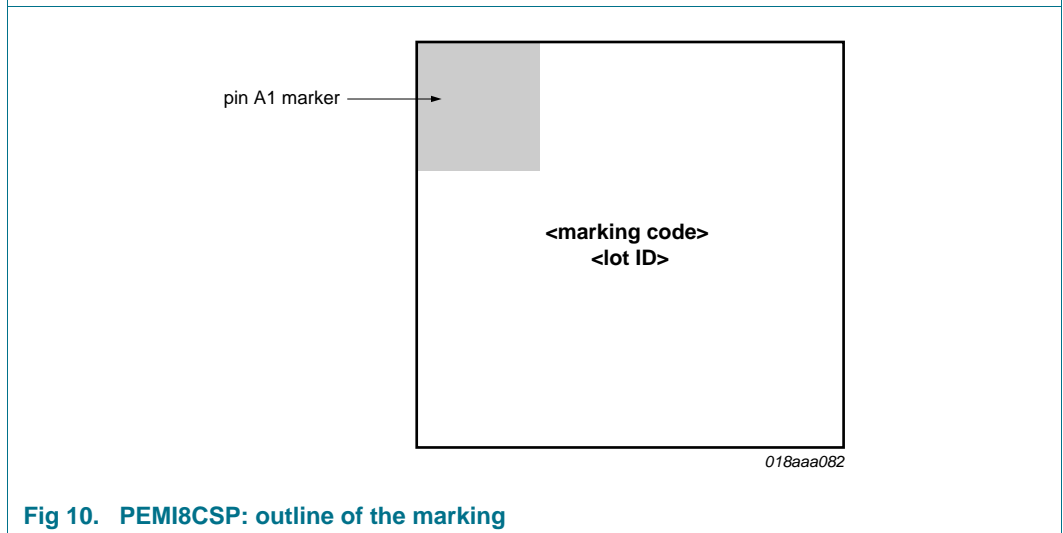

Fig 10. PEMI8CSP: outline of the marking

Table 6. Marking codes

Type number	Marking code	Type number	Marking code
PEMI4CSP/RT	RT	PEMI6CSP/RW	RW
PEMI4CSP/RW	RW	PEMI8CSP/RT/P	RT
PEMI6CSP/RT	RT	PEMI8CSP/RW/P	RW

9. Package outline

WLCSP10: wafer level chip-size package; 10 bumps (4-2-4)

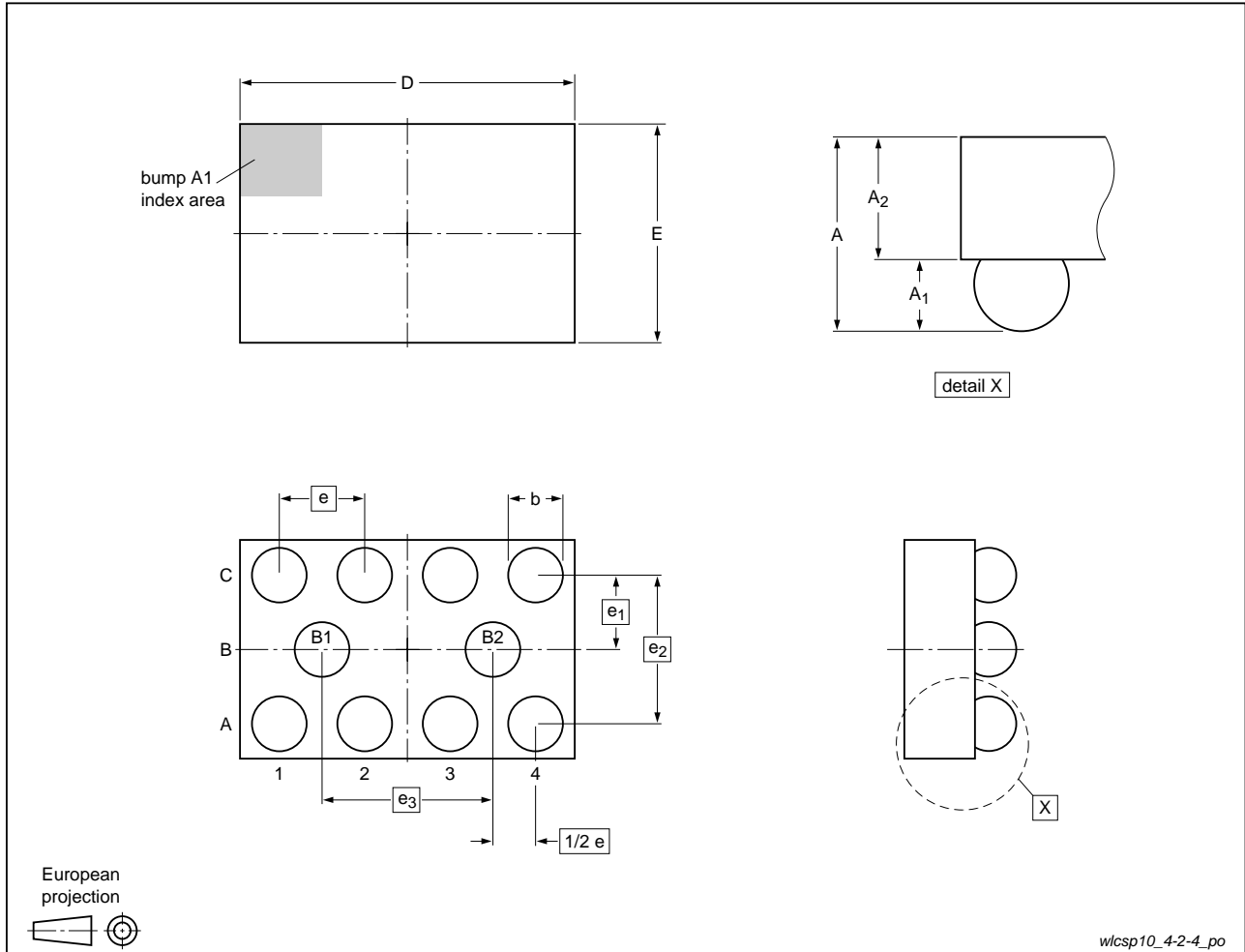

Fig 11. Package outline PEMI4CSP (WLCSP10)

Table 7. Package outline dimensions of PEMI4CSP

Symbol	Min	Typ	Max	Unit
A	0.57	0.61	0.65	mm
A ₁	0.18	0.20	0.22	mm
A ₂	0.39	0.41	0.43	mm
b	0.21	0.26	0.31	mm
D	1.51	1.56	1.61	mm
E	1.00	1.05	1.10	mm
e	-	0.4	-	mm
e ₁	-	0.346	-	mm
e ₂	-	0.692	-	mm
e ₃	-	0.8	-	mm

WLCSP15: wafer level chip-size package; 15 bumps (6-3-6)

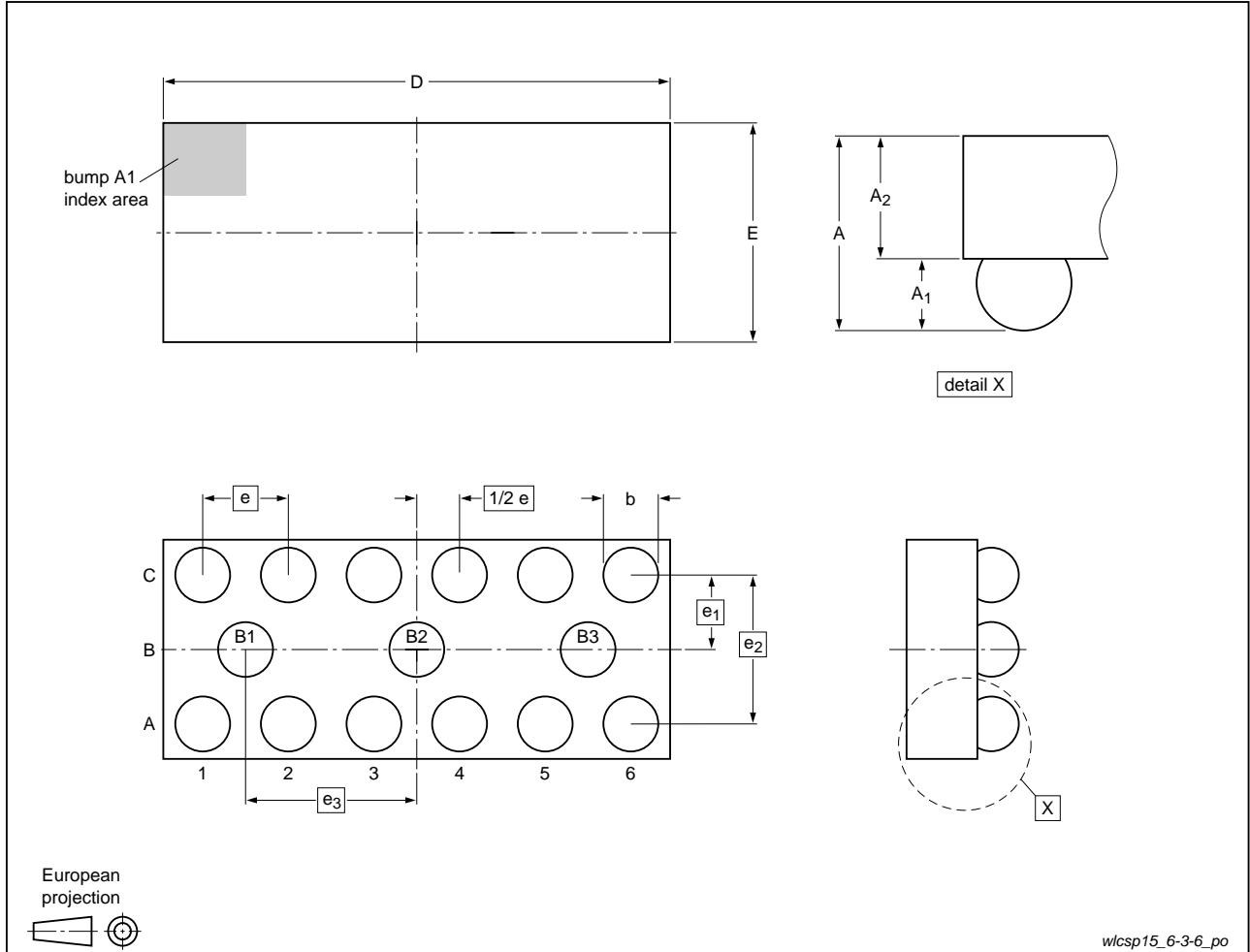

Fig 12. Package outline PEMI6CSP (WLCSP15)

Table 8. Package outline dimensions of PEMI6CSP

Symbol	Min	Typ	Max	Unit
A	0.57	0.61	0.65	mm
A ₁	0.18	0.20	0.22	mm
A ₂	0.39	0.41	0.43	mm
b	0.21	0.26	0.31	mm
D	2.31	2.36	2.41	mm
E	1.00	1.05	1.10	mm
e	-	0.4	-	mm
e ₁	-	0.346	-	mm
e ₂	-	0.692	-	mm
e ₃	-	0.8	-	mm

WLCSP20: wafer level chip-size package; 20 bumps (8-4-8)

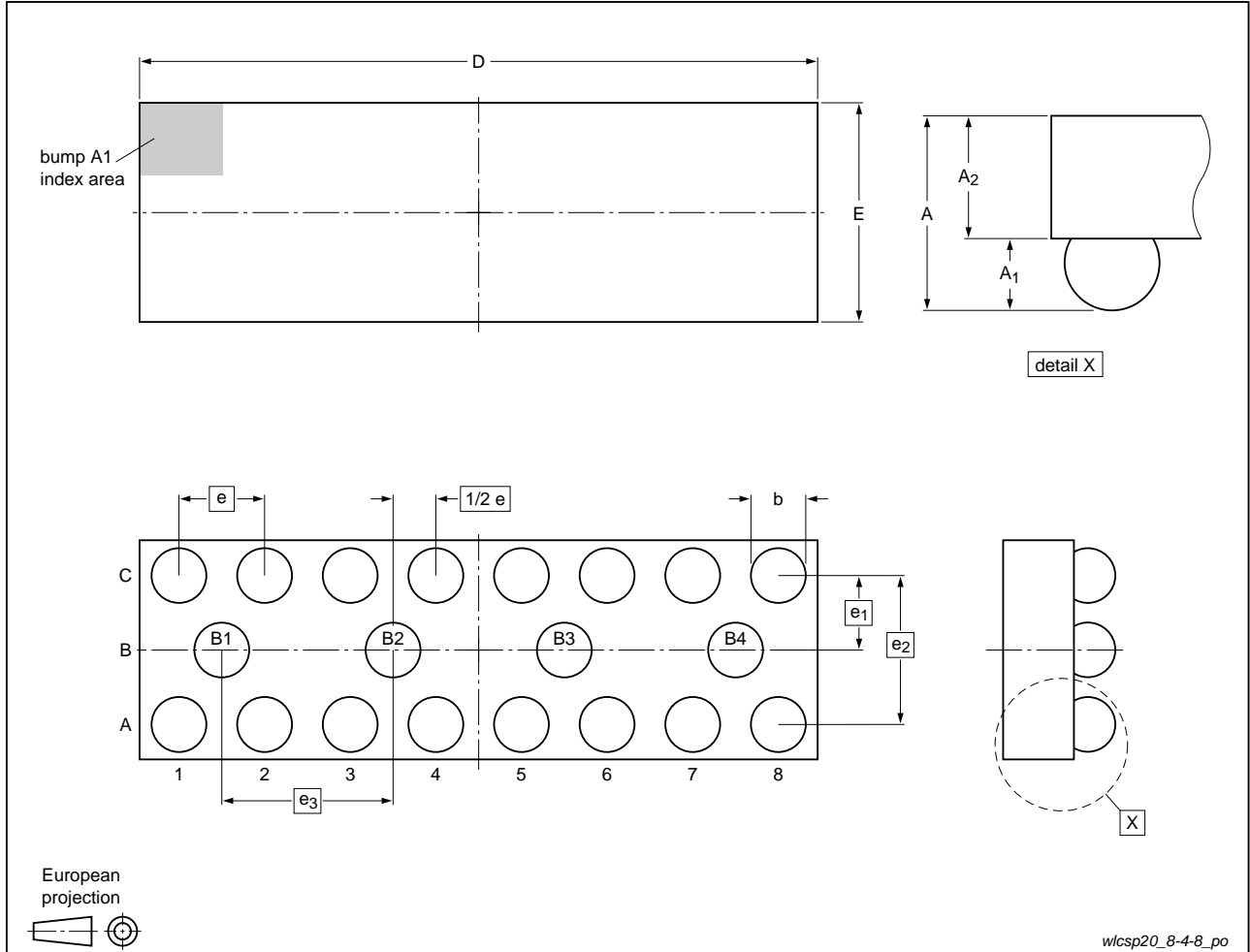

Fig 13. Package outline PEMI8CSP (WLCSP20)

Table 9. Package outline dimensions of PEMI8CSP

Symbol	Min	Typ	Max	Unit
A	0.57	0.61	0.65	mm
A ₁	0.18	0.20	0.22	mm
A ₂	0.39	0.41	0.43	mm
b	0.21	0.26	0.31	mm
D	3.11	3.16	3.21	mm
E	1.00	1.05	1.10	mm
e	-	0.4	-	mm
e ₁	-	0.346	-	mm
e ₂	-	0.692	-	mm
e ₃	-	0.8	-	mm

10. Design and assembly recommendations

10.1 PCB design guidelines

It is recommended, for optimum performance, to use a Non-Solder Mask Defined (NSMD), also known as a copper-defined design, incorporating laser-drilled micro-vias connecting the ground pads to a buried ground-plane layer. This results in the lowest possible ground inductance and provides the best high frequency and ESD performance. Refer to [Table 10](#) for the recommended Printed-Circuit Board (PCB) design parameters.

Table 10. Recommended PCB design parameters

Parameter	Value or specification
PCB pad diameter	250 μm
Micro-via diameter	100 μm (0.004 inch)
Solder mask aperture diameter	325 μm
Copper thickness	20 μm to 40 μm
Copper finish	AuNi
PCB material	FR4

10.2 PCB assembly guidelines for Pb-free soldering

Table 11. Assembly recommendations

Parameter	Value or specification
Solder screen aperture diameter	290 μm
Solder screen thickness	100 μm (0.004 inch)
Solder paste: Pb-free	SnAg (3 % to 4 %) Cu (0.5 % to 0.9 %)
Solder to flux ratio	50 : 50
Solder reflow profile	see Figure 14

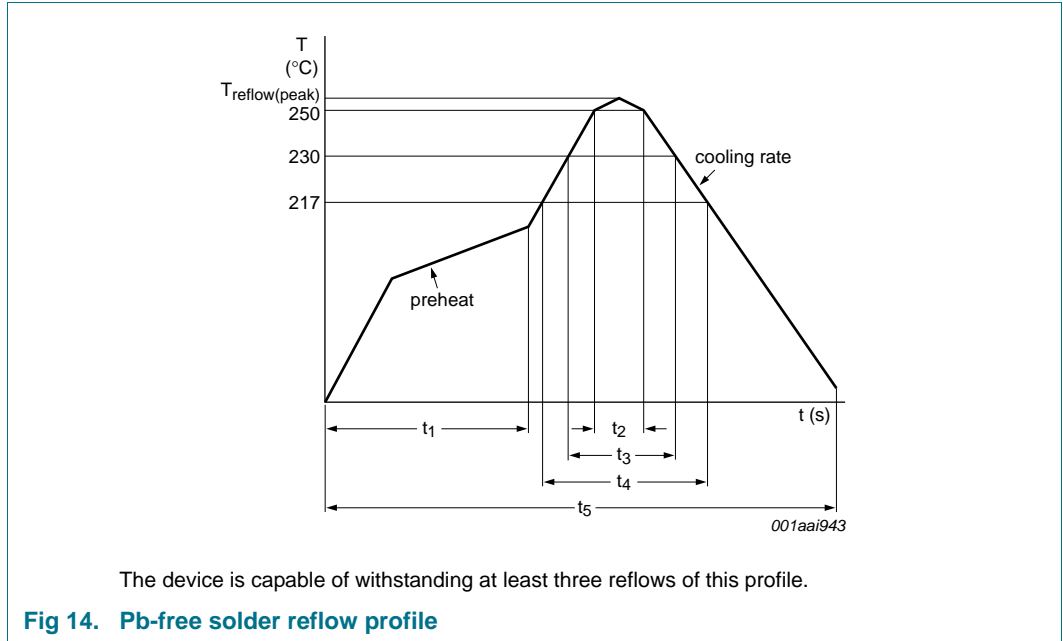

Table 12. Characteristics

Symbol	Parameter	Conditions	Min	Typ	Max	Unit
$T_{\text{reflow(peak)}}$	peak reflow temperature		230	-	260	°C
t_1	time 1	soak time	60	-	180	s
t_2	time 2	time during $T \geq 250\text{ °C}$	-	-	30	s
t_3	time 3	time during $T \geq 230\text{ °C}$	10	-	50	s
t_4	time 4	time during $T > 217\text{ °C}$	30	-	150	s
t_5	time 5		-	-	540	s
dT/dt	rate of change of temperature	cooling rate	-	-	-6	°C/s
		pre-heat	2.5	-	4.0	°C/s

11. Revision history

Table 13. Revision history

Document ID	Release date	Data sheet status	Change notice	Supersedes
PEMIXCSP_FAM v.2	20120127	Product data sheet	-	PEMIXCSP_FAM v.1
PEMIXCSP_FAM v.1	20110203	Product data sheet	-	-

12. Legal information

12.1 Data sheet status

Document status ^{[1][2]}	Product status ^[3]	Definition
Objective [short] data sheet	Development	This document contains data from the objective specification for product development.
Preliminary [short] data sheet	Qualification	This document contains data from the preliminary specification.
Product [short] data sheet	Production	This document contains the product specification.

[1] Please consult the most recently issued document before initiating or completing a design.

[2] The term 'short data sheet' is explained in section "Definitions".

[3] The product status of device(s) described in this document may have changed since this document was published and may differ in case of multiple devices. The latest product status information is available on the Internet at URL <http://www.nxp.com>.

12.2 Definitions

Draft — The document is a draft version only. The content is still under internal review and subject to formal approval, which may result in modifications or additions. NXP Semiconductors does not give any representations or warranties as to the accuracy or completeness of information included herein and shall have no liability for the consequences of use of such information.

Short data sheet — A short data sheet is an extract from a full data sheet with the same product type number(s) and title. A short data sheet is intended for quick reference only and should not be relied upon to contain detailed and full information. For detailed and full information see the relevant full data sheet, which is available on request via the local NXP Semiconductors sales office. In case of any inconsistency or conflict with the short data sheet, the full data sheet shall prevail.

Product specification — The information and data provided in a Product data sheet shall define the specification of the product as agreed between NXP Semiconductors and its customer, unless NXP Semiconductors and customer have explicitly agreed otherwise in writing. In no event however, shall an agreement be valid in which the NXP Semiconductors product is deemed to offer functions and qualities beyond those described in the Product data sheet.

12.3 Disclaimers

Limited warranty and liability — Information in this document is believed to be accurate and reliable. However, NXP Semiconductors does not give any representations or warranties, expressed or implied, as to the accuracy or completeness of such information and shall have no liability for the consequences of use of such information. NXP Semiconductors takes no responsibility for the content in this document if provided by an information source outside of NXP Semiconductors.

In no event shall NXP Semiconductors be liable for any indirect, incidental, punitive, special or consequential damages (including - without limitation - lost profits, lost savings, business interruption, costs related to the removal or replacement of any products or rework charges) whether or not such damages are based on tort (including negligence), warranty, breach of contract or any other legal theory.

Notwithstanding any damages that customer might incur for any reason whatsoever, NXP Semiconductors' aggregate and cumulative liability towards customer for the products described herein shall be limited in accordance with the *Terms and conditions of commercial sale* of NXP Semiconductors.

Right to make changes — NXP Semiconductors reserves the right to make changes to information published in this document, including without limitation specifications and product descriptions, at any time and without notice. This document supersedes and replaces all information supplied prior to the publication hereof.

Suitability for use — NXP Semiconductors products are not designed, authorized or warranted to be suitable for use in life support, life-critical or safety-critical systems or equipment, nor in applications where failure or malfunction of an NXP Semiconductors product can reasonably be expected to result in personal injury, death or severe property or environmental damage. NXP Semiconductors and its suppliers accept no liability for inclusion and/or use of NXP Semiconductors products in such equipment or applications and therefore such inclusion and/or use is at the customer's own risk.

Applications — Applications that are described herein for any of these products are for illustrative purposes only. NXP Semiconductors makes no representation or warranty that such applications will be suitable for the specified use without further testing or modification.

Customers are responsible for the design and operation of their applications and products using NXP Semiconductors products, and NXP Semiconductors accepts no liability for any assistance with applications or customer product design. It is customer's sole responsibility to determine whether the NXP Semiconductors product is suitable and fit for the customer's applications and products planned, as well as for the planned application and use of customer's third party customer(s). Customers should provide appropriate design and operating safeguards to minimize the risks associated with their applications and products.

NXP Semiconductors does not accept any liability related to any default, damage, costs or problem which is based on any weakness or default in the customer's applications or products, or the application or use by customer's third party customer(s). Customer is responsible for doing all necessary testing for the customer's applications and products using NXP Semiconductors products in order to avoid a default of the applications and the products or of the application or use by customer's third party customer(s). NXP does not accept any liability in this respect.

Limiting values — Stress above one or more limiting values (as defined in the Absolute Maximum Ratings System of IEC 60134) will cause permanent damage to the device. Limiting values are stress ratings only and (proper) operation of the device at these or any other conditions above those given in the Recommended operating conditions section (if present) or the Characteristics sections of this document is not warranted. Constant or repeated exposure to limiting values will permanently and irreversibly affect the quality and reliability of the device.

Terms and conditions of commercial sale — NXP Semiconductors products are sold subject to the general terms and conditions of commercial sale, as published at <http://www.nxp.com/profile/terms>, unless otherwise agreed in a valid written individual agreement. In case an individual agreement is concluded only the terms and conditions of the respective agreement shall apply. NXP Semiconductors hereby expressly objects to applying the customer's general terms and conditions with regard to the purchase of NXP Semiconductors products by customer.

No offer to sell or license — Nothing in this document may be interpreted or construed as an offer to sell products that is open for acceptance or the grant, conveyance or implication of any license under any copyrights, patents or other industrial or intellectual property rights.

Export control — This document as well as the item(s) described herein may be subject to export control regulations. Export might require a prior authorization from competent authorities.

Quick reference data — The Quick reference data is an extract of the product data given in the Limiting values and Characteristics sections of this document, and as such is not complete, exhaustive or legally binding.

Non-automotive qualified products — Unless this data sheet expressly states that this specific NXP Semiconductors product is automotive qualified, the product is not suitable for automotive use. It is neither qualified nor tested in accordance with automotive testing or application requirements. NXP Semiconductors accepts no liability for inclusion and/or use of non-automotive qualified products in automotive equipment or applications.

In the event that customer uses the product for design-in and use in automotive applications to automotive specifications and standards, customer (a) shall use the product without NXP Semiconductors' warranty of the product for such automotive applications, use and specifications, and (b) whenever customer uses the product for automotive applications beyond NXP Semiconductors' specifications such use shall be solely at customer's own risk, and (c) customer fully indemnifies NXP Semiconductors for any liability, damages or failed product claims resulting from customer design and use of the product for automotive applications beyond NXP Semiconductors' standard warranty and NXP Semiconductors' product specifications.

12.4 Trademarks

Notice: All referenced brands, product names, service names and trademarks are the property of their respective owners.

13. Contact information

For more information, please visit: <http://www.nxp.com>

For sales office addresses, please send an email to: salesaddresses@nxp.com

14. Contents

1	Product profile	1
1.1	General description	1
1.2	Features and benefits	1
1.3	Applications	1
2	Pinning information	2
2.1	Pinning	2
2.2	Pin description	2
3	Ordering information	3
4	Functional diagram	3
5	Limiting values	4
6	Characteristics	4
7	Application information	5
7.1	Insertion loss	5
7.2	Use cases	6
7.3	LCD interfaces, medium-speed interfaces	6
7.4	Keypad, low-speed interfaces	6
8	Marking	7
9	Package outline	8
10	Design and assembly recommendations	11
10.1	PCB design guidelines	11
10.2	PCB assembly guidelines for Pb-free soldering	11
11	Revision history	13
12	Legal information	14
12.1	Data sheet status	14
12.2	Definitions	14
12.3	Disclaimers	14
12.4	Trademarks	15
13	Contact information	15
14	Contents	16

Please be aware that important notices concerning this document and the product(s) described herein, have been included in section 'Legal information'.

© NXP B.V. 2012.

All rights reserved.

For more information, please visit: <http://www.nxp.com>



For sales office addresses, please send an email to: salesaddresses@nxp.com

Date of release: 27 January 2012

Document identifier: PEMIXCSP_FAM

Looking for pricing, stock, or lifecycle information?

Click below to explore more details on WIN SOURCE:

-  [View PEMI6CSP/RW,135 on WIN SOURCE](#)
-  [Nexperia USA Inc. Information](#)

Optimize Your Supply Chain with WIN SOURCE Solutions

-  Global Sourcing Solution
-  Obsolete Management
-  Cost Control Management
-  Shortage Management
-  Alternative Solution
-  Excess Inventory Management