



THE DATASHEET OF ZXLD1322DCCTC



ZXLD1322

BUCK/BOOST MODE DC-DC CONVERTER FOR LED DRIVING WITH 700mA OUTPUT AND CURRENT CONTROL

Description

The ZXLD1322 is an inductive DC-DC converter, with an internal switch, designed for driving single or multiple LEDs in series up to a total of 700mA output current. Applications cover input voltages ranging from 2.5V to 15V. Depending upon supply voltage and external components, this can provide up to 12W of output power. The device employs a variable 'on' and 'off' time control scheme with adjustable peak switch current limiting and operates in Buck/Boost mode, offering higher power efficiency and lower system cost than conventional PFM buck/boost circuitry. The device includes the DC-DC converter, a high-side current monitor and an NPN switching transistor to provide an integrated solution offering small PCB size, competitive cost/performance, high power efficiency of DC-DC conversion and maximum LED brightness/reliability. More importantly, it retains design flexibility to add customer specific features. The feedback control circuitry inside the ZXLD1322 provides excellent load and current regulation, resulting in very stable LED current over the useful life of the battery and over the full operating temperature range. The LED current can be adjusted from 100% down to 10% of the set value by applying a dc voltage to the ADJ pin and down to 1% by applying a PWM signal. An on-chip LED protection circuit also allows output current to be reduced linearly above a predetermined threshold temperature using an external thermistor at the TADJ pin. External resistors set nominal average LED current and coil peak current independently. The device can be shut down by applying a continuous low level dc voltage to the ADJ pin.

Features

- 2.5V to 15V Input Voltage Range
- Up to 700mA output current
- Typical efficiency[#] >80%
- User-defined thermal control of LED output current using external thermistor
- High output current stability over input voltage and temperature
- 12µA typical standby current
- LED current adjustable from 100% down to 2%
- Adjustable Soft-Start
- Capable of driving 3 LEDs in series

Applications

- High power LED flashlights
- LED back-up lighting
- General LED lighting

Typical Application Circuit

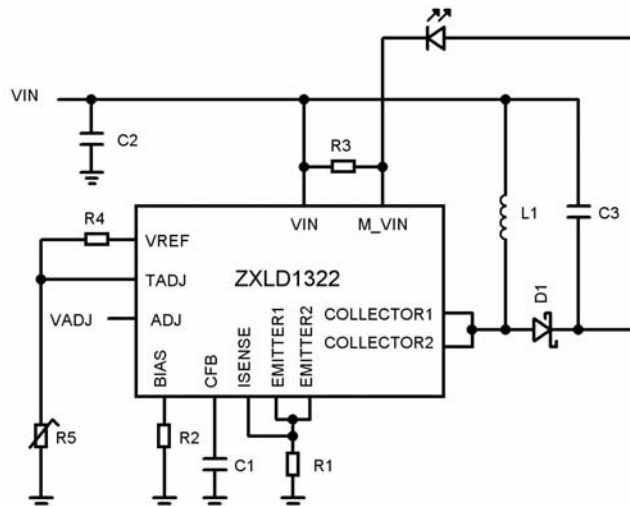

Notes: #. Using standard external components as specified under electrical characteristics. Efficiency is dependent upon external component types and values. Higher efficiency is possible with alternative coils.

Pin Assignments

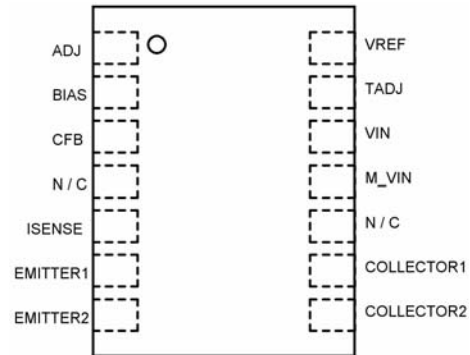

(Top View)

DFN4030-14 with Exposed Pad

4mm x 3mm

0.50mm pitch

1.5W @ $T_A = 70^\circ\text{C}$

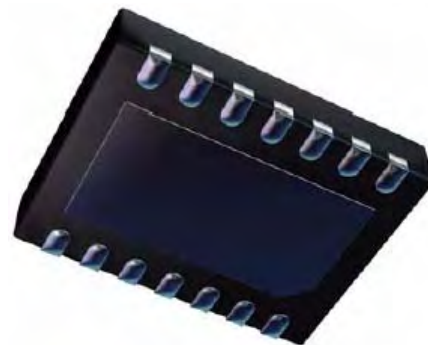

DFN4030-14 Package (Bottom View)

45° chamfer denote Pin 1

Block Diagram

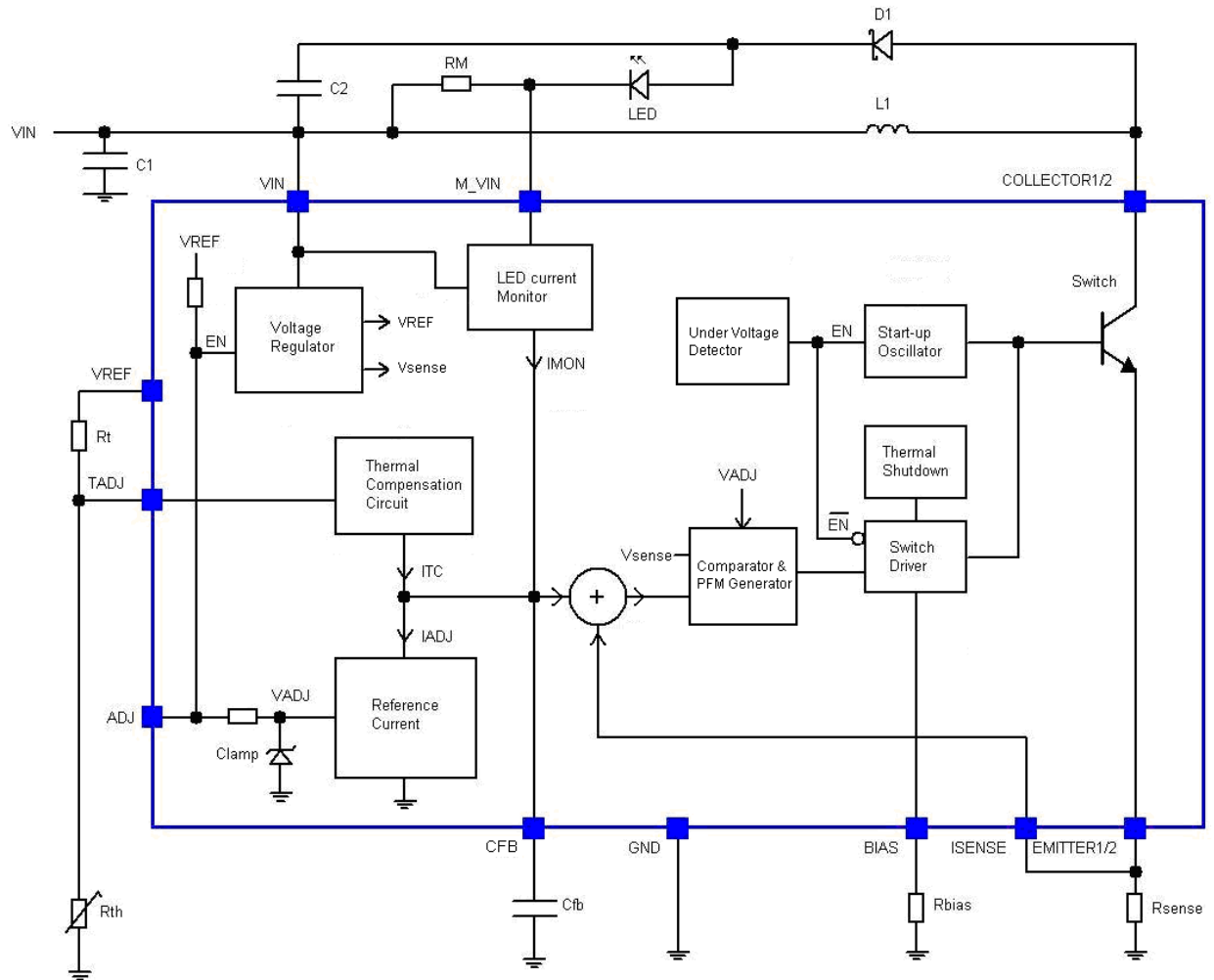

ZXLD1322 Block Diagram (showing external components)

Pin Description

Name	Pin #	Description
ADJ	1	Adjust input <ul style="list-style-type: none"> • Leave floating, or connect to V_{REF} to set 100% output current. • Drive with dc voltage. ($50mV < V_{ADJ} < V_{REF}$) to adjust output current from 10% to 100% of set value. (DC brightness control mode) • Drive with low frequency (200Hz) PWM control signal to gate output 'on' and 'off' at the PWM frequency. (PWM brightness control mode) • Drive with low level dc voltage ($V_{ADJ} < 28mV$) to turn off device (Standby mode)
BIAS	2	Bias pin for setting base current of internal switch transistor <ul style="list-style-type: none"> • Short pin to ground to define maximum base drive current for output switch (Maximum output current condition) • Connect resistor (R_{BIAS}) from this pin to ground to reduce base drive current (Reduced output current condition)
CFB	3	Control input/output for feedback control loop <ul style="list-style-type: none"> • Connect 10nF capacitor from this pin to ground to provide loop compensation
N/C	4	Not connected internally (Open circuit)
ISENSE	5	Switch peak current sense pin <ul style="list-style-type: none"> • Connect resistor (R_{SENSE}) from this pin to ground to define peak switch current ($I_{SWPEAK} = 0.05/R_S$)
EMITTER1	6	Switch emitters (Connect both pins to top of RSENSE to sense emitter current)
EMITTER2	7	
COLLECTOR2	8	Switch Collectors (Connect both pins to lower side of coil)
COLLECTOR1	9	
N/C	10	Internally connected - Do not connect to external circuitry
M_VIN	11	Input supply to high side current monitor <ul style="list-style-type: none"> • Connect output voltage (whichever is higher) • Connect resistor (R_M) from this pin to to V_{IN} to define nominal average output (LED) current of $0.1/R_M$
VIN	12	Input supply voltage and load side input of high side current monitor. Connect to sensing resistor R_M .
TADJ	13	Temperature Adjust input for LED thermal compensation <ul style="list-style-type: none"> • Connect thermistor/resistor network to this pin to reduce output current above a preset temperature threshold. • Connect to V_{REF} to disable thermal compensation function (see section on temperature control for details)
VREF	14	Internal 0.5V reference voltage output
Exposed Pad	15	Connect to ground (0V)

Absolute Maximum Ratings (Voltages to GND Unless Otherwise Stated)

Symbol	Parameter	Rating	Units
T _{OP}	Operating Temperature	-40 to 125	°C
T _{ST}	Storage Temperature	-55 to 150	°C
T _J	Junction Temperature	-40 to 150	°C
P _{TOT}	Package Power Dissipation DFN14 with Exposed Pad: 4mm x 3mm, 0.5mm Pitch	1.5 at T _{AMB} =70°C	W

DC-DC Converter

Supply Voltage (V _{IN})	-0.3V to +15V
ADJ	-0.3V to The lower of (+5.0V) or (V _{IN} + 0.3V)
CFB	-0.3V to The lower of (+5.0V) or (V _{IN} + 0.3V)
I _{SENSE}	-0.3V to The lower of (+5.0V) or (V _{IN} + 0.3V)
T _{ADJ}	-0.3V to The lower of (+5.0V) or (V _{IN} + 0.3V)
BIAS	-0.3V to The lower of (+5.0V) or (V _{IN} + 0.3V)

High-Side Current Monitor

Monitor Supply Voltage (M_VIN)	-0.3V to +15V
Continuous Sense Voltage (M_VIN – M_LOAD)	-0.3V to +5V

Switching NPN Transistor

Symbol	Parameter	Rating	Units
V _{CBO}	Collector-Base Voltage	18	V
V _{CEO}	Collector-Emitter Voltage	18	V
I _{CM}	Peak Pulse Current	3 (Pulsed Width = 300μs. Duty Cycle<=2%)	A
I _C	Continuous Collector Current	2	A

These are stress ratings only. Operation outside the absolute maximum ratings may cause device failure. Operation at the absolute maximum ratings for extended periods may reduce device reliability.

Thermal Resistance

Junction to ambient (R _{θJC})	Nominal Value
DFN4030-14	26.3°C/W

Electrical Characteristics (Test conditions: $V_{IN} = 4V$, $T_{AMB} = 25^{\circ}C$ unless otherwise stated^(a))

DC-DC Converter Supply Parameters

Symbol	Parameter	Condition	Min.	Typ.	Max.	Unit
V_{IN}	Supply Voltage	Normal Operation	2.5		15	V
$V_{IN(Start)}$	Supply voltage for start-up(b)	Start-up mode	1.2		2.4	V
V_{UV-}	Under-voltage detection threshold normal operation to start-up mode	V_{IN} falling		1.8		V
V_{UV+}	Under-voltage detection threshold start-up mode to normal operation	V_{IN} rising		2.2		V
I_q	Quiescent Current	Measured into V_{IN} ADJ pin floating. Excluding switch base current).		1.5		mA
I_{STBY}	Standby Current	Measured into V_{IN} . ADJ pin grounded		12	20	μA
V_{REF}	Internal Reference Voltage	ADJ pin floating $2.5V < V_{IN} < 15V$	480	500	520	mV
$T_{CO(REF)}$	Internal Reference Temperature Coefficient			50		ppm/K

Notes: (a) Production testing of the device is performed at 25°C. Functional operation of the device and parameters specified from -40°C to +125°C are guaranteed by design, characterization and process control.
(b) Between 1.2V and 2.2V the device will run in the Low Voltage Startup Mode (for details refer to section "Low Voltage Operation")

DC-DC Converter Input Parameters

Symbol	Parameter	Condition	Min.	Typ.	Max.	Unit
V_{SENSE}	Peak switch current sense voltage	Measured on I_{SENSE} pin CFB pin at 0V	45	55	65	mV
$V_{SENSE(SU)}$	Peak switch current sense voltage in start-up mode	Measured on I_{SENSE} pin. Start-up mode $V_{IN} = 1.2V$		10.5		mV
I_{SENSE}	Sense input current	Measured into I_{SENSE} with pin at 0V. CFB pin at 0V	-15	-7	-1	μA
C_{FB}	Control loop compensation capacitor			10		
V_{ADJ}	External DC control voltage applied to ADJ pin to adjust output current	DC brightness control mode	50		500	mV
$V_{ADJ(th)}$	Switching threshold of ADJ pin	Standby state to normal operation	26	28	30	mV
$T_{CO}(V_{ADJ})$	Temperature coefficient of $V_{ADJ(th)}$			+0.3		%/K
R_{ADJ}	Internal resistor between V_{REF} and ADJ	$V_{ADJ} < 550mV$		100		k Ω
$V_{ADJ}(CLMP)$	Clamp voltage on ADJ pin	100 μA injected into ADJ pin		575		mV

DC-DC Converter Output Parameters

Symbol	Parameter	Condition	Min.	Typ.	Max.	Unit
$T_{off(100)}$	Discharge pulse width	100% Output current	0.7	1.2	1.7	μs
$T_{off(10)}$	Discharge pulse width	10% Output current	4	8	12	μs
f_{LXMAX}	Maximum operating frequency				600	KHz
f_{SU}	Switching frequency in start-up mode	$V_{IN} = 1.2V$		50		KHz

Switching NPN Transistor

Symbol	Parameter	Condition	Min.	Typ.	Max.	Unit
I_{SW}	Average continuous switch current ^(c)				2	A
$I_{BON(max)}$	Maximum base current into switch transistor from internal drive circuit ^(d)	$2V < V_{IN} < 18V$ BIAS pin at 0V	30	50	70	mA
I_{BON}	Base current into switch transistor using external resistor (R_{BASE}) from BIAS pin to ground	$R_{BIAS} = 1680\Omega$		10		mA
$V_{(BR)CE}$	Collector-Emitter breakdown voltage	$I_C = 10mA$	15			V
$V_{CE(sat)}$	Collector-Emitter saturation voltage	$I_C = 0.1A, I_B = 10mA$ $I_C = 2A, I_B = 50mA$ ^(e)		50 120		mV
h_{FE}	Static forward current transfer ratio	$I_C = 200mA, V_{CE} = 2V$ $I_C = 2A, V_{CE} = 2V$		209 116		
C_{OBO}	Output capacitance	$V_{CB} = 10V, f = 1MHz$		64		pF
$t_{(on)}$	Turn-on time	$I_C = 0$ to $I_C = 2A$ $V_{IN} = 10V$		30		ns
$t_{(off)}$	Turn-off time	$I_C = 2A$ to $I_C < 100\mu A$		28		ns

High-Side Current Monitor

Symbol	Parameter	Condition	Min.	Typ.	Max.	Unit
V_{M_VIN}	Supply voltage		2.5		18	V
V_{MON}	Sense voltage	$= V_{(VIN)} - V_{M_VIN}$	0	100	200	mV
I_{M_VIN}	Input current	Measured into M_VIN pin		0.08	1	μA
$TCO_{(MON)}$	Temperature coefficient	$V_{MON} = 10mV$ $V_{MON} = 100mV$		370 150		ppm/K
BW	Bandwidth	$V_{MON} = 10mV$ $V_{MON} = 100mV$		350 2.5		KHz Mhz
Gm	Tran conductance $\Delta I_{OUT} / \Delta V_{MON}$			1		mA/V
ACC	Accuracy	$R_M = 0.1\Omega$ $V_{MON} = 100mV$	-3		3	%

Reference Current Monitor

Symbol	Parameter	Condition	Min.	Typ.	Max.	Unit
V_{ADJ}	Adjust Voltage		0		500	mV
$TCO_{(MON)}$	Temperature coefficient	$V_{ADJ} = 50mV$ $V_{ADJ} = 500mV$		160 200		ppm/K
BW	Bandwidth	$V_{ADJ} = 50mV$ $V_{ADJ} = 500mV$		275 3		KHz Mhz
Gm	Tran conductance $\Delta I_{OUT} / \Delta V_{ADJ}$			200		$\mu A/V$
ACC	Accuracy	$V_{ADJ} = 500mV$	-3		3	%

Notes: (c) Measured under pulse conditions.
(d) This current is measured via the collectors and emitters of the switch with these connected to ground (0V)
(e) Measured under pulse conditions. Peak Current = I_C

LED Thermal Control Circuit (T_{ADJ}) Parameters

Symbol	Parameter	Condition	Min.	Typ.	Max.	Unit
V_{TADJH}	Upper threshold voltage	Onset of output current reduction (V_{TADJ} falling)		75		mV
V_{TADJL}	Lower threshold voltage	Output current reduced to <10% of set value (V_{TADJ} falling)		50		mV
$G_{m(TADJ)}$	Trans conductance $\Delta I_{OUT}/\Delta V_{TADJ}$			4		mA/V

Output Current Regulation Parameters

Symbol	Parameter	Condition	Min.	Typ.	Max.	Unit
I_{OUT}	Minimum output/ LED current	$V_{IN} > 3V$		0.75		A
ΔI_{OUT}	Output current accuracy ^(g)	$3.0V < V_{IN} < 15V$, $I_{OUT} = 700mA$, $V_{ADJ} = 100mV$,	-5		+5	%
TCO $I_{(OUT)}$	Output current temperature drift	$3.0V < V_{IN} < 15V$, $I_{out} = 700mA$, $V_{ADJ} = 100mV$		100	200	ppm/K
$\Delta I_{OUT}/I_{OUT}$	Load Current Regulation	$350mA < I_{(LED)} < 700mA$		2		%/A
$\Delta I_{OUT}/\Delta V_{IN}$	Line Voltage Regulation of output current			0.5		%/V
Eff	Efficiency ^(f)	$350mA < I_{(LED)} < 700mA$		85		%

Notes: (f) System parameter only. This value is dependent upon external components and circuit configuration.

(g) This refers to the accuracy of output current regulation under normal operation when the feedback loop incorporating the current monitor is active. The tolerances of external components are not included in this figure.

Device Description

The ZXLD1322 is a buck/boost mode inductive DC-DC converter, with an internal switch, designed for driving single or multiple LEDs in series up to a total of 700mA output current. Depending upon supply voltage (V_{IN}), LED forward voltage drop (V_{LED}) and circuit configuration, this can provide up to 12W of output power.

Applications cover V_{IN} ranging from 2.5V to 15V.

The device employs a modified Pulse Frequency Modulation (PFM) control scheme, with variable "ON" and "OFF" time control and adjustable peak switch current limiting.

General device operation (refer to block diagram)

Normal Operation

Control is achieved by sensing the LED current in a series resistor (R_M), connected between the two inputs of the LED Current Monitor. This generates a proportional current (I_{MON}) that charges the external integrator capacitor CFB. I_{MON} is balanced against a reference discharge current (I_{ADJ}) generated at the output of a second voltage to current converter driven from the demand voltage (V_{ADJ}) on the ADJ pin. The difference between I_{MON} and I_{ADJ} is integrated by CFB to produce an error voltage. A comparator takes a summed version of the voltage at the I_{SENSE} pin and a fraction of this CFB voltage and resets the latch driving the switch when the sum is greater than 50mV. The switch transistor is turned on by the output of the SR latch, which remains set until the emitter current in the switch transistor produces a voltage drop V_{SENSE} (=50mV nominal) in external resistor R_{SENSE} , defining a preset maximum switch current of $50mV/R_{SENSE}$. Operation is such that a rising error voltage on CFB will effectively lower the voltage required on the I_{SENSE} pin and therefore reset the latch earlier in the switching cycle. This will reduce the 'ON' time of the switch and reduce the peak current in the switch from its preset maximum value. Similarly, a falling error voltage will reset the latch later and the peak switch current will be increased. The control loop therefore reduces or increases the energy stored in the coil during each switching cycle, as necessary, to force the LED current to the set value. This results in high accuracy, as no error is needed in the LED current to drive the servo to the required region.

The time taken for the coil current to reach the peak value depends on several factors: the supply voltage, the peak coil current required at that particular LED power and whether the system operates in "continuous" or "discontinuous" mode. The time allowed for the coil current to discharge into the LED is fixed by the 'Variable Off Delay' monostable, whose period is modified by the power demand signal on the ADJ pin. This monostable determines the time for which the latch remains reset (switch off) and provides a longer "OFF" period at lower power settings, helping to keep the parameters within an acceptable range.

Note that the "ON" period and the "OFF" period are set by the supply voltage, LED power and external components chosen. The frequency is therefore determined by these parameters and is NOT fixed. In this modified PFM scheme, the external components can be chosen to keep the frequency well above the audio range for all extremes of parameters, so no audible whistling should ever occur.

The 500mV reference voltage defines the nominal V_{ADJ} voltage and this defines the 100% output current. For lower LED currents, the ADJ pin can be-driven from an external DC voltage ($50mV < V_{ADJ} < 500mV$) or a low frequency Pulse Width Modulated (PWM) waveform.

Low voltage operation (start-up mode)

For supply voltages below 2V, the normal control loop will have insufficient headroom to operate reliably. This condition is detected by the 'under-voltage comparator', which compares a fraction of the internal supply voltage (V_{CC}) against V_{REF} . When the comparator output is active ($V_{CC} < 1.8V$), the output of the normal switch drive circuit is disabled and an alternative 'Start-up oscillator and driver' enabled. The start-up oscillator provides a nominal 50kHz fixed frequency drive signal to the base of the switch transistor, which is independent of V_{ADJ} and the voltage on CFB. Under low voltage conditions, the peak current in the coil ramps to approximately 25% of the normal value and the "OFF" time is fixed.

The low voltage start-up mode allows the device to operate down to 1.2V nominal. This allows the chip to work from a single cell.

ADJ pin

The ADJ pin is connected to the internal 500mV reference (V_{REF}) via a 100k resistor. This biases the ADJ pin to the reference voltage and defines nominal 100% LED current.

The ADJ pin can be overdriven with an external dc voltage between 50mV and 500mV to reduce the LED current proportionally between 10% and 100% of the nominal value.

LED current can also be adjusted by applying a low frequency PWM signal to the ADJ pin to turn the device On and Off. This will produce an average output current proportional to the duty cycle of the control signal.

The device can be shut down by shorting the ADJ pin to ground, or pulling it to a voltage below 28mV with a suitable open collector NPN or open drain NMOS transistor. In the shutdown state, most of the circuitry inside the device is switched off and residual quiescent current will be typically 12 μ A.

Thermal control of LED current

The 'Thermal compensation current' circuit produces a sourcing current (I_{TC}) which is zero for voltages above 75mV on T_{ADJ} and increases to 100 μ A when T_{ADJ} falls to 50mV. This current is summed into the control node and subtracted from the demand current, causing LED current to reduce from 100% down to zero over this input range. The potential divider, consisting of a fixed resistor R_t and an NTC Thermistor R_{th} between V_{REF} and ground, defines the voltage on T_{ADJ} and sets the threshold temperature. Further details are given in the application notes.

The Thermal Control feature can be disabled by leaving the T_{ADJ} pin floating, or by connecting it to V_{REF} .

Over-temperature shutdown

The ZXLD1322 incorporates an over-temperature shutdown circuit to protect the device against damage caused by excess die temperature, resulting from excessive power dissipation in the switch. The output of the 'Over-temp Shutdown' circuit will go high when the die temperature exceeds 150°C (nominal). This will turn off the drive to the switch during normal operation. Operation will resume when the device has cooled to a safe level.

Application Notes

Setting Peak Coil Current

The peak current in the coil is set by the resistor (RSENSE) between the switch emitter and ground according to:

$$I_{SWPEAK} = \frac{50mV}{R_{SENSE}}$$

The minimum peak current will depend on operating mode, coil inductance and supply voltage range. The maximum peak current must not exceed the specified value for the switch. (See Application circuits for details)

Setting LED Current

The nominal average LED current is given by:

$$I_{LED(NOM)} = \frac{100mV}{R_M}$$

Where R_M is the external resistor connected between pins M_VIN and VIN.

This current can be adjusted to a lower value by applying a dc control voltage or PWM control signal to the ADJ pin.

DC Control

The LED current can be adjusted over a 10% to 100% range by connecting a variable resistor R_{ADJ} from the ADJ pin to ground to vary the DC voltage at the ADJ pin. R_{ADJ} forms the lower part of a resistive divider and the internal 100k Ω resistor between the ADJ and V_{REF} pins forms the upper part. A value of 1M Ω for R_{ADJ} will therefore give a maximum current of 91% of $I_{LED(nom)}$ and the device will be turned off when the voltage on the ADJ pin falls below 28mV, corresponding to an R_{ADJ} value of approximately 5k Ω . If required, an end-stop resistor in series with R_{ADJ} can be used to maintain the voltage on the ADJ pin above the turn-on threshold.

Using a logarithmic potentiometer for R_{ADJ} will give an approximately linear variation of output current with shaft rotation. (Fig 1)

If required, the maximum output current can be restored to 100% by adjusting the value of the LED current monitor resistor (RM). The tolerance of the internal 100k resistor and R_{ADJ} should be taken into account when calculating output current.

The ADJ pin is clamped internally to a voltage of 575mV (nom), to limit maximum average output current to approximately 115% of $I_{LED(nom)}$.

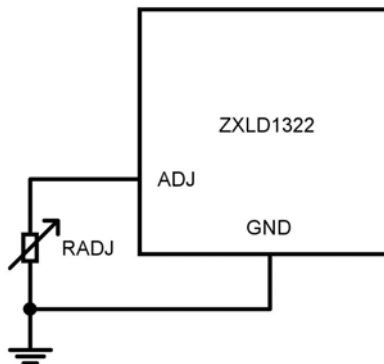

Fig. 1

PWM Control

A wider dimming range can be achieved by applying a PWM control signal to the ADJ pin to turn the device on and off, giving an average output current proportional to the duty cycle of the control signal. The ADJ pin can be driven directly from the open drain NMOS output of a microcontroller, or indirectly with a low saturation voltage NPN transistor such as the Zetex ZXTN25015DFL. (Fig 2).

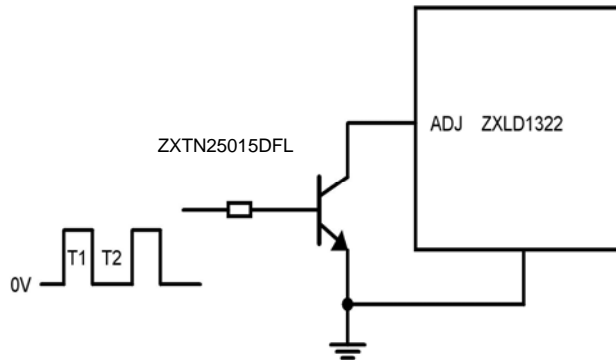

Fig. 2

In the circuit of Fig 4, the average LED output current will be:

$$I_{LED (AVG)} = I_{LED(NOM)} * D$$

Where duty cycle

A PWM frequency of 200Hz, or lower is recommended, to minimize errors due to the rise and fall times of the converter output.

Thermal Compensation of LED Current

High-luminance LEDs often need to be supplied with a temperature compensated current in order to maintain stable and reliable operation at high temperatures. This is usually achieved by reducing the LED current proportionally from its nominal set value when the LED temperature rises above a predefined threshold. (Fig.3)

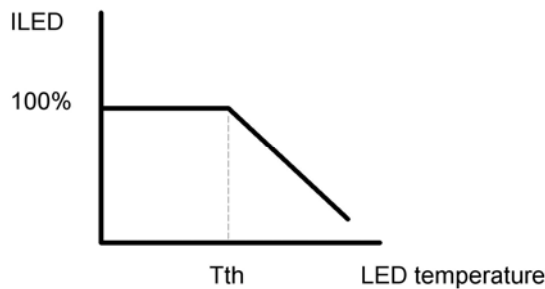

Fig. 3

The 'Thermal compensation current' generator inside the ZXLD1322 provides the necessary thermal compensation current to meet this requirement, using an NTC thermistor and resistor. (Fig 4)

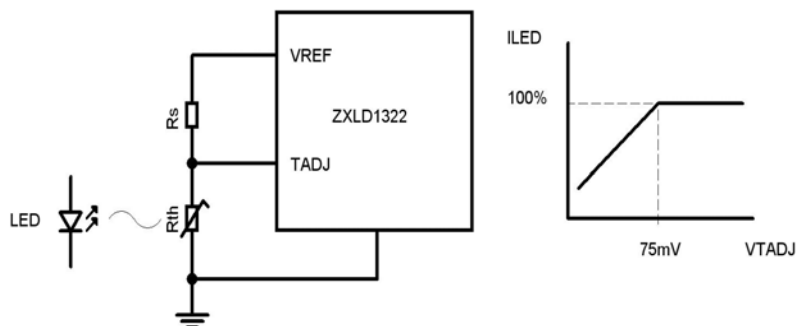

Fig. 4

ZXLD1322

The TADJ pin of the device has a voltage threshold of 75mV nominal, which is derived from the reference voltage V_{REF} . If the voltage (V_{TADJ}) on the TADJ pin is held above the threshold, the thermal compensation current will be zero and no thermal compensation is applied. However, if V_{TADJ} falls below the threshold, a thermal compensation current (ITC) is produced that is proportional to V_{TADJ} . ITC is injected into the control loop in such a way as to reduce the demand current I_{ADJ} , causing the control loop to decrease the LED current. The LED current will be reduced to less than 10% of the set value when V_{TADJ} falls below 50mV.

The threshold voltage has been chosen to set a nominal threshold of 105°C and the device has been optimized to operate with a standard 103KT1608 thermistor and 5k resistor in the potential divider. Circuit details are given in the application notes. Alternative thermistor/resistor networks can be used providing the input resistance presented to the device at the TADJ pin is similar at the threshold temperature. If no LED thermal compensation is required, the TADJ pin should be connected to V_{REF} to disable this function.

Typical Operating Conditions

Inductive converters can operate in either CONTINUOUS mode, where current always flows in the inductor, but rises during the ON period and falls during the OFF period, or DISCONTINUOUS mode, where the current falls to zero during the OFF period. The mode depends on several factors, including supply voltage, output (LED) voltage and the choice of peak current and inductor value. Calculations need to be done to determine which mode the converter will be in. The circuit should be designed to give slightly more LED current than required under the lowest supply voltage, so the control loop can regulate the current accurately. If the theoretical LED current is less than that required, the control loop will not be able to reach the required value. The calculations will give an idea of the ON and OFF times and hence the operating frequency, but bear in mind that the control loop will reduce the peak current to achieve the exact programmed LED current and this will raise the operating frequency. In general, values in the discontinuous mode are simpler to calculate because the current can go from zero to the theoretical maximum during the ON period and fall to zero during the OFF period. In continuous mode the current will start from some value, so the ON time will be lower to reach the theoretical maximum and lower still when the control loop reduces the peak current below the maximum.

Circuit Operation

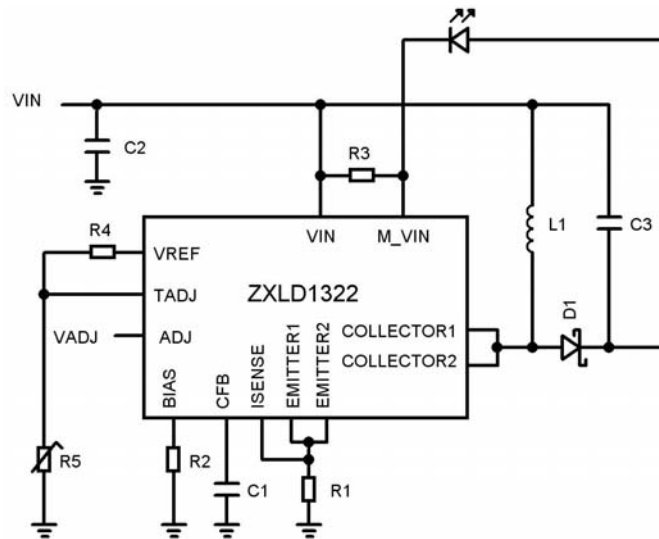

Operation of buck / boost LED driver

Used when the input voltage can go higher or lower than the LED voltage, this circuit has an ON phase, where the coil is connected from the supply to ground and an OFF phase, where the coil current flows through the LED via a Schottky diode. The current therefore only flows into the LED circuit during the OFF phase, although the reservoir capacitor C3 should keep current flowing in the LED(s) continuously. The important difference is that this circuit has the LED cathode taken to VIN instead of ground.

ADJ is set between 50mV and 500mV to give between 10% and 100% power respectively. Making R2 = ZERO gives a base current to the output transistor of 50mA nominal and making R2 = 1.68kΩ gives 10mA nominal. The reduced base current will lower supply current and hence improve efficiency in lower power applications. Making R1 = 25mΩ gives a peak coil current of 2 Amps. The internal power transistor turns on until the coil current builds up to the peak value. At this

point the transistor switches off and the coil current continues to flow in the LED(s) via the Schottky diode D1.

With a buck converter, the LED is in series with the coil, so no coil current can flow until the supply voltage exceeds the LED forward drop. The circuit will not work if the supply is less than this. With a boost converter, there is always a path from supply to ground through the coil, Schottky diode and LED in series, so if the supply voltage is greater than the LED and Schottky forward drops, unlimited current will flow in the LED. The circuit will not work if the supply is greater than this. Thus neither circuit will work for both conditions, where the supply could be either higher or lower than the LED forward drop, for example when using 3 cells to supply it.

Although it looks like a boost circuit, taking the LED cathode to the supply means that no current can flow in the LED even if the supply is greater than the forward drop. However, because the coil is still connected straight across the supply during

ZXLD1322

the ON phase, the current can still be established when the supply is less than the LED forward drop. Hence this circuit will work at supply voltages above and below the forward LED drop.

This mode is useful for example when using 3 cells and a white LED, where the voltage of 3 fully charged alkaline cells is more than the LED forward drop, but the voltage of 3 partly discharged rechargeable NiCd cells is less than the LED forward drop.

The LED current is sensed by R3 and the controller varies this until the drop in R3 equals 20% of V_{ADJ} . Hence making $R3 = 100m\Omega$ and $V_{ADJ} = 500mV$ gives a LED current of 1 Amp because the 500mV V_{ADJ} results in 100mV across R3 which equals 1 Amp. Making $V_{ADJ} = 10mV$ gives a LED current of 100mA because the 50mV V_{ADJ} results in 10mV drop across R3 which equals 100mA.

The power is controlled by the chip backing off the peak coil current, so it is necessary to calculate the coil inductance and current to guarantee slightly more than 100% LED power, so the circuit can control it effectively. The internal control loop is compensated by C1, which is normally 10nF.

If the thermistor (R5) is used, the power will be backed off progressively as the TADJ pin goes low. With the TADJ pin above 75mV, power is 100% and this is reduced to zero when the T_{ADJ} pin reaches 50mV. Making $R4 = 5k\Omega$ and using a 103KT1608 thermistor, the thermistor will reach 869 Ω at 105°C giving $V_{TADJ} = 74mV$ which will start to reduce the LED power above 105°C. By 125°C the thermistor will reach 547 Ω giving $V_{TADJ} = 50mV$ which gives zero power. This will protect the LED from damage. These temperature values can be set by the customer by using a different thermistor or a different value of R4. If protection is not required, leaving the TADJ pin open circuit will make it float to a high voltage and always give 100% power.

Bill of materials

Reference	Part No	Value	Manufacturer	Contact Details
U1	ZXLD1322	LED Driver	Zetex	www.zetex.com
D1	ZHCS2000	Schottky diode	Zetex	
L1	MSS7341-103ML	10 μ H 2A	Coilcraft	www.coilcraft.com
L1	NPIS64D100MTRF	10 μ H 2A	NIC	www.niccomp
L1	744 777910	10 μ H 2A	Würth	www.wurth.co.uk
C1	Generic	10nF 10V	Generic 0603	
C2	GRM31CR71H475K	4.7 μ F 50V	Murata 1206	www.murata.com
C3	GRM31MR71E225K	2.2 μ F 25V	Murata 1206	www.murata.com
R1	Generic	25m Ω	Generic 0805	
R2	Generic	1.5k Ω	Generic 0603	
R3	Generic	100m Ω	Generic 0805	
R4	Generic	5.1k Ω	Generic 0603	
R5	Thermistor NTC	10k	103kt1608	

Additional Notes

Note that the ON time is set by the time it takes the coil to reach the peak current. This peak value is reduced by the control loop to give the desired LED power, so the ON time can vary over a wide range. The minimum coil current can be zero (discontinuous operation) or finite (continuous operation) depending on the supply voltage, LED current and the LED voltage. The OFF time is set by an internal timer and is nominally 1.2 μ s at 100% LED power ($V_{ADJ} = 500\text{mV}$), increasing to about 8 μ s at 10% LED power ($V_{ADJ} = 50\text{mV}$). The longer OFF time and variable peak current enables the circuit to dim the LED whilst maintaining continuous switching, rather than "skipping" or stalling and continuous running is better for reducing electrical noise and also for eliminating audible noise from the coil core.

Layout Considerations

As with all switching DC to DC converters, the currents can be large. Using small inductors with a reasonable high supply voltage will cause currents to change quickly. High dI/dt can cause inductively-coupled spikes into adjacent tracks. At the transition from of the ON phase to the OFF phase and back, where the power transistor switches, the voltage at the collector rises and falls quickly. High dV/dt can cause capacitively coupled spikes into adjacent tracks, especially if they have a high impedance. For this reason, all tracks on the PCB should be thick, to minimise drops, and short to keep all the components coupled tightly together.

A double-sided board should be used with a ground plane to screen the tracks and provide a good ground return for the various functions and the rear exposed pad on the package should have an appropriately-sized land with good ground connections, both to reduce electrical noise due to ground drops and to improve thermal conductivity.

The input decoupling capacitor C1 should be very close to the chip pins and the LED sense resistor R3 should have Kelvin tracks to M_VIN and VIN to achieve LED current measurement accuracy, as the PCB tracks will have comparable resistance to the 100m Ω resistor, so taking sense tracks to the current monitor which are not connected close to the ends of R3 will cause a measurement error.

The peak current sense resistor R1 should have short tracks to the ground at the bottom end and Kelvin tracks to I_{SENSE} at the top end. This resistor might need to be only 25m Ω and PCB track resistance becomes comparable if the tracks are not very short. I_{SENSE} is a high impedance input, so a thin track from this pin directly to the top of R_{SENSE} resistor R1 will still give an accurate measurement.

The ADJ pin should have short tracks, as this is a fairly low-level signal controlling the power of the system. As it needs to be less than 28mV for shutdown, a close ground connection is needed for the pull-down device, as any ground drops could raise the potential. In particular, if a bipolar transistor is used as a pull-down device, this will have an appreciable V_{SAT} , which could perhaps be half the shutdown potential.

The bottom of the thermistor must be coupled very closely to ground, as the TADJ pin varies the LED current from 100% to 0% for a voltage change of only 25mV, so any noise on the bottom of the thermistor will seriously affect the accuracy of the Thermal Protection circuit.

Ordering Information

Device	Reel Size (mm)	Reel Width (mm)	Quantity per reel	Device Mark
ZXLD1322DCCTC	33.02	12	3000	1322

Package Outline – DFN4030-14

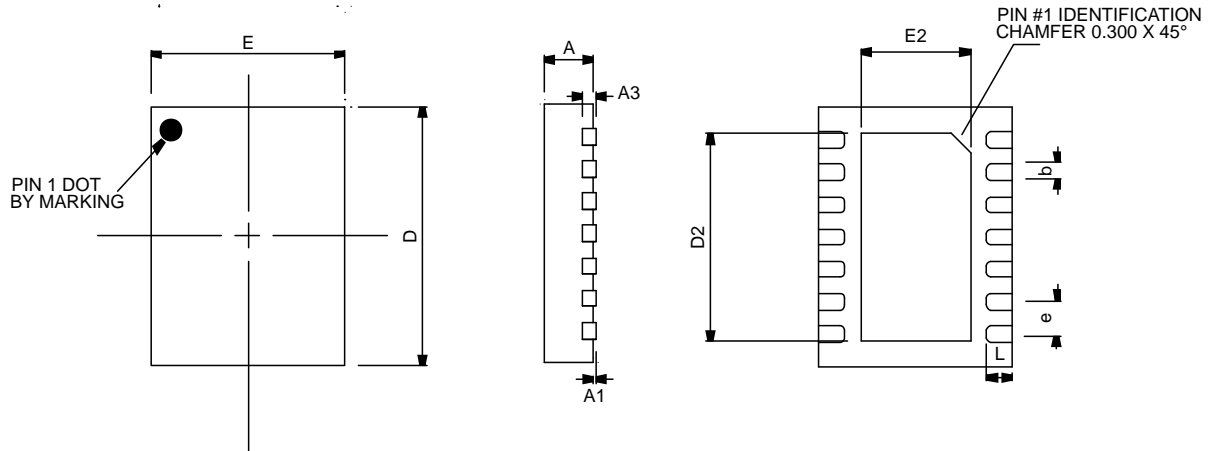

DIM	Inches		Millimeters		DIM	Inches		Millimeters	
	Min	Max	Min	Max		Min	Max	Min	Max
A	0.0315	0.0354	0.80	0.90	D2	0.1240	0.1279	3.15	3.25
A1	0.00	0.002	0.00	0.05	e	0.0197 BSC		0.50 BSC	
A3	0.008 REF.		0.203 REF.		E	0.1161	0.1201	2.95	3.05
b	0.0079	0.0118	0.20	0.30	E2	0.0650	0.0689	1.65	1.75
D	0.1555	0.1594	3.95	4.05	L	0.0138	0.0177	0.35	0.45

Note: Controlling dimensions are in millimeters. Approximate dimensions are provided in inches

IMPORTANT NOTICE

DIODES INCORPORATED MAKES NO WARRANTY OF ANY KIND, EXPRESS OR IMPLIED, WITH REGARDS TO THIS DOCUMENT, INCLUDING, BUT NOT LIMITED TO, THE IMPLIED WARRANTIES OF MERCHANTABILITY AND FITNESS FOR A PARTICULAR PURPOSE (AND THEIR EQUIVALENTS UNDER THE LAWS OF ANY JURISDICTION).

Diodes Incorporated and its subsidiaries reserve the right to make modifications, enhancements, improvements, corrections or other changes without further notice to this document and any product described herein. Diodes Incorporated does not assume any liability arising out of the application or use of this document or any product described herein; neither does Diodes Incorporated convey any license under its patent or trademark rights, nor the rights of others. Any Customer or user of this document or products described herein in such applications shall assume all risks of such use and will agree to hold Diodes Incorporated and all the companies whose products are represented on Diodes Incorporated website, harmless against all damages.

Diodes Incorporated does not warrant or accept any liability whatsoever in respect of any products purchased through unauthorized sales channel.

Should Customers purchase or use Diodes Incorporated products for any unintended or unauthorized application, Customers shall indemnify and hold Diodes Incorporated and its representatives harmless against all claims, damages, expenses, and attorney fees arising out of, directly or indirectly, any claim of personal injury or death associated with such unintended or unauthorized application.

Products described herein may be covered by one or more United States, international or foreign patents pending. Product names and markings noted herein may also be covered by one or more United States, international or foreign trademarks.

LIFE SUPPORT

Diodes Incorporated products are specifically not authorized for use as critical components in life support devices or systems without the express written approval of the Chief Executive Officer of Diodes Incorporated. As used herein:

A. Life support devices or systems are devices or systems which:

1. are intended to implant into the body, or
2. support or sustain life and whose failure to perform when properly used in accordance with instructions for use provided in the labeling can be reasonably expected to result in significant injury to the user.

B. A critical component is any component in a life support device or system whose failure to perform can be reasonably expected to cause the failure of the life support device or to affect its safety or effectiveness.

Customers represent that they have all necessary expertise in the safety and regulatory ramifications of their life support devices or systems, and acknowledge and agree that they are solely responsible for all legal, regulatory and safety-related requirements concerning their products and any use of Diodes Incorporated products in such safety-critical, life support devices or systems, notwithstanding any devices- or systems-related information or support that may be provided by Diodes Incorporated. Further, Customers must fully indemnify Diodes Incorporated and its representatives against any damages arising out of the use of Diodes Incorporated products in such safety-critical, life support devices or systems.

Copyright © 2010, Diodes Incorporated

www.diodes.com

Looking for pricing, stock, or lifecycle information?

Click below to explore more details on WIN SOURCE:

 [View ZXLD1322DCCTC on WIN SOURCE](#)

 [Diodes Incorporated Information](#)

Optimize Your Supply Chain with WIN SOURCE Solutions

-  Global Sourcing Solution
-  Obsolete Management
-  Cost Control Management
-  Shortage Management
-  Alternative Solution
-  Excess Inventory Management